



Are energy policies for supporting low-carbon power generation killing energy storage?

Chun Sing Lai ^{a, b}, Giorgio Locatelli ^{a, *}

^a School of Civil Engineering, Faculty of Engineering and Physical Sciences, University of Leeds, Leeds, LS2 9JT, UK

^b Brunel Institute of Power Systems, Department of Electronic & Electrical Engineering, Brunel University London, London, UB8 3PH, UK



ARTICLE INFO

Article history:

Received 31 May 2020

Received in revised form

6 September 2020

Accepted 7 October 2020

Available online 16 October 2020

Handling editor: Zhifu Mi

Keywords:

Energy storage

Low-carbon power incentives

Contract for difference

Generation integrated energy storage

ABSTRACT

This paper explores the impacts of energy policies for supporting low-carbon infrastructure on the economic and financial performance of energy storage when coupled with a generator. The study sets in the UK context and the unit of analysis is the generator connected with energy storage. An analytical method is derived to assess the impact of policy schemes for low-carbon infrastructure on energy storage. The case study of energy storage systems coupled with a Small Modular nuclear Reactor (SMR) is quantitatively investigated in three scenarios: 1. SMR-only (the baseline); 2. SMR with thermal energy storage; and 3. SMR with Lithium-ion battery. For the strike price at 100 £/MWh, the net present value for scenarios 2 and 3 reduces from 562 M£ to 379 M£ and from 376 M£ to -1144 M£, respectively, when the energy storage capacity increases from 100 MWh to 1 GWh. As the net present value reduces with increased energy storage capacity (when coupled with generation), this work shows that low-carbon incentives are, unintentionally, barriers to the development of energy storage due to: (A) current generator incentives give a favourable return on investment and energy storage would diminish it; (B) energy storage cannot participate in generator only incentives.

© 2020 The Authors. Published by Elsevier Ltd. This is an open access article under the CC BY license (<http://creativecommons.org/licenses/by/4.0/>).

1. Introduction

Renewable (Lai et al., 2017) and nuclear (Locatelli et al., 2018) technologies are capital intensive with marginal costs being close to zero. As a low-carbon infrastructure, these technologies have received and receive support from several governments according to their energy policies. For instance, in the UK, these policies included the Non-Fossil Fuel Obligation/Scottish Renewable Obligation, feed-in tariff, and Renewable Obligation. Today, the UK energy policy for low-carbon electricity, consisting of Contract for Difference (CfD) and Capacity Market (CM) (Electricity Market Reform (EMR), 2017). In Germany, low-carbon electricity is supported by feed-in tariffs and low interest loans (About RES LEGAL Europe). Similar incentives are in place across the world including the EU, USA, and Asia (Barkatullah and Ahmad, 2017).

Generally, renewable energy systems have limited controllability of the output power. Solar power output is directly proportional to the solar irradiance, and it is affected by atmospheric

conditions and the diurnal cycle (Lai, 2019). Wind power is a function of wind speed, density of air, and rotor swept area (Wang et al., 2018). Nuclear reactors and hydropower plants can be used for load-following, but the generation cost is substantially fixed (Locatelli et al., 2018). As such, with the increment of low-carbon generation over time, energy storage is relevant to ensure grid flexibility by providing power generation-demand balance (Cebulla et al., 2018). Energy storage can act as a load and store the surplus electricity (i.e., generation is greater than demand) or meet the energy deficit by acting as a generator and discharge electricity (Li et al., 2020).

There are several types of energy storage ranging from electrical, electrochemical, mechanical, and hydro (Amirante et al., 2017). In particular, there are two classes of systems when considering energy generation and energy storage, namely Generation Integrated Energy Storage system (GIES) and non-GIES. GIES stores energy at some point, along with the transformation between the primary energy form and electrical energy (Garvey et al., 2015a). An example of GIES is the concentrated solar power with thermal energy storage, as heat is the primary energy form and also the energy for storage. Non-GIES directly converts the primary energy into electricity for storage, such as a permanent magnet synchronous

* Corresponding author.

E-mail addresses: chunsing.lai@brunel.ac.uk (C.S. Lai), g.locatelli@leeds.ac.uk (G. Locatelli).

generator for wind energy with electrochemical energy storage (Xia et al., 2018). Pumped-hydro energy storage is the most common technology for storing MWh, while compressed air energy storage is emerging (Ghorbani et al., 2020). In the past five years, there has been an upsurge in building MWh scale energy storage with batteries due to the increase of renewable penetration, reduced cost and technological maturity of batteries (e.g., Lithium-ion) (Lai et al., 2017). In the future, GIES should be increasingly deployed for storing several MW of capacity. However, the majority of low-carbon infrastructure investments has been focused on generation but not in energy storage technologies, e.g., European countries in 2018 have invested 57.6 B€ in low-carbon energy with over 80% of the investment in wind (onshore and offshore) and solar technologies (Clean energy investment trends, 2018). These renewable technologies need energy storage, but investments in energy storage are an order of magnitude lower. This work aims to present, discuss, and quantify the unintended effect of policies designed for low-carbon infrastructures on energy storage in particular for GIES. Without loss of generality, the paper adopts the UK as context and will detail analytically and numerically a case study of a nuclear reactor coupled with energy storage.

This paper aims to:

1. Clarify the mechanisms supporting the low-carbon power generation and energy storage in the UK by describing their similarities and differences;
2. Investigate to what extent these mechanisms supporting low-carbon power generation become unintended barriers for the deployment of energy storage systems. This analysis is twofold:
 - 2a) analytically to show the theoretical limits of supporting mechanism;
 - 2b) numerically to quantify the impact in case of Small Modular nuclear Reactors (SMRs) coupled with GIES and non-GIES.

The rest of the paper is organised as follows. Section 2 presents a review on the drivers of growth for energy storage by identifying the energy storage installation growth globally and in the UK and European countries. Section 3 reviews the policy mechanisms in the UK for low-carbon energy generation and storage. To examine the financial effect on the energy storage technologies with the presence of low-carbon CfD, Section 4 analytically and numerically investigates the unintended effects of incentives for low-carbon generation when coupled with energy storage. Section 5 concludes the paper and provides policy recommendations for energy storage.

2. Energy storage installation and policies

This section firstly presents a review of the energy storage installation growth in the world. Next, the UK context is assumed and the forecasted energy storage installation growth in the UK is provided. The drivers for energy storage growth are given in the UK; these are: 1) rapid installation of non-dispatchable energy sources, 2) revenue sources, mechanisms, and policies for energy storage.

2.1. Global energy storage capacity installation

Fig. 1 shows the global energy storage installed capacity considering grid-scale (i.e., front-of-the-meter) and behind-the-meter sectors. Energy storage deployment achieved a record level in 2018 at 8 GWh (nearly doubling from that in 2017), and behind-the-meter storage (i.e., not grid installation) trebled from 2017 to 2018 (Energy Storage; Tracking clean energy progress). Behind-the-meter storage growth matches grid-scale storage growth. The

leading countries are Korea, China, USA, and Germany (Energy storage: Tracking clean energy progress). Lithium-ion battery continued to be the most popular installed electrochemical energy storage (after pumped-hydro energy storage) accounting for 85% of all new capacity installed. China became the market leader of energy storage installation in 2018, due to grid companies supported using energy storage for network operations and the introduction of markets for frequency regulation services (Energy storage: Tracking clean energy progress).

A relevant case for energy storage is microgrids. Microgrids are low voltage distribution networks with different distributed generators, storage systems and controllable loads that can operate interconnected or isolated from the main distribution grid as a controlled entity (Hatzigiorgiou et al., 2005). For instance, delivering natural gas to power plants in Iran is challenging, which drives the need for microgrids (Safdarian et al., 2014). Hence, Safdarian et al. (2014) presented an optimisation model for microgrid's, built for a factory, day-ahead operation planning. The microgrid consists of a gas turbine, PV, fuel cell, hydrogen storage tank, electrolyser, reformer, boiler, and thermal and electrical loads. The model maximises the profit and satisfies economic and technical constraints whilst avoiding load shedding. The authors concluded that installing microgrids in the USA would be more economical than Iran, considering the energy prices in 2014 and without the fuel subsidies in Iran from 2011.

Germany and the UK led the energy storage installation growth in Europe. Germany and France together committed 1.7 B€ to support local manufacturing in batteries (Energy storage: Tracking clean energy progress). Co-location of renewable energy production systems and energy storage is becoming increasingly popular in Europe and the USA (Energy storage: Tracking clean energy progress). This is largely driven by increasing the value of electricity produced by providing additional flexibility.

2.2. Energy storage and low-carbon power generation installation growth in the UK

In 2020, there was continued development and growth in energy storage with 164 MW of new energy storage capacity (mostly batteries). Most energy storage systems are connected to the distribution network (Future energy scenarios, 2020a). Other types of energy storage include non-electrochemical technologies such as liquid air energy storage (i.e., inexpensive electricity cools air to a liquid state and is later heated and pumped to run a turbine). 80% of these projects are being installed on the distribution network and possibly alongside generators (Future energy scenarios, 2020b). Most co-located projects are with solar and wind generation, but also include co-located hydro, tidal or gas generation.

Fig. 2 shows the projected energy storage installation growth for four scenarios. Energy storage projects will need multiple income streams to be commercially viable for all scenarios, including price arbitrage and grid services (described in Section 4), where the energy storage owner is paid for delivering energy to the grid at challenging times including energy imbalance events (Fast reserve; Short Term Operating Reserve (STOR)).

The National Grid study may not have taken the policy implications into account (such as CfD). Also, new electricity tariffs and business models in the energy storage market are expected to be developed, which affect energy storage growth. The energy storage installation increases for "Community Renewables" and "Two Degrees" due to the grid's flexibility needs caused by low-carbon power generation. The installation growth is less significant for the other two scenarios. The growth is steeper from the 2030s for "Community Renewables" as both renewable generation (i.e., wind and solar) and demand increases. Different to "Two Degrees",

Grid-scale and behind-the-meter energy storage in operation

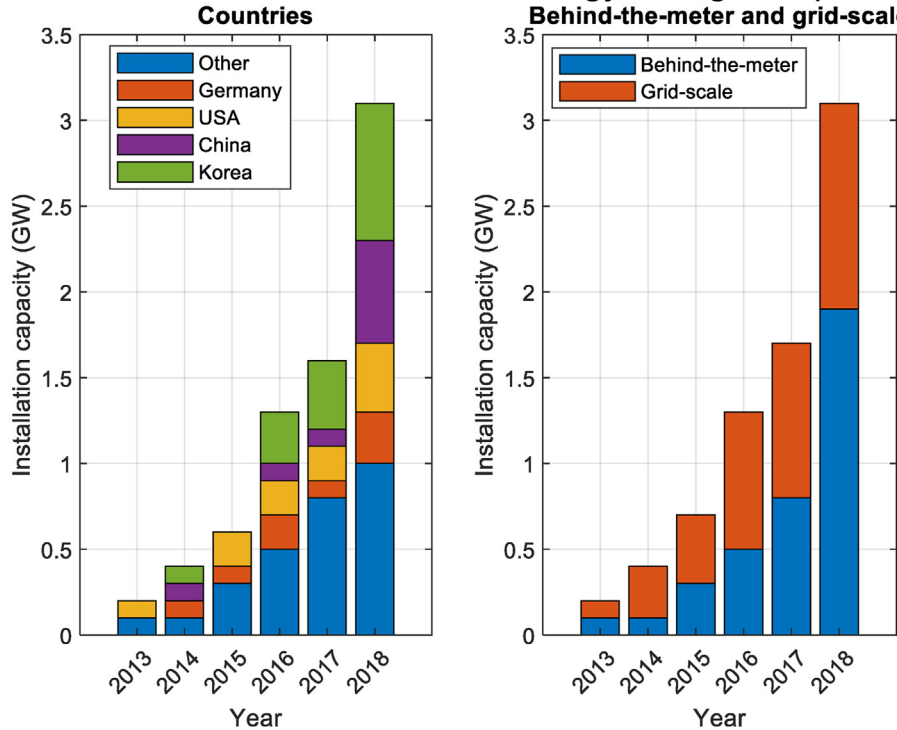

Fig. 1. Global grid-scale and behind-the-meter energy storage deployment in different countries (Energy storage: Tracking clean energy progress).

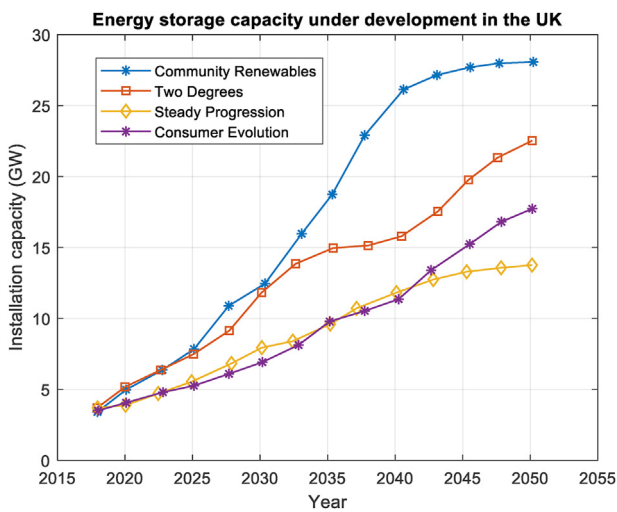

Fig. 2. National Grid’s future energy storage installation forecast (Future energy scenarios, 2020b).

“Community Renewables” assumes that there are fewer grid interconnections and more small-scale generation energy storage co-located systems.

For the “Community Renewables” scenario, the country achieves the 2050 decarbonisation target in a decentralised energy landscape (Future energy scenarios, 2020b). Local energy schemes would flourish, consumers are committed and enhancing energy efficiency is the top agenda. Most homes and businesses will adopt electric heat. Consumers would incline for electric transport, and simple digital solutions to assist them effortlessly to manage their energy demand. Policies will be developed to promote onshore

wind generation and energy storage technology development. Novel schemes will be developed to provide a platform for other green energy innovation to satisfy local needs. In summary, “Community Renewables” foresees an emission reduction target from 503 MTeCO₂ (year 2017) to 165 MTeCO₂ (year 2050).

For the “Two Degrees” scenario, the country achieves the 2050 decarbonisation target with large-scale centralised solutions (Future energy scenarios, 2020b). Large-scale solutions (e.g., energy storage) would be available, and consumers are assisted in picking alternative heat and transport options to achieve the 2050 target. Homes and businesses would adopt hydrogen and electric technologies for heat. Consumers prefer electric vehicles and hydrogen is widely adopted for commercial transport. Growing renewable capacity, enhancing energy efficiency and accelerating new technologies, including carbon capture, usage, and storage are policy priorities. The emission reduction target is the same as that of “Community Renewables” scenario.

The UK has been advocated on low-carbon energy provision to tackle climate change. Internationally, the UK participates The Paris Agreement within the United Nations Framework Convention on Climate Change (Bataille et al., 2018). The EU commitments influence the UK’s low-carbon power generation and carbon reduction energy policy. There are two key Acts of Parliament related to climate change:

- **Climate Change and Sustainable Energy Act, 2006** (Climate Change and Sustainable Energy Act, 2006): Aims to boost the number of heat and electricity micro-generation installations. The act aims to reduce carbon emissions and fuel poverty
- **Climate Change Act, 2008** (Climate Change Act, 2008): The Secretary of State is tasked to ensure that the net UK emission account for all six Kyoto greenhouse gases by 2050 is at least 80% lower than the 1990 baseline. This act made the UK the first

country to establish a long-term, legally binding framework to cut carbon emissions

Fig. 3 presents the UK energy shares of renewable, nuclear, and fossil fuel generation (Roberts and Clark; "Historical electricity d, 1920). To the best of the authors' knowledge, there is no comparable figure for current energy storage in the UK. Since the 2010s, renewables rapidly grow due to the plummeting cost and technological maturity. At the same time, the Government provides incentives such as feed-in tariff for small-scale (under 5 MW capacity) renewable generation. Therefore, renewables have become another important form of electricity generation (Swanson, 2006).

As of 2019, eight nuclear power stations were in operation which supplied 18.7% of the total electricity supply in 2018 (Roberts and Clark). Eleven nuclear plants (above 200 MW) have retired (Country nuclear power profiles, 2018). Nuclear installed capacity peaked at 12.7 GW in 1995 with Sizewell B beginning operation (the final nuclear reactor to commence servicing). The UK has a robust plan for revamping its nuclear capacity. As of 2020, there are 3.2 GWe of nuclear power under construction and a further 7.8 GWe is proposed in already identified sites, plus a strong interest toward Small Modular Reactors.

As of 2019, 69% of renewable generation was from weather-dependent energy sources, mostly wind and solar (Waters and Spry, 2020). The major renewable sources are wind (onshore and offshore), solar photovoltaic and concentrated solar power, hydro, wave, tidal, landfill gas, plant biomass, and anaerobic digestion (Digest of UK Energy Statistics (DUKES)). Energy storage is needed to overcome the intermittency. On Aug. 9, 2019 at 4:52 p.m., one million British people suffered a loss of electricity from a blackout (Interim report into the low frequency, 2019). It was one of the worst blackouts over a decade affecting commuters on a Friday

rush hour. Wind and gas generators provided most of the electricity (30% each) shortly before the blackout. After lightning strikes on the transmission circuit, the Hornsea offshore windfarm and Little Barford gas power station both reduced the electricity supply to the grid. All "reserve power" (including 472 MW of battery storage) were used with the hope to balance the power supply. However, the scale of generation loss was too big, so loads have to be disconnected to recover the grid's frequency.

Distribution energy storage supplying energy to the local load demand will reduce the need for transmitting electricity via long-distance transmission lines. Effectively, energy storage provides backup power to local loads and better utilise intermittent generation energy to enhance system resilience for distribution systems (Kim and Dvorkin, 2018). Generally, power system resilience characterises the system's ability to resist, adapt to, and timely recover from disruptions.

In summary, this section has shown that there is an increasing installation of energy storage worldwide, largely driven by higher penetrations of renewables (the similar reason for other countries). However, even if the energy storage installation growth (Section 2.1) has been seen promising, in general, energy storage capacity installed is still a very small fraction as compared to that produced by low-carbon power generators (e.g., in 2018, 280 TWh of low-carbon electricity was produced in the UK alone). The next section presents the key drivers for energy storage growth in the UK in particular how technologies can help the country to achieve the net-zero emissions target by 2050.

2.3. Energy storage and UK's 2050 net-zero emissions target

The Carbon Trust and Imperial College London (An analysis of electricity system, 2016) reported that the UK could save 17–40 B£ across the electricity system from 2016 to 2050, by

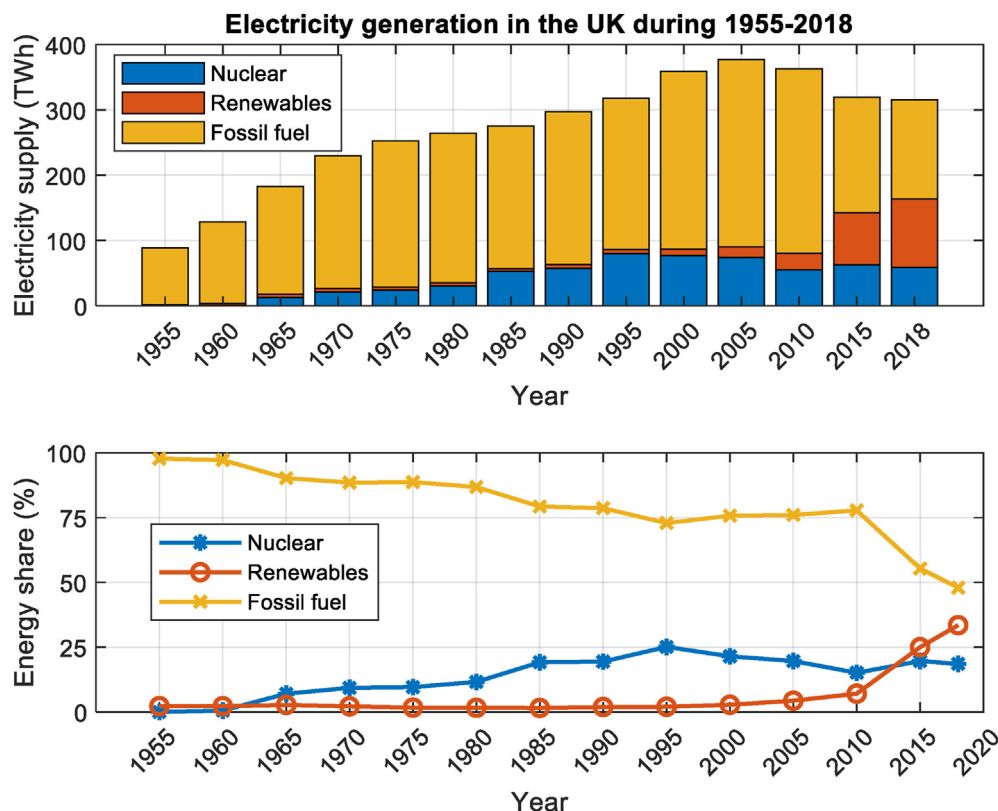

Fig. 3. Electricity supply with nuclear, renewables and fossil fuel in the UK from 1955 to 2018 (Roberts and Clark; "Historical electricity d, 1920).

adopting flexibility technologies when compared against electricity systems that do not adopt extra flexibility technologies. The report identified demand-side response, energy storage and inter-connectors as the three key technologies to provide flexibility. The “balanced” deployment of the three technologies is the “least worst regret” pathway for the energy system. Regret is defined as the mix of technologies for balancing the electricity system and satisfying the electricity requirements that is more expensive than the cheapest option which could have been adopted. A balanced deployment strategy mitigates maximum regret scenarios which can occur during one technology is preferred, and it happened to be the wrong option. The minimum regret in the balanced deployment is approximately zero and occurs when demand-side response cost, energy storage cost and energy demand are all high.

In 2019, the National Grid ([Future energy scenarios, 2020b](#)) had reported the use of energy storage for different markets to work together to meet the 2050 carbon reduction target. Siemens had constructed an energy storage demonstration system to learn the feasibility of utilising ammonia in the energy supply chain through a low-carbon production process. The demonstration system employed a wind-powered electrolyser to produce hydrogen. Ammonia was synthesised with the Haber-Bosch process and stored for conversion back to electricity when needed. Electrolysers can work as energy storage and powered by renewable electricity. Electrolysers under 1 MW are operating globally for transport fuelling. The challenge is to demonstrate that mass electrolysis production can be economically competitive. National Grid has mentioned that projects are underway to prove the commercial and technical viability of units up to 250 MW ([Future energy scenarios, 2020b](#)).

In 2017, the UK government and Ofgem drafted the “smart systems and flexibility plan” ([Upgrading our energy system, 2017](#)) to examine the process to 1) remove barriers to smart technologies including storage; 2) enable smart homes and businesses; 3) make markets work for flexibility. The Government acknowledged that energy storage faces several specific regulatory and policy barriers which put the technology at a disadvantage compared to other forms of flexibility. Targeted Charging Review identified that storage facilities should not pay the ‘demand residual’ element of network charges at the transmission and distribution level. Storage providers should only pay one set of balancing system charges. Ofgem indicated that these changes to storage charging would best be brought forward by industry, and two modifications have now been raised to address these issues.

For energy storage (excluding pumped hydro), the Department for Business, Energy & Industrial Strategy ([Consultation outcome, 2019](#)) in July 2020 legislated to remove the technology from the Nationally Significant Infrastructure Projects regime in England and Wales. The primary consenting route for electricity storage in England is under the Town and Country Planning Act 1990. In Wales, planning decisions for electricity storage are normally consented by the applicable Local Planning Authority under the Town and Country Planning Act regime. Currently, this is only the case for electricity storage below 350 MW. These changes simplify large-scale storage facilities to seek planning permission.

In summary, energy storage systems are critical assets for the UK to achieve the net-zero emissions goal in 2050. Recently, the Government has created legislation to promote energy storage. However, additional efforts are required to make energy storage economic and attractive to stakeholders.

2.4. Revenue sources for energy storage in the UK

Historically in the UK, there were no policy and incentive schemes specific for energy storage. For instance, energy storage

was not defined within the legislation for the Renewable Obligation or feed-in tariff scheme. As of today, grid energy storage can receive revenues from the following sources:

Electricity markets: *Spot price/wholesale market:* Electricity is a commodity that can be traded in the wholesale market from various energy technologies. The wholesale price increases with electricity demand. Nord Pool AS is a European power exchange and is responsible for delivering power trading across Europe ([N2EX day ahead auction prices](#)).

National Grid (grid services):

- *Firm Frequency Response (FFR):* FFR complements other categories of frequency response (e.g., primary response) and provides firm availability. The service can be either dynamic (i.e., continuously provided service for managing the usual second-by-second system changes) or static (i.e., usually a discrete service triggered at a set frequency deviation). The minimum power capacity to provide the FFR service is 1 MW ([Firm Frequency Response FFR](#)). FFR can be from generators, energy storage, and aggregated demand response
- *Short Term Operating Reserve (STOR):* The provider gives a contracted level of power when called by National Grid to achieve energy reserve requirement (Short Term Operating Reserve (STOR)). The STOR provider must provide a minimum of 3 MW of steady demand reduction or generation for 2 h minimum. STOR technology requirement is the same as FFR
- *Fast Reserve (FR):* FR provides rapid active power by reducing the demand or increasing the generation, as requested by the National Grid Electricity System Operator ([Fast reserve](#)), to participate in controlling frequency variations. FR needs all units to be able to begin service delivery within 2 min following order, at a rate of 25 MW/min or more and deliver a minimum of 3 MW. The FR provider needs to give power consistently for a minimum of 15 min ([Fast reserve](#)). FR technology requirement is the same as FFR

Distribution network operators: *Super Red Credits (SRCs):* Distribution network operators provide SRC payments to non-intermittent generators for providing energy during peak demand times (i.e., super red periods). These generators allow the distribution network to defer the reinforcement or grid upgrade. To receive these credits, generators must be connected to the extra high voltage grid. Participation in SRC payments is possible for renewable sources with battery ([Distribution Connection, 2012](#)).

Electricity Market Reform: *Capacity Market:* As discussed in Section 3.2, energy storage cannot participate in CfD. Some energy storage (e.g., battery) can be placed far from generators, while other energy storage (e.g., hydro) are necessarily co-located with the generators. Remarkably, the co-location is either explicitly provided for or strictly prohibited under the UK.

2.5. Factors influencing energy storage installation in a global context

Gissey et al. ([Castagneto Gissey et al., 2018](#)) categorised the 16 investment barriers for delaying the energy storage deployment in electricity markets. One of the barriers is the lack of policy or regulatory regime concerned with the energy storage in electricity system developments. Generally, the revenue sources that affect energy storage deployment concerning energy policies are as follows:

Financing: Financing plays a crucial role in the successful delivery of the energy storage system by effectively allocate assets and liabilities over time. [Saviuc et al. \(2019\)](#) examined a support scheme (via contributing to paying the system cost) in which a third party

(e.g., local Government) provides the financing in return for the ownership of the battery. For energy storage operations, the economic feasibility of residential (behind-the-meter) energy storage is supported by the “electricity charge discount program”, an energy policy scheme in South Korea since 2015 (Jo et al., 2019). The energy storage owners are paid by the governmental scheme based on the energy storage contribution to the system operator, from increasing power system flexibility, improving load management capability and reducing peak demand. Jo et al. (2019) calculated the economic impact of behind-the-meter energy storage with the discount program and is one of the earliest work on the residential energy storage economic analysis with consideration of energy policy.

Grid service remuneration: The grid operator can work with the Government to develop incentives to promote energy storage growth and strengthen the grid’s performance. Energy storage investment is uncertain due to the current regulatory requirements and electricity market. There is a lack of economic incentives to support network operators to maintain the network’s efficient operation with energy storage (Anuta et al., 2014). The power quality benefits are difficult to be quantified, and subsequently, there is no incentive given to energy storage owners for power quality improvement. To increase the energy storage installation, policy options should provide remuneration for the multiple services performed by energy storage across the energy system (Landry and Gagnon, 2015). Forrester et al. (2017) affirmed that energy policy and market conditions are key barriers for energy storage to participate in multiple grid services. Using energy storage as a traditional asset (i.e., the ability to provide one service) limits investment profitability.

Novel business model: Winfield (Winfield et al., 2018) used qualitative analysis to examine the policy frameworks development for energy storage technologies, considering technological, social, institutional and regulatory regimes in electricity systems for the EU, USA, and Canada. The conventional utility business models tend not to consider energy storage, and there is a growing interest in the private capital in energy storage development. Energy storage enables the increase of behind-the-meter activity, which may disrupt conventional utility and generation models, that typically work in the front-of-the-meter (e.g., frequency regulation and capacity payment). The role of energy storage is dependent on the configuration of the low-carbon energy system.

Electricity tariffs: By charging and discharging energy, energy storage can participate in electricity pricing schemes to increase revenues. The two most common electricity tariffs are time-of-use tariff and step (tiered) tariff (Oliva H et al., 2019). The electricity price for time-of-use tariff depends on the time of day. The time-of-use tariff is particularly effective to encourage electricity users to shift loads and relieve the grid burden. The electricity price for step tariff depends on the amount of use. Step tariff is useful to encourage energy conservation. Energy-efficient products can reduce the energy system’s revenue due to less photovoltaic energy is consumed locally (Oliva H et al., 2019). However, adding a battery to the photovoltaic system generally increases the energy system’s revenue (Oliva H et al., 2019). Oliba et al. (Oliva H et al., 2019) claimed that batteries might improve the system revenue under the flat tariff, but the revenue does not adequately compensate for its cost. There is additional revenue when the battery reduces the grid peak demand and the grid costs. With case studies for the photovoltaic and battery system in Italy, Greece, Finland, and Denmark, the findings show that electricity price affects the project bankability (Saviuc et al., 2019). The support level can be reduced by high solar resource availability and high electricity price.

3. Energy policies for low-carbon energy

In the UK, approximately 100 B£ will be spent on the electricity infrastructure within the next decade, from the start of the government energy policy called Electricity Market Reform (i.e. 2013); to meet the increasing energy demand and to replace old power stations (Electricity Market Reform (EMR), 2017). As of today, low-carbon electricity is incentivised by the Electricity Market Reform (Electricity Market Reform (EMR), 2017), which has introduced two key mechanisms (both in operation since 2014):

- Contract for Difference (CfD): To provide long-term revenue stabilisation for new low-carbon initiatives
- Capacity Market (CM): To ensure the security of electricity supply at the least cost to the consumer

3.1. Contract for Difference

CfD is a private law contract between the Low-carbon Contracts Company (company owned by Business Energy and Industrial Strategy) and a low-carbon electricity generator company (e.g., a utility owning a wind farm) (The CFD scheme). The purpose is to provide electricity generators with higher revenue stability and certainty, by minimising the exposure to changing wholesale prices and avoiding consumers from paying for higher support costs when electricity prices are high (The CFD scheme; Kozlov, 2014). Within the CfD scheme, there are three partners (Policy paper Contracts for Difference, 2019):

- **Low-carbon Contracts Company:** Issuing the contracts, managing them in construction and delivery phase, and providing CfD payments
- **National Grid:** The Delivery Body for executing the CfD allocation process
- **Office of Gas and Electricity Markets:** The government regulator for the electricity and downstream natural gas markets in the UK

The CfD budget is divided into three technology pots known as “established technologies”, “less established technologies”, and “biomass conversion” (Budget notice for CFD, 2014). The “established technologies” are energy from waste with combined heat and power, onshore wind (>5 MW), hydro (>5 MW and <50 MW), photovoltaic (>5 MW), sewage gas, and landfill gas. The “less established technologies” are advanced conversion technologies, anaerobic digestion, tidal stream, offshore wind, wave, geothermal, and dedicated biomass with combined heat and power. The developer for nuclear and immature technologies (e.g., large tidal) needs to directly negotiate with the Government on the strike price as they are not part of the technology pots (Contracts for Difference, 2015).

National Grid determines if a project qualifies to participate in CfD, and manages the valuation and allocation process. In valuation, National Grid will compare the total financial value of all qualifying projects for the delivery year with the constrained budgets for each pot and any other limits (e.g. budget notice). Valuation of each application is carried out using the valuation formula set out in the CfD Allocation Framework (Contracts for Difference, 2017a).

CfD operates as follows: Let the “current strike price” denote as the guaranteed price the generator company receives from selling its electricity, and the “current reference price” denotes as the current electricity wholesale price. The generator company receives the difference between the current strike price and the current reference price from Low-carbon Contracts Company if the current

reference price is lower than the current strike price. The generator company pays Low-carbon Contracts Company when the opposite phenomenon occurs. The operation of the CfD scheme is presented in Fig. 4.

The strike price is an important concept in CfD. There are three types of strike price defined as follows:

- The administrative strike price: Also known as the reserve price, this is the maximum support that the Government is willing to offer (Contracts for Difference, 2018). The administrative strike price for the technology is identified from the supply curve driven by the electricity generation cost. The supply curve represents the predicted amount of power capacity that could be built at various strike prices, ranked from the cheapest to most expensive (Contracts for Difference, 2018). The administrative strike price has the following three features (Contracts for Difference, 2018): 1. depending on credible cost information, 2. encouraging investors to participate in the allocation round, and 3—non-bias across technologies. In allocation, if the pot budget is within a limit, then each qualifying project will be offered a CfD contract at the administrative strike price for its technology and known as unconstrained allocation. However, if the budget exceeds, then National Grid will run an auction, also known as competitive allocation process to split the available budget between the most competitive projects
- The initial strike price: It is based on 2012 prices under the CfD contract (Contracts for Difference, 2020)
- The Current Strike Price (CSP): This is also referred to as the initial strike price with indexation adjustment (Strike price adjustment guidance, 2018; Download current and historical). The adjustment reflects the balancing system charges, transmission losses charges and inflation (outside of the generators' control). The CSP, P_C (£/MWh), is calculated from the initial strike price as follows (Strike price adjustment guidance, 2018):

$$P_C = (P_{\text{Initial}} + A_{\text{Initial}}(t)) * I(t) \tag{1}$$

P_{Initial} (£/MWh) is the initial strike price, A_{Initial} (£/MWh) is the sum of the strike price adjustments for settlement unit t in base year terms, and I is the inflation factor. The settlement unit is different for technologies, such as baseload technologies (e.g., nuclear) are 30 min and 1 h for intermittent technologies (Contracts for Difference, 2020).

Fig. 5 presents the initial strike prices and CSPs (narrow boxplot) for low-carbon technologies obtained from the Low-carbon Contracts Company's CfD registered on May 1, 2019. The crosses and circles represent the outliers for the CSP and initial strike price, respectively for onshore wind. As the offshore wind is a less established technology, there is a higher variance in the strike price. The only nuclear power plant with CfD is the Hinkley Point C. **Energy storage cannot participate in CfD.**

3.2. Capacity Market

CM aims to create enough reliable capacity (both supply and demand-side) for secure electricity supplies, in particular during critical periods for the system (e.g., poor weather conditions) (G17 - Capacity provider payments, 2018). CM allows the market to determine a price for competitive capacity. Capacity agreements are given to providers of current and new capacity, from one year (T-1) to four years (T-4) ahead. This gives investors certainty and confidence about future revenues under intermittent generation and uncertain market conditions.

The CM provides revenue in monthly capacity payments. Capacity payments are paid monthly during the delivery years to capacity providers and are calculated as follows (G17 - Capacity provider payments, 2018):

$$\text{Clearing price} \left(\frac{\pounds}{\text{MW}} \right) * \text{capacity obligation (MW)} * \text{monthly weighting average (\%)} \tag{2}$$

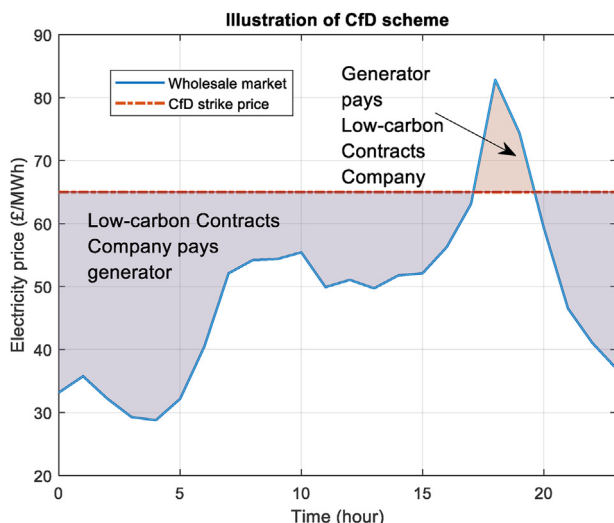

Fig. 4. The payments in the CfD scheme under wholesale market price and strike price.

Fig. 6 shows the clearing prices in the T-4 capacity auction. For 2022/23 delivery, the postponed T-4 auction originally scheduled in Jan. 2019 was replaced with a T-3 auction ran in 2020. The State aid judgment removed the European Commission's State aid approval for the Great Britain CM scheme and announced a standstill period until the scheme can be approved again (Proposals for further amendments, 2019). 2021/22 and 2022/23 show the clearing price to be reduced. The cause of the low clearing price was that the auction was very well met. The low prices were unable to attract the development of new plants and secure new-build capacity. The recent clearing price shows a much more attractive figure at 15.97 £/kW.

Capacity providers must deliver electricity at times of system stress (i.e., System Stress Events) or face penalties. Capacity providers may also receive additional payments if exceeding the capacity obligation (i.e., over-deliver). **Energy storage can participate in CM**, along with other technologies (see Table 1).

3.3. Critical summary of the UK policy scheme

According to "6.10.4. Voluntary termination for Generating CM Units transferring to CfD or Renewable Obligation" in the CM Rules

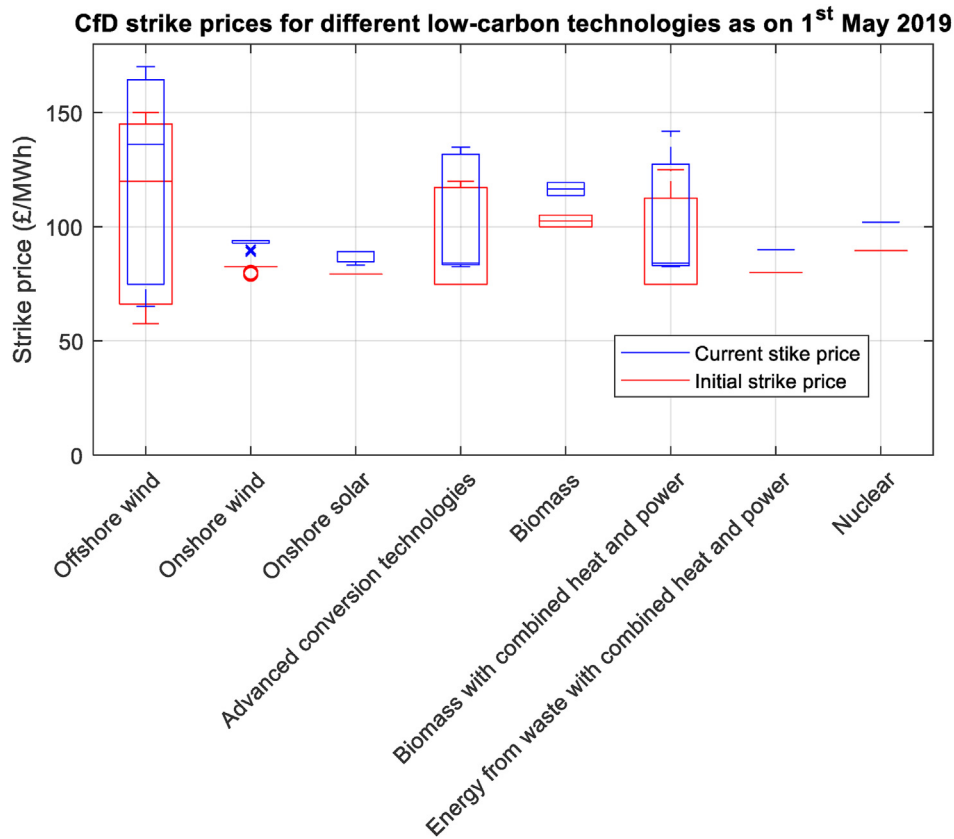

Fig. 5. Initial and current strike prices for low-carbon technologies (Download current and historical).

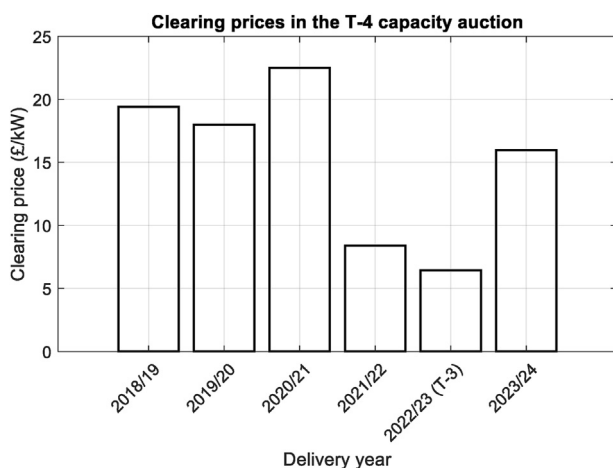

Fig. 6. Clearing prices in the T-4 capacity auction (Capacity market five year review, 2019; Auction results).

2014 (The Capacity Market, 2018), a project cannot participate in CM and CfD schemes simultaneously. Table 1 highlights the differences between the two schemes, where CM and CfD provide short-term and long-term incentives, respectively. Table 1 also presents an overview of the policy mechanisms since 1990, after Electricity Act 1989 and the privatisation of the electricity supply industry in Great Britain. The four policies of interest are Non-Fossil Fuel Obligation/Scottish Renewable Obligation, feed-in tariff, Renewable Obligation, and Electricity Market Reform (CM and CfD). For long-term incentivisation, CfD replaces both Renewable

Obligation and feed-in tariff schemes for any size of eligible low-carbon generation, with nuclear and carbon capture and storage as an addition to the eligible technologies.

The low-carbon energy policies for other EU countries are examined for comparison purposes. RES LEGAL Europe (About RES LEGAL Europe), an initiative of the European Commission provides information on support schemes, grid issues and policies regarding renewable energy sources in the European Union (EU) 28 Member States, the European Free Trade Association countries and some EU Accession Countries. Table 2 presents the policies to incentivise low-carbon power generation for relevant European countries.

In summary, the review has demonstrated that there are mechanisms in place to support low-carbon power generations across Europe especially for renewables. However, the number of incentive schemes for energy storage is still relatively low as compared to generation.

The energy landscape has changed significantly with the implementation of several schemes. In 2018, in the UK, low-carbon power generation had surpassed fossil fuel-based power generation for the first time. Energy storage will play a vital role in the future power system to provide grid services and increase renewable energy utilisation; however, as shown in the next section, more dedicated policies are needed.

4. Modelling the unintended effect of energy policies

This section shows how low-carbon power generation policies, specifically Electricity Market Reform (including CfD) could unintentionally undermine the economic viability of integrated energy storage. In particular, this section firstly provides an analytical method and secondly uses the method to scrutinise a case study.

Table 1
Comparison between the four energy policy schemes since 1990 in the UK.

	Non-Fossil Fuel Obligation/Scottish Renewable Obligation	Renewable Obligation	Feed-in tariff	Electricity Market Reform	
				CfD	CM
Eligible technologies	Wind, hydro, landfill gas, sewage gas, combined heat and power, biomass, nuclear, and anaerobic digestion (Mitchell, 2000).	Anaerobic digestion, biomass, combined heat and power, hydro, tidal, wind, photovoltaic, landfill gas, sewage gas, and wave (Guidance for generators, 2019).	Wind, solar, combined heat and power, hydro, and anaerobic digestion (About the FIT scheme).	Anaerobic digestion, biomass, combined heat and power, hydro, tidal, wind, photovoltaic, landfill gas, sewage gas, and wave, carbon capture and storage, and nuclear (Annex B).	Combined cycle gas turbines, coal/biomass, hydro, open-cycle gas turbine and reciprocating engines (gas and diesel), interconnector, combined heat and power, demand-side response, nuclear, and energy storage (Contracts for Difference, 2017b).
Active period	1990–1998 (Mitchell, 2000).	2002–2017 (About the RO).	2010–2019 (About the FIT scheme).	2014–now (Electricity Market Reform (EMR), 2017).	
Max length of contract (years)	21 (Mitchell, 2000).	20 (Grimwood and Ares, 2016).	20 (10 years for combined heat and power) (Applicants).	15 (Annex B).	One (can be planned for one year ahead or four years ahead) (Contracts for Difference, 2017b).
Description	Non-Fossil Fuel Obligation legislation required the former public electricity suppliers to procure electricity from renewable generators.	The UK electricity suppliers are obliged to get an increasing proportion of their electricity from renewable sources by purchasing Renewables Obligation Certificates from renewable generator companies.	Investment is supported in small-scale renewable generation such as in residential and domestic areas. A fixed-rate (£/kWh) is paid to generator owners for the generated renewable energy. There is an option to export surplus electricity for additional payments.	Investment is supported in existing and new low-carbon generation technologies. The generator companies sell the electricity to the wholesale market. Low-carbon Contracts Company will pay or receive payments from the generator company based on the difference of the strike price and reference price.	A “technology-neutral mechanism” as existing generating capacity competes against new-build, demand-side response, and energy storage. The auction determines the best mix of capacity available in the market, according to the best value for consumers (Contracts for Difference, 2017b).
Installation size	Any (up to 1500 MW in total) (Mitchell, 2000).	Any (Guidance for generators, 2019).	Up to 5 MW (About the FIT scheme).	Up to 1500 MW (CFD contract).	Any (Contracts for Difference, 2017b).
Source of funding	Fossil Fuel Levy on all electricity bills paid for by electricity consumers (Mitchell, 2000).	By electricity suppliers, from a levy on consumers' energy bills (Third part and industry charges).	Up to 5 MW (About the FIT scheme).	Supplier Obligation mechanism (Electricity market reform).	Settlement Costs Levy and the Capacity Market Supplier Charge (G15 - Capacity Market, 2018).

Table 2
Energy policies to incentivise low-carbon power generation for five European countries (About RES LEGAL Europe).

	UK	Germany	Denmark	France	Belgium
Mechanisms	CfD, feed-in tariff, capacity market	Renewable energy surcharge (EEG) feed-in tariff, KfW Renewable Energy Programme, BMU innovation programme, market premium, flexibility premium, flexibility surcharge, tenant electricity surcharge, sliding feed-in premium	Loan guarantees, net-metering, tender scheme	Feed-in tariff, premium tariff (compensation mechanism), tenders, tax regulation mechanisms (income tax credit)	Net metering, green certificates, subsidy
Eligible technology	Table 1	Solar, offshore and onshore wind, hydro, biomass including cogeneration, PV, and geothermal, battery storage	Offshore and onshore wind farms, biogas, biomass, solar, wave, tidal, hydro	Wind, solar, biogas, hydro, geothermal, biomass	Wind, solar, geothermal, biogas, hydro, biomass
Source of funding	Table 1	Electricity consumers, KfW Bankengruppe, plant operator	Electricity consumers and Public Service Obligation, state budget (Danish Energy Agency)	Electricity consumers, Public Service Obligation, state	Electricity consumers and state budget

4.1. Relationship between CfD strike price and energy storage profitability

This section shows how the CfD scheme for low-carbon infrastructures impacts on energy storage economics. This approach considers the operating cost and revenue. The rationale is that if the operations are not at least profitable, then the overall investment will not be, since there is at least the capital cost has to be paid for. In this scenario, a generator has the choice to sell its electricity to the market (at wholesale price or CfD, depending from the case considered) or store it, and the energy storage can sell electricity to the wholesale market.

Without loss of generality, it is assumed that E_{In} is the electricity (MWh) stored in energy storage priced at the opportunity cost of

not selling to the wholesale market (MWh), E_{Out} is the energy sold to the wholesale market (MWh), η is the efficiency of the energy storage (%), C_{In} is the cost of buying the electricity (£), R_{Out} is the revenue for selling the electricity (£), P_{Upper} is the upper bound wholesale price (£/MWh), P_{Lower} is the lower bound wholesale price (£/MWh), and the following equation stipulates the relationship between price, energy, and revenue.

$$E_{Out} = E_{In} \cdot \eta \quad (3)$$

$$C_{In} = E_{In} \cdot P_{Lower} \quad (4)$$

$$R_{Out} = E_{Out} \cdot P_{Upper} = E_{In} \cdot \eta \cdot P_{Upper} \quad (5)$$

$$P_{Lower} = P_{Upper} - \Delta P \quad (6)$$

To be profitable, the cash from selling electricity should be greater than the opportunity cost, i.e., $R_{Out} > C_{In}$,

$$E_{In} \cdot \eta \cdot P_{Upper} > E_{In} \cdot P_{Lower} \quad (7)$$

$$\eta > \frac{P_{Lower}}{P_{Upper}} \quad (8)$$

By substituting Eq. (6) into Eq. (8)

$$\eta > 1 - \frac{\Delta P}{P_{Upper}} \quad (9)$$

Let n to be the total duration (e.g. 8760 h), P_{Max} and P_{Min} are the maximum and minimum wholesale price (£/MWh) and t to be the time interval; the average wholesale price, P_{Avg} is depicted in Fig. 7 and calculated with Eq. (10).

$$P_{Avg} \approx \frac{1}{n} \sum_{t=1}^n P_t \approx \frac{P_{Max} + P_{Min}}{2} \quad (10)$$

By substituting Eq. (10) into Eq. (8),

$$\eta > \frac{2 \cdot P_{Avg}}{P_{Upper}} - 1 \quad (11)$$

Fig. 7 graphically illustrates the relationship between the strike price and the wholesale price. The three regions in the wholesale price influencing the energy storage value when CfD exists are identified as follows:

Region 1: The CSP is below the average wholesale price. There is no value in storing energy with energy storage and sell it to the wholesale market at a high price since the generator will make the same or higher revenue for selling the energy throughout the day. Therefore, P_{CfD} should be greater than P_{Avg} for CfD to be meaningful to generators.

Region 2: The CSP is above the average wholesale price but lower than the upper bound wholesale price. According to the above logical reasoning and derivation, it concludes that for energy storage to be

valuable, $P_{Upper} > P_{CfD} > P_{Avg}$. In addition to rearranging Eq. (11), the CSP, P_{CfD} should satisfy the following condition:

$$P_{Upper} > P_{CfD} > \frac{(\eta + 1) \cdot P_{Upper}}{2} \quad (12)$$

Eq. (12) shows that the maximum CSP is linked to the efficiency of energy storage. This is both an economic and physical limitation on the implementation of energy storage. If the efficiency is low, then there is an incentive using energy storage for price arbitrage. Fig. 8 presents the hourly day-ahead auction prices for the UK in 2019. The wholesale electricity price data satisfy the normal distribution. Based on the law of large numbers, the proposed method can be applied to the wholesale market in the UK when considering the study to be long-term.

Region 3: The strike price is higher than the upper bound wholesale price. Energy storage has no value as the profit from the wholesale market is always less than the CfD (moreover there are energy storage costs (capital and Operation and Maintenance (O&M)) and energy losses (efficiency)). Therefore, P_{CfD} should be less than P_{Max} to retain the usefulness of energy storage (from profitability perspective).

4.2. Case study

GIES systems are intended to store a large amount of energy (several MW) (Garvey et al., 2015a). Thermal options are, technologically, the more simple and investigated ways to store several MW (Garvey et al., 2015b), particularly when the production is coupled with the storage. Nuclear power plants are the most relevant low-carbon infrastructure that involved the production of consistent thermal power. Among the different types of nuclear power plants, we chose to use Small Modular Reactors as they are novel, but increasingly popular between scientists, industry and policymakers.

Small Modular nuclear Reactors (SMRs) are “newer generation (nuclear) reactors designed to generate electric power up to 300 MW, whose components and systems can be shop fabricated and then transported as modules to the sites for installation as demand arises” (Advances in small modular, 2018). Different from conventional reactors, SMRs are “reactor designs that are deliberately small, i.e., designs that do not scale to large sizes but rather capitalise on their smallness to achieve specific performance characteristics” (Ingersoll,

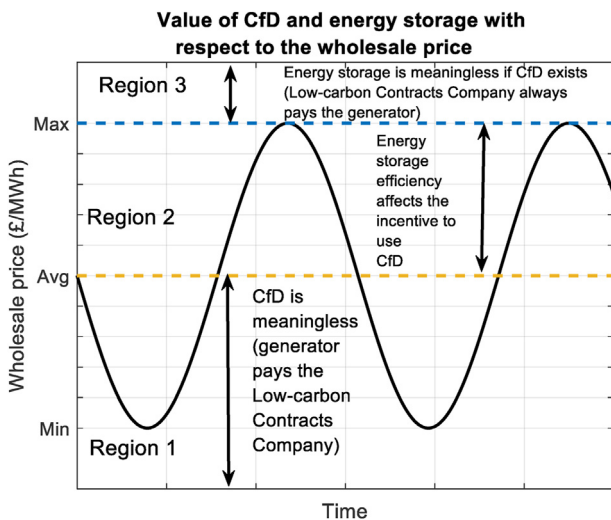

Fig. 7. The wholesale price and strike price (for illustration purposes).

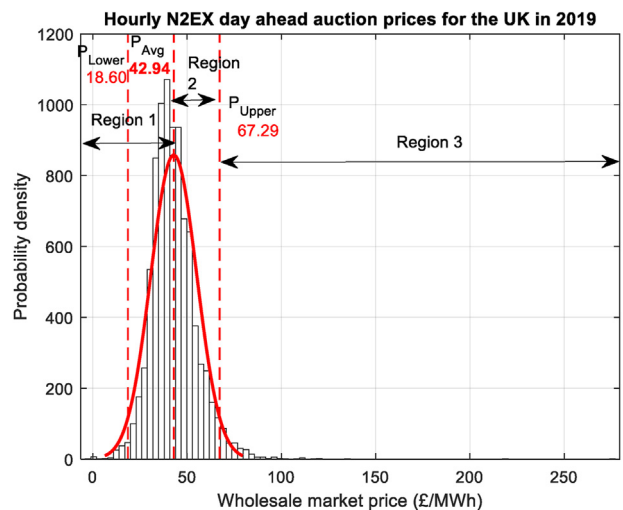

Fig. 8. The wholesale electricity price for the UK in 2019 (N2EX day ahead auction prices).

2009). The UK government is strongly interested in the technology; Department of Business Energy and Industrial Strategy (one of its departments) has set out a clear direction for advanced nuclear technologies via the “Advanced Nuclear Technologies” framework (Advanced Nuclear Technologies, 2019). The framework aims to encourage the development of advanced nuclear technologies and consists of the following elements: financing, advanced modular reactor R&D programme, regulatory readiness, land access and siting, and supply chain development. In 2017, Department of Business Energy and Industrial Strategy launched the advanced modular reactor feasibility and development project for 44 M€ to understand and identify the technical feasibility and commercial viability of modular reactor designs (Advanced Nuclear Technologies, 2019).

Previous research projects stressed the importance of load following (Locatelli et al., 2018) and energy storage for SMRs (Edwards et al., 2016). Nowadays, several SMRs are at the feasibility study stage in many countries (UK, USA, Canada, China, India, Argentina, Russia, etc.). The global market potential for low-carbon and low-cost SMRs is estimated to be worth 250 B€ to 400 B€ by 2035 (Mignacca and Locatelli, 2020). Mignacca et al. (2020) presented a key element in the feasibility studies of all these countries is the support from the national Government. For all these reasons, we chose to use an SMR in this case study.

By inserting control rods into the reactor active zone, the power output in nuclear power plants, including SMRs, can be adjusted. However, frequently reducing nuclear power output is not ideal as: 1) nuclear power generation consists mainly of fixed and sunk costs, reducing the power output doesn't reduce generating costs; 2) the plant is thermo-mechanically stressed with long-term issues (Locatelli et al., 2015). Reducing power of nuclear reactors is unfortunately non-infrequent. For example, France has a high penetration of nuclear power plants; some need to have the power to be routinely reduced to meet the daily load curve (Zhang et al., 2020). Another example is Germany, where nuclear power plants must operate in a load-following mode to balance the fluctuations of power generation (Zhang et al., 2020). Since providing a constant and full power output is the most cost-efficient option, energy storage is needed to reduce the curtailment of nuclear power.

4.2.1. Key assumptions and inputs

This section presents economic and financial analyses for SMR-only, GIES, and non-GIES. GIES and non-GIES consist of thermal energy storage and Lithium-ion battery, respectively.

As depicted in Fig. 9, the two revenue sources considered are the wholesale market and CfD. For non-GIES, the SMR and battery can be seen as two independent entities. There is an option to store the electricity for sale to the wholesale market. GIES (for the thermal energy storage to be “built-in” the SMR plant) is a technology not included in Electricity Market Reform. Therefore, this paper makes the reasonable assumption of a scenario where the SMR sells the electricity to CfD and the energy of the thermal energy storage to the wholesale market. The turbine generator is sized according to the combined power rating of the SMR and thermal energy storage, at a ratio of 1.2 (as the thermal energy storage is approx. 20% of the SMR rating), known as the “electricity generation power rating” for GIES (Garvey et al., 2015a).

Table 3 presents the technical, economic and financial input for the SMR technology in GIES and non-GIES. The complete list of model inputs (e.g., specific overnight cost of energy storage and storage efficiency) is presented in (Lai and Locatelli, 2019). Fig. 10 depicts the critical relationships between stakeholders in the financial model with Discounted Cash Flow (DCF). The financing consists of a mix of equity and debt. Sainati et al. (2020) presented an overview of the financing mechanism for large infrastructure,

focusing in particular on the legal and regulatory barriers in (Sainati et al., 2019).

The model computes key metrics including:

1. **Levelized Cost of Electricity (LCOE):** This is the electricity price required to provide the revenue to repay the life cycle cost. The formulation is (Lai and McCulloch, 2017):

$$\text{LCOE} \left[\frac{\text{£}}{\text{MWh}} \right] = \frac{\sum_{n=0}^N \frac{C_{\text{cap}n} + C_{\text{O\&M}n}}{(1+WACC)^n}}{\sum_{n=0}^N \frac{E_n}{(1+WACC)^n}} \quad (13)$$

Where C_{cap} is the capital cost [£], $C_{\text{O\&M}}$ is the operational and maintenance cost [£], E is the system energy output [MWh], and N is the system lifetime [years]. The LCOE is computed with the earnings before interest and taxes cash flow. The cash flow for the LCOE is discounted at the discount rate or the Weighted Average Cost of Capital (WACC) (Levelized cost and levelized, 2019). The WACC calculation is in (Lai et al., 2019):

$$\text{WACC} = K_E \cdot \theta_{\text{CAPEX}} + K_D \cdot (1 - \theta_{\text{CAPEX}}) \cdot (1 - \theta_{\text{Tax}}) \quad (14)$$

Where K_E is the cost of equity [%] and K_D is the cost of debt [%] which are relative to the investment risk. θ_{CAPEX} is the equity share on CAPEX [%] and θ_{Tax} is the effective tax rate [%]. Policymakers and engineers use the LCOE in comparing the techno-economic performance of technologies and approximating the electricity sales price for the technology to break-even.

2. **Net Present Value (NPV) to the equity:** This is the sum of the levered cash flows. Discounting the “free cash flow to the equity” at the cost of equity provides the NPV to the equity. NPV to the equity is the NPV from the viewpoint of equity holders (i.e. the “owners of the energy storage”) after the debt has been repaid to the debt holders. The equity holders obtain a payment equivalent to the cost of equity if the NPV is zero.

The hypotheses for the economic and financial analyses are as follows:

- The SMR size is 300 MW
- The number of Lithium-ion battery and thermal energy storage replacements are 5 (every 12 years) and 3 (every 20 years), respectively (Lai and Locatelli, 2019)
- The electricity stored will be sold during the peak at an upper bound wholesale price.
- The CfD lasts for 35 years (Hinkley Point, 2017)

5. Results

This section presents the results from the cash flow modelling. The most likely values are used as inputs. The model outputs the NPV to equity for SMR-only, GIES, and non-GIES based on different CfD strike price. The implications of setting the strike price with the existence of the energy storage are presented in Section 5.1.

SMR's LCOE is calculated to validate the discounted cash flow model. The calculated LCOE for the SMR is 0.073 £/kWh which is consistent with the literature (Mignacca and Locatelli, 2020).

The LCOEs for GIES and non-GIES are 0.091–0.098 £/kWh and 0.101–0.197 £/kWh, respectively, for 100–1000 MWh energy storage. This is reasonable since the capital cost of thermal energy storage is much lower (capital cost at 18.65 £/kWh) than Lithium-ion battery (capital cost at 396 £/kWh) (Lai and Locatelli, 2019). The LCOE for non-GIES is much greater than GIES due to the high capital cost for the Lithium-ion battery.

There are LCOE studies related to energy systems with energy storage and low-carbon power generators. The LCOEs is

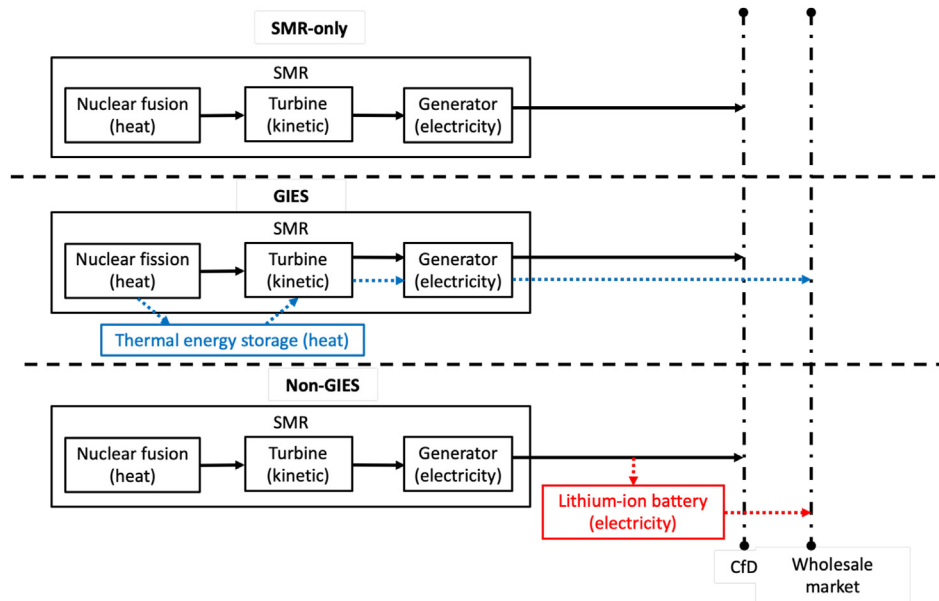

Fig. 9. Energy transformation, transmission and revenue sources for the three system configurations with SMR.

Table 3
Technical, economic, and financial inputs for SMR.

Inputs	Min.	Most likely	Max.	Note and reference
Technical Capacity factor [%]	75	90	95	The flexibility requirement can affect the capacity factor, and higher flexibility (e.g., load-following) can give a lower capacity factor (Mignacca and Locatelli, 2020).
Construction time [yr]	3	4	5	SMRs on average have a shorter construction time than large reactors (Mignacca and Locatelli, 2020).
Economic System life (excluding construction) [yr]	50	60	70	Mignacca and Locatelli (2020).
Specific fixed O&M power cost for generator (C _{O&M-Gen}) [k€/MW-yr]	57	87	144	The most likely value is from (Iyer et al., 2014); the max and min values are obtained from cost estimation class 5 (Dysert et al., 2016).
Specific overnight cost for generator [€/kW]	2145	3300	5545	According to several SMR designs (e.g., pressurised water reactor and sodium-cooled fast reactor) (Mignacca and Locatelli, 2020).
Financing Cost of debt [%]	6	9	12	(Locatelli and Mancini, 2010; Locatelli et al., 2014).
Cost of equity [%]	11	12	15	

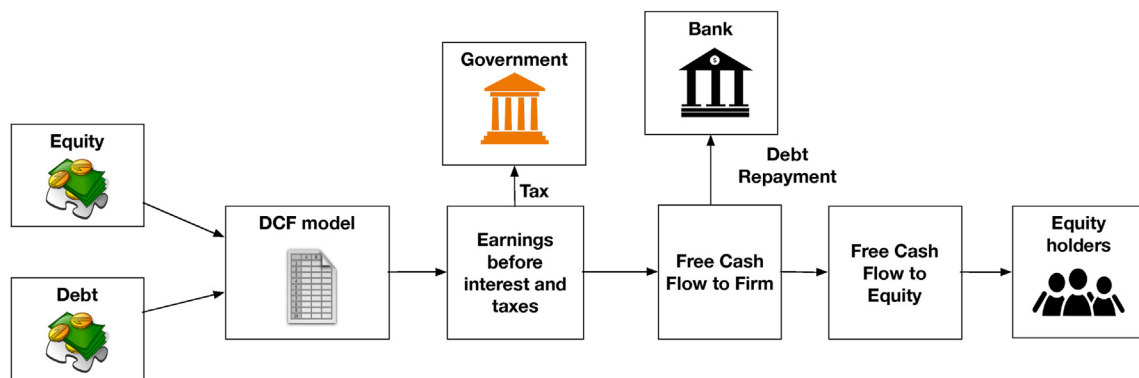

Fig. 10. Schematic of the financial model for GIES and non-GIES studies. Adopted from (Lai et al., 2019).

comparable to previous research. For instance, Mundada et al. (2016) calculated the LCOE for a kilowatt hybrid energy system with photovoltaic, battery and combined heat and power. At a 10% discount rate, the LCOE is between 0.20 €/kWh and 0.26 €/kWh with a loan term of 5 years and 25 years respectively. The deep-cycle lead-acid battery replacement happens every 10 years. Malheiro et al. (2015) calculated the LCOE for a kilowatt hybrid

energy system (with battery, wind, photovoltaic and diesel generators) to be 0.18 €/kWh. For the off-grid system, the photovoltaic generator occupies most of the installed capacity and cost. Similarly, the replacement happens every 10 years for the lead-acid battery.

Tables 4 and 5 present the NPV to equity for GIES and non-GIES with SMR, respectively. The sensitivity analysis considers the

energy storage capacity and CfD's CSP. For SMR only, the NPV is negative when the CSP is less than the wholesale price. This corresponds to Region 1 and is consistent with the analytical method derived in Section 4.1. When CSP is greater than the maximum wholesale price, the SMR-only system has a positive NPV and is more bankable than GIES and non-GIES. This corresponds to the explanation in Region 3 that energy storage (GIES and non-GIES) is meaningless as Low-carbon Contracts Company always pays SMR.

When the CSP is between the average and maximum wholesale price (Region 2), it is reminded that with a higher CSP (as the CSP approaches the maximum wholesale price), energy storage has less margin to perform energy arbitrage and be as competitive as CfD (a fixed-steam revenue). In other words, low CSP makes energy storage competitive. According to the case study, SMR-only has a positive NPV when CSP is at 60 £/MWh and the NPV for energy storage (GIES and non-GIES) is always negative with a low CSP. The reason for the negative NPV is that the analytical method does not account for the capital cost, and factoring this shows that energy storage is never economically viable. This is evident for non-GIES as the CSP needs to be between 80 £/MWh and 120 £/MWh, for energy storage capacity between 100 and 500 MWh, respectively. For the less capital intensive energy storage option (GIES), the NPV turns positive when CSP is greater than 80 £/MWh. For the strike price at 100 £/MWh, the net present value for Cases 2 and 3 reduces by 32% (from 863 M£ and 400%, respectively, when the energy storage capacity increases from 100 MWh to 1 GWh. Therefore, energy policy mechanism needs to be in place to promote energy storage regardless of GIES or non-GIES. Nevertheless, the analytical method proposed in Section 4.1 is a very useful indicator for setting the useful CSP (Eq. (12)), as the Government may not want to over incentivise a generator at the cost of taxpayers.

Focusing on the comparison between GIES and non-GIES, the incentives to use CfD are reduced as the CSP is reduced. The NPV reduces as the energy storage capacity increases due to the increased cost and energy losses of the system. For non-GIES, the rate of change for NPV is greater as the energy storage capacity changes due to the high capital cost of the battery and lifetime replacements. For GIES, the NPV is relatively constant under different energy storage capacities due to the lower capital cost and longer lifetime for thermal energy storage.

In general, it is not profitable to use energy storage, even if the wholesale price is higher than the strike price. Fig. 11 shows the percentage of energy delivered to the grid and the revenue obtained from SMR and energy storage. The SMR delivers the largest proportion of electricity and revenue (over 75% of energy and 80% of revenue when energy storage is 1000 MWh). Due to round trip efficiency, the system's energy loss increases as the energy storage capacity increases. The energy loss for non-GIES is constant as energy storage capacity changes, due to the Lithium-ion battery

efficiency is very high (i.e., at 95%). The proportion of revenue for non-GIES is higher than GIES for the same energy storage capacity because of the higher round trip efficiency for Lithium-ion battery. With a larger size of energy storage (e.g., GWh), selling the energy of the energy storage when the wholesale price is high will provide a higher revenue, particularly in case of low CSP. In summary, the results show that energy storage decreases the NPV; the SMR is always better off without any kind of energy storage. Hence, incentive mechanisms are required for energy storage and will be investigated in future work.

6. Conclusions and recommendations

Energy storage is a relevant technology to provide energy system flexibility. This paper showed (A) how policy mechanism (such as CfD) designed to support low-carbon technologies could affect the energy storage adoption and (B) there is a need for energy policy schemes to support and protect the energy storage market.

Energy policies to date have not well addressed or considered energy storage in a long-term effect. Furthermore, this paper shows that CfD for low-carbon power generators can harm the energy storage market if the strike price is set to be above the maximum wholesale price. The strike price also needs to be above the average wholesale price for CfD to be useful. Renewable energy technologies, especially onshore windfarm and solar photovoltaic, have plummeted in cost. However, energy storage systems, in particular batteries, are still expensive, and there are no long-term policy mechanisms in place to promote energy storage growth. Considering the literature and the results of our model, we propose the following mechanisms:

Price floor mechanism for energy storage: A price floor is a regulatory policy, with the Government to enforce price limit or control on how low a price can be charged for a good, service, product, or commodity (Gissey et al., 2019). Price floor mechanisms have been implemented for the energy sector, including for the carbon price (Anuta et al., 2014). In April 2013, the UK Government introduced a carbon price floor to reduce carbon market price uncertainty and worked well with the emissions trading scheme (Anuta et al., 2014). The carbon price floor sets a minimum market price for carbon and was developed to deal with the low-carbon prices in the EU emissions trading scheme, as a consequence by the oversupply of permits and the economic recession. The carbon price has been effective to reduce greenhouse gas emissions by increasing the economic viability of low-carbon technologies.

Generators and energy storage systems influence the wholesale electricity market (Gissey et al., 2019). With greater uncertain power demand and generation due to larger penetration of intermittent renewables and reliance on electricity, wholesale market price volatility is a major challenge to be dealt with. Indeed,

Table 4
NPV to equity for GIES (M£).

CSP (£/MWh)	120	1292	972	944	916	888	860	833	806	778	751	724
	110	1077	765	741	717	693	669	645	621	597	573	550
	100	863	562	541	521	500	480	459	439	419	399	379
	90	652	362	345	328	311	294	277	260	243	226	210
	80	445	166	152	139	125	111	98	85	71	58	44
	70	243	-15	-36	-46	-56	-66	-76	-86	-96	-106	-115
	60	46	-203	-210	-216	-223	-230	-237	-244	-251	-258	-265
	50	-139	-416	-421	-427	-433	-439	-445	-451	-457	-463	-469
	0	100	200	300	400	500	600	700	800	900	1000	
	Energy storage capacity (MWh)											

Table 5
NPV to equity for non-GIES (M£).

CSP (£/MWh)	120	1292	757	579	406	236	69	-95	-252	-404	-556	-726
	110	1077	565	394	226	62	-98	-252	-400	-553	-725	-919
	100	863	376	211	50	-107	-257	-401	-557	-735	-935	-1144
	90	652	189	32	-121	-267	-410	-572	-757	-963	-1207	-1501
	80	445	8	-141	-282	-429	-600	-796	-1016	-1302	-1589	-1875
	70	243	-166	-304	-461	-647	-854	-1131	-1410	-1690	-1970	-2249
	60	46	-340	-516	-722	-989	-1261	-1534	-1806	-2078	-2351	-2623
	50	-139	-615	-876	-1141	-1406	-1672	-1937	-2202	-2467	-2732	-2997
		0	100	200	300	400	500	600	700	800	900	1000
Energy storage capacity (MWh)												

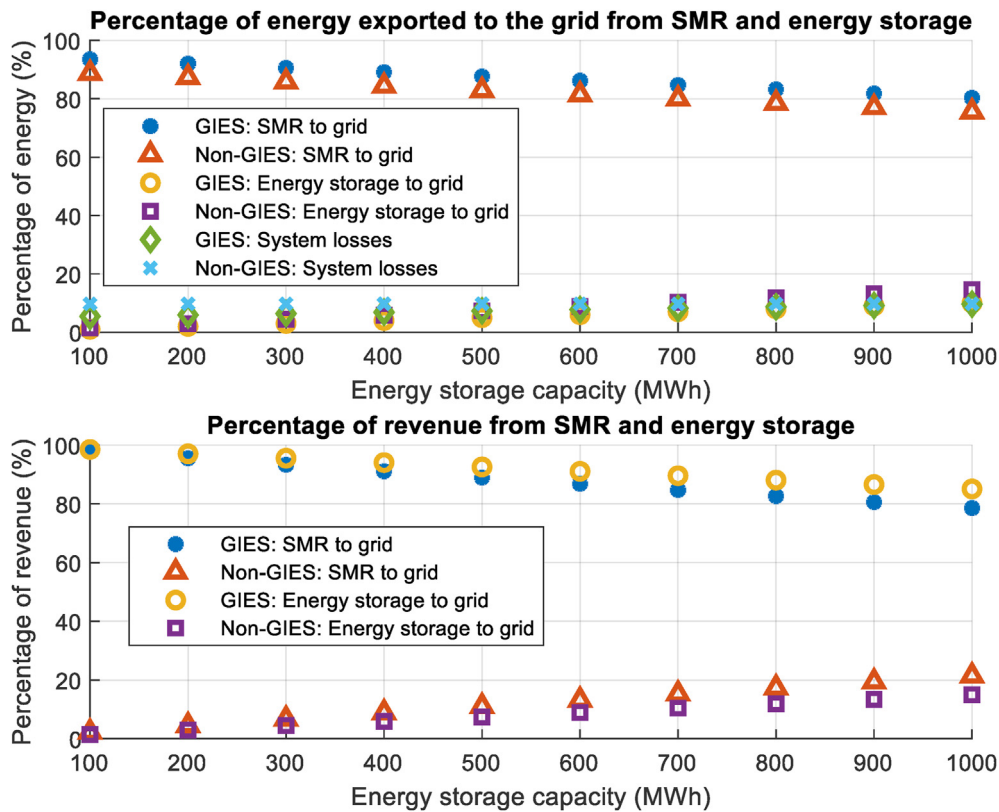

Fig. 11. Percentage of revenue and energy output from SMR and energy storage.

negative wholesale prices have appeared in recent years (N2EX day ahead auction prices).

With a price floor mechanism, the Government may pay the system operator a certain value (P_{pay} £/MWh) to store energy when the wholesale market reaches a level of the low market price (e.g. 20 £/MWh). Consider that many system operators may store the energy driven by the price floor mechanism, the reduction in power generation will increase the wholesale price. The energy stored will be sold during a period of high prices, but given this availability of energy, there will be less shortage of electricity; therefore, the “peak period” will be reduced. In summary, creating a price floor would make GIES system economically viable and, at the same time, contribute to reducing the volatility of the Electricity market.

This opens up research questions such as, “how to define the low market price that triggers the price floor mechanism and the optimal

value of P_{pay} ?” and “how is it possible to establish a fair value for P_{pay} ?”. P_{pay} can be affected by the market arbitrage value, where an increased value will reduce the government payment to make energy storage more economical. The holistic study requires consideration of demand response mechanisms and other grid services of energy storage.

Upfront subsidy to meet energy storage cost: The UK government does not provide direct subsidies for the deployment of large-scale or behind-the-meter energy storage systems (Battery promoting policies, 2018). However, upfront subsidies can promote the development of certain technologies. For instance, the Green Deal was a UK government policy initiative that let the domestic sector to pay for energy-efficient home improvements, including solar panels and heat pumps through the savings on their energy bills (Green Deal, energy). GIES systems could benefit from

comparable initiatives due to the relatively high cost for energy storage and the balance of plant. Similarly, the research question of “How much upfront subsidy is required to promote GIES deployment?” is relevant to be addressed, considering the different energy storage technologies type and system conditions.

CRediT authorship contribution statement

Chun Sing Lai: Conceptualization, Methodology, Software, Investigation, Data curation, Formal analysis, Writing - original draft, preparation, Writing - review & editing. **Giorgio Locatelli:** Conceptualization, Methodology, Validation, Writing - original draft, preparation, Writing - review & editing, Resources, Project administration, Funding acquisition.

Declaration of competing interest

The authors declare that they have no known competing financial interests or personal relationships that could have appeared to influence the work reported in this paper.

Acknowledgements

This work is sponsored by the EPSRC grant “GIES: Generation Integrated Energy Storage: A Paradigm Shift” (EP/P022049/1). The authors express their gratitude to Mr. Benito Mignacca for proof-reading and commenting on the work.

References

- About Res LEGAL Europe. RES LEGAL Europe [Online]. Available: <http://www.res-legal.eu/about-res-legal-europe/>.
- About the FIT scheme. Office of Gas and Electricity Markets (Ofgem) [Online]. Available: <https://www.ofgem.gov.uk/environmental-programmes/fit/about-fit-scheme>.
- About the RO. Office of Gas and Electricity Markets (Ofgem) [Online]. Available: <https://www.ofgem.gov.uk/environmental-programmes/ro/about-ro>.
- Advanced Nuclear Technologies, 2019. A UK Framework. Industrial Strategy [Online]. Available: https://www.cleanenergyministerial.org/sites/default/files/2019-06/BEIS_Advanced_Nuclear_Technologies_2019.pdf.
- Advances in Small Modular, Sept. 2018. Reactor Technology Developments 2018 Edition. International Atomic Energy Agency (IAEA) [Online]. Available: https://aris.iaea.org/Publications/SMR-Book_2018.pdf.
- Amirante, R., Cassone, E., Distaso, E., Tamburrano, P., 2017. Overview on recent developments in energy storage: mechanical, electrochemical and hydrogen technologies. *Energy Convers. Manag.* 132, 372–387.
- An analysis of electricity system, 2016. Flexibility for Great Britain. The Carbon Trust [Online]. Available: https://assets.publishing.service.gov.uk/government/uploads/system/uploads/attachment_data/file/568982/An_analysis_of_electricity_flexibility_for_Great_Britain.pdf.
- Annex B. Annex B: Feed-in Tariff with Contracts for Difference: Draft Operational Framework," Gov.UK [Online]. Available: https://assets.publishing.service.gov.uk/government/uploads/system/uploads/attachment_data/file/48373/5358-annex-b-feedin-tariff-with-contracts-for-differe.pdf.
- Anuta, O.H., Taylor, P., Jones, D., McEntee, T., Wade, N., 2014. An international review of the implications of regulatory and electricity market structures on the emergence of grid scale electricity storage. *Renew. Sustain. Energy Rev.* 38, 489–508.
- Applicants. Applicants: Which Technologies are Eligible for FITs?," Office of Gas and Electricity Markets (Ofgem) [Online]. Available: <https://www.ofgem.gov.uk/environmental-programmes/fit/applicants>.
- Auction results. National Grid [Online]. Available: <https://www.emrdeliverybody.com/CM/Auction-Results-1.aspx>.
- Barkatullah, N., Ahmad, A., 2017. Current status and emerging trends in financing nuclear power projects. *Energy Strat.* 18, 127–140.
- Bataille, C., et al., 2018. A review of technology and policy deep decarbonization pathway options for making energy-intensive industry production consistent with the Paris Agreement. *J. Clean. Prod.* 187, 960–973.
- Battery promoting policies, June 2018. Battery promoting policies in Selected Member States. N° ENER C2/2015-410, European Commission [Online]. Available: https://ec.europa.eu/energy/sites/ener/files/policy_analysis_-_battery_promoting_policies_in_selected_member_states.pdf.
- Budget notice for CFD, Oct. 2014. Allocation Round 1. Department for Business, Energy & Industrial Strategy [Online]. Available: https://assets.publishing.service.gov.uk/government/uploads/system/uploads/attachment_data/file/360129/CFD_Budget_Notice.pdf.
- Capacity market five year review, 2019. Capacity market five year review (2014-2019). Department for Business, Energy & Industrial Strategy, UK [Online]. Available: https://assets.publishing.service.gov.uk/government/uploads/system/uploads/attachment_data/file/819760/cm-five-year-review-report.pdf.
- Castagneto Gissey, G., Dodds, P.E., Radcliffe, J., 2018. Market and regulatory barriers to electrical energy storage innovation. *Renew. Sustain. Energy Rev.* 82, 781–790.
- Cebulla, F., Haas, J., Eichman, J., Nowak, W., Mancarella, P., 2018. How much electrical energy storage do we need? A synthesis for the US, Europe, and Germany. *J. Clean. Prod.* 181, 449–459.
- CFD contract. Low Carbon Contracts Company, Electricity Settlements Company [Online]. Available: <https://www.lowcarboncontracts.uk/cfd-contract>.
- Clean energy investment trends, 2018. BloombergNEF. Jan. 2019. [Online]. Available: <https://data.bloomberglp.com/professional/sites/24/BNEF-Clean-Energy-Investment-Trends-2018.pdf>.
- Climate Change Act 2008. Climate Change Act 2008," Legislation.gov.uk [Online]. Available: <https://www.legislation.gov.uk/ukpga/2008/27/contents>.
- Climate Change and Sustainable Energy Act, 2006. Climate change and sustainable energy act. legislation.gov.uk. [Online]. Available: <https://www.legislation.gov.uk/ukpga/2006/19/contents>.
- Consultation outcome: the Planning System for Electricity Storage: Follow up Consultation," Department for Business, Energy & Industrial Strategy [Online]. Available: <https://www.gov.uk/government/consultations/the-planning-system-for-electricity-storage-follow-up-consultation>.
- Contracts for Difference: an EMR CFD Primer, Oct. 2015. Clifford Chance [Online]. Available: https://www.cliffordchance.com/briefings/2015/10/contracts_for_differenceanemrcfdprimer.html.
- Contracts for Difference: Allocation Framework for the Second Allocation Round, March 2017. Department for Business, Energy & Industrial Strategy [Online]. Available: https://assets.publishing.service.gov.uk/government/uploads/system/uploads/attachment_data/file/601120/Allocation_Framework_for_the_second_Allocation_Round.pdf.
- Contracts for Difference and Capacity Market Scheme Update 2017, 2017. Department for Business, Energy & Industrial Strategy [Online]. Available: https://assets.publishing.service.gov.uk/government/uploads/system/uploads/attachment_data/file/663901/hc537-contracts-for-difference-and-capacity-market-scheme-update-2017.pdf.
- Contracts for Difference: Methodology Used to Set Administrative Strike Prices for CFD Allocation Round 3, Dec. 2018. Department for Business, Energy & Industrial Strategy [Online]. Available: https://assets.publishing.service.gov.uk/government/uploads/system/uploads/attachment_data/file/765690/Admin_Strike_Prices_Methodology_AR3.pdf.
- Contracts for Difference: Generator Guide," Low Carbon Contracts Company [Online]. Available: <https://www.lowcarboncontracts.uk/sites/default/files/publications/Contracts%20for%20Difference%20-%20Generator%20Guide%20Feb%202019.pdf>.
- Country nuclear power profiles: United Kingdom," International Atomic Energy Agency [Online]. Available: <https://cnpp.iaea.org/countryprofiles/UnitedKingdom/UnitedKingdom.htm>.
- Digest of UK Energy Statistics DUKES, 1991. Digest of UK Energy Statistics (D): Chapter 6 Statistics on Energy from Renewable Sources. Department for Business, Energy & Industrial Strategy, Gov.UK [Online]. Available: <https://www.gov.uk/government/statistics/renewable-sources-of-energy-chapter-6-digest-of-uk-energy-statistics-dukes>.
- Distribution Connection, 2012. Distribution Connection and Use of System Agreement (DCUSA) DCP108- Availability of the Non-intermittent Generator Tariff. Office of Gas and Electricity Markets [Online]. Available: <https://www.ofgem.gov.uk/ofgem-publications/62523/dcp108.pdf>.
- Download Current and Historical. Download current and historical CFD Register Data," Low Carbon Contract Company, Electricity Settlements Company [Online]. Available: <https://www.lowcarboncontracts.uk/download-current-and-historical-cfd-register-data>.
- Dysert, L., Bowman, L., Bredehoeft, P., Melamed, D., Pickett, T., Plumery, R., March 2016. Cost estimate classification system - as applied in engineering, procurement, and construction for the process industries. AACE International Recommended Practice No. 18R-97. [Online]. Available: https://web.aacei.org/docs/default-source/toc/toc_18r-97.pdf?sfvrsn=4.
- Edwards, J., Bindra, H., Sabharwal, P., 2016. Exergy analysis of thermal energy storage options with nuclear power plants. *Ann. Nucl. Energy* 96, 104–111.
- Electricity market reform: CFD Supplier Obligation," Gov.UK [Online]. Available: <https://www.gov.uk/government/collections/electricity-market-reform-cfd-supplier-obligation>.
- Electricity Market Reform EMR, Dec. 2017. Office of gas and electricity markets (Ofgem) [Online]. Available: <https://www.ofgem.gov.uk/electricity/wholesale-market/market-efficiency-review-and-reform/electricity-market-reform-emr>.
- Energy Storage. Energy storage: Tracking clean energy progress," International Energy Agency (IEA) [Online]. Available: <https://www.iea.org/tcep/energyintegration/energystorage/>.
- Fast Reserve "Fast reserve," Nat. Grid, [Online]. Available: <https://www.nationalgrideso.com/balancing-services/reserve-services/fast-reserve>.
- Firm Frequency Response FFR. National Grid [Online]. Available: <https://www.nationalgrideso.com/balancing-services/frequency-response-services>.
- Forrester, S.P., Zaman, A., Mathieu, J.L., Johnson, J.X., 2017. Policy and market barriers to energy storage providing multiple services. *Electr. J.* 30 (9), 50–56.

- Future energy scenarios July 2020. Nat. Grid, 2020 [Online]. Available: <https://www.nationalgrideso.com/future-energy/future-energy-scenarios/fes-2020-documents>.
- Future energy scenarios July 2019. Nat. Grid, 2020 [Online]. Available: <https://www.nationalgrideso.com/future-energy/future-energy-scenarios/fes-2019-documents>.
- G15 - Capacity Market, March. 2018. G15 - Capacity Market supplier Payments EMRS Guidance Public. EMR Settlement Limited, Electricity Settlements Company [Online]. Available: <https://www.emrsettlement.co.uk/documentstore/guidance/g15-cm-supplier-payments.pdf>.
- G17 - Capacity provider payments EMRS Guidance, March 2018. EMR Settlement Limited, Electricity Settlements Company [Online]. Available: <https://www.emrsettlement.co.uk/documentstore/guidance/g17-capacity-provider-payments.pdf>.
- Garvey, S.D., et al., 2015a. On generation-integrated energy storage. *Energy Pol.* 86, 544–551.
- Garvey, S.D., et al., 2015b. Analysis of a wind turbine power transmission system with intrinsic energy storage capability. *Wind Eng.* 39 (2), 149–173.
- Ghorbani, B., Mehrpooya, M., Ardehali, A., 2020. Energy and exergy analysis of wind farm integrated with compressed air energy storage using multi-stage phase change material. *J. Clean. Prod.* 120906.
- Gissey, G.C., Subkhankulova, D., Dodds, P.E., Barrett, M., 2019. Value of energy storage aggregation to the electricity system. *Energy Pol.* 128, 685–696.
- Green Deal. Green deal: energy saving for your home," gov.uk [Online]. Available: <https://www.gov.uk/green-deal-energy-saving-measures>.
- Grimwood, G.G., Ares, E., July 2016. Energy: the Renewables Obligation. Briefing paper: 05870. House of Commons Library [Online]. Available: <http://researchbriefings.files.parliament.uk/documents/SN05870/SN05870.pdf>.
- Guidance for generators that Receive or Would like to Receive Support under the Renewables Obligation (RO) Scheme, April 2019. Office of Gas and Electricity Markets (Ofgem) [Online]. Available: https://www.ofgem.gov.uk/system/files/docs/2019/04/ro_generator_guidance_apr19.pdf.
- Hatzilygyriou, N.D., Dimeas, A., Tsikalakis, A.G., Lopes, J.P., Karniotakis, G., Oyarzabal, J., 2005. Management of microgrids in market environment. In: 2005 International Conference on Future Power Systems. IEEE, p. 7, 7.
- Hinkley Point, C., June 2017. National Audit Office. Department of Business, Energy & Industrial Strategy [Online]. Available: <https://www.nao.org.uk/wp-content/uploads/2017/06/Hinkley-Point-C.pdf>.
- Historical Electricity Data. Historical electricity data: 1920 to 2017," department for business, energy & industrial strategy, gov.uk [Online]. Available: <https://www.gov.uk/government/statistical-data-sets/historical-electricity-data>.
- Ingersoll, D.T., 2009. Deliberately small reactors and the second nuclear era. *Prog. Nucl. Energy* 51 (4), 589–603.
- Interim report into the low frequency demand Disconnection (LFDD) Following Generator Trips and Frequency Excursion on 9 Aug 2019, Aug. 2019. National Grid [Online]. Available: https://www.ofgem.gov.uk/system/files/docs/2019/08/incident_report_lfdd_-_summary_-_final.pdf.
- Iyer, G., Hultman, N., Fetter, S., Kim, S.H., 2014. Implications of small modular reactors for climate change mitigation. *Energy Econ.* 45, 144–154.
- Jo, B.-K., Jung, S., Jang, G., 2019. Feasibility analysis of behind-the-meter energy storage system according to public policy on an electricity charge discount program. *Sustainability* 11, 186.
- Kim, J., Dvorkin, Y., 2018. Enhancing distribution system resilience with mobile energy storage and microgrids. *IEEE Trans. Smart Grid* 10 (5), 4996–5006.
- Kozlov, N., 2014. Contracts for Difference: risks faced by generators under the new renewables support scheme in the UK. *J. World Energy Law Bus.* 7 (3), 282–286.
- Lai, C.S., Locatelli, G., Nov 2019. Economic and financial appraisal of novel large-scale energy storage technologies. Submitted Energy.
- Lai, C.S., McCulloch, M.D., 2017. Levelized cost of electricity for solar photovoltaic and electrical energy storage. *Appl. Energy* 190, 191–203.
- Lai, C.S., 2019. A robust correlation analysis framework for imbalanced and dichotomous data with uncertainty. *Inf. Sci.* 470, 58–77.
- Lai, C.S., Jia, Y., Lai, L.L., Xu, Z., McCulloch, M.D., Wong, K.P., 2017. A comprehensive review on large-scale photovoltaic system with applications of electrical energy storage. *Renew. Sustain. Energy Rev.* 78, 439–451.
- Lai, C.S., Locatelli, G., Pimm, A., Tao, Y., Li, X., Lai, L.L., 2019. A financial model for lithium-ion storage in a photovoltaic and biogas energy system. *Appl. Energy* 251, 113179.
- Landry, M., Gagnon, Y., 2015. Energy storage: technology applications and policy options. *Energy Procedia* 79, 315–320.
- Levelized cost and levelized avoided Cost of New Generation Resources in the Annual Energy Outlook 2019, Feb. 2019. International Energy Agency (IEA) [Online]. Available: https://www.eia.gov/outlooks/aeo/pdf/electricity_generation.pdf.
- Li, C., Zhou, H., Li, J., Dong, Z., 2020. Economic dispatching strategy of distributed energy storage for deferring substation expansion in the distribution network with distributed generation and electric vehicle. *J. Clean. Prod.* 119862.
- Locatelli, G., Mancini, M., 2010. Small–medium sized nuclear coal and gas power plant: a probabilistic analysis of their financial performances and influence of CO₂ cost. *Energy Pol.* 38 (10), 6360–6374.
- Locatelli, G., Bingham, C., Mancini, M., 2014. Small modular reactors: a comprehensive overview of their economics and strategic aspects. *Prog. Nucl. Energy* 73, 75–85.
- Locatelli, G., Boarin, S., Pellegrino, F., Ricotti, M.E., 2015. Load following with Small Modular Reactors (SMR): a real options analysis. *Energy* 80, 41–54.
- Locatelli, G., Boarin, S., Fiordaliso, A., Ricotti, M.E., 2018. Load following of Small Modular Reactors (SMR) by cogeneration of hydrogen: a techno-economic analysis. *Energy* 148, 494–505.
- Malheiro, A., Castro, P.M., Lima, R.M., Estanqueiro, A., 2015. Integrated sizing and scheduling of wind/PV/diesel/battery isolated systems. *Renew. Energy* 83, 646–657.
- Mignacca, B., Locatelli, G., 2020. Economics and finance of Small Modular Reactors: a systematic review and research agenda. *Renew. Sustain. Energy Rev.* 118, 109519.
- Mignacca, B., Locatelli, G., Sainati, T., 2020. Deeds not words: barriers and remedies for small modular nuclear reactors. *Energy* 118137.
- Mitchell, C., 2000. The England and Wales non-fossil fuel obligation: history and lessons. *Annu. Rev. Energy Environ.* 25 (1), 285–312.
- Mundada, A.S., Shah, K.K., Pearce, J., 2016. Levelized cost of electricity for solar photovoltaic, battery and cogen hybrid systems. *Renew. Sustain. Energy Rev.* 57, 692–703.
- N2EX day ahead auction prices. NORDPOOL [Online]. Available: <https://www.nordpoolgroup.com/Market-data/1/GB/Auction-prices/UK/Hourly/?view=table>.
- Oliva H, S., Passey, R., Abdullah, M.A., 2019. A semi-empirical financial assessment of combining residential photovoltaics, energy efficiency and battery storage systems. *Renew. Sustain. Energy Rev.* 105, 206–214.
- Policy paper Contracts for Difference, Jan. 2019. Department for Business, Energy & Industrial Strategy [Online]. Available: <https://www.gov.uk/government/publications/contracts-for-difference/contract-for-difference>.
- Proposals for further amendments to the Capacity Market, May 2019. Department for Business, Energy & Industrial Strategy, UK [Online]. Available: https://assets.publishing.service.gov.uk/government/uploads/system/uploads/attachment_data/file/805554/capacity-market-further-amends-consultation-response-2019.pdf.
- Roberts, T., Clark, H., Nuclear Electricity in the UK," Gov.UK [Online]. Available: https://assets.publishing.service.gov.uk/government/uploads/system/uploads/attachment_data/file/789655/Nuclear_electricity_in_the_UK.pdf.
- Safdarian, F., Gharehpetian, G., Ardehali, M., Poursistani, M., Shafiee, M., 2014. Comparison of effect of energy prices in Iran and USA on short-term planning of an industrial microgrid. In: International Conference and Project Meeting on Advanced Science and Technologies for Sustainable Development in Iran.
- Sainati, T., Locatelli, G., Smith, N., 2019. Project financing in nuclear new build, why not? The legal and regulatory barriers. *Energy Pol.* 129, 111–119.
- Sainati, T., Locatelli, G., Smith, N., Brookes, N., Olver, G., 2020. Types and functions of special purpose vehicles in infrastructure megaprojects. *Int. J. Proj. Manag.* 38 (5), 243–255.
- Saviuc, I., Peremans, H., Van Passel, S., Milis, K., 2019. Economic performance of using batteries in european residential microgrids under the net-metering scheme. *Energies* 12 (1), 165.
- Short Term Operating Reserve (STOR)," Nat. Grid, [Online]. Available: <https://www.nationalgrideso.com/balancing-services/reserve-services/short-term-operating-reserve-stor>.
- Strike price adjustment guidance version 2., July 2018. Low Carbon Contracts Company [Online]. Available: <https://www.lowcarboncontracts.uk/sites/default/files/Strike%20Price%20Adjustment%20guide%20final%20R.pdf>.
- Swanson, R.M., 2006. A vision for crystalline silicon photovoltaics. *Prog. Photovoltaics Res. Appl.* 14 (5), 443–453.
- The Capacity Market (amendment) Rules 2018, July. 2018. Office of Gas and Electricity Markets (Ofgem) [Online]. Available: https://www.ofgem.gov.uk/system/files/docs/2018/07/the_capacity_market_amendment_rules_2018_-_presented_to_parliament.pdf.
- The CFD scheme. Low Carbon Contracts Company, Electricity Settlements Company [Online]. Available: <https://www.lowcarboncontracts.uk/the-cfd-scheme>.
- Third part and industry charges," Npower Limited [Online]. Available: <https://www.npower.com/business-solutions/your-account/billing/charges/>.
- Upgrading our energy system: Smart Systems and Flexibility Plan," HM Government and Ofgem [Online]. Available: https://assets.publishing.service.gov.uk/government/uploads/system/uploads/attachment_data/file/633442/upgrading-our-energy-system-july-2017.pdf.
- Wang, D., Gao, X., Meng, K., Qiu, J., Lai, L.L., Gao, S., 2018. Utilisation of kinetic energy from wind turbine for grid connections: a review paper. *IET Renew. Power Gener.* 12 (6), 615–624.
- Waters, L., Spry, W., Chapter 6 Renewable Sources of Energy," Department for Business, Energy & Industrial Strategy, Energy Statistics Team [Online]. Available: https://assets.publishing.service.gov.uk/government/uploads/system/uploads/attachment_data/file/904823/DUKES_2020_Chapter_6.pdf.
- Winfield, M., Shokrzadeh, S., Jones, A., 2018. Energy policy regime change and advanced energy storage: a comparative analysis. *Energy Pol.* 115, 572–583.
- Xia, S., Chan, K., Luo, X., Bu, S., Ding, Z., Zhou, B., 2018. Optimal sizing of energy storage system and its cost-benefit analysis for power grid planning with intermittent wind generation. *Renew. Energy* 122, 472–486.
- Zhang, J., Leng, R., Chen, M., Tian, X., Zhang, N., 2020. The future role of nuclear power in the coal dominated power system: the case of Shandong. *J. Clean. Prod.* 256, 120744.