

INTERNATIONAL UNION OF PURE AND APPLIED CHEMISTRY

ANALYTICAL CHEMISTRY DIVISION*

COUNTERCURRENT CHROMATOGRAPHY IN ANALYTICAL CHEMISTRY

(IUPAC Technical Report)

Prepared for publication by

ALAIN BERTHOD¹, TATYANA MARYUTINA², BORIS SPIVAKOV^{2,‡}, OLEG SHPIGUN³,
AND IAN A. SUTHERLAND⁴

¹Analytical Sciences Laboratory, University of Lyon, CNRS, Bat. CPE, 69622 Villeurbanne, France;

²Vernadskii Institute of Geochemistry and Analytical Chemistry, Russian Academy of Sciences,
Kosygin str., 19, 119991 Moscow, Russia; ³Lomonosov Moscow State University, GSP-2,
Leninskie Gory, 119992 Moscow, Russia; ⁴Brunel Institute for Bioengineering, Brunel University,
Uxbridge, Middlesex UB8 3PH, UK

*Membership of the Division Committee during the final preparation of this report (2008–2009) was as follows:

President: A. Fajgelj (Slovenia); **Titular Members:** M. Camões (Portugal); Z. Chai (China); P. De Bièvre (Belgium); B. Hibbert (Australia); J. Labuda (Slovakia); R. Lobinski (France); W. Lund (Norway); Z. Mester (Canada); S. Motomizu (Japan); **Associate Members:** P. De Zorzi (Italy); A. Felinger (Hungary); M. Jarosz (Poland); D. E. Knox (USA); P. Minkinen (Finland); J. Pingarón (Spain); **National Representatives:** S. K. Aggarwal (India); R. Apak (Turkey); M. S. Iqbal (Pakistan); H. Kim (Korea); T. Maryutina (Russia); R. M. Smith (UK); N. Trendafilova (Bulgaria); **Provisional Member:** N. Torto (Botswana).

‡Corresponding author: E-mail: spivakov@geokhi.ru

Republication or reproduction of this report or its storage and/or dissemination by electronic means is permitted without the need for formal IUPAC permission on condition that an acknowledgment, with full reference to the source, along with use of the copyright symbol ©, the name IUPAC, and the year of publication, are prominently visible. Publication of a translation into another language is subject to the additional condition of prior approval from the relevant IUPAC National Adhering Organization.

Countercurrent chromatography in analytical chemistry

(IUPAC Technical Report)

Abstract: Countercurrent chromatography (CCC) is a generic term covering all forms of liquid–liquid chromatography that use a support-free liquid stationary phase held in place by a simple centrifugal or complex centrifugal force field. Biphasic liquid systems are used with one liquid phase being the stationary phase and the other being the mobile phase. Although initiated almost 30 years ago, CCC lacked reliable columns. This is changing now, and the newly designed centrifuges appearing on the market make excellent CCC columns. This review focuses on the advantages of a liquid stationary phase and addresses the chromatographic theory of CCC. The main difference with classical liquid chromatography (LC) is the variable volume of the stationary phase. There are mainly two different ways to obtain a liquid stationary phase using centrifugal forces, the hydrostatic way and the hydrodynamic way. These two kinds of CCC columns are described and compared. The reported applications of CCC in analytical chemistry and comparison with other separation and enrichment methods show that the technique can be successfully used in the analysis of plants and other natural products, for the separation of biochemicals and pharmaceuticals, for the separation of alkaloids from medical herbs, in food analysis, etc. On the basis of the studies of the last two decades, recommendations are also given for the application of CCC in trace inorganic analysis and in radioanalytical chemistry.

Keywords: countercurrent chromatography; liquid–liquid chromatography; liquid stationary phase; trace inorganic analysis; radioanalytical chemistry; IUPAC Analytical Chemistry Division.

INTRODUCTION

Countercurrent chromatography (CCC) is a liquid chromatography (LC) technique that uses two immiscible liquid phases without any solid support. As an LC technique, CCC uses many terms already defined for chromatography [1]. This article will give the fundamentals of the CCC technique and briefly describe the special chromatographic columns capable of maintaining a static liquid phase using centrifugal fields. A rapid approach to selecting solvent systems that can be used in CCC is given. Applications of CCC will be presented to show the interest and originality of the technique in analytical chemistry.

DESCRIPTION OF THE COUNTERCURRENT CHROMATOGRAPHY TECHNIQUE

It could be argued that the very name of the technique, countercurrent chromatography, is inappropriate since the two liquid phases do not flow countercurrent to each other. CCC is an LC technique with a support-free liquid stationary phase [2]. The inventor of the technique, Yoichiro Ito, named it after the countercurrent partition method of Craig that also used partitioning between two liquid phases to separate solutes [3]. The naming of the technique and the convenient CCC acronym were adopted by its users and cannot be changed now owing to the impressive number of publications dealing with it [3–9], although support-free LC might be an alternative name.

The major challenge of CCC is to obtain a stable support-free liquid stationary phase. The CCC column cannot be a simple tube with frits at the ends as in other LC techniques. In all modern CCC “columns”, centrifugal fields are used to hold the liquid stationary phase in place while the liquid mobile phase is pushed through it. Centrifugal fields imply rotating parts, rotors, gears, spools, rotating seals, motors, and speed regulators. Yet, the whole CCC machine is just a chromatographic column.

Advantages of a support-free liquid stationary phase

Versatility

In CCC, either phase can be the mobile phase. In fact, the mobile phase can be changed during a run if the components of the injected sample are retained for too long in the column. At least two immiscible solvents, e.g., water and octan-1-ol, heptane, or chloroform are required. Typical phase systems for organic separations can include as many as three, four, or more solvents. Phase diagrams can help an operator design the biphasic liquid system best suited for a particular application.

Unique possibilities

The main drawback of a liquid stationary phase is that it is a liquid. There is no problem in keeping a solid stationary phase inside a column. However, it is difficult to maintain the liquid stationary phase steady while another liquid, the mobile phase, is pushed through it. The earth’s gravitational field was used in the Craig machine and simple droplet CCC devices. However, this low field required low mobile phase flow rates, resulting in experiments lasting for days. Stronger fields were needed, and all modern CCC columns have rotating parts, rotors, gears, etc. to create a strong and efficient centrifugal field to effectively hold a large volume of the liquid stationary phase quasi-stationary against the flow of the mobile phase.

The huge choice of solvent combinations to make biphasic liquid systems can be an advantage (i.e., more choice) but also a disadvantage—it can be time-consuming to make the right choice, particularly if you do not know how to choose. It should always be kept in mind that any composition change made in one liquid phase may induce a change in the other liquid phase, which makes gradient elution in CCC less straightforward than in classical LC.

In CCC, the availability of the stationary phase for separated components is determined by the diffusion processes in liquids and efficiency of phase mixing (governed by the design parameters of columns, operational hydrodynamic conditions, and physicochemical properties of a two-phase liquid system). CCC gives a unique ability for the dynamic phase mixing of a two-phase liquid system during a chromatographic run. The use of silica as the backbone material for stationary phase in high-performance liquid chromatography (HPLC) limits the mobile-phase pH to the 2–8 range. Acidic mobile phases could cleave the organic bonded moiety; basic ones could dissolve the silica, although modern and expensive HPLC stationary phases can work with pH 1 and/or pH 10 mobile phases [10]. In contrast, if the solvents used to make the biphasic liquid system are not sensitive to pH, there are no additional pH problems as the material most frequently used in CCC columns is Teflon.

Strong solute–stationary-phase interactions can be detrimental for biological materials in HPLC. In contrast, liquid–liquid partitioning is the only interaction responsible for solute retention in CCC, and this partitioning can be very gentle for molecules and preserve biological activity.

Solutes can make use of the very high volume of stationary phase

CCC is definitively a very good preparative separation technique [11] as an important advantage of the liquid nature of the stationary phase is loadability. The injected material can dissolve in the whole stationary-phase volume. Liquid–liquid adsorption isotherms present a larger linear range compared to liquid–solid isotherms. Stationary-phase overload is less of a problem in CCC than in regular HPLC due to the high volume of stationary phase—often as high as 90 % of the total column volume. Nevertheless, this feature of CCC may be useful for analytical chemistry if the technique is applied to preparing standard reference materials.

Simple mechanism

The liquid–liquid partition ratio (K_D) of the solute in the biphasic liquid system used to perform the CCC separation is the only parameter in the retention equation

$$V_R = V_M + K_D V_S \quad (1)$$

where V_M and V_S are the mobile- and stationary-phase volumes, respectively, inside the CCC apparatus. V_M corresponds to the hold-up volume in HPLC [3]. The partition ratio K_D or partition coefficient of the solute (if only one solute form is involved) is the ratio of the solute concentration in the stationary phase over the solute concentration in the mobile phase. For example, for non-ionizable solutes, if the stationary phase is octan-1-ol and the mobile phase is water, K_D is the octan-1-ol/water partition coefficient [12].

Since there is no solid support, the column volume V_C is

$$V_C = V_M + V_S \quad (2)$$

The column volume is always known, either given by the manufacturer or measured. Equation 1 can be written as

$$V_R = V_C + (K_D - 1)V_S \quad (3)$$

showing that, beside solute partitioning between the two liquid phases, V_S is the only parameter acting on solute retention.

Chromatographic theory

Chromatographic parameters

Most of the classical equations used for LC are applicable in CCC. They are briefly recalled here, pointing out the specificity of the liquid stationary phase.

Equations 1 or 3 give the solute retention volume. All LC parameters can be used in CCC expressing their values using V_S , the liquid stationary phase volume [1,11]. The *retention factor* is expressed as

$$k = (V_R - V_M)/V_M = K_D V_S/V_M \quad (4)$$

The *separation factor* is used to compare the retention factors of two different peaks, 1 and 2

$$\alpha = k_2/k_1 = K_{D_2}/K_{D_1} \quad (5)$$

The *peak resolution* measures the quality of the separation. It is expressed as the ratio of the peak retention volume difference over the average peak width, w_b , at base

$$R_S = (V_{R2} - V_{R1})/[1/2 (w_{b1} + w_{b2})] \quad (6)$$

The chromatographic efficiency can be expressed using N , the *theoretical plate number* as

$$N = 16 (V_R/w_b)^2 \quad (7)$$

Combining the equations, it can be established that the peak resolution equation in CCC is

$$R_S = \frac{\sqrt{N}}{4} \frac{(K_{D_2} - K_{D_1})}{\left[\frac{V_M}{V_S} + \frac{(K_{D_2} + K_{D_1})}{2} \right]} \quad (8)$$

Equation 8 is valid for all chromatographic techniques. It is not used commonly because the mobile- and stationary-phase volumes are constant. It will be shown that this is not true in CCC where V_M and V_S are not constant and should be determined for all chromatograms.

Variable stationary-phase volume

The unique feature of CCC is that the volume of stationary phase is not constant. This is obviously due to the liquid nature of the stationary phase. The IUPAC nomenclature for chromatography defines the phase ratio, β , as the mobile-phase volume, V_M , divided by the stationary-phase volume, V_S [1]. In all chromatography techniques, except CCC, these volumes and so the β parameter are constants. Furthermore, the volumes V_M and V_S are not necessarily linked by eq. 2 as they are in CCC. For these reasons, it was necessary to introduce S_F , the *stationary-phase volume retention ratio* or *stationary-phase fraction*, defined as the ratio of the liquid stationary-phase volume over the column volume

$$S_F = V_S/V_C \quad (9)$$

The S_F parameter expresses the volume ratio of the CCC column that is occupied by the stationary phase. As a dimensionless parameter, S_F allows the comparison of stationary-phase retention capabilities of different CCC apparatuses. S_F is often expressed as a percentage. Equation 10 is eq. 8 rewritten using the S_F stationary-phase fraction

$$R_S = S_F \frac{\sqrt{N}}{4} \frac{(K_{D_2} - K_{D_1})}{\left\{ 1 - S_F \left[1 - \frac{K_{D_2} + K_{D_1}}{2} \right] \right\}} \quad (10)$$

Figure 1 and eq. 10 illustrate the critical importance of S_F in CCC. All Fig. 1 chromatograms are performed with the same sample, separated with the same CCC column and the same liquid composition of phases. The amount of liquid stationary phase present in the CCC column is the only changing parameter. If the amount of stationary phase retained in the CCC column decreases, the chromatographic peak resolution decreases, producing the dramatically different chromatograms of Fig. 1. Equation 8 shows that the stationary-phase volume should be maximized to increase peak resolution. Equations 1 or 3 express the solute retention volumes that also critically depend on V_S , the volume of stationary phase. Of course, if there is no stationary phase retained in the CCC column, all solutes will elute at the $V_R = V_M$ volume that will also be V_C , the column volume. This can be seen in Fig. 1. As the S_F factor decreases, there is less stationary phase inside the column. Consequently, there is more mobile-phase volume (eq. 2). The solutes with partition constants, K_D , lower than unity, solutes 1 to 6 in Fig. 1, elute with increasing retention volumes (eq. 3). Solute 7, with $K_D = 1$, is not sensitive to S_F or V_S (eq. 3). It elutes at the column volume in all cases (Fig. 1, $V_C = 120$ mL, vertical dotted line) [2].

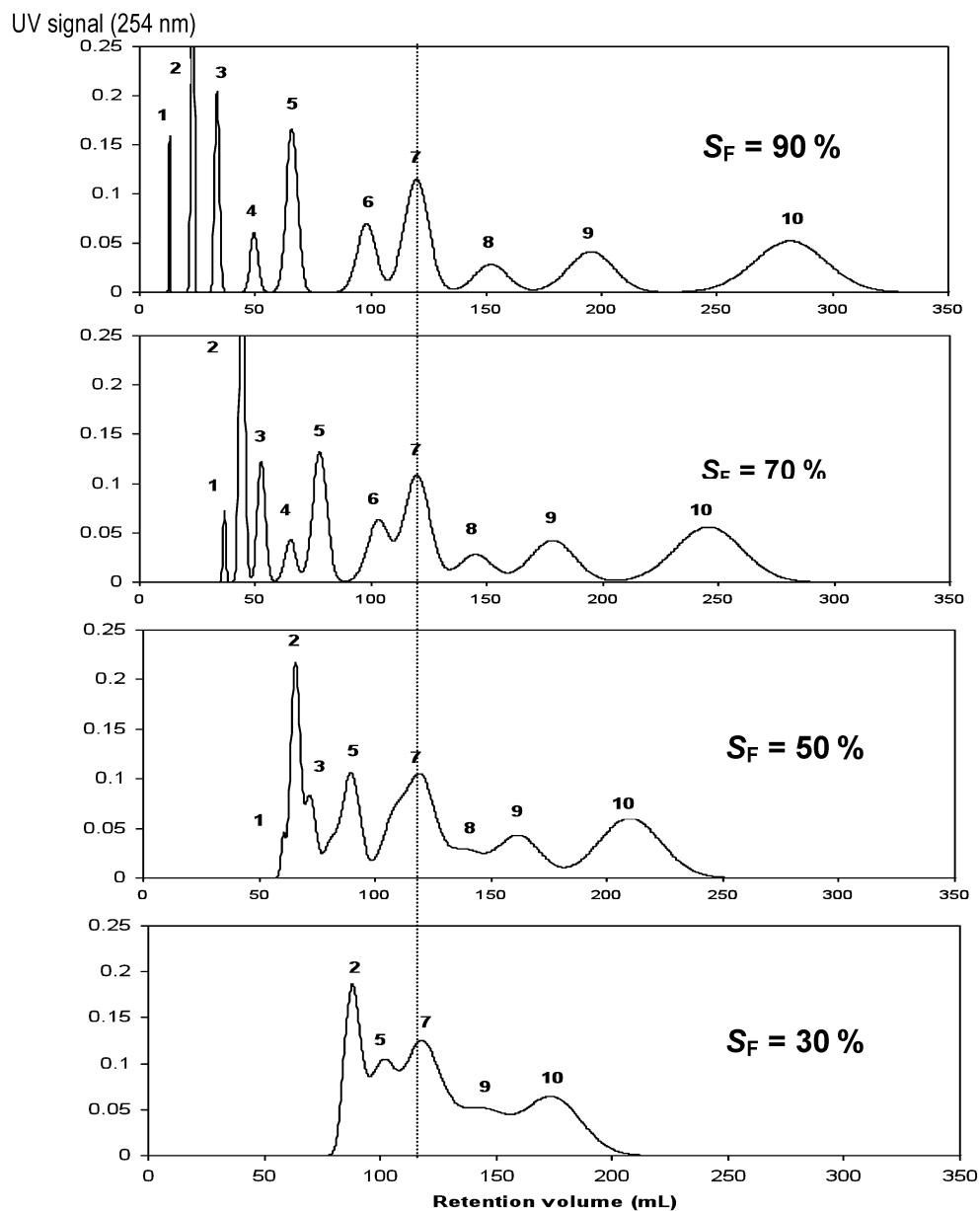

Fig. 1 Comparison of chromatograms obtained with the same hydrodynamic CCC column, the same biphasic liquid system, and the same sample containing 10 compounds. The volume of stationary phase retained decreased from 108 mL ($S_F = 90\%$) to 36 mL ($S_F = 30\%$). Column volume $V_C = 120$ mL (vertical dotted line), average efficiency 500 plates. Reprinted from [1] with permission by Elsevier.

CCC COLUMNS

From numerous column designs used to retain a liquid stationary phase [5–9], only two have had the potential for sustained commercial development. They are called the hydrostatic and the hydrodynamic configurations.

Hydrostatic CCC columns

The very first hydrostatic CCC columns used gravity to maintain the liquid stationary phase; they were called droplet CCC (DCCC) columns. They needed very long elution times (days). The DCCC columns are no longer in use today. Modern hydrostatic CCC columns are known and marketed under the name of centrifugal partition chromatographs (CPCs) [7]. Their two main characteristics are: (1) they have a single axis of rotation generating a constant centrifugal field and (2) they enclose geometrical volumes, tubes, channels, or locules that repeat themselves through connecting tubes forming a pattern (Fig. 2A). It can be seen that there is quite a significant volume of connecting ducts which only contain the mobile phase.

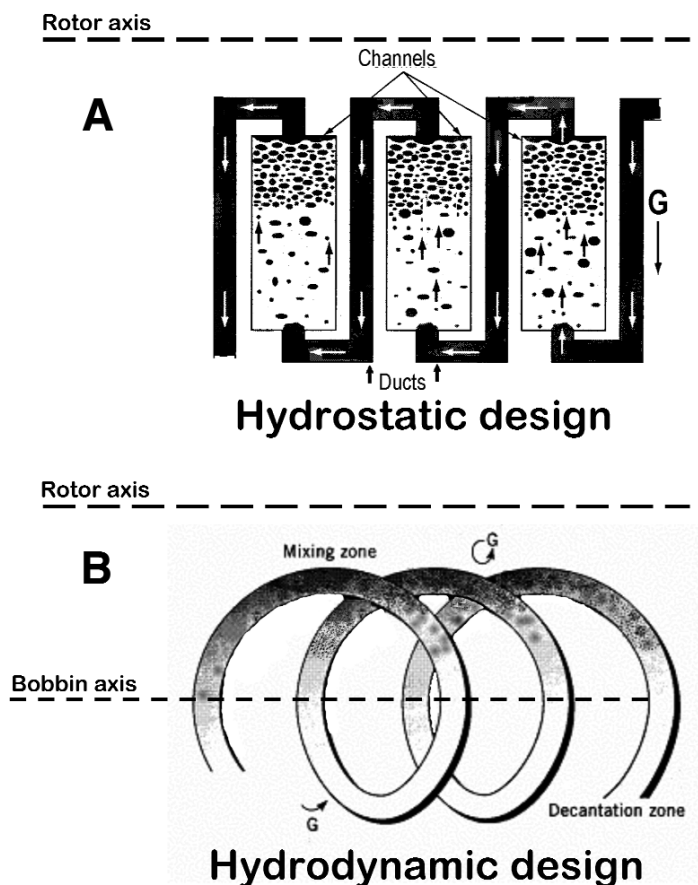

Fig. 2 Schematic view of the liquid motion in CCC columns. A – Hydrostatic columns or CPCs. There are a single axis of rotation producing constant centrifugal field (G) and no phase exchanges in the connecting ducts. B – Hydrodynamic columns. There are a variable and cyclic centrifugal field (G) produced by the planetary rotation of the bobbin around its own axis and the central rotor axis. There is contact between the two liquid phases throughout the tubing. The mobile phase is pictured in black, the stationary phase is white.

This design reduces the contact time for solute exchange with the stationary phase. It also builds a small hydrostatic pressure that explains the significant pressure drop needed to operate hydrostatic centrifuges. All hydrostatic centrifuges contain two rotary seals; one at the top and the other one at the bottom. They are quiet to operate.

In the toroidal coil CCC (helix CCC) system operated under a centrifugal force, the dimensions of the coil are reduced to that which is convenient for analytical separations. The coil is mounted around the periphery of the centrifugal bowl so that the stable radially acting centrifugal force field retains the stationary phase in one side of the coil as in the basic hydrostatic system described above.

Hydrodynamic CCC columns

Hydrodynamic centrifuges used in the CCC columns have two rotational axes, a main axis and a planetary one which generates a variable centrifugal force field. There can be any number of planetary axes but the most common are single, double, and triple axes. Each planetary axis has a bobbin or spool mounted on it that contains the coils of continuously wound Teflon tubing.

In hydrodynamic columns, it is important to know the ratio of the spool radius, r , over the rotor radius, R . This ratio was traditionally termed β [3–6]. Since β is defined in LC as the phase ratio V_S/V_M so the CCC *beta ratio* should be noted $\beta_r = r/R$ (see Fig. 3).

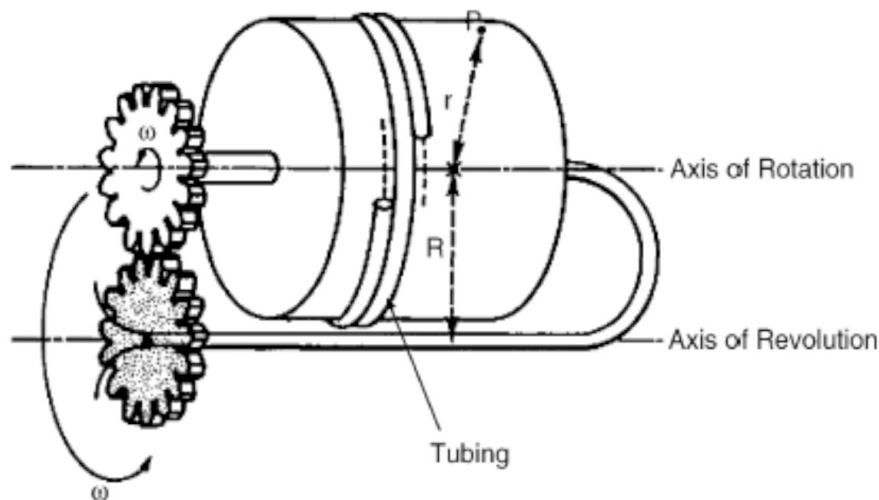

Fig. 3 Schematic drawing of the rotating coil in a hydrodynamic CCC instrument equipped with planetary gear. Reprinted from [4] with permission from Wiley.

The tubing can be connected from the outside of the centrifuge, wound round the bobbins, and passed back to the outside again without any rotary seals—hence, from the chromatography point of view it is equivalent to one long thin continuous column. The variable force field produces mixing and settling zones throughout the whole length of the coiled column as indicated in Fig. 2B. There is continuous contact between the two liquid phases throughout the column with no significant pressure build-up. Hydrodynamic centrifuges work with low mobile-phase pressure but can generate noise from the gear assembly, which can be reduced in well-designed centrifuges. These columns are often called high-speed CCC (HSCCC) columns since they can operate much more rapidly than the Craig, DCCC, and gravity-based columns.

Table 1 compares the features of the two kinds of CCC columns. It is not possible to say that one kind is clearly superior to the other. The best situation is to have both kinds of CCC column to cover all possible cases. Studies are going on to develop large-scale CCC centrifuges based on both types being able to produce significant mass of purified material (preparative CCC) [13–15]. Such centrifuges can be used to produce standard reference materials for analytical purposes and to purify analytical reagents.

Table 1 Comparison of the properties of hydrodynamic and hydrostatic columns.

Column	Hydrodynamic	Hydrostatic
Liquid retained in	Coiled Teflon tubes	Channels
Commercial name and acronym	Coil planet centrifuge, high-speed countercurrent chromatograph, HSCCC	Centrifugal partition chromatograph, CPC
Centrifugal field	Variable, two axes of rotation	Constant, one axis of rotation
Stationary-phase retention	Variable	Good
Efficiency	Up to 4 plates per tube turn	Up to 1 plate per channel
Pressure	Low, 0.1–10 kg/cm ²	Medium, 2–70 kg/cm ²
Maintenance	Connecting tubing to change every ~100 h	Rotating seals to lubricate every ~100 h
Other	Possible noisy gear assembly, quieter centrifuge with belt drive	Quiet centrifuge

There are so-called cross-axis chromatographs which are *hydrodynamic* CCC columns containing two spools of coiled tube mounted in a rotor in such a way that the axis of rotation of the spools is at a right angle from the main axis of rotation.

Liquid motion in CCC columns

Hydrostatic CCC columns or CPCs

As pictured in Fig. 2, the liquid motion in the two kinds of CCC column is very different. It is relatively easy to understand that the liquid stationary phase will be physically retained in the channels of the hydrostatic columns. If the mobile phase flow rate is stopped, the two liquid phases stay where they are (hence the term hydrostatic). The way the mobile phase moves through the stationary phase depends on their relative density. In Fig. 2A, the black mobile phase is the lighter liquid (the upper phase in a test tube). It is illustrated entering the channel through the lower end and leaving at the top end—this is called *ascending mode* where the mobile phase rises through the retained denser stationary phase. The denser or lower liquid phase could be used as the mobile phase. In that case, it would enter in the channel from the top end and leave via the lower end—this is known as *descending mode* where the mobile denser phase descends through the lighter retained stationary phase [7]. In Fig. 2A, the mobile phase is shown breaking up into droplets. In practice, the mobile phase cascades through the stationary phase, bending in the direction of rotation due to the Coriolis effect, and produces its mixing spray or droplets when the cascade hits the chamber wall or the liquid interface.

Hydrodynamic CCC columns or HSCCC

Until recently, the reason why the liquid stationary phase is retained in hydrodynamic columns was not fully known. In rotating bobbins or spools with coiled tubes, the helix of the tube produces a force, called the *Archimedean screw force*, that pushes the contained liquids toward one end of the tube called the *head*, the higher-pressure end. The other end of the tube is called the *tail*—the lower-pressure end. When two immiscible liquids are present in the rotating coiled tube or column, the heavier liquid will move toward the tail end of the coil, displacing the lighter liquid toward the head end. The intensity and

direction of the Archimedean screw force depend on the rotational speed and the direction and helical pitch of the coiled tube [14].

As shown by Fig. 2B, when the lighter black liquid phase is entered through the tail of the rotating coil, it will go through the denser liquid in a succession of mixing and settling zones up to the head. The lighter phase moves in the *tail-to-head* direction through the denser phase. If the denser phase is the mobile phase, it should enter the CCC column through the head. This is called the *head-to-tail* direction through the lighter phase. If the mobile phase flow rate is stopped while the rotor is still spinning, the Archimedean screw force will move the lighter liquid phase toward the head end of the coil and the heavier phase toward the tail end of the coil. It is this respective movement of the phases that makes the process a hydrodynamic one. The stationary phase is held in equilibrium against the flow of the mobile phase. Increase this flow and more stationary phase is displaced from the column, resulting in lower stationary-phase retained volume (lower S_F).

SOLVENT SYSTEMS

Three criteria

Numerous two-phase solvent systems with a broad spectrum of polarity or containing extracting reagents can be applied to separate organic, bioorganic, and inorganic substances. Either the aqueous or organic phase of a two-phase liquid system can be used as the mobile phase. Numerous examples of solvent systems used in CCC can be found in the literature [5,15,16].

In general, solvent systems known from preparative CCC purifications can also be used at the analytical scale. The systems for inorganic separations are very different from those for organic separations, as in most cases the former contain a complexing or extracting reagent (a ligand) [17]. There are three important criteria for choosing a two-phase liquid system. First and obviously, it should form two immiscible phases. Second, the phase selected to be the stationary phase should be retained by the CCC column. Third, the sample should be separated by the two-phase liquid system selected.

Two immiscible phases

There are countless solvent mixtures that form two immiscible phases. When the nature of the organic substances to be separated is known, one may find a suitable solvent system by searching the literature for solvent systems that have been successfully applied to similar compounds [2–10]. In case of organic-aqueous two-phase systems, the organic phase consists of one solvent or of a mixture of different solvents. Various non-aqueous/non-aqueous solvent systems (e.g., heptane/acetonitrile) have been used for separation of nonpolar compounds and/or compounds that are unstable in aqueous solutions. Separation of macromolecules and cell particles can be performed with a variety of aqueous/aqueous polymer phase systems. Among the various polymer phase systems available, the following two types are the most versatile for performing CCC. The poly(ethylene oxide) (PEO)/potassium phosphate systems provide convenient means of adjusting the partition coefficients of macromolecules by changing the molecular mass of the selected PEO and/or altering the pH and/or concentration of the phosphate buffer. The PEO 6000/Dextran 500 systems provide a physiological environment, suitable for the separation of mammalian cells by optimizing osmolarity and pH with electrolytes [6].

For preconcentration and separation of inorganic species, a stationary phase containing extracting reagents of different types (cation-exchange, anion-exchange, and neutral) in an organic solvent is usually applied [2,18–25]. The mobile-phase components should not interfere with the subsequent analysis. Solutions of inorganic acids and their salts are most often used. The mobile phase may also contain specific complexing agents, which can bind one or several elements under separation.

Significant retention of the liquid stationary phase

The parameters responsible for a significant retention of the liquid stationary phase measured by the S_F parameter (eq. 9) depend on the CCC column itself by the tubing bore used to make the coil(s), the coil diameter, and the β ratio (see Fig. 3). It also depends on the experimental parameters: rotational speed and mobile-phase flow rate [14]. The physicochemical properties of the two-phase liquid system are also critically responsible for good liquid stationary-phase retention. The liquid-phase density difference, the mobile-phase viscosity, and interfacial tension are the three main liquid system parameters acting on the S_F ratio [23]. For example, the aqueous two-phase systems (ATPSs) made with PEO, potassium phosphate, and water are very difficult to retain in hydrodynamic columns due to a very low interfacial tension, high viscosity of the PEO upper phase, and low density difference. It is possible to work with ATPSs using hydrostatic columns. Also, the addition of extracting reagents and mineral salts to a two-phase system (in case of inorganic separations) can strongly affect the physicochemical properties of liquid systems and, consequently, their hydrodynamic behavior and S_F value.

Unique methods of using the liquid nature of the stationary phase

Three unique uses of the liquid nature of the stationary phase in CCC are presented below. In these three cases, the methods were developed because solutes were retained too long in the stationary phase. These ways of performing chromatographic separations would not be possible with the other chromatographic techniques working with a solid stationary phase.

Dual-mode method

Figure 4 shows a straightforward way to explain the dual-mode method. During step A, the CCC chromatograph is used as it would be for a classical separation. Solutes 1 and 2 elute as they have a low partition ratio. Solutes 3 and 4, with high partition ratio, have a high affinity for the stationary phase. They move very slowly inside the CCC “column”. Using the advantage of a liquid stationary phase, the role of the phases is switched after one column volume, V_C , of mobile phase has passed through the column.

During step B (Fig. 4), the new mobile phase is the liquid that was previously the stationary phase, and it is pumped in the opposite direction. Solute 4, which moved the slowest in step A (Fig. 4), is the closest to what is now the column outlet. Solutes 3 and 4 have a high affinity for what is now the mobile phase. Solute 4 is the first to leave the column followed by solute 3 (Fig. 4, bottom chromatogram). The solute elution order is 1, 2, 4, and 3.

The dual-mode method is very different from the back-flush method used in multidimensional gas chromatography (GC) or LC where the flowing direction of the mobile phase is changed. This decreases the peak resolution factor of solutes partly separated in the column. During step B of the CCC dual-mode method, it is the previous stationary phase that moves backward. This increases the peak resolution factor of solutes inside the column.

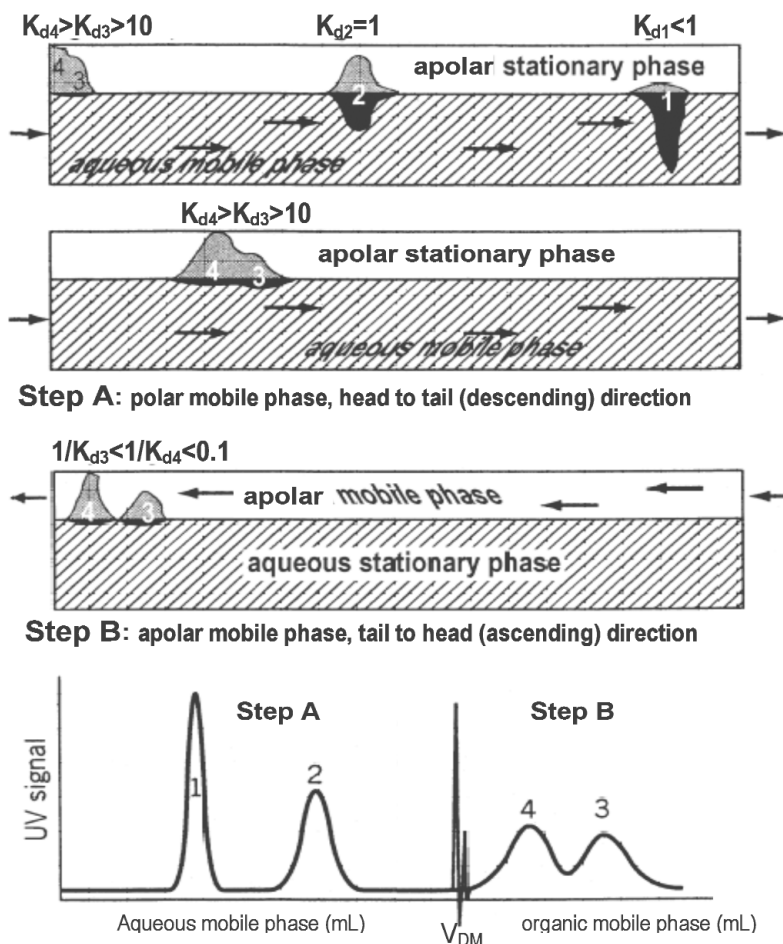

Fig. 4 Schematic view of a dual-mode separation of four compounds with widely differing polarities: V_{DM} is the aqueous phase volume after which the phase role was switched. The dual-mode way is possible with both types of CCC columns. Reprinted from [2] with permission from Elsevier.

Concurrent CCC

Concurrent CCC is another solution to force the highly retained solutes to elute out of the column [24]. In concurrent CCC, two pumps are used. The liquid stationary phase is slowly pushed in the same direction as the mobile phase. Most often, the “stationary” phase flow rate is less than 1 % of the mobile-phase flow rate. This method was used to measure very large octan-1-ol-water partition constants using an aqueous mobile phase and a slow-motion octan-1-ol stationary phase. The $K_{Do/w}$ constant was expressed as [2]

$$K_D = (t_R F_{aq} - V_{M,aq}) / (V_{S,oct} - t_R F_{oct}) \quad (11)$$

In eq. 11, $V_{M,aq}$ is the volume of aqueous phase contained in the CCC “column” and $V_{S,oct}$ is the volume of “stationary” octan-1-ol phase, F_{aq} and F_{oct} were, respectively, the flow rate of the aqueous and octan-1-ol phases, with $F_{oct} \ll F_{aq}$, and t_R is the retention time of the solute.

Elution-extrusion method

Another way to recover a solute having a strong affinity for the liquid stationary phase is to extrude the whole of the column contents after the centrifuge has stopped following the elution of one column vol-

ume, V_C [25]. It has been found that the main part of band broadening occurred when the solutes left the column in the mobile phase. Inside the column, where the two liquid phases are in contact with each other, the peaks are thin. Extruding the two phases contained in the column maintains thin peaks and produces surprisingly high peak resolution factors [25].

Table 2 compares the retention volumes of the six compounds of a mixture separated in the eight possible CCC ways with the same biphasic liquid system and CCC column. The classical use of CCC in the reversed-phase (RP) mode (apolar liquid as the stationary phase) separates at baseline all six compounds needing a large volume of mobile phase to elute compound 6. The first idea to save time and solvent is to work using the normal-phase (NP) mode with the polar liquid used as the stationary phase. In this liquid configuration, the partition ratios K'_D are still the ratio of the solute concentration in the stationary phase over that in the mobile phase. So K'_D (normal phase) is the inverse of K_D (reversed phase) and the elution order is reversed. Table 2 shows that the best method to select will depend on which compound is most desired. All methods use 4–10 times less solvent than the classical method.

Table 2 Comparison of the retention volumes and peak resolution factors obtained in the separation of the same mixture using the eight possible CCC operation methods.

RP mode (apolar liquid stationary phase, polar mobile phase)													
Compound	K_D	Classical mode		Dual mode		Elution–extrusion mode			Concurrent mode				
		V_R /mL	R_s	V_R /mL	Variation	R_s	V_R /mL	Variation	R_s	V_R /mL	Variation	R_s	
1	0.2	40		40	0 %		40	0 %		43.1	+8 %		
2	0.8	100	3.71	100	0 %	3.71	100	0 %	3.71	101.8	+3 %	3.51	
3	2	220	3.25	195	–11 %	1.80	179	–19 %	3.56	201.7	–8 %	2.85	
4	6	620	4.12	151.7	–75 %	0.70	224.8	–64 %	2.69	426.2	–31 %	3.10	
5	12	1220	2.82	140.8	–88 %	0.50	237.2	–80 %	1.14	610	–50 %	1.54	
6	24	2420	2.86	135.4	–94 %	2.20	243.6	–90 %	0.82	782.9	–68 %	1.08	

NP mode (polar liquid stationary phase, apolar mobile phase)													
Compound	K_D	Classical mode		Dual mode		Elution–extrusion mode			Concurrent mode				
		V_R /mL	R_s	V_R /mL	Variation	R_s	V_R /mL	Variation	R_s	V_R /mL	Variation	R_s	
6	0.042	24.2		24.2	0 %		24.2	0 %		26.5	+10 %		
5	0.083	28.3	0.69	28.3	0 %	0.69	28.3	0 %	0.69	30.9	+9 %	0.67	
4	0.167	36.7	1.11	36.7	0 %	1.11	36.7	0 %	1.11	39.7	+8 %	1.08	
3	0.5	70.0	2.71	150	+53 %	2.14	84.3	+19 %	2.99	73.3	+5 %	2.58	
2	1.25	145.0	3.02	90	–38 %	1.71	128.6	–13 %	2.23	141.8	–2 %	2.76	
1	5	520.0	4.88	60	–88 %	2.26	158.5	–69 %	2.40	381.3	–27 %	3.97	

Column volume, $V_C = 120$ mL. Stationary-phase volume, $V_S = 100$ mL, $S_F = 83$ %.

K_D in the RP mode becomes $1/K_D$ in the NP mode. Both are dimensionless.

Variation: change in retention volume expressed as percentage compared to the classical elution mode.

V_R , classical mode, is expressed by eqs. 1 or 3. Variations are computed using this volume as a reference.

V_R , dual mode is expressed as $V_{CM}(1 + 1/K_D)$ with the volume of elution in classical mode, $V_{CM} = 130$ mL [7].

V_R , elution–extrusion and concurrent modes were expressed using the equations listed in refs. [6,7]. The flow rate of the “stationary phase” was 10 % of that of the mobile phase in concurrent mode [6].

Optimum separation conditions

It was demonstrated that the best conditions for optimum separation were a good retention of the stationary phase (Fig. 1) and solutes having partition ratio K_D between 0.5 and 2 [26]. Changing the liquid system composition changes the solute partition ratios and hence the chromatographic selectivity and peak resolution. The originality of CCC is that in many cases both the mobile- and stationary-phase compositions are related. Altering one changes the composition of the other. Ternary-phase diagrams

are often used to predict the two-phase compositions [2,7,9]. Highly retained solutes can always be eluted using the liquid nature of the stationary phase. In some limited cases, step gradient can also be used [16].

For organic separations, two liquid-phase systems obtained with the quaternary solvent system made by mixing heptane, ethyl acetate, methanol, and water were found to be extremely useful in CCC. Mixtures can go from very apolar (heptane/methanol system) to very polar (ethyl acetate/water system) with a wide possibility of modulation adding more or less polar (methanol) or apolar (heptane) solvent [27,28].

The partition of inorganic compounds, as well as organic ones, is dependent on the properties of the system used, partition coefficients of substances to be separated, and parameters of the planetary centrifuge operation such as rotation and revolution speeds, direction and speed of the mobile-phase pumping, internal diameter of the column, and sample volume. Because inorganic ions are usually extracted as their complex compounds, the complexation process, its rate and mass transfer rate are among the main factors that determine the separation efficiency. The kinetics is of particular importance as CCC separation can be a nonequilibrium process [22,29–31].

APPLICATIONS

CCC is playing an increasingly important role in separation science. All components in the sample solution injected into the column can be recovered, and irreversible adsorption and contamination of samples can be virtually eliminated. A crude sample can be injected directly into the column, which simplifies sample preparation. Now CCC is successfully used for the separation of organic and inorganic substances from a complicated mixture.

Organic substances

CCC has become a method of choice in natural products chemistry and has made possible the separation of a number of biologically interesting natural products that are difficult or impossible to separate by other techniques [2,16,30]. Crude extracts of plants or other organisms are often too complex for the direct analysis by HPLC. Certain materials may irreversibly bind to the packing material or may plug the column inlet filters, and hence reduce the column life. Those restrictions do not apply to analytical CCC, which represents an interesting method for enrichment and separation of various analytes.

The technique is also used for the separation of biochemicals and pharmaceuticals. CCC is especially suitable for the separation of alkaloids from medical herbs using simple solvent systems, for the total hormonal analysis of natural samples [31], and for the screening of new bioactive compounds in crude extracts and other complex samples [32]. CCC has been also suggested as an alternative to the shake flask method to measure liquid–liquid partition coefficients as a way to characterize the lipophilic–hydrophilic nature of a compound [33].

Below, some interesting methods are briefly described which have been successfully used in the analysis of various samples or which can be applied to analytical purposes without serious modification of the procedures and apparatus.

Analysis of plant and different natural products

Different types of hydrodynamic (HSCCC, cross-axis coil) and hydrostatic (toroidal coil) centrifuges can be used for separation and concentration of various compounds from plant and different natural products. The quantity of separated compounds may range from trace to gram amounts.

1. Toroidal coil centrifuges

Toroidal coil centrifuges have been successfully applied to the separation and purification of plant hormones, namely, indole auxins, gibberellins, cytokinins, and abscisic acid. Indole auxins were separated by either hexane-ethyl acetate-methanol-water (volume ratio 0.6:1.4:1.0:1.0) or chloroform-acetic-

acid–water (2:2:1) in a column with a total capacity of 18 mL. The latter solvent system was especially useful for the separation of abscisic acid from indole-3-acetic acid. Gibberellins (GA₃, GA₄, and GA₇) were separated from each other in ether-methanol-phosphate buffer (pH 7) (3:1:2). The CCC method was suitable for the separation of four cytokinins in ethyl acetate-methanol-phosphate buffer (pH 7) (3:1:3) [2,4,5].

A toroidal coil planet centrifuge for analytical-scale separations was used for the purification of abscisic acid (ABA) obtained from crude plant extracts and its determination in several plant tissues using HPLC and GC-MS [34].

The results of the isolation of 3-oxo- Δ^5 -steroid isomerase (KSI) from crude *E. coli* lysate were published [35]. A separation was performed on ca. 3 mg of ¹⁵N-labeled KSI using a polymer-containing system based on PEO 3350. The present method eliminates sample loss and denaturation caused by the solid support and yields pure proteins in both preparative and analytical separations.

2. High-speed hydrodynamic centrifuges (HSCCC)

Numerous applications in the analysis and preparation of natural products by CCC have been reported [1,36–38]. Separation of polyphenolic natural products such as flavonoids are difficult because these compounds tend to show “peak tailing” in RP-HPLC, as well as irreversible adsorption on silica gel. Those difficulties do not exist in CCC and are the reason why CCC has been recognized as a most valuable technique for the isolation of polyphenols [39]. The flavonoids and hydroxyanthraquinones can be easily separated by CCC with a high selectivity [40].

Zhang has published the results of the separation of alkaloids (from *Stephania tetrandra* S. Moore) using *n*-hexane–ethyl acetate–methanol–water systems at different volume ratios, hydroxyanthraquinones (from the rhizome of *Rheum palmatum* L.) using a system of hexane–ethyl acetate–methanol–water (9:1:5:5) and flavonoids (from sea buckthorn *Hippophae rhamnoides*) using a system of chloroform–methanol–water (4:3:2) by CCC; the total capacity of the column was 43 mL, the maximum revolution speed of centrifuge was 2000 rpm [40]. By increasing the flow-rate of the mobile phase in these analytical separations, the separation time for a crude sample mixture was shortened to within 15 min, which is quite comparable with that of analytical HPLC. Milligram and even gram amounts of substances can be isolated by the CCC technique. This makes it possible to produce standard reference materials for any analytical study.

For the more efficient separation of compounds having a wide range of polarity, lower and upper phases of the solvent system were used as the mobile phase in succession. This method achieved a complete separation of five components present in a 1-mg sample mixture. The peak fraction of each compound was subjected to mass spectrometric analysis for compound structure confirmation [41]. Figure 5 shows the countercurrent chromatogram of five major compounds in the crude extract of rhizome of *Rheum palmatum* L. Three peaks (1, 2, and 3) were eluted with the upper phase in NP mode followed by two peaks (A and B) which were eluted with the lower phase in RP mode. The results indicated that peaks A, B, 1, 2, and 3 were corresponding to chrysophanol, emodin, physcion, aloe-emodin, and rhein, respectively.

CCC was used for the systematic selection and optimization of a two-phase solvent system to separate alkaloids from *Coptis chinensis* Franch using a system of chloroform–methanol–HCl solution (0.3–0.1 mol/L) at different volume ratios [42]. One separation run yielded four pure alkaloids, including palmatine, berberine, epiberberine, and coptisine from a crude alkaloid extract.

Analytical application of CCC was successfully demonstrated for the separation of microgram quantities of flavonoids from a crude ethanol extract of sea buckthorn in a multilayer coil with a total capacity of 8 mL using a two-phase solvent system composed of chloroform–methanol–water (4:3:2) [43]. Five peaks, including isorhamnetin and quercetin, were well resolved and eluted within 8 min.

An artificial mixture of three (50 μ g each) common plant coumarins (herniarin, scopoletin, and umbelliferone) and one flavanone (hisperetin) was separated with a hydrodynamic CCC column connected to a photodiode array detector. The lower phase of a chloroform–methanol–water (volume ratio

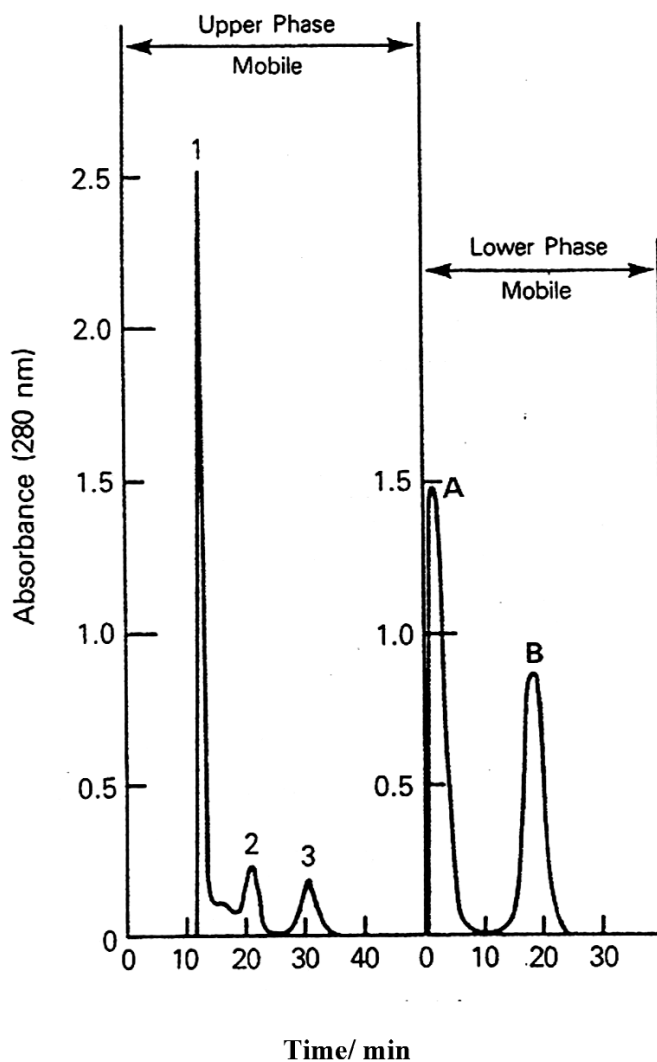

Fig. 5 Chromatogram of hydroxyanthraquinone derivatives from a crude extract of rhizome of *Rheum palmatum* L. Hydrodynamic CCC column. Solvent system: hexane–ethyl acetate–methanol–water (9:1:5:5). Reprinted from [42] with permission from Elsevier.

13:7:8) system was used as the mobile phase, and baseline peak resolution of the four compounds was achieved in less than 30 min [44,45].

Several flavonoids, including 7-*O*-glucosylbaicalein, baicalein, and chrysin, were separated from an ethyl acetate extract of the seeds of *Oroxylum indicum* (a herbal medicine) using a column of 27–50 mL total volume by two-phase solvent systems chloroform–methanol–water (8:10:5) [46] and hexane–ethyl acetate–methanol–water at various volume ratios [47]. All these constituents were identified and detected by NMR spectroscopy and electrospray ionization/mass spectrometry (ESI/MS) after isocratic or step-gradient elution. The separation of a flavonoid fraction from seeds of *Oroxylum indicum* (*Bignoniaceae*) was achieved in 6–20 min using a 4.6-mL (0.76 mm i.d. tubing) coil column [48].

The results of the isolation and purification of tanshinone IIA, tanshinone I, dihydrotanshinone I, and cryptotanshinone using HSCCC were published [49]. CCC was also successfully used for the sep-

aration of hydroxyanthraquinones from traditional Chinese medicines *Rheum officinale* Baill (Dahuang) and *Polygonum cuspidatum* Sieb. Et Zucc (Huzhang) [50,51].

Hydrodynamic CCC columns can be used for the separation of indole plant hormones [31,52], plant alkaloids [31], and s-triazine herbicides [53,54] and for the isolation of bioactive natural products [55]. Efficient analytical-scale separations were demonstrated for separations of indole plant hormones with a multilayer coil in centrifuges with the total capacity up to 10 mL in hexane–ethyl acetate–methanol–water (volume ratio 1:1:1:1) [31,56]. The systems hexane–ethyl acetate–methanol–water at different volume ratios were used for indole separation by HSCCC in a 40-mL column [57]. Four indole plant hormones were completely resolved but only within 90 min, which is slow for routine analytical applications.

However, it should be mentioned that bioactive ligands are often very similar in structure, and it is very difficult to obtain individual ligands in pure form for pharmacological evaluations. The complete separation of the bioactive lignans schisanhenol and its acetate in a multilayer coil column using an *n*-hexane–ethanol–water (6:5:5) system [62] is an example that demonstrates that HSCCC can be a complementary method to HPLC even if the separation is not rapid.

The separation of an artificial mixture of vincamine [58], the major alkaloid of *Vinca minor* (Apocynaceae) and vincine (11-methoxyvincamine), was performed on a centrifuge with a multilayer column (0.85 mm i.d.) using a hexane–ethanol–water (6:5:5) system. Comparison of the separation with results obtained by RP-HPLC showed that both methods gave good baseline peak resolution, but it was possible to obtain an additional peak of the vincine isomer, which was not resolved by HPLC.

CCC is used in flavor analysis for the separation of labile substances, such as aroma compounds or their respective precursors (polyols and glycoconjugates), from complex natural mixtures [59]. The application of a multilayer coil hydrodynamic CCC column to the analysis of reactive flavor precursors from *Rosa damascena* flowers was reported [60].

The versatility, resolving power of CCC, and its analytical capabilities have been demonstrated with some newly developed analytical high-speed planet centrifuge systems. Interfacing CCC with mass spectrometry was suggested by Oko in the 1980s. It provides an analytical methodology that integrates the advantages of CCC with the low detection limit and identification capability of mass spectrometry [61–64]. The capability of thermospray MS/CCC was demonstrated in identifying and validating the bioactive and structurally known lignans from a crude extract of *Schisandra rubiflora* (Rhed et Wils), a traditional Chinese herbal medicine for treatment of hepatitis [65]. The separation of indole auxins mixtures by HSCCC [63] was achieved within 20 min with excellent CCC theoretical plate numbers. The best separation efficiencies for indole-3-acetamide, indole-3-acetic acid, and indole-3-butyric acid were obtained on a small multilayer coil convenient for analytical studies (column of 0.3 mm i.d. and a capacity of 3–6 mL, rotated at 3500 rpm), using a hexane–ethyl acetate–methanol–water (1:1:1:1) system. CCC/MS was applied also to the determination of alkaloids, triterpenoic acids, mycinamicins, colistins, etc. [62]. Analytical CCC equipment can be directly interfaced to frit electron ionization (EI), chemical ionization (CI), and fast atom bombardment MS (FAB/MS) without an additional HPLC pump [62]. The CCC–frit/MS may become a useful tool for the investigation of natural products (especially for the separation of biologically important substances) and can be also successfully applied to structural characterization of natural products.

The capability and resolving power of CCC in the separation of a few natural product mixtures (erythromycins and didemnins) combined with ESI/MS has been demonstrated [66]. Application of this CCC/ESI/MS system is illustrated by the separation and detection of biologically important compounds. Five polar herbicides were separated and characterized using an online CCC/ESI/MS combination [67]. A standard isocratic biphasic solvent system of *n*-hexane–ethyl acetate–methanol–water was used. The chromatograph was coupled to a triple quadrupole mass spectrometer via ESI/MS, enabling mass spectra to be obtained in negative ion mode of each compound. Limits of detection are reported for this series of compounds along with representative negative ion ESI/MS data and calibrations for the separation. CCC can be successfully interfaced directly to ESI/MS without any major modifi-

cations to conventional HPLC/MS interfaces. On-line CCC/ESI/MS and APCI/MS methods were also used for the identification of flavanoids using a hexane–ethyl acetate–methanol–water system [68].

Food analysis

CCC has the potential to play an important role in food analysis because it permits the analysis of crude and complex samples. One of the main advantages of CCC is that it can separate substances from large volumes of such samples, which is important for food analysis. This potential has not yet been recognized in the area of food testing. Eventually, combining CCC separation with other analytical identification and detection methods, such as mass spectrometry, capillary electrophoresis, or HPLC, is potentially useful for toxin analysis in food [69].

One of the most frequent diseases is gastroenteritis resulting from food contaminated with *Staphylococcal enterotoxin A* (SEA) produced by the bacterium *Staphylococcus aureus*. CCC was evaluated for SEA separation from milk [70]. Milk samples containing SEA were separated on a toroidal coil column with a total capacity of 13 mL. The polymer phase system, composed of PEO 1000 and dipotassium phosphate, was used as a stationary phase.

CCC was used for the separation of both native and heat-denatured SEA contained in crude samples of mushrooms in a column with a total capacity of 18 mL [71]. This simple method does not require any sample preparation beyond homogenization. The method is approximately 10 times more sensitive than immunological methods such as western blotting because very large samples can be applied in CCC.

CCC was applied to the analysis of phosphocholine-containing glycolipids (GGPL-I and GGPL-III) of *Mycoplasma fermentans*, which is thought to be one of the causative microorganisms of rheumatoid arthritis (RA) [72]. The CCC method is a powerful tool for the separation of lipids of microorganisms and, more importantly, it may become a useful tool for the analysis of a host–pathogen interaction or, in other words, a lipid–protein interaction at lipid microdomains.

Hydrodynamic CCC columns were used to separate monomers, dimers, trimers, and oligomers of catechin and/or epicatechin from apple procyanidins (condensed tannins) [73]. The pharmacological properties of procyanidins (beneficial effect on the circulatory system, anti-allergy and antibiotic activities, etc.) depend on the degree of their polymerization, which makes it necessary to establish a reliable separation method. NP, RP, and size-exclusion LC tend to cause irreversible adsorption of procyanidins onto the column packing materials, whereas no losses were observed with the CCC separation [74].

Furthermore, several food-related polyphenols, such as condensed catechin oligomers (procyanidins), phenolic acids, and flavonol glycosides were clearly separated under the same HSCCC condition. The best separation of procyanidins was achieved with a two-phase solvent system composed of butan-1-ol–(methyl *tert*-butyl ether)–acetonitrile–0.1 % TFA (2:4:3:8) using the lower phase as the mobile one. Successful CCC separations of catechins, glycosides of flavonoids, and procyanidins used in the analysis of food-related polyphenols are also reported [75].

A standard test mix consisting of 21 commercially available natural products of agricultural significance was employed to measure CCC performance characteristics of a solvent system family made up of hexane–ethyl acetate–methanol–water. An elution–extrusion CCC method and the systems chosen can be recommended for the analysis of various wines [76].

A special hydrodynamic CCC column with a 1-mm i.d. polytetrafluoroethylene (PTFE) tube was used for the analysis of ovalbumin obtained from various sources [77]. The CCC fractions of the ovalbumin from fresh egg white and from commercial products containing natural albumin and its denatured products were detected spectrophotometrically after the separation using biphasic aqueous systems containing PEO 1000 and K_2HPO_4 .

Environmental analysis

The technique can be useful in environmental analysis for preconcentration of trace organic substances from large volumes of water and other aqueous samples. For example, nonionic surfactants of the

alkylphenyl poly(oxyethylene) ethers (APEO) family, used in detergents, cleaners, and process aids, were successfully enriched from waste water on a Sanki CPC hydrostatic apparatus [78,79]. A concentration factor of 400 was achieved using ethyl acetate as stationary extracting phase.

The feasibility of using a hydrostatic CCC column to extract $\mu\text{g}/\text{kg}$ levels of phenols and organochlorine pesticides (OCPs) from aqueous samples has also been investigated [80]. The effects of extraction solvent (stationary phase) and its volume, sample loading flow rate, ionic strength, and presence of humic materials in the aqueous sample on the extraction of 13 phenols and 20 OCPs have been examined. The recovery data for these analytes extracted from spiked water and waste water samples are reported. Methylene chloride is more effective than hexane in extracting phenols but only slightly better than hexane in extracting OCPs. The target compounds are concentrated into a small volume of solvent (2 mL) from a relatively large volume of aqueous matrix (>100 mL).

Inorganic ions

Studies over the last 15 years have shown that the technique can be applied to analytical and radioanalytical separation and preconcentration of inorganic ions as well as to the purification of inorganic analytical reagents. CCC has potential in trace and ultratrace analysis for preconcentration of metals prior to instrumental multielement determination by atomic absorption spectrometry (AAS), inductively coupled plasma atomic emission (ICP/OES) and mass spectrometry (ICP/MS). In a CCC apparatus with plastic columns, inlet and outlet capillaries, the test solutions are only in contact with Teflon. This minimizes the risk of sample contamination. Besides, the solvents and reagents used can be purified before separation and preconcentration in the same column [81].

The use of only one column is also an advantage in the case of extracting analytes from solutions of very complex samples, e.g., geological materials, when two or more extraction systems are needed to recover target elements. It should be also mentioned that, as with organic or bioorganic separations, CCC allows one to work with crude samples containing colloid or solid particles. Because the CCC centrifuge is a closed system, it is convenient for working with radioactive fluids without the risk of exposing radionuclides. This is important for safe radiochemical studies. For the separation and preconcentration of inorganic substances by CCC, various two-phase liquid systems are used.

Due to the possibility of using a large range of liquid–liquid extraction (LLE) systems, CCC can be applied as a preconcentration and pre-separation technique for various elements before their instrumental determination [22,81–89].

Lanthanides and actinides

Triply charged cations of rare earth elements (REEs) are particularly difficult to separate due to their almost equal diameters and similar complexing abilities. Extraction and separation of REEs can help solve some analytical problems. Besides, separation of such elements may be a good test for estimating the separation efficiency of any technique.

1. Hydrostatic CPC centrifuges

The first work on the use of hydrostatic columns (CPC) for the separation of inorganic species was published in 1988 by Araki [90]. The separations were carried out with an extraction system based on bis(2-ethylhexyl) hydrogen phosphate (B2EHP) in toluene. Separations of La, Ce, Pr; La, Pr, Nd; Pr, Nd; Nd, Sm; and Sm, Eu using a variable HCl concentration (from 0.04 to 0.15 mol/L) were shown. The peak resolution can be improved by increasing the number of microcells (from 1200 to 2400) [91]. Later, Araki et al. [92] published their studies on the CPC behavior of the heavier REEs (Sm, Eu, Gd, Tb, Dy, Ho, Er, Tm, Yb, Lu) in the use of 0.01 mol/L B2EHP in chloroform at different HCl concentrations in the mobile phase and different temperatures. The separation time for the REEs was too long (2–4 h). A CPC separation of light lanthanides was successfully performed using a solution of B2EHP or tributyl phosphate (TBP) with unbranched alkane as a stationary phase and aqueous HNO_3 solutions

as a mobile phase [93–95]. Some other systems were used for the separation of Sc, Y, and triply charged REEs [96].

CPC was also used for analytical-scale separations of trivalent REEs by 0.1 mol/L Cyanex 272 [bis(2,4,4-trimethylpentyl) hydrogen phosphate] with heptane as stationary phase and water at the appropriate pH as mobile phase [33]. It was demonstrated for the first time that a mixture of REEs can be efficiently separated in a single run by CPC using gradient pH elution.

The separation of triply charged lanthanides with the extractants 1-phenyl-3-methyl-4-benzoyl-pyrazol-5-one (HPMBP) and 1-phenyl-3-methyl-4-capryloyl-pyrazol-5-one (HPMCP) in the toluene–water phase pair and the factors influencing the separation efficiencies have been investigated [97]. Significant differences were observed in the efficiencies of separations with HPMBP and HPMCP, which stem from differences in the interfacial dissociation rate constants of metal complexes and the interfacial areas generated, indicating that CPC separation of triply charged lanthanide ions with acylpyrazolones in the toluene–water phase pair is driven mainly by interfacial processes.

The separation of Nd^{III}, U^{IV}, and U^{VI} was successfully performed in about 1 h by selecting 30 % solution of TBP in *n*-dodecane as the stationary phase and 0.3 mol/L HNO₃–0.05 mol/L hydrazine as the mobile phase [23]. Americium was separated from lighter lanthanides using a solution of 5,8-diethyl-7-hydroxydodecan-6-one oxime (LIX 63) in kerosene as a stationary phase [98].

2. High-speed hydrodynamic centrifuges (HSCCC)

Ito [99] separated REEs using a B2EHP-based two-phase system. The peak resolution between La and Pr was 6.95, and that between Pr and Nd was 1.74. To further demonstrate the capabilities of the method, a one-step separation of all 14 REEs was performed using an exponential gradient of HCl concentration in the mobile phase [100]. The whole group of REEs was also separated in a system of dihexyl-*N,N*-diethylcarbamoyl methylenephosphonate (DHDECMP) in cyclohexane–HNO₃ [101]. Unfortunately, the separation time was as long as 2 h.

REEs were enriched into the stationary phase comprised of bis(2-ethylhexyl) hydrogen phosphate solution in toluene from a large volume of aqueous solution, and then chromatographically eluted by the mobile phase with stepwise pH gradient [102–106]. The separation parameters (N and R_S) were found to be practically independent of the revolution speed and flow rate provided the retention ratio (S_F) of the stationary phase remained constant [102]. The separation of REE with separation factor (α) as low as 1.86 (Y/Ho) and 1.51 (Er/Y) was almost completely achieved in a single CCC step with a good peak resolution ($R_S = 1.55$ for Y/Ho and 1.05 for Er/Y [102]).

A CCC technique was utilized practically for the preconcentration and separation of trace REEs from major constituents of various geological samples after their decomposition, for subsequent determination by ICP/OES and MS [88,90]. Three extraction systems on the basis of B2EHP, trioctylphosphine oxide (TOPO) and diphenyl(dibutylcarbamoylmethyl)phosphine (Ph₂Bu₂) were shown to be applicable to the group separation of REEs from dissolved samples of rocks, ores, and minerals (basalts, granites, dolomite, fluorite-barite-hydroapatite ore, syenite, etc.). A one-stage separation of REEs from most of the matrix components was achieved (Fig. 6). The proposed methods of group separation of REEs by CCC due to their simplicity, versatility, and relatively short separation times, can easily compete with other methods [107,110].

The determination of Nd and Sm isotope concentrations in rock samples is another analytical problem which can be solved using CCC [88]. The ratio of these isotopes allows one to judge the age of rocks. The quality of MS analysis depends on the purity of element fractions to be analyzed. As Nd and Sm have isotopes of equal mass, Nd must be completely separated from Sm. Besides, the isolated Nd and Sm fractions should be free from some contaminant elements (Ba, Ca, Fe, and others) which may interfere with ionization in MS. The 1.0 mol/L B2EHP in decane–HCl system was used for the separation of Nd and Sm as well as for the isolation of both elements from the majority of main constituents of geological materials [22] (Fig. 7).

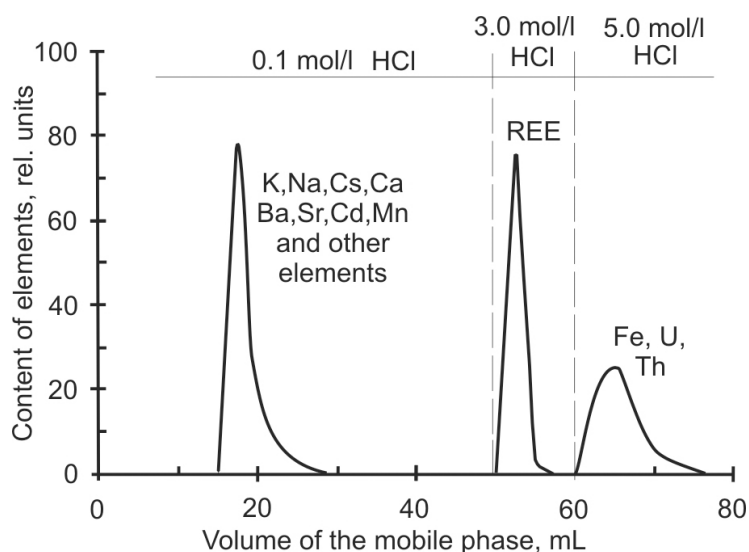

Fig. 6 CCC separation of REEs from some macrocomponents present in geological samples using step pH gradient, mobile phase: HCl solution with increasing concentration; stationary phase: 0.5 mol/L B2EHP in decane. Hydrodynamic CCC column, 16 mL, $S_F = 0.5$, $F = 1.2$ mL/min. Adapted from [22].

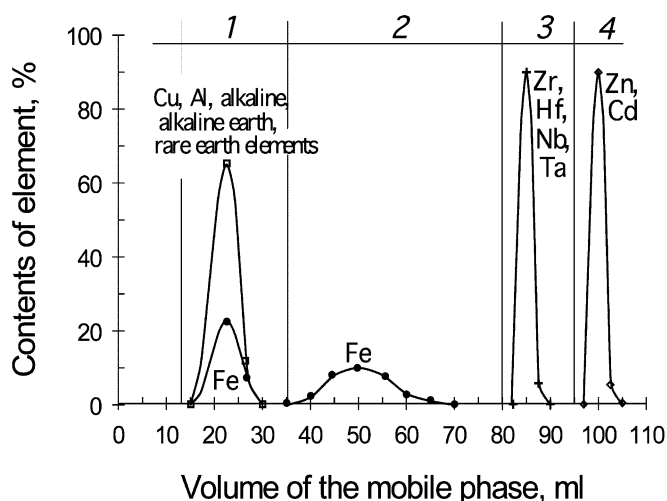

Fig. 7 Preconcentration and separation of Zr, Hf, Nb, Ta from matrix components. Hydrodynamic CCC column ($V_C = 24$ mL). Stationary phase: chloroform solution of TOEDA (0.1 mol/L). Mobile phases: 1-aqueous solution of HCl 0.1 mol/L + oxalic acid 0.1 mol/L; 2-HCl 0.1 mol/L + oxalic acid 0.5 mol/L; 3-HCl 2 mol/L; 4-nitric acid 2 mol/L. $S_F = 0.5$ ($V_S = 12$ mL); $F = 1$ mL/min. Adapted from [22].

A procedure for the entire REE group pre-concentration from high-purity calcium chloride and subsequent determination of the ultratrace elements by ICP/MS has been developed [111]. A solution of diphenyl(dibutylcarbamoylmethyl)phosphine oxide in chloroform (0.5 mol/L) was chosen as reagent for the extraction and pre-concentration of REEs from an aqueous 5% CaCl_2 solution. The concentrate of REEs was eluted into a small volume of water, and the aqueous eluate was subjected to ICP/MS measurements. The performance characteristics of the procedure have been checked by analyzing a real

CaCl₂ sample (Merck product). The results obtained demonstrate the applicability of CCC to ultratrace analysis.

Extraction systems based on bidentate neutral organophosphorus reagents were suggested to be applicable to the group separation of trivalent transplutonium elements (TPEs) from trace and macroamounts of REEs [112–114]. Higher partition constants for all TPEs than for all REEs is the main advantage of these systems. The separation takes only 17–20 min in a 20-mL column rotated at 500 rpm. Isocratic separation of the elements is possible, but the separation by step elution is more convenient as this way results in smaller eluent volumes.

The effects of concentration of extractant, pH and the flow rate of mobile phase on the separation efficiency of Am and Eu by CCC were investigated using dichloro phenyldithiophosphinic acid in xylene as the stationary phase and 0.1 mol/L NaClO₄ as mobile phase [115]. The results show that the separation factor grows with increasing the concentration of extractant and the pH value of the mobile phase. Mutual separation between Am^{III} and Eu^{III} can be accomplished by optimizing the separation condition, the separation factor, and separation efficiency between Am^{III} and Eu^{III} + can reach 2.87 and 0.74, respectively.

The separation of Am from lighter lanthanides has been performed on a small coiled column (10 mL) [116]. An extractant having a high affinity for Am, LIX 63 was employed as a stationary phase. The peaks of ²⁴¹Am and ¹⁵²Eu were clearly separated from each other.

The quantities and the isotopic compositions of plutonium released into the environment are a concern for environmental and radiochemistry. The results of the analysis of ultratrace plutonium in soil by use of CCC separation followed by ICP/MS determination have been published [117]. The matrix effect (polyatomic interferences) was minimized by using a CCC pre-separation step with a 20 % trioctylamine solution in toluene as a stationary phase. The interfering matrix elements, thorium and uranium, were eluted by using 7.5 mol/L HNO₃, 10 mol/L HCl, and 3 mol/L HNO₃, respectively. The separation factor was 105 for thorium and 104 for uranium. Plutonium was almost completely recovered using 5 mL 0.025 mol/L oxalic acid–0.15 mol/L HNO₃ [118].

The separation capability of hydrodynamic CCC columns with respect to actinides was usually found to be superior to that of hydrostatic columns (CPC) [119].

Zr^{IV}, Hf^{IV}, Ta^V, and Nb^V

Group pre-separation of Zr^{IV}, Hf^{IV}, Ta^V, and Nb^V is desirable in the analysis of geological samples of different composition containing trace amounts of these elements.

Preconcentration of Zr and Hf and their separation from Fe (macro component which is most often a source of spectral interferences) makes it possible to decrease the inter-element influence and to improve the sensitivity of their determination by ICP/OES. Preconcentration and separation of Zr and Hf on a hydrodynamic CCC column with a one-layer coil (volume 17 mL, rotation speed 450 rpm) in a system on the basis of a mixture of two extracting reagents, B2EHP and *N*-benzoyl-*N*-phenylhydroxylamine (BPHA), was achieved [88]. The separation was performed by step elution. In the first stages, Zr and Hf were concentrated in the stationary phase, while Fe and other elements were eluted. Then Zr and Hf were eluted using an oxalic acid solution as the mobile phase.

A system with tetraoctyl “ethane-1,2-diamine” in chloroform can be applied to preconcentration of Zr, Hf, Nb, Ta for their determination in geological samples [90]. At the concentration stages, alkali, alkaline-earth, and rare earth elements, Fe, Al, Cu, were removed from the column. Then Zr, Hf, Nb, and Ta were separated into 10 mL of 2 mol/L HCl. Zn and Cd were eluted with 1 mol/L HNO₃ at the stationary-phase regeneration stage.

Using 0.001 mol/L 1-phenyl-3-methyl-4-benzoyl-5-pyrazolone in “isobutyl methyl ketone” as stationary phase, separation of Zr and Hf can be achieved [90,120]. The separation was performed by step elution.

Alkali and alkaline-earth elements

Systems of 0.01 mol/L cobalt dicarbollide (CD)–nitrobenzene–HNO₃ solution and 0.05 mol/L dicyclohexano-18-crown-6 (DCH18C6)–3 % B2EHP–chloroform–HNO₃ solution were used for the separation of radionuclides of Cs and Sr [87,121]. The application of the stationary phase on the basis of CD enables the concentration of Cs and Sr to be achieved. Elution of Cs and Sr from the stationary phase on the basis of DCH18C6 and B2EHP into a mobile phase, containing barium nitrate, PEO, and nitric acid, was studied. Different variants of Cs and Sr separation by changing the composition of the mobile phase can be obtained. The quantitative elution and complete separation of Cs and Sr by means of one eluent or by step elution is possible. The latter procedure is quicker and enables stripping of the elements using less mobile phase. The value of theoretical plate number (*N*) varies from 77 to 836, which is adequate for the separations described.

Extraction systems based on crown ethers are known to be suitable for the separation of Rb, Ca, Sr, and Ba [122]. An example of the separation of Sr from the other elements on a hydrodynamic column with a one-layer coil in the 0.1 mol/L DCH18C6–chloroform–5.0 mol/L HNO₃ phase system was reported. Selective separation of Rb can also be achieved in a DCH18C6-based system but with the use of picrate (Pi⁻) instead of nitrate as Pi⁻ is the better counter-ion for metal–crown ether cationic complexes.

Platinum group metals

The separation of Pd^{II} from Pt^{III}, Ir^{III}, and Rh^{III} with TOPO in heptane using a CPC centrifuge was investigated [123]. The separation of Pd from Pt is achieved in the 0.5 mol/L TOPO in heptane–0.1 mol/L HCl system with a peak resolution of 1.54 and <0.3 % peak overlap. The same system was used for the separation of Pd from the other Pt group metals.

The CPC separation efficiencies for distributing species, a Pt ion complex, and an organic solute (3-picoline) for the heptane–water pair have been compared [124]. The analysis of chromatographic efficiency in separations involving the partition of metal complexes clearly reveals the influence of the kinetics of complex formation and dissociation on the chromatographic efficiencies and affords a semi-quantitative description of the relevant kinetic parameters.

Various elements

1. Hydrostatic CPC centrifuges

A method has been developed for the mutual separation of such metal ions as Cu^{II}, Mn^{II}, Co^{II}, and Ni^{II} with di-2-methylnonylphosphoric acid in heptane as a stationary phase [125]. The CPC system was operated with 2136 partition channels, at a rotational speed of 800 rpm. The four metal ions can be eluted separately by changing the pH of a chloroacetic acid solution as a mobile phase in two steps. The elution curves were obtained by monitoring the absorbance of each metal complex post-labeled with 4-(2-pyridylazo)resorcinol.

The separation of Fe^{III}, Zn^{II}, Cu^{II}, Co^{II}, and Ni^{II} has been investigated by using 0.16 mol/L bis(2-ethylhexyl)phosphoric acid in heptane as a stationary phase [126]. Acetate, chloroacetate, and tartrate buffers were used as mobile phases. The Co^{II} cations present in unrefined Ni^{II} sulfate solution could also be separated by this method. The sample solution was continuously delivered into the stationary phase, and the Co^{II} cations were found to be retained in the stationary phase. The CPC system was operated with 2136 partition channels at a rotation speed of 800 rpm.

2. Hydrodynamic centrifuges (HSCCC)

The separation of Co^{II}, Cu^{II}, Fe^{II}, Fe^{III}, Ni^{III}, and Mg was performed with a hydrodynamic CCC column [127]. The separation, using B2EHP in heptane (stationary phase) and diluted citric acid (mobile phase), can be optimized by selecting a proper acid concentration. Continuous detection of the elements was performed by direct current plasma atomic emission spectrometry. Each element peak was well resolved, *N* ranging from 200 to 3600. The mg/kg levels of metal ions in 500 mL of the mobile phase were continuously concentrated into small volumes of the stationary phase (B2EHP in heptane) retained

in the column [128]. Concentrated metal ions were eluted with nitric acid and then determined. The versatility of the present method was further demonstrated in the determination of trace metals in different waters.

Metal ions were efficiently enriched by pH peak focusing HSCCC [129]. The peak intensity for a 10-mL standard sample in the effluent stream was increased over 100-fold (detection by ICP/OES). Ca, Cd, Cu, Mg, Mn, Ni, and Zn are chromatographically extracted into an organic stationary phase containing B2EHP. After the sample solution was introduced into the column, metal ions remain around the sharp pH border formed between acidic and basic zones, moving toward the column outlet. Enriched metal ions are finally eluted with the sharp pH border as a highly concentrated peak into a volume of less than 100 mL. The present method was evaluated in terms of concentration efficiency and peak resolution of a target element from matrices in trace analysis of environmental samples under different conditions [130].

Fe^{II} and Fe^{III} were separated using a step elution of decreasing pH with a stationary phase containing 5 mmol/L TPMPDP in *n*-decane and a hydrodynamic CCC column with a small single coil of 16 mL [131].

Displacement chromatography is a way of using the chromatographic technique in which the solutes are separated in bands in the stationary phase. Because the stationary phase is a liquid in CCC, it is possible to stop the displacement process when the separated bands are still in the stationary phase. The collection of the stationary-phase bands is possible. This way of using a CCC instrument was described for the separation of transition-metal ions. Co^{II}, Ni^{II}, Cu^{II}, and Zn^{II} were separated using B2EHP in heptane as the stationary phase through a reversed micelle extraction process [132]. The displacement process and collection of the stationary heptane phase allowed the recovery of ion bands with purity higher than 95 %. The papers [103,104,106] are interesting theoretically as they show the possibility of using pH peak focusing and displacement chromatography for CCC separations of metal ions. However, the procedures described can be doubtfully recommended for practical applications because there are a number of excellent separation and preconcentration methods for the elements studied, particularly in water analysis.

Purification of salt solutions by CCC

The applicability of CCC has been investigated to the purification of salt solutions (to gain high-purity reagents, which, after evaporation, can be used for fusion decomposition purposes in trace analysis of high-tech ceramics and other materials) [133].

There is a difference in the aims of analytical preconcentration and purification procedures: in the case of purification, the purified constituent of an aqueous solution is the target component, while the trace elements (TEs) are considered as impurities to be separated and discarded. In this case, the maximum possible number of TEs should be separated in one chromatographic run. Other requirements to be met in the use of any purification method are connected with the purity of all the chemicals applied and with the necessary minimum decontamination of the solutions involved, which may be due to their contact with the device materials. As was mentioned before, when using a hydrodynamic CCC column, the solutions are only in contact with Teflon, which is one of the most known inert materials.

The possibility of the purification of aqueous solutions of inorganic salts, such as (NH₄)₂SO₄, NH₄F, and NH₄Cl, from a number of the most common metal impurities was shown by using azepan-1-ylthioformic acid, diethylammonium diethylthiocarbamate, 8-hydroxyquinoline, dibenzo-18-crown-6 (DB18C6), and DCH18C6 as extracting reagents. The solution obtained is free from Fe, Cu, Zn, Co, Cd, Ni, Mn; this testifies the complete purification of the salt solution from the elements listed. It should be noted that the contamination of the solutions by the column material, reagents, and organic solvents was controlled. Contents of elements in water and 2 mol/L HCl passing through the column were less than the detection limits for electrothermal atomic absorption spectrometry (ET/AAS).

A mixture of HMDTCA, DCH18C6, and DB18C6 in chloroform makes possible the purification of 1 % $(\text{NH}_4)_2\text{SO}_4$ solution from K, Fe, Cu, Zn, Co, Cd, Ni, Al, Mn; their concentrations in the purified solution were below the detection limits for ET/AAS.

Therefore, varying the organic phase composition can provide the “complete” purification of the salt solution from contaminant TEs.

OTHER APPLICATIONS OF HYDRODYNAMIC CCC COLUMNS

So far, the separation of solutes in liquid–liquid phase systems has been described. But it is also possible to use liquid–solid–liquid and liquid–solid systems as well. The use of suspended particulate matter as the stationary phase has offered the challenge for a series of promising unconventional applications of planetary centrifuges in the analysis of environmental solid samples. A new effective method for the direct recovery of toxic organic substances (polycyclic aromatic hydrocarbons, PAHs) from liquid sewage sludge [134] and soil [135] has been proposed. A new continuous-flow method has been also developed that enables not only the fast and efficient fractionation of TE species in soils and sediments to be achieved but allows time-resolved (kinetic) studies on the mobilization of trace and major elements in different forms to be made [136–138]. The method is time-saving and requires only 4–5 h instead of the several days needed for routine sequential extraction (traditionally used for the fractionation of TEs to assess their mobility and potential bioavailability). On-line coupling of leaching by hydrodynamic CCC columns and ICP/OES measurements has been proposed [139]. This enables real-time data on the leaching process to be obtained. It has been also demonstrated that hydrodynamic columns can be successfully used in this new field of application: for the fractionation of microparticles [140,141]. There is no conventional stationary phase in this case. The centrifugal forces acting on hydrodynamic CCC columns provide different migration speeds of the suspended sample components in one carrier fluid.

Recovery of PAHs from liquid sewage sludge and soil

Organic contaminants, e.g., PAHs, are widespread in the environment as a result of human activities. The fast and correct determination of these pollutants in soils, sediments, and sewage sludge is a vital necessity for environmental management. The extraction of analytes from solid samples remains the critical step in the analysis of contaminants.

A series of extraction methods have been proposed for the recovery of PAHs. In most cases, more or less laborious clean-up procedures are required before the instrumental determinations of PAHs in extracts.

Hydrodynamic centrifuges can be used for the direct extraction and separation of some organic substances (e.g., xenobiotics) from a sewage sludge medium [135]. It has been shown that heterogeneous samples can be retained in the rotating column. The sewage sludge (being in fact a concentrated suspension) was the stationary phase in the column, whereas organic solvents (heptane, dichloromethane) or their mixtures were used as mobile phase. The volume of suspension retained in the column is dependent on the difference in densities between stationary and mobile phases, and operational parameters of the centrifuge. Although the subsequent separation of PAHs from the sewage sludge medium has been performed, a group separation of PAHs followed by their quantitative determination by HPLC with a fluorescence detector can be more useful. The procedures developed look promising and can be recommended to analyze crude samples (such as sewage sludge) without any sample pretreatment.

In addition, the use of appropriate “mild” solvents for dynamic extraction using these centrifuges may be very perspective for the simulation of naturally occurring processes and determination of environmentally relevant forms of PAHs and other pollutants in environmental solids.

Continuous-flow fractionation of TEs in environmental solids

Mobility and bioavailability of TEs in soils, sediments, and sludge depend strongly on their chemical forms and type of binding, i.e., sorption/desorption processes may significantly affect the toxicity of metals in the natural environment [142]. Consequently, the data on total contents of elements are quite insufficient to estimate the possible risk of mobilization of TEs and potential uptake of liberated elements by biota. Thus, analytical techniques and procedures for distinguishing different forms (species) of TEs are required. An approach that has been found to be preferable is the fractionation of TEs into *operationally defined* forms under the sequential action of different extractants. Selective extractants, used in the sequential extraction procedures, are aimed at the simulation of natural conditions whereby TEs associated with certain soil (sediment) components can be released. For example, changes in the ionic composition affecting adsorption/desorption reactions may lead to the release of elements, retained on a matrix by weak electrostatic interactions. Decreasing the redox potential can result in dissolution of oxides, unstable under reducing conditions. The sequential extraction should be recommended to obtain more or less detailed information on the origin, biological and physicochemical bioavailability, mobilization, and transport of TEs.

A new continuous-flow technique has been proposed that enables not only the fast and efficient fractionation of TE species in soils and sediments to be achieved but also allows time-resolved (kinetic) studies on the mobilization of TEs in different forms to be made [137–140]. A particulate sample was retained in the rotating column as the stationary phase under the action of centrifugal forces while aqueous solutions of complexing reagents, mineral acids, and salts were continuously pumped through. The procedure developed is time-saving and requires only 4–5 h instead of several days needed for traditional sequential extraction, complete automation being possible.

COMPARISON WITH OTHER ANALYTICAL TECHNIQUES, USAGE RECOMMENDATIONS, AND CONCLUSIONS

Although CCC is an efficient separation technique, generally insufficient attention has been given to analytical CCC, whereas numerous excellent applications of preparative CCC have been reported over the past decades. One of the main purposes of this paper is to draw a wider attention of the analytical community to this interesting method. Because analytical chemists have a good choice of separation and preconcentration techniques for various substances in solutions and because CCC, as any other method, has its own advantages and disadvantages, it is necessary to compare CCC with other methods for separation and enrichment of similar analytes in order to outline the niche of CCC in analytical chemistry. Some comparisons were made above when describing the principles of CCC and its analytical applications.

CCC is most often compared with one-stage LLE. The comparison with LLE is useful for several reasons. From the physicochemical point of view, LLE and CCC are both based on the partition of substances between two support-free liquid phases. The difference is that LLE just makes a single exchange (one plate) when CCC, with its moving mobile phase and stationary phase, automatically performs a great number of exchanges (several theoretical plates). A similar comparison can be made between the single exchange obtained with solid-phase extraction (SPE) and the multiple exchanges observed with HPLC. One of the big advantages of the LLE methods consists in the possibility of the extraction of very large amounts of substances since they can access the volume of the two phases and not only the surface of a solid phase as in SPE. This is why LLE is widely used as a purification tool, but not only on a laboratory scale, and a huge amount of information on the chemistry and hydrodynamics of LLE of various compounds has been accumulated by chemists and chemical engineers. The wealth of this information can be applied to the prediction of the behavior of substances in CCC, of course, taking into account the specific features of CCC. Another advantage of both LLE and CCC over other LC techniques, capillary electrophoresis (CE) and related methods is the possibility to work with strongly

acidic and alkaline solutions that may be important, particularly in inorganic and radiochemical analysis where such solutions are often used.

CCC is a multistage technique that enables incomparably better separations than conventional multiple extractions in separatory funnels. In LLE technologies, multistage processes are applied by use of extraction cascades consisting of one- or few-stage apparatus like mixer-settlers, different columns, or centrifugal contactors. Such equipment is not practical for analytical laboratories because of its cost, large minimum volumes, and the smaller number of plates which can be realized on a reasonably small apparatus. CCC centrifuges are much more convenient for laboratory use.

CCC will never substitute for such an excellent technique as HPLC but can supplement it in solving certain analytical problems. Although CCC shows a lower efficiency and requires a longer separation time compared to methods such as HPLC and CE, it has several merits. Since the CCC column requires no solid support, CCC is free from adsorption of solutes to the column, and the recovery of samples and reagents without contamination or decomposition is possible. An additional benefit is that it should be possible to use the same column repeatedly for separations with different stationary phases.

As has been shown above, CCC can be used for the enrichment of different analytes before their detection. Sorption methods are currently the leader among the analytical techniques for the preconcentration of various substances by use of different adsorbents. Although numerous effective adsorption materials are known, it is possible to compare CCC with SPE on alkyl silicas. Alkyl-bonded silica gels are a unique class of adsorbents that can be applied to the enrichment of a great number of substances, ranging from biomolecules and organic compounds [143] to inorganic ions [144]. SPE on alkyl-bonded silica gels should be considered as an adsorption technique, but the method has also much in common with LLE because the alkyl layer on the silica surface behaves like an organic solvent in LLE or CCC.

The range of substances which can be extracted and preconcentrated by CCC from aqueous sample solutions is almost as wide as in SPE. CCC can be used for the recovery of analytes from organic media that is hardly possible with alkyl-bonded phases: organic solvents are utilized for the elution of preconcentrated substances from such phases. Particulate matter, soluble polymers (e.g., humic substances), and other components of "crude" samples may clog the SPE cartridges as well as HPLC columns and cause difficulties in CE studies. The examples of CCC application given above show that CCC is much less sensitive to the composition of crude samples. The advantage of SPE over CCC is the ease of use, the lower cost of the devices, and the possibility to obtain smaller-volume eluates (concentrates). The adsorption methods enable rapid isolation of the analytes of interest with a preconcentration factor of several orders of magnitude achieved in minutes. This is practically impossible with CCC. These and other disadvantages and advantages of different separation methods compared with CCC are summarized in Table 3.

Table 3 Advantages and disadvantages of other analytical techniques compared to CCC.

Technique	Advantage	Disadvantage
LLE	Low cost of single-stage extraction (SSE)	Low peak resolution of SSE. High cost and large minimum volumes of conventional extraction cascades
SPE and related enrichment techniques	Low cost. Higher flow rates for small-volume cartridges (membranes)	Low peak resolution
HPLC	Availability of various commercial detectors and interfaces, fully automatized	Much more narrow acidity range of solutions, easy column overload, loss of sample by irreversible adsorption, high cost of columns
CE	Small sample volume Short separation time	Low relative sensitivity and reproducibility
HPLC, CE	High separation efficiency	Sensitivity to solution composition
HPLC, SPE	Short separation time	Contamination or deactivation due to solid supports. Clogging of columns (cartridges)

In conclusion, we can formulate some recommendations on the use of CCC in the following fields of analytical chemistry (mostly as a pretreatment technique):

- Analysis of samples containing solid or colloid particles, high-molecular, and other constituents which may plug LC columns, adsorption enrichment cartridges, and filters, and interfere with CE and other separations.
- Isolation and separation of biological materials which may be denatured and lost due to strong or irreversible interactions with a solid support. Works with any substances irreversibly adsorbed onto the LC column packing materials.
- Analysis of solutions containing high concentrations of acids, bases, salts, and other soluble sample components which may interfere with the pre-separation by other techniques and subsequent determination of analytes.
- Radioanalytical studies to reduce the risk of exposing radionuclides by use of a closed CCC system.
- Ultratrace inorganic analysis. The use of a CCC column where the sample is in contact with only Teflon minimizes the risk of sample contamination.
- Purification of analytical reagents.
- Preparation of standard reference materials.

ABBREVIATIONS AND ACRONYMS

ATPS	aqueous two-phase system
APEO	alkylphenol ethoxylate
AAS	atomic absorption spectrometry
CCC	countercurrent chromatography
CE	capillary electrophoresis

CPC	centrifugal partition chromatograph
B2EHP	bis(2-ethylhexyl) hydrogen phosphate
F	volume flow rate (mL min^{-1})
GA	gibberellin
GC	gas chromatography
HSCCC	high-speed countercurrent chromatography
ICP/OES	inductively coupled plasma/optical emission spectroscopy
ICP/MS	inductively coupled plasma/mass spectrometry
k	retention factor
K_D	partition ratio
LLE	liquid–liquid extraction
LC	liquid chromatography
N	theoretical plate number
OCP	organochlorine pesticide
PEO	poly(ethylene oxide)
REE	rare earth element
R_S	peak resolution factor
S_F	stationary-phase volume retention ratio
SPE	solid-phase extraction
TBP	tributyl phosphate
TOEDA	tetraoctylethylenediamine
TOPO	trioctylphosphine oxide
TPE	trivalent transplutonium element
V_C	column volume
V_M	mobile-phase volume
V_R	peak retention volume
V_S	stationary-phase volume
α	separation factor
w_b	average peak width

REFERENCES

1. L. S. Ettre. *Pure Appl. Chem.* **65**, 819 (1993).
2. A. Berthod (Ed.). *Comprehensive Analytical Chemistry: The Support-Free Liquid Stationary Phase*, Comprehensive Analytical Chemistry, Vol. 38, Elsevier, Amsterdam (2002).
3. Y. Ito. In *Countercurrent Chromatography: The Support-Free Liquid Stationary Phase*, A. Berthod (Ed.), Comprehensive Analytical Chemistry, Vol. 38, pp. xix–xx, Elsevier, Amsterdam (2002).
4. Y. Ito, W. D. Conway (Eds.). *Chemical Analysis*, Vol. 132, John Wiley, New York (1996).
5. W. D. Conway. *Countercurrent Chromatography, Apparatus, Theory and Applications*, VCH, Weinheim (1990).
6. N. B. Mandava, Y. Ito (Eds.). *Countercurrent Chromatography*, Chromatographic Science Series, Vol. 44, Marcel Dekker, New York (1988).
7. A. P. Foucault (Ed.). *Centrifugal Partition Chromatography*, Chromatographic Science Series, Vol. 68, Marcel Dekker, New York (1995).
8. J. M. Menet, D. Thiebault (Eds.). *Countercurrent Chromatography*, Chromatographic Science Series, Vol. 82, Marcel Dekker, New York (1999).
9. W. D. Conway, R. J. Petroski. *Modern Countercurrent Chromatography*, ACS Symposium Series No. 593, American Chemical Society, Washington, DC (1995).
10. A. García Domínguez, J. C. Díez Masa. *Pure Appl. Chem.* **73**, 969 (2001).

11. A. Berthod, B. Billardello. *Advances in Chromatography*, Vol. 40, P. Brown, E. Grushka (Eds.), p. 8, Marcel Dekker, New York (2000).
12. A. Berthod. In *Centrifugal Partition Chromatography*, A. P. Foucault (Ed.), Chromatographic Science Series, Vol. 68, p. 167, Marcel Dekker, New York (1995).
13. I. A. Sutherland, J. de Folter, P. L. Wood. *J. Liq. Chromatogr. Rel. Technol.* **26**, 1449 (2003).
14. P. L. Wood, D. Hawes, L. Janaway, I. A. Sutherland. *J. Liq. Chromatogr. Rel. Technol.* **26**, 1373 (2003).
15. A. Marston, K. Hostettmann. *J. Chromatogr., A* **658**, 315 (1994).
16. Y. Ito. *J. Chromatogr., A* **1065**, 145 (2005).
17. T. A. Maryutina, B. Ya. Spivakov. In *Encyclopedia of Chromatography*, J. Cazes (Ed.), p. 137, Marcel Dekker, New York (2001).
18. Yu. A. Zolotov, B. Ya. Spivakov, T. A. Maryutina, V. L. Bashlov, I. V. Pavlenko. *Fresenius' J. Anal. Chem.* **335**, 938 (1989).
19. S. Muralidharan, H. Freiser. In *Metal-Ion Separation and Preconcentration. Progress and Opportunities*, A. H. Bond, M. L. Dietz, R. D. Rogers (Eds.), ACS Symposium Series No. 716, chap. 21, p. 347, American Chemical Society, Washington, DC (1999).
20. H. Abe, S. Usuda, H. Takeishi, S. Tachimori. *J. Liq. Chromatogr., A* **16**, 2661 (1993).
21. E. Kitazume, M. Bhatnagar, Y. Ito. *J. Chromatogr., A* **538**, 133 (1991).
22. T. A. Maryutina, P. S. Fedotov, B. Ya. Spivakov. In *Countercurrent Chromatography*, J. M. Menet, D. Thiebaut (Eds.), Chromatographic Science Series, Vol. 82, chap. 6, p. 171, Marcel Dekker, New York (1999).
23. W. D. Conway. *J. Liq. Chromatogr.* **13**, 2409 (1990).
24. A. Berthod. *Analysis* **18**, 352 (1990).
25. A. Berthod, M. J. Ruiz-Angel, S. Carda-Broch. *Anal. Chem.* **75**, 5886 (2003).
26. J. B. Freisen, G. F. Pauli. *J. Liq. Chromatogr. Rel. Technol.* **28**, 2777 (2005).
27. I. J. Garrard, L. Janaway, D. Fisher. *J. Liq. Chromatogr. Rel. Technol.* **30**, 151 (2007).
28. A. Berthod, M. Hassoun, M. J. Ruiz-Angel. *Anal. Bioanal. Chem.* **383**, 327 (2005).
29. P. S. Fedotov, T. A. Maryutina, V. M. Pukhovskaya, B. Ya. Spivakov. *J. Liq. Chromatogr.* **17**, 3491 (1994).
30. D. E. Schaufelberger. In *High-Speed Countercurrent Chromatography*, Y. Ito, W. D. Conway (Eds.), p. 45, John Wiley, Chichester (1996).
31. N. B. Manadava, Y. Ito. *J. Chromatogr.* **247**, 315 (1982).
32. D. E. Schaufelberger. *J. Chromatogr.* **538**, 45 (1991).
33. B. Billardello, A. Berthod. In *Countercurrent Chromatography—the Support-free Liquid Stationary Phase*, A. Berthod (Ed.), p. 177, Elsevier, Amsterdam (2002).
34. N. B. Mandava, Y. Ito. *J. Liq. Chromatogr., A* **7**, 303 (1990).
35. L. Qi, Y. Ma, Y. Ito, H. M. Fales. *J. Liq. Chromatogr. Rel. Technol.* **21**, 83 (1998).
36. C. S. Yeh, T. Yu, A. Berthod. *J. Liq. Chromatogr. Rel. Technol.* **22**, 345 (1999).
37. A. Marston, K. Hostettmann. *J. Chromatogr., A* **1112**, 181 (2006).
38. B. Gosse, A. A. Amissa, F. A. Adje, F. B. Niamke. *J. Liq. Chromatogr. Rel. Technol.* **28**, 2225 (2005).
39. A. Marston, I. Slacanin, K. Hostettmann. *Phytochem. Anal.* **1**, 3 (1990).
40. T. Y. Zhang. In *High-Speed Countercurrent Chromatography*, Y. Ito, W. D. Conway (Eds.), p. 225, John Wiley, Chichester (1996).
41. T. Y. Zhang, L. K. Pannell, Q. L. Pu, D. G. Cai, Y. Ito. *J. Chromatogr.* **442**, 455 (1988).
42. F. Yang, T. Zhang, R. Zhang, Y. Ito. *J. Chromatogr.* **829**, 137 (1998).
43. H. Oka, F. Oka, Y. Ito. *J. Chromatogr.* **479**, 53 (1989).
44. D. E. Schaufelberger. *Planta Med.* **6**, 84 (1989).
45. D. E. Schaufelberger. *J. Chromatogr.* **538**, 45 (1991).
46. L. J. Chen, D. E. Games, J. Jones. *J. Chromatogr., A* **988**, 95 (2003).

47. L. J. Chen, D. E. Games, J. Jones, H. Kidwell. *J. Liq. Chromatogr. Rel. Technol.* **26**, 1623 (2003).
48. L. J. Chen, H. Song, X. Q. Lan, D. E. Games, L. A. Sutherland. *J. Chromatogr., A* **1063**, 241 (2005).
49. G. Tian, T. Zhang, Y. Zhang, Y. Ito. *J. Chromatogr., A* **945**, 281 (2002).
50. F. Yang, T. Zhang, G. Xu, E. E. Chou, Y. Ito. *J. Liq. Chromatogr. Rel. Technol.* (Special Issue) **24**, 1617 (2001).
51. F. Yang, T. Zhang, G. Tian, H. Cao, Q. Liu, Y. Ito. *J. Chromatogr., A* **858**, 103 (1999).
52. H. Oka, Y. Ikai, N. Kawamura, M. Yamada, J. Hayakawa, K. I. Harada, K. Nagase, H. Murata, M. Suzuki, Y. Ito. *J. High Resolut. Chromatogr.* **306** (1991).
53. Y. W. Lee, Y. Ito, Q. C. Fang, C. E. Cook. *J. Liq. Chromatogr.* **11**, 75 (1988).
54. N. B. Mandava, Y. Ito, J. M. Ruth. *J. Liq. Chromatogr.* **8**, 2221 (1985).
55. Y. W. Lee, C. E. Cook, Q. C. Fang, Y. Ito. *J. Chromatogr.* **477**, 434 (1989).
56. H. Oka, Y. Ikai, N. Kawamura, M. Yamada, K. I. Harada, M. Suzuki, F. E. Chou, Y. Lee, Y. Ito. *J. Liq. Chromatogr.* **13**, 2309 (1990).
57. Y. Ito, Y. W. Lee. *J. Chromatogr.* **391**, 290 (1987).
58. T. Okuda, T. Yoshida, T. Hatano. *J. Liq. Chromatogr.* **12**, 2447 (1988).
59. P. Winterhalter. *Abstracts of Papers of the American Chemical Society* **214**, 1 (1997).
60. P. Winterhalter, H. Knapp, M. Straubinger, S. Fornari, N. Watanabe. *Challenges in Isolation and Characterization of Flavor Compounds*, C. J. Mussinan, M. J. Morello (Eds.), p. 181, American Chemical Society, Washington, DC (1998).
61. H. Oka, Y. Ikai, N. Kawamura, J. Hayakawa, K. Harada, H. Murata, M. Suzuki, Y. Ito. *Anal. Chem.* **63**, 2861 (1991).
62. H. Oka. In *High-Speed Countercurrent Chromatography*, Y. Ito, W. D. Conway (Eds.), p. 73, John Wiley, Chichester (1996).
63. H. Oka, Y. Ito. In *Encyclopedia of Chromatography*, J. Cazes (Ed.), p. 208, Marcel Dekker, New York (2001).
64. H. Oka, Y. Ito. *Abstracts of Papers of the 4th International Conference on Countercurrent Chromatography* 41 (2006).
65. Y. W. Lee, R. D. Voyksner, T. W. Pack, C. E. Cook. *Anal. Chem.* **62**, 244 (1990).
66. Z. Kong, K. L. Rinehart, R. M. Milberg, W. D. Conway. *J. Liq. Chromatogr. Rel. Technol.* **21**, 65 (1998).
67. H. Kidwell, J. J. Jones, D. E. Games. *Rapid Commun. Mass Spectrom.* **15**, 181 (2001).
68. L. J. Chen, Y. Song, D. E. Games, I. A. Sutherland. *J. Liq. Chromatogr. Rel. Technol.* **28**, 1993 (2003).
69. P. Winterhalter. *Abstracts of Papers of the 4th International Conference on Countercurrent Chromatography* **40** (2006).
70. A. Rasooly, Y. Ito. *J. Liq. Chromatogr. Rel. Technol.* **22**, 1285 (1999).
71. A. Rasooly, Y. Ito. *J. Liq. Chromatogr. Rel. Technol.* **21**, 93 (1998).
72. S. Matsuda, K. Matsudo, Y. Ito. *J. Liq. Chromatogr. Rel. Technol.* **26**, 1135 (2003).
73. Y. Shibusawa, A. Yanagida, Y. Ito, K. Ichihashi, H. Shindo. *J. Chromatogr., A* **886**, 65 (2000).
74. A. Yanagida, A. Shojia, Y. Shibusawaa, H. Shindoa, M. Tagashirab, M. Ikedab, Y. Ito. *J. Chromatogr., A* **1112**, 195 (2006).
75. M. Kurumatani, R. Fujita, M. Tagashira, T. Shoji, T. Kanda, M. Ikeda, A. Shoji, A. Yanagida, Y. Shibusawa, H. Shindo, Y. Ito. *J. Liq. Chromatogr. Rel. Technol.* **28**, 1971 (2005).
76. J. B. Friesen, G. F. Pauli. *J. Agric. Food Chem.* **56**, 19 (2008).
77. K. Shinomiya, N. Inokuchi, J. N. Gnabre, M. Muto, Y. Kabasawa, H. M. Fales, Y. Ito. *J. Chromatogr., A* **724**, 179 (1996).
78. A. Berthod, K. Talabardon. *Quim. Anal.* **16** (Suppl. 2), 197 (1997).
79. A. Berthod. In *Encyclopedia of Environmental Analysis and Remediation*, R. A. Meyers (Ed.), p. 1312, John Wiley, New York (1998).

80. Y. Liu, V. Lopez-Avila, M. Alcaez. *Anal. Chem.* **66**, 4483 (1994).
81. T. A. Maryutina, B. Ya. Spivakov, P. Tschopel. *Fresenius' J. Anal. Chem.* **356**, 430 (1995).
82. V. M. Pukhovskaya, T. A. Maryutina, O. N. Grebneva, N. M. Kuz'min, B. Ya. Spivakov. *Spectrochim. Acta* **48B**, 1365 (1993).
83. V. M. Pukhovskaya, O. N. Grebneva, T. A. Maryutina, N. M. Kuz'min, B. Ya. Spivakov. *Spectrochim. Acta* **50E**, 5 (1995).
84. B. Ya. Spivakov, T. A. Maryutina, V. L. Bashlov, V. M. Pukhovskaya, Yu. A. Zolotov. *Proceedings of 5th Japan–USSR Symposium on Analytical Chemistry, Sendai and Kiryu, Japan*, p. 241 (1990).
85. B. Ya. Spivakov, T. A. Maryutina, Yu. A. Zolotov. *Proceedings of the International Solvent Extraction Conference, Japan*, p. 451, Elsevier, Amsterdam (1992).
86. S. Usuda, H. Abe, S. Tachimori, W. Murayama. *Proceedings of the International Solvent Extraction Conference, Japan*, p. 717, Elsevier, Amsterdam (1992).
87. B. Ya. Spivakov, T. A. Maryutina, P. S. Fedotov, S. N. Ignatova. In *Metal-Ion Separation and Preconcentration. Progress and Opportunities*, ACS Symposium Series No. 716, A. H. Bond, M. L. Dietz, R. D. Rogers (Eds.), chap. 21, p. 333, American Chemical Society, Washington, DC (1999).
88. P. S. Fedotov. *J. Liq. Chromatogr. Rel. Technol.* **25**, 2065 (2002).
89. T. A. Maryutina, B. Ya. Spivakov, L. K. Shpigun, I. V. Pavlenko, Yu. A. Zolotov. *Zh. Anal. Khim.* **45**, 665 (1990).
90. T. Araki, T. Okazawa, Y. Kubo, H. Ando, H. Asai. *J. Liq. Chromatogr.* **11**, 267 (1988).
91. T. Araki, T. Okazawa, Y. Kubo, H. Asai, H. Ando. *J. Liq. Chromatogr.* **11**, 2473 (1988).
92. T. Araki, H. Asai, H. Ando, N. Tanaka, K. Kimata, K. Hosoya, H. Narita. *J. Liq. Chromatogr.* **13**, 3673 (1990).
93. H. Abe, S. Usuda, H. Takeishi, S. Tachimori. *J. Liq. Chromatogr.* **17**, 1821 (1994).
94. S. Usuda, H. Abe, S. Tachimori, W. Muraama. *Proceedings of the International Solvent Extraction Conference, Japan*, p. 717, Elsevier, Amsterdam (1992).
95. H. Abe, S. Usuda, H. Takeishi, S. Tachimori. *J. Liq. Chromatogr.* **16**, 2661 (1993).
96. Q. K. Shang, D. Q. Li, J. X. Qi. *J. Solid State Chem.* (2003).
97. G. Ma. H. Freiser, S. Muralidharan. *Anal. Chem.* **69**, 2835 (1999).
98. H. Hoshi, S. Nakamura, K. Akiba. *J. Liq. Chromatogr. Rel. Technol.* **22**, 1319 (1999).
99. Y. Ito, H. Oka, E. Kitazume, M. Bhatnagar, Y. W. Lee. *J. Liq. Chromatogr.* **13**, 2329 (1990).
100. E. Kitazume, M. Bhatnagar, Y. Ito. *J. Chromatogr.* **538**, 133 (1991).
101. Y. R. Jin, L. Z. Zhang, S. J. Han, L. X. Zhang, J. M. Zhang, G. Q. Zhou, H. B. Dong. *J. Chromatogr., A* **888**, 137 (2000).
102. K. Akiba, H. Hashimoto, S. Nakamura, Y. Saito. *J. Liq. Chromatogr.* **18**, 2723 (1995).
103. S. Namura, H. Hashimoto, K. Akiba, Y. Saito. *Anal. Sci.* **13**, 525 (1997).
104. K. Akiba, H. Hashimoto, S. Nakamura, Y. Saito. *J. Liq. Chromatogr. Rel. Technol.* **20**, 1995 (1997).
105. S. Nakamura, H. Hashimoto, K. Akiba. *J. Chromatogr., A* **789**, 381 (1997).
106. K. Akiba, H. Hashimoto, A. Tsuyoshi, S. Nakamura. *J. Liq. Chromatogr. Rel. Technol.* **22**, 2795 (1999).
107. S. Abbey, F. S. Gladney. *Geostandards Newslett.* **10**, 1 (1986).
108. E. Bauer-Wolf, W. Wegscheider, S. Posch, G. Knapp. *Talanta* **40**, 9 (1993).
109. I. W. Croudace, S. Marshall. *Geostandards Newslett.* **15**, 139 (1991).
110. P. S. Watkins, S. Novan. *Chem. Geol.* **95**, 131 (1992).
111. S. N. Ignatova, T. A. Maryutina, B. Ya. Spivakov, V. K. Karandashev. *Fresenius' J. Anal. Chem.* **370**, 1109 (2001).
112. M. K. Chmutova, T. A. Maryutina, B. Ya. Spivakov, B. F. Myasoedov. *Radiokhimiya* **6**, 56 (1992).

113. M. K. Chmutova. *Proceedings of 3rd Finnish-Russian Symposium on Radiochemistry*, Helsinki, p. 44 (1994).
114. M. K. Chmutova, L. A. Ivanova, G. V. Bodrin, Yu. M. Polikarpov, B. F. Myasoedov. *Radiokhimiya* **38**, 520 (1996).
115. J. F. Wu, Y. R. Jin, Q. H. Xu, S. L. Wang, L. X. Zhang. *Chin. J. Anal. Chem.* **34**, 1311 (2006).
116. H. Hoshi, A. Tsuyoshi, K. Akiba. *J. Radioanal. Nucl. Chem.* **249**, 547 (2001).
117. Y. R. Jin, L. X. Zhang, L. Z. Zhang, S. J. Han. In *Countercurrent Chromatography – the Support-free Liquid Stationary Phase*, Vol. 38, A. Berthod (Ed.), p. 261, Elsevier, Amsterdam (2002).
118. Y. R. Jin, G. Q. Zhou, X. H. Wang, B. Xia, L. Li, J. F. Wu, D. M. Li, L. X. Zhang. *J. Liq. Chromatogr. Rel. Technol.* **26**, 1593 (2003).
119. K. Akiba, H. Hoshi, A. Tsuyoshi. *J. Radioanal. Nucl. Chem.* **246**, 147 (2000).
120. B. S. Mohite, S. M. Khopkar. *Analyst* **112**, 191 (1987).
121. E. Kitazume. In *High-Speed Countercurrent Chromatography*, Y. Ito, W. D. Conway (Eds.), p. 415, John Wiley, Chichester (1996).
122. B. S. Mohite, S. M. Khopkar. *Talanta* **32**, 565 (1985).
123. Y. Surakitbanharn, S. Muralidharan, H. Freiser. *Solvent Extr. Ion Exch.* **19**, 45 (1991).
124. Y. Surakitbanharn, S. Muralidharan, H. Freiser. *Anal. Chem.* **63**, 2642 (1991).
125. T. Wang, Y. Nagaosa. *Anal. Lett.* **36**, 441 (2003).
126. T. Wang, M. Xue, Y. Nagaosa. *J. Liq. Chromatogr. Rel. Technol.* **28**, 2085 (2005).
127. E. Kitazume, N. Sato, Y. Saito, Y. Ito. *Anal. Chem.* **65**, 2225 (1993).
128. E. Kitazume, N. Sato, Y. Ito. *J. Liq. Chromatogr. Rel. Technol.* **21**, 251 (1998).
129. E. Kitazume, T. Higashiyama, N. Sato, M. Kanetomo, T. Tajima, S. Kobayashi, Y. Ito. *Anal. Chem.* **71**, 5515 (1999).
130. E. Kitazume, Y. Takatsuka, N. Sato, Y. Ito. *Abstracts of 2nd International Conference on CCC*, 15–20 April, p. 44, Beijing (2002).
131. P. S. Fedotov, T. A. Maryutina, A. A. Pichugin, B. Ya. Spivakov. *Russ. J. Inorg. Chem.* **38**, 1878 (1993).
132. K. Talabardon, M. Gagean, J. Mermet, A. Berthod. *J. Liq. Chromatogr. Rel. Technol.* **21**, 231 (1998).
133. T. A. Maryutina, B. Ya. Spivakov, P. Tschopel. *Fresenius' J. Anal. Chem.* **356**, 430 (1995).
134. P. Fedotov, D. Thiébaud. *J. Liq. Chromatogr. Rel. Technol.* **23**, 897 (2000).
135. P. S. Fedotov, C. Bauer, P. Popp, R. Wennrich. *J. Chromatogr. A* **1023**, 305 (2004).
136. P. S. Fedotov, A. G. Zavarzina, B. Ya. Spivakov, R. Wennrich, J. Mattusch, P. C. De, K. Titze, V. V. Demin. *J. Environ. Monit.* **4**, 318 (2002).
137. P. S. Fedotov, R. Wennrich, H.-J. Stärk, B. Ya. Spivakov. *J. Environ. Monit.* **7**, 22 (2005).
138. P. S. Fedotov, W. J. Fitz, R. Wennrich, P. Morgenstern, W. W. Wenzel. *Anal. Chim. Acta* **538**, 93 (2005).
139. M. Schreiber, M. Otto, P. S. Fedotov, R. Wennrich. *Chemosphere* **61**, 107 (2005).
140. P. S. Fedotov, B. Ya. Spivakov, V. M. Shkinev. *Anal. Sci.* **16**, 535 (2000).
141. O. N. Katasonova, P. S. Fedotov, B. Ya. Spivakov, M. N. Filippov. *J. Anal. Chem.* **58**, 473 (2003).
142. A. V. Filgueiras, I. Lavilla, C. Bendicho. *J. Environ. Monit.* **4**, 823 (2002).
143. E. V. Thurman, M. S. Mills. *Solid-phase Extraction. Principles and Practics*, Wiley-Interscience, New York (1998).
144. B. Ya. Spivakov, G. I. Malofeeva, O. M. Petrukhin. *Anal. Sci.* **22**, 503 (2006).