

# MOLECULAR EXPLANATION FOR INTELLIGENCE

INCLUDING ITS GROWTH, MAINTENANCE, AND FAILINGS

by  
R. R. Traill

Published online by  
[Brunel University Research Archive \(BURA\)](#), May 2007  
also (in 7 separate files) by Ondwelle Publications, Melbourne, May 2006

Original Title and Details

**THE CYBERNETICS OF CONCEPTS:  
AN INTEGRATED SYSTEM OF POSTULATES TO EXPLAIN THEIR  
NATURE, ORIGINS,  
USE, MALFUNCTION AND MAINTENANCE  
WITHIN A NATURAL NEURAL-MOLECULAR MEDIUM  
IN THE BRAIN**

**Ph.D. thesis**

**Institute of Cybernetics  
Brunel University, UK**

**March 1978**

## CONTENTS

Original  
Thesis-page No  
as shown here  
in the margin

Lists of illustrations and tables	8
Acknowledgements	10
Declaration concerning publication	11
Original Summary of Whole Work	12
<b>GENERAL INTRODUCTION</b>	<b>15</b>
Problems of intuitive thought — as a tool, and as a subject of study	15
Subtopics and how they are allocated here	20
The balance between Parts A, B, and C — and their interdependence	21
Some 18 interrelated biological insights which seem mutually corroborative	22
Possible applications in the social sciences and elsewhere	28
(1) The psychology of economics and politics; (2) Psychiatry; (3) Philosophical enigmas; (4) Academic psychology; (5) Physiology; (6) Embryology and cell-navigation; (7) Demystification within physics	
<b>PREFACE TO THE 2006 ONLINE EDITION</b>	“37a”
References for the 2006 Preface	

**PART A. EXTENDING PIAGETIAN PRINCIPLES OF LEARNING:**  
The framework for a comprehensive model of the real biological brain and its full unrestricted learning-capability, in natural conditions

Original  
Journal-page No  
as shown here  
in the margin

<b>ACQUISITION OF KNOWLEDGE WITHOUT TRANSCENDENTAL ASSISTANCE:</b>	
<b>AN EXTENDED PIAGETIAN APPROACH — <i>Kybernetes</i>, 5, 73-82</b>	<b>73</b>
<b>(A1) A Dissection of Piaget’s Key Concepts</b>	<b>73</b>
A1.1 Introduction: Should we postulate specific mental mechanisms in the absence of clearcut evidence?	73c1
A1.2 Popper’s concept of Mental Versus Physical	74c1
A1.3 Similar concepts in Piaget ’s Work	75c1
A1.4 Application and extension	75c2
(i) Reflexes.	
(ii) Classical Conditioning.	
(iii) Operant Conditioning.	
(iv) Innate Releasing Mechanisms (IRMs) and Fixed Action Patterns (FAPs).	
A1.5 Application to Piaget’s theory itself	77c2
A1.6 An orthodox summary of Piaget ’s stages	80c2
<b>(A2) Truth and Operationalism:</b>	
<b>the epistemology of social systems such as the scientific community</b>	<b>81</b>
<b>(A3) ANALYTICAL THEORY OF SENSORI-MOTOR</b>	
<b>SPATIAL DEVELOPMENT — <i>Kybernetes</i>, 7, 61-71</b>	<b>61</b>
A3. 1 Introduction and Resumé	61c1
A3. 2 The Nature of Hereditary Schemoids	62c1
A3. 3 Calling the labels of schemoid “tapes” which are physically remote: Technical considerations	63c1
A3. 4 Schemes, and Piaget’s first two sensori-motor stages	63c2
A3. 5 Taking liberties with the rigidity of mathematical groups	65c2
A3. 6 The practical mathematical achievements of evolution and heredity	66c2
A3. 7 The practical mathematical achievements of stage 1 (manifested at stage 2)	67c2
A3. 8 Achievements during stage 2	68c1
A3. 9 Stages 3 and 4 (approximately)	68c2
A3. 10 Stages 5 and 6 (approximately)	69c2
A3. 11 Subsequent recapitulation (recursion)	70c2
A3. 12 Summary and Conclusion	70c2

**PART B. FUNDAMENTAL NATURAL STRUCTURE AND MECHANISM:**  
 Developing feasible micro-structural detail to account for the actual behavioural repertoire encoded within a brain — given the general framework developed in Part A

*See separate online document:*  
[23Hwww.ondwelle.com/MolecMemIR.pdf](http://23Hwww.ondwelle.com/MolecMemIR.pdf)

page Nos  
 in separate  
 online  
 document  
 ↓

**TOWARD A THEORETICAL EXPLANATION OF ELECTRO-CHEMICAL INTERACTION IN MEMORY USE:**

	<b>THE POSTULATED ROLE OF INFRA-RED COMPONENTS AND MOLECULAR EVOLUTION</b>	<b>(3)</b>
	Forward — Online Edition (2006) of “Part B”	(3)
	2006 References	
	Original Abstract	(5)
	Basic Electromagnetic Symbols and Co-Axial Formulae	(6)
	(B1) Introduction: the search for a rigorous structural theory of memory	(7)
	(B2) How could bio-electrical messages be converted into meaningful and specific chemical coding — and be retrieved?	(10)
	B2.1 a special role for infra-red?	(10)
	B2.2 Specific patterns of sub-picosecond events as triggering stimuli	(11)
	B2.3 Emission and reception of selective signals within the infra-red range.	(12)
	B2.4 The apparent enigma of how experience might be chemically ‘written down’ — and a new solution made feasible if memory elements are molecular rather than only neural-synaptic.	(16)
4	(B3) Transmission properties for various frequencies of electromagnetic signal within nervous tissue, and the special case of saltatory conduction	(19)
	B3.1 a different evaluation in terms of the geometry and physics of tissues	(19)
	B3.2 Some basic points concerning electrical theory	(19)
	B3.3 Possible boundary reflecting-layers: their nature and implications	(20)
	B3.4 Transmission possibilities for a co-axial cable of myelin in direct contact with homogeneous aqueous solutions	(22)
	B3.5 Summary of basic transmission characteristics expected in nerve-fibres — on theoretical grounds	(24)
	(B4) The second-lowest mode of transmission in co-axial myelin ( $H_{1,0}$ ): optical dispersion of infra-red	(25)
	(B5) Evolution of communication methods: suggested extensions to Bishop’s two stages	(28)
	(B6) Other related architecture in brief: glia, paranodal regions, and cell-body interior	(30)
	References (for Part B only)	(31)

**PART C. DEVELOPMENT AND APPLICATION:**  
 Developing the hypothetical concepts more deeply — and applying them to explain a number of poorly understood psychological phenomena, including dysfunctions of the system which result in clinical neurosis or psychosis.

Original  
 Thesis-page No  
 as shown here  
 in the margin  
 ↓

**A MOLECULAR THEORY OF BRAIN ORGANIZATION,  
 WITH EXPLANATIONS OF NEUROSI, PSYCHOSIS, AND NORMAL FUNCTIONING**

	(C1) A Broader Strategy for Research — seeking coherence amongst well-defined elements	137
	C1.1 Observability and experimental testability	137
	C1.2 Induction, deduction, and internal testability	142
	C1.3 Discrete modelling of “continuous” reality	144
	C1.4 Apparently-continuous modelling of apparently-continuous reality: “Scientific Impressionism”	147

(C2) A Brief Review of the Neo-Piagetian Linear-Molecule Theory of Brain-Function	150
C2.1 The fundamental physical basis	150
C2.2 Learning and the sensori-motor period	152
C2.3 Internal reference ‘by name’: sleep, mathematical sets, and the “ <b>m<sup>n</sup>I</b> ” hierarchy; — implications for decision-making behaviour	155
C2.4 Trend toward mathematical groups in the later sensori-motor period	162
(C3) Abstractions, or Thoughts about Thought-Constructs: Is the Process Recursive ?	165
C3.1 The concept of mathematical recursion, and some variations on this theme	165
C3.2 Estimating the likely scope and nature of recursion in the brain	169
(C4) Ashby’s Adaptive Brainlike Mechanisms — but with added Self-organization	174
C4.1 Evolutionary pressure toward self-organizing systems	174
C4.2 The trivial cases of unstable and metastable systems	174
C4.3 Inanimate stability and stereotyped “responses” to “stimuli”	175
C4.4 Systems able to switch to alternative response patterns	177
C4.5 Purposeful switching to alternative response patterns	181
(C5) Toward Fully Self-Organizing Versions of Ashby’s Systems, Using Populations of ‘Linear Micro-Elements’	186
C5.1 Some acknowledged defects in Ashby’s exposition	186
Ashby’s first two self-criticisms — problems potentially solved in the above discussion	
Ashby’s third self-criticism — What generates the “gating mechanisms”?	
Not-yet-resolved aspects of the problem which now require deeper investigation	
C5.2 Exploring details of linear micro-element versions of such mechanisms	191
Synchronization and specificity of elements	
Stability of element-ensembles	
The formation of meaningful ensembles	
Practical procedures for establishing ensemble-“lists” — each with its consistent criterion	
A likely topic-segregation role for cell-membranes (and other brain subdivisions)	
C5.3 Embryological considerations, and their relation to the extensive definition of linear micro-element sets	204
C5.4 Concept-structure types within each level:	
another digression in preparation for clarifying Ashby’s difficulties	207
The Neo-Piagetian approach to Ashby’s third problem	
On fitting the Ashby and Neo-Piagetian models together	
Adding a third component — the coexisting “Textbook Synapse-and-Action-potential” account	
Extending Piaget’s ideas into the more elementary domain — (pre-sensorimotor: <b>M<sup>n</sup>L</b> )	
Other thoughts about mental hierarchies	
C5.5 Completing the review of defects in Ashby’s exposition (as listed by him)	222
Applying the above discussion to Ashby’s third problem — on explaining gating-mechanisms	
Ashby’s fourth problem — maintaining a balance between parts of the system	
Ashby’s fifth problem — Which <b>M<sup>n</sup>L</b> level should receive which input? — A topic for Chapt.C6	
(C6) The System Looked at as a Whole, and some Inherent Weaknesses to be Expected	231
C6.1 When should it be feasible to mount a frontal reductionist attack on the perennial problems of psychology? — including such intangibles as Attention, “Mental Energy”, Ego, and Morale	231
C6.2 Consolidating the functional principles of the current model — constraints and hierarchies	236
C6.3 On modelling Attention, Ego, Consciousness, and Superego	242
C6.4 More about the likely hierarchical organization of concepts: parallel systems, inversions of control, and consciousness again	263
C6.5 Distinguishing inputs and acquiring a conceptual hierarchy; success, failure, and the shadow of psychosis	269
C6.6 Dreaming, sleep, and sleep-modes	284
C6.7 Bio-energetics and Pharmacology: Freudian “Mental Energy”	293
(C7) Mechanisms for Neuroses	316
C7.1 What are the “normal” adaptive responses to frustration ?	316
Coping with frustration — good homespun advice, and beyond	
Mechanics of changing one’s frustration-reduction strategy	
C7.2 Denial as “hallucinatory wish-fulfilment” for some part of the situation	319
Denial, fiction, and ego-protection	
Denial versus evidence	
“Freudian energy” needed to maintain the denial	

	C7.3 Projection and introjection as by-products of the self-organization of the ego	321
	Ego — the formation of a very specialized schema	
	Loose mind-metaphor terminology — versus clear (more testable) statements	
	Seeking to explain projection etc. via set-dynamics — hence via molecular dynamics	
	C7.4 Repression as an internally-directed equivalent of denial	323
	C7.5 Other defense mechanisms: — Isolation, Reaction-formation, Undoing, and Regression	325
	Isolation — using higher M <sup>P</sup> L mental activity?	
	Reaction formation	
	Undoing	
	Regression	
	C7.6 Toward a structural definition of neurosis — and of psychosis	331
	“Countervailing forces” — How plausible are they in Reaction Formation?	
	Psychosis, and how it probably differs structurally from neurosis	
	C7.7 Paranoia as a neurosis which may be one cause of psychosis, and therefore often exhibiting aspects of both	336
7	(C8) Developing a Consistent and Reasonably Comprehensive Structural Theory of Psychosis	340
	C8.1 A closer look at the likely mechanisms whereby implicit “intensive” sets might become organized into the two-or-more types of extensive set	340
	“Intensive” for description, “Extensive” for boxes and leashes — a reminder	
	Practical set-defining Systems?	
	Some biological considerations, and multi-choice possibilities	
	Molecule-like list-codes	
	What could hold the mental list-elements together?	
	Evolution sequence: Association → Salient member → Label-for-whole	
	Probability and Stepwise Evolution	
	Rival “a-masters” as a possible factor in psychosis	
	Other Set-Definition Methods — (beyond Intensive and Tethered-extensive)	
	Sets Defined by Barriers such as Cell Membranes	
	Spontaneous Clumping and its Interaction with Boundaries	
	Consolidation into LTM, and its Breakdown in Psychosis	
	Symptoms varying greatly according to which “M <sup>P</sup> L”-level fails	
	Addressing the correct M <sup>P</sup> L in Daily Life — an important skill	
	Summarizing Section C8.1	
	C8.2 Interpretations of Clinical Schizophrenias and Other Conditions, on the Basis of this Theory	377
	(1) Faulty clusterings of concepts.	
	(2) Shakow’s Major and Minor Set, and his anomalous “Preparatory Interval” experiments.	
	Reaction speed, apparently depending on facility in handling mathematical sets	
	Two types of time estimate, with crossover at about 7 sec — implications in set-manipulation	
	(3) Loss of Abstract Thought and Logic.	
	(4) Loss of Volition or Conscious Control.	
	(5) A Negativistic Attitude, or Paranoid Tendencies.	
	C8.3 Some Comments on the Accepted Dimensions for Classifying schizophrenias and Related Conditions	408
	Process/Reactive	
	Hebephrenic/Paranoid	
	Acute/Chronic	
	Public/Private	
	Open/Closed	
	Attention focus	
	In closing	
	C8.4 Aetiological Issues: By what mechanisms are Psychoses likely to Originate?	426
	Drugs.	
	Brain Damage.	
	Sleep Deprivation.	
	Sensory Deprivation.	
	Incidental Minor	
	Perception manipulation	
	Genetic Factors promoting Schizophrenia.	
	Schizogenic Environmental Conditions.	
	C8.5 Which Direction For Future Research?	439
	References	441

**List of Illustrations in Part B — which is located in the separate online document:**

[www.ondwelle.com/MolecMemIR.pdf](http://www.ondwelle.com/MolecMemIR.pdf) or else [www.wbabin.net/physics/trail8](http://www.wbabin.net/physics/trail8) (same).

Figure	Brief Description	Page — according to edition:		
		Printed: '77,'80	Thesis: 1978b	Online: 2006
B2.3/1	A possible basis for signal emission from a population of linear molecules	15	101	13
B2.3/2	Two possible bases for selective signal-reception by linear molecules	19	105	15
B4/1	The three-dimensional <b>E</b> and <b>H</b> fields for the $H_{1,0}$ transmission mode in a coaxial cable	38	124	25
B4/2	Propagation characteristics for nerve-fibres using the $H_{1,0}$ vibrational mode, (theoretical)	40-1	126-7	27

**List of Illustrations in Part C**

Figure	Brief Description	“Page” (in margin)
C4.3/1	Ashby’s simple unmodifiable Stimulus-Response system	176
C4.4/1	Ashby’s “ultra-stable” system	179
C4.4/2	A suggested linear-molecule basis for an “ultra-stable” system	180
C4.5/1	Ashby’s “accumulator of adaptations”	183
C4.5/2	Ditto, but re-interpreted to emphasize recursive implications	184
C5.2/1	Supposed “anatomy” of a linear micro-element	192
C5.2/2	Supportive crossfeed to give synchrony between elements	193
C5.2/3	“Higher level” element, giving a physical encoding of a (mathematical) set	200
C5.2/4	Another suggestion for set-structure encoding	201
C6.3/1	Cognitive-dissonance triangle	253
C6.3/2	Increasingly corroborative cognitive topologies	258
C6.7/1	Examples of uniform wave-guides	296
C6.7/2	Examples of non-uniform wave-guides	297
C6.7/2a	How “the same” shaped-signal can pass through a continuous “translation” process	“305”
C6.7/3	Possible molecular “and-gate”	308
C6.7/4	Possible molecular “or-gate”	309
C6.7/5	Possible molecular embodiment of “ <i>A and not B</i> ” (also entailing an “undischarged energy” problem)	310
C6.7/6	Possible molecular embodiment of “ <i>B and not A</i> ”	311
C8.1/1	Sub-populations of elementary associations (assuming simple closed-loop topologies)	342
C8.1/2	Ditto (but also allowing unclosed strings)	342
C8.1/3	Interpretation of behavioural association-strengths in these micro terms	342
C8.1/4	Yet another suggested structure for encoding of a (mathematical) set	347
C8.1/5	A syncretic extensively-defined set	354
C8.1/6	Possible specialization of one syncretic element, giving a master-element for that set	355
C8.1/7	Idealized intersection of two range-specific spherical shells	360
C8.2/1	Rodnick and Shakow’s “Preparatory Interval” graph — (re-interpreted for this 2006 edition)	390

## List of Main Tables

Figure	Brief Description	Page — according to edition:		
		Printed: pre-1981	Thesis: 1978b	Online: 2006
A3.2/I	The hereditary tendency to match “suitable” response-reflexes to particular stimulus patterns	62*	66	“62”†
B (symbols)	Basic Electromagnetic Symbols and Co-axial Formulae — [see above hyperlinks]	2	14	6
B2.2/I	Absorption-bands likely to be relevant to chemical signal storage and retrieval in the brain	12	98	11
C5.4/I	Postulated M <sup>n</sup> L hierarchical organization for micro-structures within the brain	—	221	“221”†

\* Original printed version of “chapter A3”: — Traill (1978a): *Kybernetes*, 7, 61.71.

† Using the original page-numbers, as shown in the margin of this online text.

## Acknowledgements

I am indebted to Prof.F.H.George and to Prof.T.E.Gambling for their encouragement and support during various stages of this extended project. I would also like to express my gratitude to Dr.A.Sloman, and to Prof.H.G.Furth and his students at Sussex University, for useful discussion relating to Chapter A1; and to Dr.N.E.Wetherick and Ms.Sherrill Hallmond for critically reading the draft of Chapter A3.

Concerning Part B: — I am indebted to Prof.H.A.Gebbie, Prof.W.I.McDonald, and Prof.T.F.Slater for useful discussion and suggestions; and to Mr.H.A.J.Barrett, Dr.R.C.Elliott, Prof.G.S.Brindley, and Prof.L.Wolpert for critically reading various drafts.

Several chapters of Part C were written while I was engaged as a Research Fellow on an SSRC project at Birmingham University. The topic of this project (covering the validation of models of human behaviour) provided me with many helpful insights for my own research.

Finally I am also indebted to Dr.N.Berovic and Dr.G.Nyberg for their helpful discussions and criticism concerning quantum phenomena within molecules; but any errors or heresies are, of course, my own.

## Declaration concerning publication

Part A of this work was published in the journal *Kybernetes*: Chapters A1 and A2 as Traill (1976a), and Chapter A3 as Traill (1978a). This journal was, in the 1970s, published by:- Thales Publications (W.O.) Ltd., 6 Old Bond Street, London W1X-3TA.

Part B has been publicly available as a Departmental Monograph, (Traill, 1977), since December 1977.

### Status of Part B — in 2006

“Part B” became separately available online in February 2006 on two websites: — *i.e.* as [www.ondwelle.com/MolecMemIR.pdf](http://www.ondwelle.com/MolecMemIR.pdf) and also [www.wbabin.net/physics/trail18.pdf](http://www.wbabin.net/physics/trail18.pdf) (same). Accordingly it has been omitted from this present already-oversized document. In any case the here-remaining text is reasonably self-contained without it, given the resumés within Part C.

For Section-headings of the omitted parts, see the Table of Contents, above — or see the *chapter-summaries* immediately following Part A.

## Chapter "0"

(Summary &amp; introduction to 1978 Thesis, Brunel University)

**ORIGINAL SUMMARY of WHOLE WORK**

12

Behaviourists and Logical Positivists commendably set out to purge loose prejudiced arguments from science; but where it is obvious that there remains some sort of "ghost" in their rational "machine", it is self-defeating simply to ignore its existence. Freud, Piaget, and the ethologists have made some progress in grasping this nettle — moving towards a material explanation of the "other-worldly" properties of the individual — but their models of the individual remain nebulously structured in their basic elements. Consequently such theories remain disturbingly controversial, and circumscribed in their applicability.

The present work accordingly sets out to bridge this gap by postulating plausible functions for the existing micro-structure which could account both for observed behavioural phenomena, and for many of the existing vaguer theoretical constructs. Part A develops such an explanation for Piagetian constructs, while Part B fills in some of the technical details concerning quantitative problems of signal generation, transmission, and selective reception.

Part C applies these notions to other non-Piagetian descriptions and interpretations of psychological phenomena, thereby offering an integration and reconciliation of various schools of theory. (Major areas considered include Ashby's "homeostat" approach, biological self-organization, sleep-modes and dreaming, Freudian theories of neuroses, and various theories concerning psychosis). The basic theory itself is meanwhile developed in much greater detail.

A recurring theme throughout the work is the notion that knowledge-acquisition by any independent system depends not only on "external" interaction with the "real" world, but *also* on an active seeking for internal consistency within the resulting "internal" model. This concept is crucial to the study in two ways:- (i) The operation of the brain-systems being considered, and (ii) As a guide to the methodology <12> of the present study itself — in an area where experimental data is uncomfortably sparse, and likely to remain so. <13>

13

**GENERAL INTRODUCTION**

15

This work constitutes a many-angled attack on some of the age-old questions on what important transactions could be taking place inside the structure of the human brain. This is a tall order of course, and time will tell whether the theories proposed are more, or less, correct. But either way, I believe that this work has much to offer in the number of unquestioned (or seldom-questioned) assumptions which it brings to light. If my own solutions to the resulting problems should happen to be somewhat wide of the mark, this will be comparatively unimportant as long as the raising of the questions leads to further investigations and better answers.

**Problems of intuitive thought — as a tool, and as a subject of study**

The following simplistic resumé might perhaps orient the reader to the sort of approach being attempted here in relation to the understanding of the mind/brain, and the relation this work has to other previous ideas on the subject.

Let us start by differentiating between two types of thought process: *Intuitive-subjective* versus *logical*, [or Freudian primary versus secondary-process thinking, or Piaget's Concrete Operations versus Formal Operations; or "M<sup>1</sup>L" versus "M<sup>2</sup>L" in the present work]. We may next consider that these two categories of thought, however we choose to define the difference, will manifest themselves in two relevant ways: (i) as an *object of study* — typically in other



people including patients, but also in “ourselves-at-other-times”, and in non-human animals; (ii) as the very *process* by which we engage in all such consideration. <15>

16

Accordingly, this means that we can *think about Logical thought* (a) mystically, in an intuitive way, or (b) in a logical way; and similarly we may think about Intuitive thought in (c) an intuitive way, or else (d) in a logical way. Thus:-

		Process by which the study is made	
		intuitive thought and feelings	logical or systematic thought
object of study	intuitive thought and feelings	(c) Novelists, Artists.	(d) (?Freud)
	logical or systematic thought	(a) Mystics, Animists, Teleologists.	(b) Bertrand Russell; Logical Positivists.

} both important

— though to what extent these various analyses have so far produced helpful results, remains as a matter for debate.

Probably all such studies must *start* with an intuitive unsystematic approach like those on the left, and many problems might indeed forever defy any really systematic approach. Nevertheless, systematization is the aim for scientific treatments like the present work, so the right-hand items (b and d) call for further comment here:-

(b) One great achievement of Western thought has been the comparative rigour of its logical formulations. This has led to the hope that *absolute* rigour might be achieved, and this hope seems to have been the driving force behind logical positivism and other work related to it: Whitehead and Russell (1910-1913), Carnap (1928), and arguably also Wittgenstein’s “Tractatus” (1921). In the event, such absolute rigour has turned out to be unattainable, as shown in effect by Gödel (1931), and as we may also see fairly easily if we ask ourselves “What is the *logical* justification for our rules of <16> logic?”! The question then becomes one of finding out how we are to achieve good approximations to this ideal — a task tackled in their different ways by Popper, Piaget, and the later work of Wittgenstein.

17

(d) The equivalent study of intuitive or “non-rational” thought has been very much a neglected area, comparatively speaking. But there are two important reasons why we should try to remedy this deficit. Firstly, however much we may take an elitist view deploring the non-rational thought in others (Plato: *The Republic*), it nevertheless abounds all around us and even within our own “rational” selves — and there is no realistic prospect of making any significant change to this situation, as will be apparent from the works of the psychoanalytical schools, and also from the works of Piaget.

Secondly it follows from the inherent limitation of logical thought, just mentioned above, that such “irrational” thought is actually a necessary alternative to fill in the many *inevitable* “holes” in our logic. (In other cases such intuitive judgement may often be *more efficient* for the task in hand even if a logical solution does exist — as many a practical business-man or politician will know from experience). Accordingly, it seems high time that we knew more about such intuitive

processes so that we could plan a better (logical) *utilization* for them, as well as giving us more *understanding* to deal with the “irrational” behaviour of others which was mentioned in the previous paragraph.

As things stand, there is some real justification in the claim that “good novelists are streets ahead of psychologists” in their portrayal of important issues in social life, (item “(c)” in the above table). Freud has, to be sure, done much to put this study <17> of non-rational thought into a rational framework<sup>1</sup>. Unfortunately though, in his day there was no adequate knowledge of neurophysiology on which he could have helpfully based such an attempt (though he did try), so he was forced to “build his house upon the sand” of constructs which were themselves largely intuitive in origin; so his system might best be seen as something of a provisional *semi*-structured model. Now that we know much more about the physical and physiological mechanisms of neural systems, we are in a better position to attempt to re-build “the house” (preferably the same house if possible) — but “on rock” this time.

18

Thus it is that a major purpose of the present project has been to produce some hard-if-controversial explanations for non-rational processes and their vicissitudes — but in more logical and explicit terms than has hitherto been possible. In short, this work aims to make good the felt-weakness of “(d)” in the above table.

In passing, we might notice that the diagonally-opposite entry, item “(a)”, involves an intuitive approach to logical matters! One conspicuous manifestation of this is the occasional anti-intellectual<18> swing against science and logic which becomes fashionable whenever sufficiently vocal sections of the community feel justified in claiming that “the experts have got it all wrong”. Sometimes indeed, they may be correct in their basic criticism — but even if they are, it does not necessarily follow that a straight regression to intuitive “solutions” will help in the slightest. On the contrary, if actually implemented for complex problems, such a doctrine is likely to lead to disaster — to the concentration camp and the gas-chamber, as Bertrand Russell remarked in his influential broadcast comments on D.H.Lawrence. More recently, Professor Max Hamilton’s controversial address to the British Psychological Society (1973) also sounded a similar warning.

19

To abandon ourselves, blindly and totally, to the processes of intuition — without any constraints of level-headed logical thought — would be to abandon ourselves to sub-human barbarity. But to go to the other extreme and deny the necessity and existence of intuitive thought, would be to throw out the baby with the bathwater; and moreover it would probably provoke an eventual reflection from the very same intuitive forces which we were denying. Intuition then is certainly no panacea, but neither can we safely ignore it; and to understand it adequately, it would seem that we should at least try to describe its general operation — in the formal and rigorous language of “logical” thought. And this, of course, brings us back to “(d)” and the objectives of the present work.

It might be fair to say that the important contribution of Logical Positivism was to cause a general progression out of “(a)” and into “(b)”. In retrospect it seems that this programme could

<sup>1</sup> Other writers also deserve a mention here:- Wittgenstein’s later work (1953) poses many apposite questions illustrating the inadequacy of the conventional “logical” approach (and these questions are very interesting to re-read in the light of the current theory), but he himself does not have much to offer in answer to his own questions. Piaget comes nearer to giving an adequate account of sub-rational thought in his various discussions and studies of the Sensori-Motor stage — though it has been suggested that his account lacks the attention to *emotion* which any adequate account of social behaviour should contain (M. Jahoda, 1972, in answer to a question). The present work attempts to produce explanations which are compatible with both Piagetian and Freudian approaches; though to what extent this attempt has been successful is, of course, open to debate. <18>

not actually succeed in fulfilling its own perfectionist ideals, and it is now recognized as being logically false in this strict sense (Ayer, 1978, last column). However Ayer adds, with some <19> justification, “that it was true in spirit, that the attitude was right”. It would now seem that the missing factor was the recognition of the need for the internal-closure criterion of intuitive thought, and the acceptance that this is the only means by which we can “lift ourselves by our own bootstraps” out of the state of complete ignorance that our ultimate protoplasmal ancestors were faced with. Once again, this brings us back to “(d)” — and even to the artist’s insights of “(c)”, whenever more systematic approaches fail.

20

#### Subtopics and how they are allocated here

In broad philosophical terms, it should now be reasonably apparent how this present project relates to previous work. But it is a rather more difficult task to locate its *detailed* arguments alongside those pre-existing in the many interdisciplinary fields involved — simply because of their number and diversity. No proper discussion of such relationship to previous ideas will be attempted at this introductory stage, but these questions have been explored as they arose. Of these, the most important theoretical backgrounds-to-innovation will be found best summarized under the obvious chapter-headings; for example Scientific Method in Chapter C1, and Ashby’s “Homeostat” in Chapter C4. Other less obvious backgrounds to topics within the overall project, are given at least a passing reference as follows:- Classical and operant conditioning, and Ethology (Section A1.4); Neurophysiological saltatory conduction (the latter half of Section B3.3); Embryological mechanisms (Section C5.3); Infra-red and micro-waves in biology (Chapter B1); and the evolution of intra-organism communication (Chapter B5).

[By mid-1978, Parts A and B had already been separately published as ‘hard copy’:

**Part A** in the two *Kybernetes* papers (1976 and 1978, vols 5 and 7); and

**Part B** as a 1977/1980 Brunel University monograph (Cyb.#24), which has now recently appeared online as [www.ondwelle.com/MolecMemIR.pdf](http://www.ondwelle.com/MolecMemIR.pdf) and as [www.wbabin.net/physics/traill8](http://www.wbabin.net/physics/traill8) — (hence its actual text has been omitted here, since the hyperlinks to it seem to suffice). In contrast:

**Part C** had hitherto been publicly available only in university libraries. — RRT, 2006/2007.]

This leads us to a brief consideration of how the overall project report has been divided up. In Part A the discussion has, <20> as much as possible, been kept deliberately abstract — considering what formal functional structures would seem to be needed if the system were to be capable of behaving according to Piaget’s depiction of dynamic human existence and (psychological) development. Having taken this abstract modelling as far as seemed profitable, the study turned to Part B in which it was sought to postulate, in some considerable detail, just what plausible real-physical-mechanisms could underlie the formal abstractions previously postulated. By now this amounted to a promising basic model of the brain and its more straightforward processes. It remained then to elaborate these ideas as much as was feasible, such as to try to develop detailed explanations for more-specialized types of behaviour and experience (notably sleep, neurosis, and psychosis), as a means toward testing the new postulates, developing others relating to fine detail; and meanwhile hoping for practical progress from such innovations. This latter task is dealt with in Part C.

21

#### The balance between Parts A, B, and C — and their interdependence

The size of the field encompassed by the present project is a compromise between two conflicting demands:- (i) The obvious need to stop somewhere and secure any loose ends as best I could, before the whole ensemble of ideas got out of hand; — “to keep it concise” in other words. (ii) On the other hand, given the paucity of direct evidence on the issues raised, it has been necessary to extend the ramifications of the theory as widely as is reasonably possible, so as

to develop whatever information may be gleaned from interdisciplinary cross-comparison (or “internal closure”, to put it into the current theory’s own terminology).

Part A on its own is not particularly convincing. Part B is perhaps a little more compelling as it clearly contains at least <21> three mutually-corroborating arguments and thus has its own self-sustaining share of “internal closure in more than two dimensions”. Nevertheless the new proposed model would be bound to look somewhat hollow if it could not offer an enhanced understanding of the function and malfunction of the mental system as a whole. It has thus been the task of Part C to attempt this application of the basic postulates to the more general theory, and this process needed to be taken far enough either to show up serious weaknesses in the basic postulates, or to constitute a persuasive argument that the theory is at least on the right track.

22

Ideally other disciplines should have been incorporated as well, in all detail which seemed relevant; (e.g. immunology, biochemistry, pharmacology, and experimental embryology). It is with some regret that such aspects have had to be dealt with superficially, or left out altogether. But the line had to be drawn somewhere; and there may even be some advantage in leaving such scope for other, less partizan investigators to cross-check the implications within other, so-far neglected, fields of study.

### Some 18 interrelated biological insights which seem mutually corroborative

The most significant direct theoretical insights offered by the project would appear to be the following. (i) Firstly there is the epistemological challenge to the methodological doctrine that experimental observations are the only legitimate criterion for advancing theoretical models. This clears the way for making progress by other means, depending on the strategy of preferring models according to the degree of uncompartimentalized *internal* consistency which they show; though effective use of this strategy depends on the model being based on elementary entities which are adequately discrete, valid, and predictable-in-principle. (ii) Secondly there <22> is the complementary insight that it seems to be essentially the same strategy which enables biological brains to achieve their extraordinary feats of learning from unsystematic experience (in contrast to the comparatively trivial achievements of so-called “electronic brains”).

23

This comparison gives rise to (iii) — a general observation that similar complex problems are likely to call forth functionally equivalent mechanisms which might or might not be physically equivalent; and of which, one such mechanism might or might not incorporate systems belonging to the other. (Such shared systems could then serve different functional roles with respect to the two different points of view). This, in turn, leads to another consideration: (iv) that a hierarchical “recursive” organization might be successfully evolved within some types of brain system; — an insight which may be regarded as an extension and generalization of Ashby’s concept of the “homeostat”-type of adaptive control, and which thereby offers solutions for his own unsolved list of “antinomies”.

We will turn now to insights as to basic mechanisms:-

(v) There is the general rule-of-thumb that the explanation for any “mysterious” behaviour in a system is often to be found in hitherto unexplored discrete *micro-structure* within a massed *population* of relatively stable units — which are normally observed as a collective whole, giving a misleading appearance of homogeneity and continuous-variation in its properties.

(This notion should not be considered novel, except in its present field of application. There is, after all, ample precedent for it in: the emergence of Chemistry following from the modern concept of atoms and molecules; the emergence of sub-atomic physics; the development of Planck’s postulate to explain anomalies of radiation; Mendel’s abstract concept of the gene — and the subsequent elucidation <23> of this notion; the development of the concept of bacteria from Semmelweiss’s unstructured statistical correlations into the structured and discrete entities

24

of Koch and Pasteur; the advance in neurophysiology when it became possible to isolate the response inside single nerve cells and fibres; and so on into other microbiological developments. It also seems clear that it is our apparent inability to formulate a sufficiently structured view of the individual units within *social* systems, which has left the “social sciences” with a rather dubious reputation for any scientific qualities — so that they are often regarded more as “arts” — and justifiably so. The question of whether there is any feasible remedy for this, must be regarded as a separate issue — to which we will return shortly).

Anyhow, in the present context this has led to a critical re-evaluation of various doctrines about neurophysiological mechanisms;— doctrines which appear to rest on the dubiously-valid criterion of present-day limits to resolution in physiological experiments. (This evidently follows from the self-imposed constraint against seriously considering the existence of mechanisms which cannot be fairly-directly observed). This re-evaluation leads us to further potentially valuable insights:-

(vi) The next is that our phenomenal ability to handle conceptual *sequences*, in a reliably reproducible manner, would be most credibly explained by postulating that the basic encodings of memory will be organized in topologically linear “strings” or “tapes” of physical information-storage; — a formulation which also offers an explanation for the mathematical “sets” and “groups” evident in our thought processes. From there it is but a short step to the plausible supposition (vii) that such linear encodings could be string-like macro-molecules (probably DNA, RNA, or protein) similar to those used for genetic encoding. If this is correct, then the above <24> principle (v: population of micro-elements) may be interpreted as suggesting that practical memory, as displayed behaviourally, will result from cooperative summations from the effects of such micro-elements.

25

(viii) The next insight arose unexpectedly during the investigation of an otherwise unhelpful theoretical idea. The surprise discovery was that, despite physiological doctrines to the contrary, myelinated nerve fibres are constructed in such a way that they could well be suitable media for conducting local infra-red signals through an inhospitable aqueous medium. Then (ix) the very ease with which this infra-red conduction might be aided or blocked by changes at lipid boundaries could act as a powerful means for transducing signals. Furthermore (x) it was seen that such co-axial paths might often favour *optical dispersion* of signals, and that this could actually *assist* the efficient utilization and sorting of signals (contrary to what one might expect from engineering-design practice).

(xi) The next conceptual innovation was to associate this likely *availability* of infrared-handling capabilities with the *need* for such abilities so that there could be proper control of emission and absorption spectra associated with the molecular changes presumably entailed in the chemical storage of memory — and presumably involving the postulated linear molecules.

Then, as a by-product of these considerations, there was (xii) the notion that infra-red or micro-wave interference patterns would offer a more credible means for controlling *embryological* growth than the more usual suggestion of chemotaxis. (This point may turn out to be rather more relevant than would seem at first sight, because it would seem to be rather more testable experimentally than most of the other ideas, and because it might be used to account for the *production* of specific nerve-fibre geometries — as opposed to the <25> functional significance of these shapes).

26

The idea that the fundamental units of memory, for at least some purposes, were of molecular size rather than on the much larger scale of the synaptic junction, opened up a new range of possibilities leading to another insight: (xiii) The vastly greater likely number of such elements (and their much greater speed potential) made it plausible to suggest that all-or-most “recording” of memories actually depended on a vast system of continuing trial-and-error, and that these

arbitrary micro-trials stood a reasonable chance of offering a correct interpretation of events — in amongst the many incorrect interpretations which would normally be promptly rejected as misfits. Such an interpretation seems to go a long way toward explaining the peculiar strengths and weaknesses of biological perception and mentation, as compared with its “counterparts” in modern technology.

(xiv) The next insight is simply a generalization of this concept, to the effect that physically-based Darwinian trial-and-error seems to be the driving-force behind *all* substantial biological progress; and that even our apparently transcendental thought-capabilities operate on fundamentally the same principle as the natural selection of beetles or bacteria; that they might even use the *same* physical mechanisms (though differently controlled in different organs of the body); and that thought processes are simply “evolution writ small”, and involving the same sort of prodigious wastage amongst all but the actual winners.

On the more psychologically-oriented side of the question, these concepts gave a reasonable basis for explaining (xv) how the brain might handle its representation of “sets” (in the mathematical sense) — in a potentially hierarchical way, and with possible recursion in the organization, and even a limited amount of inversion to the hierarchy of control, giving a feedback-loop which could upset <26> the brain’s stability if it were abused by too prominent a utilization. As part of this process, the brain was seen as being involved in continually re-grouping its mechanisms such as to keep alternative methods at its disposal — enabling it to adapt quickly when outside circumstances demand, or when one of the mechanisms fails internally. The development of hierarchical integration was seen as part of this process, and the striving toward the construction of “extensively defined sets” (as physical structures) out of the less-accessible information of “intensively defined sets” was seen as another aspect.

27

The next theoretical innovation was (xvi) to identify the observable *sleep-modes* as outward manifestations of these maintenance and mental-development processes.

Another insight was (xvii) to explain psychoses as a breakdown of these processes in various ways.

To complete the list, (xviii) neurosis was accounted for as trapped-states which were explicable in terms of the physical operation of the linear-encodings of memory; and this suggested ways in which these states might sometimes progress dynamically into a structurally-definable psychotic state.

A concluding remark should be made about the postulated molecular mechanisms. There is no reason to suppose that they in themselves constitute a complete basis for explaining brain function, without also implicating the more macro-phenomena at cell and synapse level. We should rather expect that any reasonably-complete explanation will require a consideration of both, in much the same way that any adequate understanding of the properties of Radium must take account of both its orthodox chemistry, and the sub-atomic characteristics of its nuclei.<27>

### Possible applications in the social sciences and elsewhere

28

There are several important *applications* which might arise from significant progress in this field of what we might call “micro-structural psychology”. There is a clear potential role for such knowledge in clinical psychiatry and as a new ingredient to many aspects of philosophy and academic psychology; and there are less obvious potential by-products from this work in the theoretical domains relating to embryology and other questions of cell-dynamics. Another non-obvious potential application is to the broad field of social psychology — the field which we will now look at first, before discussing the others on the above list:-

(1) *The psychology of economics and politics*. Rather surprisingly perhaps, it was unsolved problems within the social sciences which originally prompted this project, and which seem to

have attracted the most interest more recently. The problem which first seems to have come to me explicitly, was an unease about the way psychological factors were represented within the allegedly quantifiable theories of economics — especially Keynesian economics and the “utility” concept of welfare economics. (These formulations should, for instance, be compared with those of Maslow (1954) — a book which gave me some early insight into the complexities of real human choice criteria). Such economic theories have had their critics within economics, especially since the oil crisis of 1973 (see, for instance: *Monthly Review*, Sep. 1970, Apr 1974; and *Politics & Money*, Apr-Jun, 1974), but to me it was the psychological naiveté of such formulations which seemed most striking.

The reason for this inadequacy was reasonably obvious:-

Although one might well be able to criticize the mathematical models by using well-informed verbal arguments, there seemed to be no way in which these critical insights could themselves be put into any sort of mathematical form, comparable to the existing naive formulae and such that any hard-headed practical planner could use them for <28> deciding optimally about complex economic systems. Consequently, any real-life decisions of this nature had to be made either (a) using the naive models at face-value, or more likely (b) tempering the implications of such models with sober opinion from men-of-experience, who were able to judge the realities of the situation more-or-less accurately — but in a way that they could not fully explain or generalize, and using what we are pleased to call “intuition” or “primary process thinking”. (This non-communicability also clearly leaves scope for antisocial “fudging” of opinions — whether deliberate or not; and this often results in serious distortions of the truth:- in Accounting (Gambling, 1978), and in Politics).

29

This difficulty seemed to suggest that the science of psychology might be able to help, either by explaining the psychological aspects of market behaviour (of consumer, producer, investor, etc.) in adequate detail, or at least by giving us a better understanding of the intuitive processes used to correct the naive models.

Unfortunately psychology itself has hitherto been just about as unsatisfactory in the precision, reliability, and generality of its mathematical models, so there seemed to be little it could offer in practical terms. To be sure, there has often been a symbolic gesture towards using quantitative psychology in public decision-making, but the evidence rather suggests that this use has been no more than a political ploy to support this-or-that decision which has *already been taken in advance* — with the decision-makers *then* casting around for existing arguments to support their case; (Gardner, 1975).

Statistical evidence on social matters often appears contradictory, equivocal, or simply inconclusive or ungeneralizable. And even if it suffers from none of these defects, it still lacks the persuasive <29> power that a structural theory, such as the atomic theory of chemistry, is able to exert. Accordingly it seemed appropriate to seek for a possible solution involving theories which offered a structural approach to explaining thought and brain-activity — rather than mere correlation and factor analysis. This led me to work such as that of Jean Piaget and the ethologists; and the signs are that this was a significant step in the right direction. However, as they stand, the concepts put forward by these writers do not yet measure up to the structural specificity which seemed necessary; so it appeared worthwhile to postulate the type of formal “micro-mechanical” structure which could underlie the phenomena of psychology in general, and those studied by these writers in particular. Hence the formal theories set out in Part A, elaborated physiologically in Part B, and cybernetico-behaviourally in Part C.

30

The original problem then, presented itself as a politico-economic one, but it also seems pertinent to other social problems:- What are the real issues behind censorship of sex or violence for different age-groups? (Correlation studies are costly and inconclusive). What are the real

issues relating to racial equality, intelligence, and ego development? (Issues hotly debated on the basis of orthodox statistical methods). What is the relation between antisocial behaviour of certain social groups, and society's ambivalent treatment of these groups? — and what is the relation of both of these “variables” to the evolution of ego/superego structures within the members of these groups? Will chronic unemployment lead to violent racialism and/or war as it did in the 1930s? — and is there anything we can do to stop it?

Some of these problems will indeed reflect back onto economics in the form of questions such as: •“Exactly why is Mr Q prepared to spend large amounts of money or time on — sending his children <30> to school Y rather than school Z; expensive cars; a political cause; the gambling tables; a mistress; plastic surgery; or whatever?” •“Are some of these non-subsistence buying-tendencies due to an irrational and/or insatiable desire for something else? •What is the something, and is it actually attainable? Would he be better off *not* obtaining it? Is he taking the right actions to get this something anyhow? Is there anything society could or should do to influence him in any relevant way, and why? Is society already creating a problem — for instance by allowing misleading advertising, or other vested-interest activity with undesirable psychological side-effects?”

31

Questions which are more particularly relevant to *management* are:- •“When a worker has ‘job satisfaction’, what is it that is actually happening in his mind, and can we understand this process structurally?” Hence •“Just why is it psychologically important (where possible) to consult workers before acting; and how should this be done?” And hence perhaps •“Just why does Maoist Chinese society continue to spend large amounts of time and energy on consultative meetings of this sort, with apparent enthusiasm, despite the loss of production which this seems to entail, at least in the short term?” (From a cybernetic point of view, any system or custom which *actually* survives the test of time — despite apparent “ineconomies” — is likely to have more significance to it than would appear from casual inspection; and it is therefore likely to be a profitable field for close analysis. Similarly, systems which are surprisingly *unstable* will also be of practical and theoretical interest). [Better examples might include: expensive carnivals, many religious practices, and irrational gambling — RRT 2006].

Other problems, more in the province of the accountant, are:- •“What do we mean by ‘the social cost of unemployment’? And what positive steps are needed for social stability if we are to pursue <31> an overall course of capital-intensive production — making the national labour-force largely redundant?” Or the introspective type of question: •“What is the basis for my intuitive preference for this statistical figure or that? And can I formalize this accounting procedure in such a way as to free myself from political pressure?” (Sterling, 1975; Gambling, 1978).

32

Unfortunately it is probably too early to properly assess what value my current work might be in helping to solve social questions like these, in terms of structured cybernetics. As they stand, these theories about the individual do not, by themselves, have anything much to say on *social* matters without further elaboration — but they may turn out to offer the right sort of framework on which a better, and causally-structured, understanding of social processes might be based. Anyhow that was the original aim of the project and some slight informal investigations along these lines have been initiated elsewhere (Traill, Ref ‘5/77’ [draft only]), even if that part of the task has barely begun.

(2) *Psychiatry*. The most obvious field of likely application for the current theories, especially as developed in the two final chapters, is in clinical psychiatry and the general area of Mental Health. However this does not mean that the new ideas, even if heuristically or epistemologically valid, will necessarily produce any immediate payoff. In the longer term though, we should at least expect to gain some benefit from improved diagnostic criteria and categories, as well as a better understanding of the dynamics of non-static conditions. In addition, after suitable



“research and development”, we might reasonably expect to achieve some helpful progress in the pharmacology of mentally-mediated complaints — thus incidentally narrowing the distinction between “mental” and “physical” conditions.

Preventative measures, education and personality development, <32> and socially-mediated therapy, might also benefit from such understanding — but of course such matters are intimately tied up with the socio-politico-economic systems discussed above as item “(1)”, and worthwhile progress in these fields is unlikely if it is tackled in a piecemeal way, or in the spirit of overconfident infallibility sometimes found amongst social reformers.

33

(3) *Philosophical enigmas*. This work also turns out to have a considerable bearing on many of the unresolved issues traditionally dealt with by philosophers. It seems to me that Sloman (1976, page 16, col. 2) is correct when he writes “If [experimentally] unrefutable theories are to be dubbed ‘metaphysical’, then what I am saying is that even important scientific theories have a metaphysical component, ...”. But then, since the epistemological view promoted here (on a Piagetian basis) is that even the most obvious perceptions and experimental observations must ultimately rest on assumptions which can never be “properly” tested experimentally, it follows that *all* “physical” knowledge is strictly speaking metaphysical! The point need not be laboured here, but the implications are worth pondering, and they certainly support Sloman’s further comment (*ibid.*): “The development of ... ‘metaphysical’ theories is so intimately bound up with the development of science that to insist on a demarcation is to make a trivial semantic point, of no theoretical interest. Moreover, it has bad effects on the training of scientists.”

Other philosophical issues obviously related to the present work are those relating to the concept of “mind”:- Body and mind; Other minds; Personal identity; and Free-will. The main contribution offered here is: the explaining away of many of the obstacles to identifying mind with brain-organization, including questions involving perception, and the “teleological” capabilities of mind.

Freewill perhaps remains more of an enigma. The present work <33> at least offers some clarification of the likely connection between overt behaviour and the *indeterminacy* quantum effects at the level of sub-molecular physics. Many would regard this as vindicating the concept of freewill because of the commonly accepted view that experimental indeterminacy means that the real system itself is inherently fuzzy and undetermined. Although such a view might be misguided, such that in some sense the subatomic structure of the universe *might* actually be predetermined, we can still take some comfort that in practice we will always remain unable to divine the full detail of such predestination. So for all practical purposes we may continue to believe in free will.

34

In the realm of *moral philosophy*, it seems likely that any advance in our understanding of the nature of human feelings and objectives — and the cybernetics of the dynamic systems presumably involved — will give us a better insight into what is entailed in choosing between alternative non-ideal solutions. (This of course is closely related to *jurisprudence* and to the questions of politics and economics mentioned above). Not that we should expect too much in the way of perfect solutions to such imponderable questions, however much progress we might make in understanding them. After all, it may well be that there is no attainable means for reconciling the fundamental requirements of all systems competing within the same environment, and — try as we might — there may be no alternative to having apparently-avoidable suffering occur somewhere or other. It might even be the case that there is no practical way of avoiding some holocaust in which *all* will suffer “needlessly” due to such constraints as informational overload or mental limitation in the face of rapidly moving events; though the better the understanding, the better the chance we will have of foreseeing such disasters and of avoiding them while there is still time — perhaps entailing some <34> painful decisions about whether the

35

ends justify the means, and whether we really know what we are doing with sufficient precision to warrant any drastic action we may see as necessary. How, in other words, can we be reasonably sure that we will not ultimately be surprised by the indirect consequences of our actions?

(4) *Academic psychology*. The contribution that the current ideas may make to *academic psychology* can be summarized briefly:- They offer a new point of departure for experimental studies such as the work on mother-child interaction. They also offer a new point-of-view regarding methodology, in which cybernetic structural-theories are given a status equal to that of experimentation. Last but not least, they give a tangible basis for psychological theories so that students might be saved the unsatisfactory ordeal of trying to cope with essentially unstructured concepts, with the attendant danger of falling into gratuitous mysticism; (see Section A1.1).

(5) *Physiology*. Similar points may be made concerning *physiology*. Here it might well be worthwhile extending experimental investigations such as to take more account of possible phase-related infra-red phenomena and their likely interaction with molecular activity (despite formidable experimental obstacles due to absorption in water). Or more simply we might at least pay more attention to the possible significance of shape and size of nerve-fibres. Here too, there is scope for a greater use of a structured cybernetic approach instead of an overzealous pursuit of experimental purity. Finally there is a trend to mysticism here too, which should not pass unchallenged — even if it should happen to be correct! Professor Eccles<sup>2</sup> might conceivably be correct in suggesting that one's mystical soul resides in some unfathomable way at synaptic junctions, but we would be ill-advised<35> to meekly accept this view while there are still any prospects for more tangible explanations in detailed cybernetic terms. Moreover even at a more down-to-earth level, physiological explanations are not always as rigorous in their basic structural concepts as we might wish, thus leaving the student to accept some detail as an article of faith.

36

(6) *Embryology and cell-navigation*. One unforeseen by-product of the current theory is the potential explanation that it offers for the apparently-purposeful locomotion and growth of cells, and especially the embryological development of tissue-structures into their characteristic shapes. In particular, the likely existence of certain distributions of coherent infra-red frequencies and their presumed interference-patterns could do much to explain why different nerve-fibres tend to develop into one or another of several fairly-well-defined types. Thus it seems possible that a careful analysis of such shapes, sizes, and distributions, might ultimately serve as an unsuspected source of information about embryological mechanisms — even if they should fail to support the (other) hypotheses concerning infra-red signal transmission. Actually though, we might well find that both these topics of interest (embryological development, and functional characteristics) are inextricably interrelated, and that it is through rudimentary *usage* that proper development can take place.

(7) *Demystification within physics*. Finally, another surprising by-product of the current work might turn up within the realm of physics. The perceptive reader might notice certain features of the quantum-explanations which are less specific than we might wish. Without going into detail, we may attribute at least some of this vagueness to the current doctrine in physics that mystery is allowable (or even laudable) within the subatomic domain, provided that this structural ignorance can be by-passed using mathematical abstractions — thus allowing for short-term <36> technological advance, even if at the cost of fundamental understanding. (This ploy has, after all, worked particularly well in *applied* physics — though it is arguable that the imitators of this approach in other applied disciplines have not fared so well).

37

---

<sup>2</sup> Unfortunately I have only encountered this view at second hand, but I presume it is properly expounded in Eccles (1970). [For my later comments see: Traill (1999, Appendix C): *Mind and Micro-mechanism*, Ondwelle: Melbourne: [www.ondwelle.com/BK0\\_MU6.PDF](http://www.ondwelle.com/BK0_MU6.PDF) . — *RRT, 2006*] <35>

The present project, as well as possibly uncovering the need for a re-examination of such principles-of-physics if they are to be applied properly to biology, has also offered an epistemological justification for breaking away from the straightjacket of measurability as *the prime* criterion for respectability — and also offered an accompanying methodological approach whereby this might be done, within any field of study. <37>

"37a"

### PREFACE TO THE 2006 ONLINE EDITION

What has changed in the intervening 28 years since 1978? — Much in some respects, yet little-or-nothing in others. On the one hand, clinical advances in pharmacology have sometimes been quite impressive in dealing with somewhat specialized problems at a practical level; and there have been the notable genome-project findings, with implications raised in “(e)” below.

On the other hand, regarding comprehensive basic theory, I am a little surprised that no-one seems to have yet offered any systematic *rival* suggestions to those developed here, (nor taken the opportunity to re-invented them independently, given their restricted circulation). Indeed I am not aware of *anyone even asking* some of the same questions explicitly, let alone trying to answer them. (E.g. “How is it that we are so good at rapidly handling *sequential* lists and texts, when the traditional neurosynaptic accounts offer no clue to this ability?” — See item (vi), above, on “original page 24” as indicated in the margin.)

Of course, one major problem is the complex interdisciplinary nature of the brain-as-a-system — and that must surely mean that any coherent overall explanation of it must also be both (i) very interdisciplinary, and (ii) at least moderately complex. The present account probably answers that description, so is hardly surprising if even willing individual readers have trouble assimilating it — and *collective* understanding presents a further challenge which is often overlooked, (see below).

I am nevertheless encouraged by a series of promising explanatory by-products (“spinoffs”!) which have developed out of this study, and these suggest that maybe I am doing something right. (I contrast this with theories which are either too vague for them to be extended meaningfully, or which simply petered out through insufficient coherence: like the work of C.L.Hull (1930, etc.).) Anyhow these spinoffs include **(a)** offering a perhaps-plausible solution to the century-old mystery (Donaldson & Hoke, 1905) of what controls the geometry of nerve-fibre cross-sections (Traill, 2000, 2005a); **(b)** Belatedly “umpiring” a flawed 1977 debate on long-distance insect communication, arguing that the available evidence *does* actually point to a solution: modulated-infrared *fluorescence* emitted from pheromones (Traill, 2005c). — Hence a supplementary conclusion from the given “conflicting” evidence (yet to be further investigated): **(c)** that insects may be able to receive modulated infrared *directly* (as such) into their nervous systems, whereas visible-light would have to be processed in the ordinary textbook fashion via action-potentials; (*ibid.*) **(d)** That single-celled animals plausibly use short-range ( $\approx 20\mu\text{m}$ ) infrared signals in lieu of a nervous system, and that this range might be a causal factor in determining cell-size.

Issues less concerned with infrared include: **(e)** arguing (Traill, 2005b) that the new discovery (Mattick 2001, 2003, 2004) that about 97% of the human genome did *not* code for protein, left ample scope for some of the ncRNA (“non coding” RNA) to fulfil the role of Piagetian “schemes” — a possibility which Piaget himself had occasionally hinted at hypothetically, and which seems to coincide very neatly with the “tape” analogy introduced in Part A, here below. Also in connection with that, **(f)** it was possible to further reformulate Piaget’s theories in terms of perhaps-plausible *material* mechanisms (instead of just relying on *abstract* “scheme” concepts as is still the norm in Piagetian literature). — (Traill, 2005b).

Finally, in social psychology, there is the concept **(g)** that *society-and-its-science* is perhaps best seen as a separate learning-being — much more detached from the individuals within it than

one might suppose — and that it makes sense to interpret much of social dynamics in terms of its own separate Sensori-motor and Concrete-operations stages. (One might ask whether it has ever yet achieved a Formal-operations stage!); (Traill, 1999, Ch.4). This approach seems promising for future investigation of various social dysfunctions — usually involving this *society-system*'s tricky interface with individuals in their various roles, but depending far more on Darwinian trial-and-error than we might have expected.

---

Changes in this text itself have been kept to a minimum but in some places (notably sections C6.7 and C8.1) prolific insertions of new dark-blue *subheadings* have been used to assist readability. Likewise some distracting digressions have been consigned to footnotes to get them out of the way. New text and other *amendments* (including any visible punctuation, etc.) are nearly always *identified* by being wholly dark-blue. One exception is for the in-text references in Part A where the changes are inevitable-and-obvious since the original text used *reference-numbers* instead. The other exception is in a small part of section C6.7 (o.pp. 300-303) which has a higher-than-usual density of minor amendments. It thus seemed tidier in some of these cases to flag the alteration by no more than a token colour-change in a few key letters only. (These patches arose largely because of an ambiguity in the meaning of *signal shape*, and it seemed best to clarify the situation whilst maintaining the original text as much as possible).

One new illustration (Fig. C6.7/2a) has been added. Another illustration (Fig. C8.2/1) has been appreciably re-configured — mostly for copyright reasons — but the original may be found in the 1940 paper cited there. For various practical reasons I have retained the original page-numbers as margin-inserts (in dark yellow) — referring to them as “o.p. 300” etc.

Finally, my apologies for usages such as “*he...his*” instead of “*she/he...her/him*” etc.; but of course that is the way one wrote back in the 1970s, and I resist any temptation to pretend otherwise.

R.R.Traill,

Melbourne, May 2006.

### **REFERENCES for the 2006 PREFACE**

- Donaldson, H.H., and G.W.Hoke (1905). “The areas of the axis cylinder and medullary sheath as seen in cross sections of the spinal nerves of vertebrates”. *J.Comp.Neurol.* **15**, 1–.  
[~MU (only v1,11,16+) Ch'0]
- Hull, C.L. (1930). “Knowledge and purpose as habit mechanisms”. *Psychological Review*, **37**, 511-525.
- Mattick, J.S. (2001-11). “Noncoding RNAs: the architects of eukaryotic complexity”. *EMBO Reports* **2**(11), 986-991. <http://emboreports.npgjournals.com/cgi/content/full/2/11/986>  
[#8751 bRNA acq.050303]
- Mattick, J.S. (2003-10?). “Challenging the dogma: The hidden layer of non-protein-coding RNAs on complex organisms” *Bioessays*. **25**, 930-939. [www.imb-jena.de/jcb/journal\\_club/mattick2003.pdf](http://www.imb-jena.de/jcb/journal_club/mattick2003.pdf)  
.  
#8146 -68- bSchem: 031110.html + (dupl:050226.pdf)]
- Mattick, J.S. (2004-Oct). “The hidden genetic program of complex organisms” *Scientific American*. **291**(4), 30-37. [www.sciam.com/article.cfm?articleID=00045BB6-5D49-1150-902F83414B7F4945](http://www.sciam.com/article.cfm?articleID=00045BB6-5D49-1150-902F83414B7F4945) [#8744 040929actu *Dec'sCopy*]

- Traill, R.R. (1988). “The case that mammalian intelligence is based on sub-molecular memory coding and fibre-optic capabilities of myelinated nerve axons”. *Speculations in Science and Technology*. **11**(3), 173-181. [#3062, D4 Ch`11]
- Traill, R.R. (1999). *Mind and Micro-Mechanism: a hunt for the missing theory*. Ondwelle: Melbourne. [www.ondwelle.com/BK0\\_MU6.PDF](http://www.ondwelle.com/BK0_MU6.PDF)
- Traill, R.R. (2000). *Physics and Philosophy of the Mind*. Ondwelle: Melbourne. [www.ondwelle.com/BK1\\_V28.PDF](http://www.ondwelle.com/BK1_V28.PDF)
- Traill, R.R. (2005a). *Strange regularities in the geometry of myelin nerve-insulation — a possible single cause*. Ondwelle: Melbourne. [www.ondwelle.com/OSM01.pdf](http://www.ondwelle.com/OSM01.pdf)  
— Also in *Gen.Sci.J.* [www.wbabin.net/physics/trail4.pdf](http://www.wbabin.net/physics/trail4.pdf)
- Traill, R.R. (2005b). *Thinking by Molecule, Synapse, or both? — From Piaget’s Schema, to the Selecting/Editing of ncRNA*. Ondwelle: Melbourne. [www.ondwelle.com/OSM02.pdf](http://www.ondwelle.com/OSM02.pdf)  
— Also in *Gen.Sci.J.* [www.wbabin.net/physics/trail2.pdf](http://www.wbabin.net/physics/trail2.pdf)
- Traill, R.R. (2005c). *How Popperian positivism killed a good-but-poorly-presented theory — Insect communication by Infrared*. Ondwelle: Melbourne. [www.ondwelle.com/OSM03.pdf](http://www.ondwelle.com/OSM03.pdf)  
— Also in *Gen.Sci.J.* [www.wbabin.net/physics/trail7.pdf](http://www.wbabin.net/physics/trail7.pdf)

## Part A

*ACQUISITION OF KNOWLEDGE WITHOUT TRANSCENDENTAL ASSISTANCE:  
AN EXTENDED PIAGETIAN APPROACH<sup>1</sup>*

**Kybernetes** 1976, Vol. 5, pp. 73-82

© Thales Publications (W.O.) Ltd. — reproduced here by permission

ROBERT R. TRAILL

*Institute of Cybernetics, Brunel University, Uxbridge, Middlesex (U.K.)*

*(Received June 12, 1975)*

[Parts I and II later serving as thesis-chapters A1 and A2 — as follows]

### Chapter A1

— Part I of *Kybernetes* paper ( published 2 years earlier in vol.5)

#### ***A DISSECTION OF PIAGET'S KEY CONCEPTS — (Part I of the *Kybernetes* paper, vol.5)***

73

#### SUMMARY OF CHAPTER

Piaget's basic objective is seen as an attempt to explain how the individual and his evolutionary forbears can collectively gain practical mental-models of the “real world” — starting ultimately from nothing, and without independent assistance.

This paper firstly sets out to clarify Piaget's rather abstract views on this matter by postulating a more detailed mechanistic basis for them, and then interpreting various observations in terms of the hypothetical mechanisms. (This analytical approach is thus primarily intended as a heuristic aid; though it is also shown to be *prima facie* compatible with some other, non-Piagetian paradigms.) It is concluded that a useful way of summarizing the process is in terms of the *combined* operations of preference for “internal closure” within the brain (Internal Coherence or consistency), and preference for “external closure” during interaction with the environment (Pragmatism or experimentation).

In the light of this, Part II briefly discusses the views of Tarski, Popper and the Operationalists/Behaviourists concerning the nature of truth and the legitimacy of reductionism into unobservable domains.

#### ***A1.1 Introduction: Should we Postulate Specific Mental Mechanisms in the Absence of Clearcut Evidence?***

73c1

The work of Jean Piaget and his colleagues at Geneva, is best known amongst psychologists and educationalists, rather than philosophers — at least in the English-speaking academic world. Yet his position is fundamentally philosophical — examining, in considerable depth, various questions relating to knowledge and its acquisition. Moreover, even amongst the educationalists and psychologists who rate his work as important, their interest seems concentrated on the descriptive results of his observations (such as successive stages of intellectual development in children) or his experimental methodology rather than his ideas of the underlying causes — that is to say they are concerned with the *behaviour* of the unknown “black box” rather than the speculation about what is inside it (in line with the behaviourist-operationalist tradition of contemporary science, which we will look at in *Part II*).

The “opaque style” of Piaget's writing is often blamed for the misunderstandings and ignorance of his work, and there is some substance to the charge. But perhaps a more compelling

73c2

explanation can be made in terms of his own theory. To put it simply — in order to *understand* concepts one must, at some stage, tie its elements down to something concrete which can be actually seen and/or handled in various ways; and the relationships between these elements need to be such that we can actively manipulate them — at least in our “mind’s eye”, or better still by physical manipulation.

But in the writings of the Geneva school, the concepts propounded are often presented very abstractly, without the faintest suggestion as to what the underlying physiological mechanisms and entities might be. Actually such scientific caution in published accounts may well have been wise wherever the concepts were necessarily in a state of flux — public acceptance of a primitive formulation might well have ossified the ideas into a comparatively sterile dogma, a not-unknown occurrence in science.

On the other hand, the theory has been so extensively developed by now, that failure to anchor it into some sort of “visualizable” model seems likely to lead the theory into the realm of mysticism rather than science. For one thing, the rather open-ended (and therefore ill-defined) concepts are likely to drift in their meaning from time to time — both in the mind <74:> of the reader, and also in the mind of the writer, as evidenced by the ambiguous meanings such as those identified by Furth 4(1969). Furthermore it has by now become a Herculean task to plough through the extensive literature on the subject, especially as one has to remain alert to shades or abstract meaning; and it seems difficult to avoid this effort if one is to gain any sort of deep understanding of the subject matter. Yet if it were possible to anchor these concepts in something more concrete, it would almost certainly become possible to condense the theory into a more manageable form, as well as rendering it more precise and definable.

Such a sharpening of precision would inevitably mean an increase in *information content*, and therefore *refutability*. In the absence of any further evidence, this information could (according to Popper) be supplied by any hypothesis we liked to make, provided we are prepared to scrap our hypotheses whenever they are found to produce inferences which do not accord with subsequent evidence — or are found to upset the internal coherence in an unacceptable way. Moreover, in practice such a theory<sup>3</sup> may still be found useful after falsification, when there is no other theory of comparable precision or lucidity to replace it — though it would hopefully be reduced in status to that of, say, “a mere heuristic device”. (E.g. the epicycle planetary model did once have quantitative value, even though its detail was structurally false.)

Thus it is that the main purpose of this part of the paper is to suggest some plausible hypotheses about the basic *mechanisms* of mental activity, and use this hypothetical material basis as a medium for re-formulating the principal ideas which the Geneva school have put forward on the genetic epistemology of the individual. But although the discussion will concern itself with material events, it will not be necessary nor desirable at this stage to link these directly with anatomical structure or physiological events — even where these have guided the nature of the hypotheses. Instead, we may make metaphorical use of orthodox paraphernalia of information handling: computer-tape, reports on desks, and such-like.

<sup>3</sup> “Theory” is used here as more-or-less synonymous with the notion of a “concrete model”. The justification for this, in the present context, lies in the idea that a *formal theory* is ultimately anchored in the concrete reality of the real world, and our actions on it (see below).

### A1.2 Popper's Concept of Mental Versus Physical

Let us start by borrowing some basic terms from Popper (1972, Chs 3 & 4)<sup>25:Obj</sup> and pruning his descriptions of them to the bare minimum:

74c2

WORLD 1	WORLD 2	WORLD 3
Physical objects and physical states	States of consciousness	Contents of thought <i>and</i> its representation in writing, tools, etc.

This conceptualization fits in quite conveniently with Piaget's as we shall see, and it is in some ways *more* convenient in view of the linear-ordinal implications of "1, 2, 3" — it is emphasized by both Popper and Piaget that worlds 1 and 3 (as such) can only "intercommunicate" via conscious beings (world 2).

Some other comments are appropriate here. We will generally assume that there is no overlap between these domains, but note that strictly speaking, worlds 2 and 3 are necessarily part of the real world (world 1) — that is unless we are considering a transcendental being (the existence of which I would deny). For the special case in which we are trying to observe, in detail, our own states of consciousness, we can expect to come up against some quite anomalous results<sup>10</sup>(Landsberg & Evans, 1970); but these need not concern us here. Of much more relevance to real life however, is the fact that at least some of world 3 is quite obviously situated in the real world outside our bodies-in the form of libraries, physical models and tools, etc. It would therefore be a matter of interpretation whether someone is using a book (say) as a world 1 "natural" object, or as a world 3 "symbolic" object.

There is no reason why we should not subdivide these domains (as Popper himself concedes) and it would seem useful to divide world 3 according to whether it is within the brain "*world 3i*", or *outside* the brain "*world 3e*". The "*e, i*" notation here tentatively implies that the two sub-domains are, in some sense, operating in parallel.

We may also divide up world 1, and I suggest (using an arbitrary decimal allocation):

*world 1.0* for actual phenomena and objects as they really are,

*world 1.1* for signals which emanate from them,

*world 1.2* for whatever is picked up by the sense organs . . . and so on through the more-or-less automatic pre-processing which is known to occur<sup>8</sup>(Hubel & Wiesel, 1963; <sup>9</sup>Inhelder & Piaget, 1959), until . . .

*world 1.9* the results are dumped, as "progress reports" (in the form of dynamic display summaries rather than written reports) onto the "in-desk(s)" but they rapidly dissolve as further information comes **<75:>** in — except in so far as they attract the attention of "consciousness".

75c1

The decimal notation here implies a serial processing which obviously has a good claim to validity. However, there may well be some feedback between these stages (not to mention possibly large amounts within them), and to this extent our conceptualization will have to be considered as approximate only. This almost certainly applies much more strongly within the consciousness-domain (world 2), so I will not attempt any subdivision of this simple sort for that part of the system.



### A1.3 Similar Concepts in Piaget 's Work

We may now start to clothe this skeleton with Piagetian terminology and concepts, plus any other artefacts which may help to render the ideas more intelligible. The main sources here are Furth <sup>4</sup>(1969) and Piaget and Inhelder <sup>23: MentIm</sup>(Piaget & Inhelder, 1966).

Concerning the *world 1*, and the associated question of information presentation; I do not intend to dwell on the comparatively automatic processes involved in the operation of the senses and the re-organization of information which arises from it. For our immediate purposes it will suffice to say: that distortion will certainly occur (though in a more-or-less predictable manner); that such distortion will often be positively helpful (e.g. in selecting the features most likely to be useful — as determined by evolution of the species); and that the type of distortion can often be varied to some extent according to the whim of the subject (thus selecting what *that individual* has found most likely to be useful, e.g. minimizing the distortion and tending towards objectivity, by a judicious re-integration of distorted impressions).

Let us move on then to the all-important world 2. This is referred to *as thinking or knowing*, and the key concept is the *scheme*,<sup>4</sup> which we may speculatively think of as being made up of a population of identical strips of “computer-tape”, where the replication may be seen as a means towards statistical and graded effects-based on an essentially on-or-off mechanism. Each replica may be thought of as encoding two zones: the first comprising a “label” by which it can be identified if encountered, and thus activated; while the second holds an encoding of a sequence of actions <:> to be followed. We may formally use the term “*tape*” to refer to this hypothetical entity, and use “*label*” and “*program*”<sup>5</sup> for the two zones (partly following computer jargon). The mere *linear* nature of this analogy is quite deliberate, though this does not at all rule out more elaborate functional-complexes as we shall see.

At birth, schemes are prominent in governing reflex behaviours of a fairly stereotyped variety. (There may well be other active schemes, and the uncoordinated movements of the infant could plausibly be attributed to them, but they produce no *organized* manifestations.) Later, however, *modifications* of the existing schemes develop, as also do new superordinate schemes which *call* sequences of the lower-order schemes, like sub-programming in computer practice.

It should be noted though, that the system as here described comprises many “programs” operating in *parallel*, unlike an orthodox digital computer. This implies the need for some sort of stabilizing coordination between those “tapes” actively involved; but such problems have already been encountered for some time in connection with biological growth, so this need come as no surprise. [Indeed the “tape” concept has some obvious micro-biological analogues (such as RNA or protein molecules), but there is no need for us to claim any identity with them at this stage.]

<sup>4</sup> Where *scheme* is not to be confused with *schema* (*plur. schemata*). But note that English texts prior to about 1966-69 have tended to use “schema” for both meanings. (The *schema* will be discussed in §1.5.) In addition it will be convenient to introduce the term *schemoid* to deliberately include both senses, non-committally.

[Note added 2006: Although I still stand by these distinctions, I now doubt the wisdom of trying to use the “*schem...*” words alone to represent these shades of meaning (except in localized linguistic contexts — such as here perhaps). As just noted above, the main problem is that different writers and translators have had different understandings on the word-meanings, and it is now probably too late to reconcile such linguistic divergence. My 2005 suggestion was to depend instead on suitable adjectives to make the necessary distinctions — see Traill (2005b): [www.ondwelle.com/OSM02.pdf](http://www.ondwelle.com/OSM02.pdf) (or .htm) or [www.wbabin.net/physics/trail2.pdf](http://www.wbabin.net/physics/trail2.pdf) — RRT]

<sup>5</sup> Pascual-Leone <sup>15</sup>(1970) following von Uexküll, uses “s” and “r” — stimulus and response — for the scheme *as a whole*; whereas here the scheme has been split into many replicated “tapes” .

### A1.4 Application and Extension

Having looked at the bare fundamentals of the theory, I now propose to dive straight into using it to explain some generally accepted observations of behaviour, introducing further aspects and interpretations of the theory as we go. This seems easier on both reader and writer than the alternative elaboration using more-or-less pure abstractions, with perhaps unfamiliar terminology.

#### (i) Reflexes.

Let us start then with the reflex actions of the new-born, and in particular the “rooting reflex” in which the baby moves its mouth (turns its head) in the direction of a touch on the cheek. We may suppose that the mechanism of this *scheme* works like this: The stimulus is processed and eventually produces a coded internal signal pattern which calls for a particular *label* or range of labels. This call is equivalent to the paging-system of a large organization such as a hospital; and the call-signal itself need <76:> not be completely unambiguous as the specificity could be increased by limiting its distribution to the relevant wing of the hospital.

76c1

The call would, in effect, ask all “tapes” with that label to “report to” a particular control centre<sup>6</sup>-or-mode in order to carry out their particular skill (or “program”). In the simplest case we shall assume that this results in the calling of identical tapes (all having the same program, as well as the same label) until the “control-centre” is full so that any further late-comers are turned away. Meanwhile, those in the “control-centre” collectively put their program into effect-by turning the baby’s head, in this case.

If the stimulus is withdrawn, we may suppose that the “tapes” are ejected from the “control-centre-or-mode” — perhaps to be replaced by a scheme-system for an emotional frustration reaction. This emotional scheme may also be describable in terms of “tapes”, but it need not be assumed that it will follow the same laws in the same detail.

If the head-movement brings the nipple (or finger, or whatever) *into* the mouth, we may expect a similar ejection of the tapes from the control-centre. But this time they will be replaced by a similar set of tapes comprising the next scheme in the adaptive sequence — that for cyclical sucking-actions. (Here we may think of each tape as being re-cycled, at an appropriate phase of the cycle, until it is eventually ejected due to interruption, frustration, or satiation.)

For such goal-seeking procedures in two (or more) dimensions it would be inefficient and cumbersome to have a completely different scheme for every goal-centred radius on which the stimulus might fall; yet clearly a stimulus to the left of the goal would call for a different response from one on the right, or above, or below, etc. It seems likely, therefore, that there will be (say) four different schemes corresponding to such cardinal directions, with labels to match; and any stimulus on an intermediate radius (say at “4 o’clock direction”) will produce a *mixed* call resulting in both Right-Hand and *Below* types of label being called to the control-centre, in the ratio of (say) 2:1.

Subsequent execution of this mixed scheme could take one of two forms: a hybrid action, with the musculature of both programs being called into play simultaneously and more-or-less proportionately. Alternatively we might get an alternation, with the <:> more populous scheme being activated at the expense of the other — but with re-adjustment of the population within the control-centre until the tapes of the first scheme are outvoted by the second, resulting in a switch of policy until the original direction-of-imbalance is restored again, and so on. (It may be

76c2

<sup>6</sup> Cf. Freud's <sub>3</sub>(1917) concept of the preconscious and conscious as *rooms* (p 249). But in view of K. S. Lashley's work on brain-ablations, in the 1920's, and subsequent work, it would be unwise to take this “control centre” as being too literally localized; we should think rather in terms of *communicational proximity*.

significant that the eye-movements of babies start off with a tendency to move horizontally and vertically, rather than obliquely.) In fact, the second alternative is implicit in the first if the “more-or-less proportionate” weighting of the two stimuli turns out to be all-or-none (i.e. Boolean); so clearly one might include near-Boolean decisions as well. This is the sort of thing we would expect if the control-centre’s “inner sanctum” would admit one-or-very-few tapes at a time. And perhaps the set-up also entails some risk that the encumbent tape will be ejected randomly.

(ii) Classical Conditioning.

Next it will be instructive to turn away from Piagetian paradigms to consider the time-honoured case of Pavlovian classical conditioning (Mednick, 1964). If nothing else, this may give us some sort of check on the plausibility of our model.

As a result of evolutionary processes, some types of stimuli are “inherently” rewarding.<sup>7</sup> Certain tastes in the mouth, for instance. Now we very quickly and unknowingly learn whatever other stimuli usually accompany these rewarding stimuli, and thus tend to respond to the new stimuli as if they constituted the original inherent stimulus. The *sight* of food is a case in point, or any other arbitrary neutral stimulus which happens to coincide with the reward — provided the individual can discriminate the stimulus. In fact the newborn infant cannot discriminate the sight of *objects in general* (as we shall see), but a particular tactile stimulus, or a very simple light or sound stimulus would do instead.

A plausible explanation of this, in terms of our “tape” model would be: The two stimuli, occurring more-or-less simultaneously will *both* call representative tapes into the control-centre *together* (though not necessarily into the “inner sanctum”). This physical or communicational proximity may then make possible some sort of cross-reference between those particular tapes actually “within” the control-centre. Let us suppose that some of them will swap labels with each other, like a genetic chromosome cross-over. Subsequently then, any presentation of the *new* stimulus will, in some cases, call forth a tape whose “program” part will cause activity appropriate <77:> to the *original inherent* stimulus. (Whether or not it will also produce similar satiation and emotional effects is something which might be considered as a separate issue).

Anyhow repeated co-presentation of this sort could be expected to increase the effect, especially if there were some sort of weeding out of pairings which were *not* repeated on subsequent occasions (“extinction”). If the repeated learning process were interrupted by a distraction, we might say that the tapes would be ejected (in favour of those of the interrupting stimulus) and furthermore, that they would become dispersed somewhat from easy access to the control-centre, so any resumption of trials would show a drop in effective pairing (“external inhibition”).

If the extinction process (due to a cessation of paired presentation) were considered to take place at a control-centre<sup>8</sup> then the spontaneous recovery during a long rest in the proceedings (“reminiscence”) could be explained as a re-distribution of tape-strips: those from the general population replacing those “near” the control-centre which had been “wiped-out”. Similarly an interruption stimulus during the extinction process (“disinhibition”) would presumably clear the encumbent tapes away from the immediate control-centre, so that when they return, they would have partly replenished their proportion of “conditioned” tapes from the pool of tapes just outside the periphery around the control-centre.

<sup>7</sup> Unless temporarily vetoed due to satiation, or suppressed by an “abnormal” sequence of events (such as genetic mutation or mental trauma) producing conditions which we would describe as “pathological”.

<sup>8</sup> Presumably the same one, though not necessarily.

(iii) Operant Conditioning<sup>9</sup>

In this case, instead of *two stimuli* being presented together and becoming “cross-referenced” to each other, it is arranged that a certain element of *behaviour* (“spontaneously emitted” by the subject) is paired with a significant stimulus. Now from a Piagetian viewpoint, the scheme is the basic world 2 representative of any elementary action or any elementary perceptual coding which gets that far (Furth, 1969, p 138). Thus the operant conditioning paradigm would appear to be little more than a variation on the classical conditioning theme — with a motor-scheme substituted for a sensory-scheme.

## (iv) Innate Releasing Mechanisms (IRMs) and Fixed Action Patterns (FAPs).

These notions of the ethologists look very like congenital schemoids which, in the species concerned, are not amenable to modification by learning — though they may perhaps be incorporated as parts of more general schemoids. Thus a particular pattern of visual cues — such as the sight of an open beak within the nest-may constitute an IRM (so presumably causing a particular “label” to be called) with the consequence that a particular stereo<:>typed sequence of behaviour such as a feeding reaction (a “FAP”) will follow. This FAP is presumably the manifestation of a schemoid,<sup>10</sup> and is therefore (according to the current model) coded as a “program” on an ensemble of identical or interrelated “tapes”.

Congenital walking-reflexes (etc.) in mammals may well be of a similar nature, *but* they are generally amenable to subsequent modification. This may be due to the availability of mechanisms capable of effecting changes, rather than the properties inherent in the schemoid, though both are possible-perhaps in combination.

**A1.5 Application to Piaget's Theory Itself**

We may return now to Piaget's own paradigms and consider how it is that an individual comes to the *hypothesis* that there are such things as reasonably permanent three dimensional “objects” in his environment. Or indeed how it is that the impressions which reach him visually can be *interpreted* as vaguely permanent two-dimensional pseudo-objects (also hypothetical from his point of view).

First let us look carefully at the mathematical concept of “mapping” from one domain to another (the “co-domain”), and the closely related concept of model-building. The nature of this mapping problem depends rather critically on whether we assume a transcendent role or not. [For the traditional Pure-Mathematician there is comparatively little problem. His position seems to be unashamedly transcendental (with respect to his limited universe of discourse — his *detached* “world 1”), so he can juggle meta-mathematical concepts until he has established whatever morphisms his artificial symbolic systems may offer. The position for the *scientist* is rather more debatable as he has to masquerade, for part of the time, as a transcendental being (possessing *episteme*) without strictly being entitled to do so; a point which we will take up again in Part II. As for the contemporary work on *artificial intelligence*, it is not entirely clear where it should be placed. This rather depends on the type of interaction (if any) the computer has with the “real outside world”. But even purely internal computer exercises, with a static (*imitation*) *world 1*, can be immensely complex, even though such problems are arguably similar to those of Pure Mathematics.]

<sup>9</sup> E.g. see <sup>11</sup>Mednick (1964)

<sup>10</sup> Despite the stability displayed, this is probably a scheme (rather than a schema) for reasons to be explained (in terms of genetic replacement) in the second paper of this series <sup>27</sup>(Traill, 1978a: Chapter A3, below).

But we are trying to do without transcendent <78:> observers.<sup>11</sup> The “conscious” observer will, in fact, be confined to world 2 (the co-domain) with no input or knowledge but the distorted, incomplete and *uninterpreted*<sup>12</sup> “reports” on his “in desk”-display. How then is he to set about building his model of the outside world (*world 1.0*)?

Let us be clear about this. Following the Geneva view it would seem that *something* does remain of the Kantian *a priori* knowledge, but this is explicable in evolutionary terms and plausibly consists of: (a) the particular procedures for automatically transforming (i.e. distorting) input information, in a way which tends to be adaptive within the natural limits imposed on it. (b) Basic input stereotypes corresponding to the end products of the perceptual process (e.g. carrying the information that a light/dark boundary is moving across the visual field in a certain direction at a certain speed, <sup>8</sup>(Hubel & Wiesel, 1963) or ethological IRMs). These stereotypes, alone or in combination, may be considered capable of “calling schemoid labels”. (c) A complete basic set of stereotyped action-elements for controlling the musculature and other effectors; these being “callable” by “program elements” within the schemoids. (d) A limited repertoire of preset (but often variable) schemoids serving as the *controlling* basis for hereditary reflexes. Possibly also (e) various schemoids for purely internal ancillary purposes.

Finally, (f) there is the very important propensity of the organism to reach *conceptual equilibrium* (a particular case of physiological equilibrium-seeking or “homeostasis”). This can usefully be thought of here as an effect which selectively supports the retention of those mental *structures* which collectively form a *coherent* whole — a *group* in the mathematical sense of maintaining *closure* when operated on in a particular manner. This means that, provided we stick to a particular set of “operators” (e.g. rotation by multiples of 90° in the plane), the elements (e.g. unit measures directed to North, South, East or West) will *not* produce new elements outside the set when operated upon (i.e. *not NE*, and *not up*, etc.). We may thus think of the structure as being, in some way, self-conservative or permanent — provided that increasing <:> degrees of “groupness” are rewarded by increasing stability.

Thus even though the baby initially knows nothing at all about objects *as such*, nor even that such “permanent things” exist, he nevertheless “tries to make sense” of his encounters with reality by saving up any apparent replications of apparent closure amongst the schemes existing in his world 2. So if the outside world has any closure/coherence at all, it is likely that some of this will be reflected, however imperfectly, in the observer’s world 2; and it is thus open to identification with internally produced group-like structures. Moreover these internal structures will, with any luck, have a group-like structure which is at least something like that of the real world (world 1). With further luck, this structure may be improved on subsequently.

But note that there is no absolute guarantee of success. Of course the more elements we take into account in our mental model simultaneously (capacity and techniques permitting) the more likely that only the *right* solution will really give closure in the model, but we can never be *sure* in an absolute sense. For instance it seems likely that the child’s first (learned) group-structure model of reality is one-dimensional, but models of reality assumed to have this property would not show a very good record of consistency. Similarly two-dimensional models show certain

<sup>11</sup> And this implies that we should also forgo the use of meta-linguistic devices <sup>5</sup>(Gödel, 1931).

Of course, in practice, it is *convenient* to use meta-linguistic concepts, but this implies an artificially limited universe of discourse or (equivalently?) an assumption of axioms (i.e. *episteme* in our present context).

<sup>12</sup> Strictly there is some minimal interpretation, e.g. see <sup>7</sup>Hubel, (1963). But whatever interpretation the observer may have access to, it can have no more absolute truth-justification than his own hypotheses. Such inherited interpretations have arisen through a similar process phylogenetically, by evolution — a *pragmatic* criterion.

disconcerting irregularities when a toy disappears behind a cushion (becoming irreversibly “absorbed into it” from the infant’s viewpoint, as Piaget has suggested). But can we be certain that a three-dimensional model is sufficient? The more mathematically inclined physicists would claim that there are not only four dimensions, but that they all have the same mathematical status (hence the mystical four-dimension concept of interchangeable space-time due to Minkowsky <sup>12</sup>(1908) in 1908, which has kept science-fiction writers busy ever since). Rather less spectacular is the notion that time does constitute a fourth dimension of comparable importance, but that it is qualitatively different; anyhow it would seem that the mind divides the dimensions up in this way — space first, and then time a good deal later, and by a roundabout method <sup>23: MentIm</sup>(Piaget & Inhelder, 1966).

Efforts toward closure/consistency/coherence take place in two directions. On the one hand there is “Formal reflecting abstraction” which takes place within world 2 (though possibly drawing on world 3i). This presumably takes the form of a free exercise of interrelated-scheme systems (especially during “REM” sleep,<sup>13</sup> and generally with motor-correlates <79:> largely suppressed), and it is plausible to suppose that this exercise aids the disintegration or modification of those systems which are seriously lacking in closure (at least as compared with other similar systems). In the same way, our number-system has been revised several times to cope with lack of closure under such reasonable operations as division and taking square-roots.

79c1

The other effort toward closure involves interaction with world 1 (anywhere between *world 1.0* and *world 1.9*). It is fundamental to Piaget’s position that this process of perception is no mere passive taking-in of whatever fate may serve up on the “in-desk” (world 1.9). Such passively accepted “information” has *no meaning* beyond its possible role as an automatic IRM (like a punch-card fed into an ordinary digital computer); and such an activity betokens no intelligence in the sense of the organism being able to develop its own internal “mapping” ability.

Instead, the process will inevitably involve an active exercise of the subject’s own schemoids, either in the form of a participatory intervention in the outside world (such as sucking, or turning), or tracing an outline by visual fixations, or selecting amongst the “reports” which then appear on the “in-desk” (consciously or otherwise). Or indeed any dynamic combination of such interventions.

Let us suppose that at some stage (before birth) the individual’s *world 2* and *world 3i*, taken collectively, contain no structures other than hereditary schemes (and the “tapes” of which they are composed). For some arbitrary reason, a sufficient number of tapes for one of the schemes comes to “wander into the control-centre” and become active. The result — a kick or suchlike. This is then likely to become paired with whatever sensory schemes are active at about the same time, and these will include sense-schemes which have been activated as a *consequence* of the spontaneous action. Here we have the makings of an elementary representation of the *world 1.0*, which from the foetal point of view would be something like this (if it could introspect): “Something, somewhere, echoes back *in response to my thought* — cogito ergo *id est* (mihi)!” [I think, therefore *it exists* (for me at least)].

In other words, the thought/scheme and its associated action *precedes* any subjective awareness of any outside object as such. This formulation starts to explain how it is feasible to set up a “mapping” between the outside world and the thought-domain. It is no use the subject waiting for the outside world to just walk in and present its “map-position” credentials, so to speak. Instead the subject must start off himself with what amounts to a preconceived idea <:> (e.g. that *no* outside world exists), and then see what happens when the idea is applied in practice.

79c2

<sup>13</sup> “Rapid Eye-Movement” sleep; e.g. see Piaget & Inhelder (1966, page xviii)<sup>23: MentIm</sup>.

So we now have an alternative process of testing for closure — between our own mental models and their interaction with the outside world, via senses and actions. This sounds very like Popper’s view (for knowledge at the scientific community level) that one should start with pre-conceived ideas and then test them with a view to scrapping them if they do not give “closure” in the sense just discussed. We shall come back to this point in *Part II*, but I shall just mention in passing that I think he has overemphasized this closure-with-reality at the expense of the first-mentioned type of closure: closure within thought. I would claim that they are about equally important — *except* in the above-mentioned case involving the *first* item of feedback, when the thought domain has (as yet) no artefactual structures to work on, so no basis for closure-seeking within itself.

Before looking at further details relating to the way in which a mental “model” is *constructed* to represent an object, let us first see what is known or conjectured about the *nature* of such a model, once constructed. The Piagetian term for the special case of a two-dimensional model is “image”. This image is not to be confused with any perceptual configuration, so it is quite different from the “image” of optics; but it is the means whereby a child can bring back (into thought) a “representation” of something seen in the past, thus enabling a drawing to be made from memory.

Actually an image appears to be a particular case of a more general type of entity which Piaget and Inhelder choose to call a schema (*schème*). In general then, a schema will be used as a repository of any static canonical configurations<sup>14</sup> which “look like” being of more-or-less permanent value to the individual concerned. (This is suggestive of the concept of Long Term Memory (LTM) which is usually regarded as a separate psychological specialization, e.g. see Wickelgren (1970)<sup>29</sup>).

Initially such schemata are associated with overt action, as in the case (mentioned by Piaget) of a child *opening its mouth imitatively* as a symbolic preliminary in attempting to open a match-box. Gradually however, the overt component (*world 3e*) often dies away leaving an “internalized” symbol (*world 3i*). Just what sort of physical basis such a schema might have is open to question. For the two-dimensional *image* it would probably suffice to postulate a sort of <80:> fossilized scheme — a scheme which had been made immune to modification, but could still be “called” in something-like the usual way, including subsidiary calls to other schemoids as required (also some calls might have affective or “simili-sensory”<sup>15</sup> affiliations, a possibility which may perhaps be denied to ordinary schemes).

Three-dimensional configurations are, however, less amenable to linear-type based mechanism. On the other hand though, it scarcely seems feasible that any general workable Biochemical mechanism could actually be connected into a three-dimensional *physical* structure — yet it is just possible to conceive of a *cross-referenced* call-system of free linear codings such as was postulated above for the schemes themselves. Furthermore, the lattice-structure implicit in such cross-referencing would, in principle, also serve for formal logic systems and presumably other abstract entities as well (e.g. see Inhelder & Piaget’s (1959)<sup>9</sup> “Early Growth of Logic”, p. 273 ff.).

As for the physical location of such *world 3i* symbols, they *might* be located in a separate place away from the schemes of world 2; but there seems no pressing reason why they should, because their respective “domains” could be specified by code or properties rather than by

<sup>14</sup> Two or three-dimensional, or abstract groups of operators, or whatever.

<sup>15</sup> I would prefer the term “provinance” (borrowed from Archaeology), or perhaps “affect-contextual”, but “simili-sensory” is the Piagetian term. Anyhow, whatever it may be called, we appear to be talking about the same phenomenon as that discussed by Penfield (1958, p 31 ff.)<sup>16</sup> when he refers to “feelings of fear or familiarity” (etc.).

position (and it probably would be under such circumstances). Moreover, a separate location might be expected to produce transport and communication problems.

Thus it looks as though it might be fairly simple to explain the formation process for schemata after all. Given that a system of scheme “tapes” has collectively developed a sufficient degree of closure by an “equilibration” process, it seems likely that this success in the closure-test will result in a transmutation of the relevant “tapes”, freezing them into their existing configurations. Indeed it would seem in keeping with chemical and micro-biological systems if this stability of structure were to follow automatically from closure — by some sort of continual dynamic exercise for instance (a concept faintly reminiscent of Hebb’s (1949)<sup>6</sup> “reverberating circuits”, but on a much smaller scale of magnitude than that *implied* by him, though he was careful *not to insist* on any particular physical basis for his theory).

It seems likely that once formed, such schemata are seldom re-dissolved. However with disuse, *referen<:>ces* to such schemata within the schemes of world 2, would tend to be eliminated more-or-less exponentially, so that ultimately the unused schemata would become very difficult to retrieve. The evidence for this is rather varied and circumstantial, including the psychoanalytical concept of barely-retrievable childhood memories, the work on LTM (mentioned above), and Penfield’s (1958, p 31 ff.)<sup>16</sup> neurosurgical probes which might sometimes be interpreted as generating calls to otherwise inaccessible schemata.

80c2

#### A1.6 An Orthodox Summary of Piaget 's Stages

We have now covered those parts of the theory which are most relevant to the arguments in Part II. However, to give some semblance of completion we may look, very sketchily, at the overall stages of development. (There are numerous texts on this *macro-descriptive* aspect of the topic.)

*Approximately (0–2) years*, “sensori-motor”: Lacking schemata (internal symbols) and so lacking a sense of the permanence of objects.

*Approximately (1½–8) years*, “pre-operational”: Symbols for objects and then also for transformations (creating, transforming or destroying objects), but no coordination between them.

*Approximately (7–11) years*, “concrete operations”. New closure systems involving both objects *and* their transformations. New schemes for dealing with basic object- and transformation-schemata are referred to as “operational”. But use of these operational schemes requires the objects to be present (i.e. “concrete”) and perceivable, perhaps because some symbol-handling capacity is fully stretched dealing with *operational* schemata so that there is none spare for handling *object* schemata.

*Approximately (11+) years*, “Formal Operations”. The need for perceptual support for object representation is overcome, opening the way for the disposable-variables of algebraic systems and hypothetical object-relationship systems.

What underlying physical changes are implied by this progression? Several factors come to mind, though there may well be others. Firstly there is some degree of recursion as witnessed by the progression: simple scheme — compound scheme — operational scheme. Then secondly there is the fact that at least some of the underlying physiological capacities develop more-or-less autonomously (“maturation”). Progressive myelination of nerves (from the head down) is perhaps the best documented, but Pascual-Leone (1970)<sup>15</sup> discusses the implications of a likely increase in attention-span with age (equivalent to a growth in the size of <81:> the “control-centre” in the tape-population model discussed above).

Furth (personal communication) raises another consideration: the distinction between learning and non-maturational development. It seems possible that such development (affecting overall outlook in a major way, and occurring in more-or-less discrete steps) is the result of qualitative re-organization of internal closure systems — similar to a phase change in a chemical system — when the stabilizing influences of the old system are overtaken by the influences conducive to stability in the new system.

81  
top



## Chapter A2

**TRUTH AND OPERATIONALISM — (Part II of the *Kybernetes* paper, vol.5)**

## SUMMARY OF CHAPTER

(73)

In the light of the above, Part II briefly discusses the views of Tarski, Popper and the Operationalists/Behaviourists concerning the nature of truth and the legitimacy of reductionism into unobservable domains.

---

“...toute logistique s’appuie sur des présuppositions intuitives: à lire les principaux logisticiens, comme Russell, v. Wittgenstein, Carnap, etc., on s’aperçoit vite qu’ils se réfèrent tous à certaines intuitions tenues par eux comme allant de soi dans la mesure précisément où elles échappent à la vérification logistique.”

81c1

17:Traité (Piaget, 1949, Introduction).

24Conj (Popper, 1963, Ch. 1), following Plato, goes to some pains to distinguish *episteme* (absolute unknowable true knowledge) from *doxa* (fallible but attainable human knowledge). Subsequently 25Obj (Popper, 1972, early chapters) he develops his “three worlds” concept which we have just been using, in which *world 1* presumably embodies *episteme* and *world 3* presumably embodies *doxa*. In this he is encouraged apparently by Tarski’s criterion of truth (*episteme*) as corresponding to reality 25Obj (Popper, 1972: Chs. 8 and 9).

In so far as Tarski’s criterion represents a move away from the operationalist view (that what cannot be observed does not exist, so *episteme* does not exist), then to that extent I share Popper’s enthusiasm for the Tarski formulation. Yet it would seem that Tarski has erred somewhat in the opposite direction. Thus he writes rather disparagingly 26 (Tarski, 1972): “other conceptions and theories of truth are also discussed, such as the pragmatic conception and the coherence theory.” By contrast I would associate these two with the two types of closure attempted by the developing child as discussed in *Part I*; but note that these had to be used *in cooperation*. They would make very little sense taken in isolation, and that is presumably Tarski’s (and Popper’s) quarrel with them.

Tarski continues: “These conceptions seem to be of an exclusively normative character and have little connection with the actual usage of the term ‘true’; none of them has been formulated so far with any degree of clarity and precision.” It is to be hoped that the above condensed version of Piaget’s theory may serve in some way to answer this latter challenge from Tarski. Truth-as-corresponding-to-reality (*episteme*) forms an essential part of the Piagetian system as <:>described here, but there is no absolute guarantee that any mental model which purports to represent reality does so faithfully. This applies to objects,<sup>16</sup> and also (it would appear) to logical and mathematical systems as well.

81c2

Operationalists in Physics and their Behaviourist counterparts in Psychology, seem to make the fundamental *theoretical* mistake of assuming that there is *something* which can be absolutely relied on. Thus *certain types of observation* are taken as infallible because they involve concepts like “object” which are so thoroughly ingrained at a very early age that we take them as valid *a priori*<sup>17</sup>. Similarly *certain types of coherence* in a symbolic model are often assumed to be *a priori* valid because they accord with a “logical schema” which was also so thoroughly ingrained at an early age, that we take it to be an *infallible framework* on which to hang relationships

---

<sup>16</sup> In so far as there *are* such things as real *objects!* See Popper’s discussion 24Conj (1963) of Parmenides; not to mention the wave-particle duality of Modern Physics.

<sup>17</sup> Moreover any IRM-“concepts” would be ingrained even earlier: phylogenetically.

both old and new. (The same point has, of course, also been made about “self-evident” moral laws.)

I suggest therefore that the operationalist *theoretical* standpoint is inconsistent — or at best rests on an arbitrary division of doxa into “*near-enough-to-episteme*” and “*mere guesswork*”. If the Piagetian view of knowledge-acquisition is accepted rigorously, then the consistent operationalist should, it seems, automatically become an agnostic and disclaim any knowledge about anything at all.

But of course, in practice, we must all adopt some sort of criterion of what we are to regard as indubitable. We must impose constraints on ourselves and our thinking or we will get nowhere (as Ashby points out) — and imposing constraint is arguably the purpose of closure-formation. The mistake is not in drawing such arbitrary distinctions, but in believing inflexibly that we have hit on *the* correct place to draw such a distinction, for such a dogmatic belief amounts to <82:> the delusion that we have incontestably acquired some episteme. The cure would seem to be to keep testing closure of both types (empirical and internal coherence) according to some suitable strategy. Just what that strategy should be is open to debate — episteme is denied us here too.

82c1

### ACKNOWLEDGEMENTS (Chapters A1 & A2)

I would like to express my gratitude to Dr. Sloman and to Prof. Furth and his students at Sussex University for useful discussion; and also to Prof. George for his encouragement and support.

*Kybernetes* 1978a, Vol. 7, pp. 61-71  
© Thales Publications (W.O.) Ltd. — reproduced here by permission

ROBERT R. TRAILL  
*Institute of Cybernetics, Brunel University, Uxbridge, Middlesex (U.K.)*  
(Received September 22, 1975)

[then serving as thesis-chapter A3 — as follows]

## Chapter A3

### **ANALYTICAL THEORY OF SENSORI-MOTOR SPATIAL DEVELOPMENT<sup>18</sup>**

61

#### SUMMARY OF CHAPTER

This paper develops more specific details on how natural mental-function might evolve within a wholly-material brain system, depending entirely on “self-organization” operating within a reasonably consistent environment.

It is assumed that mental development can, in principle, be explained in detailed mechanistic terms. The attempt is then made to give the outlines of such an explanation, drawing on existing physiological knowledge, and considerations of the practical “design” difficulties which such a system would necessarily have to face. RNA-like codeable strings are seen as the basic memory elements (rather than adaptable synapses). “Concepts” are explained as Piagetian mental models, built up in explained stages due to interaction with the real object, and encoded on the linear elements.

Coordination between these elements is seen as biochemical but with the added available intermediary of electrically mediated signals, allowing coordination at a distance. The likelihood that subsequent developmental periods may recapitulate the same overall strategy is considered.

#### **A3.1 Introduction**

The general outline of a mechanism to explain Piaget’s theories has been described <sup>23</sup>(Monod & Jacob, 1961; <sup>29:MI2</sup>:Traill, 1975) using basic elements differing substantially from those implied by Hebb <sup>10</sup>.(1949). It is now proposed to explore further the details of this system.

61c1

The previous papers postulated processes whereby Piaget’s schemes and schemata could be encoded by replicated intercommunicating linear micro-objects. These are referred to metaphorically simply as “tapes” or “strings” to avoid prejudging the physical details of their structure; though it may help exposition to think of them tentatively as short RNA strips or suchlike.

Such *scheme-tapes* were envisaged as being generated initially with arbitrary “label” segments, and with blank, empty, or arbitrary “program” segments which could subsequently be altered to something more meaningful. In addition it was supposed that positive or negative segments or tags would be attached to these tapes according to reinforcement contingencies; and on the basis of these tags, the tapes would be preferentially replicated, or dissolved.

<sup>18</sup> This is the second in a series of papers relating to the nature and acquisition of *concepts*, seen as having a material cybernetic embodiment within the brain. The other main papers so-far completed [in 1978] are <sup>28</sup>(Traill, 1976: the above chapters A1-A2 — and <sup>31</sup>.1977: “Part B” whose [hyperlink follows below](#)) respectively.

The program part of each tape was thought of as being made up of a sequence of code-units, and each of these was supposed capable of generating a specific  $\diamond$  code-signal into a control-network, or a limited part of a network. These signals were supposed capable of activating specific “sealed units” of stereotyped effector activity, or else capable of activating other schemes or schemata — thus making feasible “sub-programming,” “cross-referencing” and other departures from strict linear reading of the “list” embodied by a single tape. Effector activity would of course include motor actions, but it also includes internal *modification* of input, and perhaps positive feedback to “hold” the status quo as a mechanism for attention.

61c2

The *senses* were seen as involving lengthy and complex pre-processing, with comparatively unalterable “hardware,” <sup>13:JPhio.</sup>(Hubel & Wiesel, 1962; Iversen, 1974)<sup>18</sup> but with parameters controllable by “modifiers” governed by some of the effector code-signals just described. The end result of this preprocessing would be that a new set of *externally generated* code-signals would then find their way into the control-network, or part of it. These signals were then presumed to activate schemes, schemata or effectors in the same way as internally produced signals. Clearly feedback effects such a tracking could be explained on this basis.

*Schemata* were seen as scheme-like structures which had somehow acquired an inherent stability and were therefore virtually impervious to modification, unlike schemes. It was supposed that they owed this stability to some manifestation of corroboration (i.e. selfconsistency, or “internal closure,” — as if implying that the “idea” inherent in the structure was likely to have permanent value, and was therefore worthy of <62:> storage in Long Term Memory). However internal-closure was not seen as sufficient; there was also the need for “external closure” in the form of predictions of some sort, and some reality-testing of these expectations.

62c1

It is sometimes useful to refer to “scheme-like things” without necessarily distinguishing between schemes and schemata. In such cases the term “schemoid” will be employed. (Note that schemoids are taken to be *populations* of tape-like entities, and are not discrete unique entities as such; though they may be able to coordinate their activities such as to produce discrete unique action patterns.)

### A3.2 The Nature of Hereditary Schemoids

Table I suggests a number of stimulus patterns which might reasonably “call a label,” and a number of likely “sealed unit” effector stereotypes; these are depicted as being already paired-up into workable schemoid tapes. It seems fair to say that each such reflex schemoid starts off as being independent of any *voluntary* control; and furthermore that it has no special affiliation with any other schemoid capable of *reversing* its action, nor a special affiliation with one  $\diamond$  or more schemoids capable of achieving the same basic result in a *different way*. If this is so, then we will need to be able to explain the *development* of such affiliations in order to account for the later acquisition of mental systems with the properties of mathematical “groups.”

62c2

Another noteworthy point is that not all the reflexes are of obvious immediate use to the neonate. Clearly the rooting reflex *does* make immediate sense, and arguably so does the palmar reflex. It is rather less obvious what immediate use the neonate might find for the stepping reflex, though its *later* use can scarcely be denied. This comparison raises some delicate problems of stability: If all these congenital reflexes *are* stable, how do we come to master or eliminate some of them? If they are *not* stable, but amenable to classical and operant conditioning including extinction, then how is it that the stepping reflex comes to survive long enough for the infant to learn to walk?

**TABLE I**

Examples of congenital schemoids and the stimulus patterns likely to cause their activation. The body entries of this table give the probable outcome if the particular action occurs in the particular context; — each such outcome may then be evaluated for its adaptiveness. Thus evolution would favour the adaptive “main diagonal” and tend to leave other entries as “null.” However this could be modified by learning, as in Bruner and Bruner’s experiments 5.(1968) in which *sucking* influenced the focus of the image.

<62>

		CONGENITAL SCHEMOIDS			
		“palmar r eflex” (close hand)	stepping reflex	“rooting r eflex” to the right	shorten focal-length of eyes
STIMULUS PATTERNS (potentially important evolutionarily)	touch palm	likely to grasp object			
	foot touches floor		rudimentary walk-action (approval?)		
	touch right cheek			achieve counsumatory goal (oral)	
	retinal image out of focus				focus onto the object

62  
bottom

As one plausible explanation for this we may attribute the permanence-despite-suppression to the supposed inherited nature of these particular schemoids. Whereas schemata *acquire* their stability and are then difficult to change; these reflex schemoids are seen as infinitely *replaceable* in their original form, from their original genetic source, but readily modi<63:>fiable or suppressable individually once they have been produced. In fact, they would then be just like any ordinary scheme tapes in this respect.

63c1

As a working hypothesis then, let us suppose that the hereditary reflexes are pre-coded on the actual genetic chromosome as DNA coding, and that RNA strips obtained from these sites would either *themselves* constitute ready-made expendable tapes capable of operating collectively as schemes, or else they would be capable of *generating* such tapes in some other physical form.

As well as ready-made hereditary schemes, other scheme-tapes would also presumably be produced in the same way, but as “blanks” which could not be used as programs until they had been modified.

**A3.3 Calling the Labels of Schemoid “Tapes” which are Physically Remote: Technical Considerations**

Ultimately any thoroughgoing theory of neural activity has to come to terms with the problem of how electri- cal signals and chemical storage of memory interact.<sup>19</sup> In the present paper this problem does arise, but it is posed in a somewhat different way: Given that we are considering hypotheticalai chemical changes, these changes are postulated to be intimately concerned with

<sup>19</sup> The evidence for these two phenomena, considered separately, is scarcely to be doubted. For example, see Eccles 6.(1964) or Katz 21.(1966), and Ansell and Bradley 1.(1973), respectively.

“calling the labels” of other remote chemical systems. In other words we are really talking about chemical interaction across a remote<sup>20</sup> distance — “by telephone” so to speak.

If such a system is to work at all, it is difficult to see how it could operate other than by electrical signals  $\square$ <sup>21</sup>. The question then becomes one of explaining how such electrical effects, normally having a chemical effect at close range, could be *transmitted* selectively to relevant sites, and how they could be *used* there to call appropriate chemical systems into play, in the face of considerable amounts of random infra-red “noise” within the body. For  $\triangleleft$  this purpose, a mere “blip” *at* the receiving end would probably not do; but if it could be analysed into a temporal or spatial spectrum beforehand, then this could act very specifically — like a key received into a lock. Such analysis could be achieved if the intervening medium were to act “dispersively” (somewhat like a prism).

63c2

Calculations <sup>31</sup>:(Traill, 1977: “Part B” below) suggest that these requirements could reasonably be met simultaneously by using existing *myelinated* axon segments as wave-guides, with chemical re-activation at the intervening nodes. Thus the role of the myelin may be more than just one of speeding up the conduction of signals, it could also have a more subtle role — assisting in the decoding or sorting of jumbled signals.

If correct, this account might help to explain the comparatively stereotyped behavioural repertoire of invertebrates, and other animals including neonates whose axons are lacking in myelin. In such cases it is plausible that only local signals and simple traditional “spikes” will be usefully received.

In short then, the postulate that one schemoid can call others, in a highly adaptable way, need not necessarily be left as a metaphysical abstraction. On the contrary, it seems feasible that the process may be amenable to detailed explanation — the outlines of which have been briefly suggested.

#### A3.4 Schemes, and Piaget's first two Sensori-Motor Stages

The activity of the first stage is generally decribed simply as an *exercise of reflexes*. Now I would at least like to raise the question of just what is meant by “exercise” in this context. In normal usage, “exercise” implies that something is being developed or corrected — though it is often not clear exactly what the basic changes are which make up this improvement. To say that the infant is “getting to appreciate the reflex schemes” scarcely does more than re-state the problem; so let us try to put more precision into our ideas here.

With this aim in view, we may look ahead to stage 2 to provide clues as to what has been going on clandestinely since birth. What then are we to make of the overt primary circular reactions of stage 2? Here we have “movements grouped in coherent systems superposed on the reflex systems” (Piaget, 1954, p. 211 ff)<sup>24CR</sup>, and “coordination between hand and mouth in thumbsucking” just after one month (*ibid.*, p. 106 ff); so what basic mechanisms might underlie these phenomena? And how do they arise?

<sup>20</sup> distance  $\gg$  (wavelengths for the resonance frequencies involved in the chemical changes concerned). Such chemically significant wavelengths are likely to be of the order of 1 to 100 microns, i.e. in the infra-red range.

<sup>21</sup> $\square$  Moreover, for such frequencies and distances, the signal must evidently use a *radiation field* rather than the simple reversible *induction field* which is normally taken for granted in physiological discussions dealing with electrical signals. For further discussion see Skilling <sup>27</sup>:(1962), Chapter XI, especially pp. 167-168.

<64:> Suppose that there is a particular situation “A” (or “Arm-in-striking-position”<sup>22</sup>) which the infant can *recognize* by some means, and that there is therefore some sort of schemoid element “a” which corresponds to this situation. Suppose also that, *provided* the situation is “Arm-in-position” initially, then a certain overt action “Bang” will in fact normally produce situation “Consummation” which happens to be inherently rewarding to the infant. (And just as *a* is the internal coding for the recognized situation “Arm-in-position”, so is *c* the coding for some positive consummatory effect, and *b* is the coding for the intervening action “Bang.”)

Thus if the thought domain were populated by a sufficient number of “tapes” in the form “a-b-(c),” then whenever A happened to occur, it would “call” the label *a*, so that the program *b* would be put into effect. “(c)” would plausibly have a different status: as well as any subjective-effector role it might fulfil (presumably acting ultimately on the hypothalamus) it would also act as a positive-affect *tag*, serving to slow down the decay of the scheme-tapes “a-b-(c).” After consummation sensation *c*, the situation may be thought of as happening to relapse to Arm-in-position (due to gravity perhaps), so that if enough a-b-(c) tapes are still present, the cycle is likely to keep repeating — justifying the term “primary circular.” Insofar as *Bang* was originally some sort of hereditary *reflex* response in its own right, then Piaget’s description of “superposed on the reflex systems” would appear to be appropriate if this means *a* being superposed on *b* or onto a larger tape containing it. This description would also seem appropriate even if *b* had been modified from its hereditary form in the interim, by other earlier accommodations “superposed” on the original hereditary *b*, producing an artefactual *b*’. But what about Piaget’s “coordination between hand and mouth...,” or Bruner & Bruner’s (1968)<sub>5</sub>: “Eye, Hand and Mind”? We now have *parallel* activities, and moreover they are *coordinated*. Can such phenomena be explained in terms of linear structures? Well some clues are offered in Monod and Jacob’s <sup>23</sup>(1961) conference summary; notably their *Model IV* in which two separate *linear* chromosome-controlled processes are mutually interdependent, due to the products of the first causing *inactivation* of the *repressor* for the <> second (thus facilitating it) — and similarly the products of the second facilitating the first.

Thus, in our terminology, we may have two types of tape operation in conjunction:

$a(\text{call label}) \rightarrow f_1(\text{facilitate other}) \rightarrow p_1(\text{proceed if facilitated}) \rightarrow h(\text{hand program}) \rightarrow (c)(\text{consummation}).$

$a(\text{same call}) \rightarrow f_2(\text{facilitate other}) \rightarrow p_2(\text{proceed if facilitated}) \rightarrow m(\text{mouth program}) \rightarrow (c)(\text{same consummation}).$

A number of variations on this theme are possible: notably involving more cross-feed facilitations, degrees of dependence on such support, and larger numbers of parallel tapes; but this example will suffice for our present discussion.

So then, if the infant does have mental structures like these by stage 2, how did they come to be there? Firstly, we should recognize that some of them may have been there all along. If they did not manifest themselves earlier, this may have been for maturational reasons, explicable in terms of our ( $a-f_1-p_1-h-(c)$  and  $a-f_2-p_2-m-(c)$ ) model: There may not have been numerically enough of the relevant tapes available for them to adequately facilitate each other, or to reach some effector-threshold. Or perhaps the facilitation pathways were not yet available — maybe because of delay in myelination.

<sup>22</sup> As a means toward making the following algebraic approach somewhat easier to follow, we may use appropriate whole words or phrases as interchangeable algebraic symbols for their own initial letters. Thus Arm-in-position ° A; Bang-(spoon) ° B; ... etc.

But assuming we are agreed that some particular behaviour pattern *has been learned* by stage 2, then how do we account for it? Take the “*a-b-(c)*” case first. It was suggested <sup>29:M12</sup>(Traill 1975 and 1976 (A1 above))<sup>28:A1</sup> that the process starts with populations of two different hereditary scheme-tapes: (*a<sub>label</sub>-a<sub>program</sub>*) and (*b<sub>label</sub>-b<sub>program</sub>-(c)*) and that approximate simultaneity of use brings some of them into physical proximity — allowing for some “crossovers” to occur, so that we then obtain some tapes with the configuration: (*a<sub>label</sub>-b<sub>program</sub>-(c)*), as required. Presumably we would also get some (*b<sub>label</sub>-a<sub>program</sub>*); though without the “(c)” to protect it or induce its reproduction, this type of tape might not survive for very long.

Some practical variations on this can be achieved without changing the above “algebraic” statements. Thus, for instance, “*b<sub>label</sub>*” might simply be absent, or be represented by a dummy mode, according to whatever provisions heredity might have made. Alternatively, perhaps the tape elements are joined in other less neat ways, possibly with some repressor action to quash the superseded elements. This seems rather haphazard and inefficient for a potentially recursive biological system, but perhaps we should be careful about dismissing it in view of its possible similarity to the original genetic systems. <65:>

Another more attractive idea is that isolated labels are tailor-made by incoming signals, and that they can then augment *or* replace existing labels on what was a hereditary scheme. They would thus be comparable to *episomes*<sup>23</sup> becoming attached to chromosomes. Anyhow these various suggestions could all be described as “tape transplants” of one sort or another; and perhaps we should simply leave it at that for the time being.

But what about the more complex systems like our (*a-f<sub>1</sub>-p<sub>1</sub>-h-(c)*) and (*a-f<sub>2</sub>-p<sub>2</sub>-m-(c)*)? There would seem to be two possible sources for such non-hereditary new schemes: They *could* somehow be built up from scratch. But more plausibly, and more in accord with Piaget, they could result from “mutations” of other tapes. This would be essentially the same then as for the above simpler case; but possibly starting from more complex hereditary tapes. These pre-set tapes might in some cases, be retained genetically as *blank* schemes, specifically “with this purpose in mind” — a sort of construction-kit with some scope for coding according to local conditions. If this is the case, then *imprinting* would seem to supply a particularly striking illustration of such last-minute detail-filling.

When learning is less predetermined, we are left with the problem of how sensible-and-adaptive schemes can emerge from apparently arbitrary processes. But this looks very like the problem of evolution in miniature (and that should not surprise us if we think of mental activity as substitute-evolution: survival of the fittest amongst expendable models rather than amongst the macro beings of the “more real” world — analogously to the industrial use of expendable scale models and the like). A mutant tape might fail to survive because it produces no satisfaction, and therefore fails to be labelled with a supportive tag, according to our present postulate. Or the mutant tape and its potential collaborator-tapes may fail to provide the mutually necessary facilitation for their joint operation so that they fail for “technical” reasons.

Under such a general non-specific procedure, there is likely to be considerable wastage of potentially useful codings; but if these are on a molecular-population scale then this will be no great hardship — especially if their material is re-usable with minimal change. Also the process is likely to go on for some time before there is anything much to show for it. This then is presumably what is happening during the infant’s first month (stage 1), before the overt consequences appear at stage 2.

<sup>23</sup> which include such things as non-virulent viruses <sup>19</sup>(Jacob & Wollman, 1971).



Other species have different ecological requirements  $\diamond$  and limitations so we may expect different mixtures of: predetermined *fixed* schemoids; largely predetermined but *imprintable* schemes; and open-ended *flexible* schemes. Thus a spider's repertoire of behaviour is highly stereotyped, and the human's repertoire is very much left empty "in anticipation" of appropriate filling-in from experience, while a new-born lamb shows conspicuous elements of all three types of schemoid: a well developed hereditary locomotive ability<sup>24</sup> on the one hand, plus a reasonably flexible intelligence potential, and also a tendency to imprint to its supposed mother.

### A3.5 Taking Liberties with the Rigidity of Mathematical Groups

The mathematical group is much discussed in connection with Piagetian theories, though usually for the periods *following* sensori-motor. It implies the following properties, not all of them generally acknowledged — cf. Leech and Newman 22.(1969) for example. In the discussion we will use " $\diamond$ " to represent a generalized operator, including such operators as "+, −, ×, ÷" and many others which are not arithmetical.

Mathematicians accept that  $\mathbf{A}-\mathbf{B} \neq \mathbf{B}-\mathbf{A}$ , but in practical group theory it is often not made explicit that  $\mathbf{A}$  and  $\mathbf{B}$  are expected to both belong to the same set; for instance both taken from the *unbounded* set of *real* numbers, in which case  $\mathbf{A}\cdot\sqrt{\mathbf{B}}$  would not satisfy the requirements.

Here however, this sort of possibility is considered explicitly in "property (0)."

(−1) A "substrate" consisting of a recognizable *set of states*; and also a *set of fixed operators* which may be considered alternatively as a smaller set of  $n$  variable-operators whose properties may be *fixed* by a given parameter taken from a *set of parameters*.

(0) It is assumed for mathematical purposes that the parameter set is co-extensive with the set of states; thus we have (equivalently),  $n$  *binary*-operators applied as follows:  $\mathbf{A} \diamond \mathbf{P} = \dots$  [or writing it more rigorously:  $\mathbf{A} \diamond (\mathbf{P}) = \dots$ ], where  $\mathbf{A}$  and  $\mathbf{P}$  are both members of the state set (though  $\mathbf{P}$  also acts as a parameter) and " $\diamond(\cdot)$ " is one of the  $n$  variable-operators; [or to be more explicit: the  $n$  variable-operators are  $\diamond_k(\cdot)$ , where  $k = 1, 2, \dots, n$ .]

(1) "*Closure*" which means that for " $\mathbf{A} \diamond (\mathbf{P}) = \mathbf{C}$ ,"  $\mathbf{C}$  is always a member of the state-set as well as  $\mathbf{A}$  and  $\mathbf{P}$ . That is, the recognized operators cannot cause a break away from the recognized set of states; and this <66:> means that the whole universe of discourse has been encapsulated within the system, thus giving complete predictability (mathematically).

(2) An *Identity* element " $\mathbf{I}$ " (producing no change) is associated with each variable-operator, thus:  $\mathbf{A} \diamond_k (\mathbf{A}_k) = \mathbf{A}$  for all member states  $\mathbf{A}$ , and for each  $k$  up to  $n$ . For example, in ordinary algebra:  $a + (0) = a$  and  $a \times (1) = a$ . [It is also taken to be true that  $\mathbf{I}_k \diamond_k (\mathbf{A}) = \mathbf{A}$ , where we now have  $\mathbf{A}$  acting as the parameter.]

(3) *Inverse*. For any given variable-operator-cum-parameter,  $\diamond(\mathbf{P})$ , there will also be an inverse parameter which will undo whatever change was made originally. Thus if  $\mathbf{A} \diamond (\mathbf{P}) = \mathbf{C}$ , then  $\mathbf{C} \diamond (\mathbf{P}^{-1}) = \mathbf{A}$ ; where  $\mathbf{P}^{-1}$  is the inverse parameter.

(4) *Associativity*. When a variable-operator,  $\diamond$ , is to be applied twice, to three elements:  $\mathbf{A} \diamond \mathbf{B} \diamond \mathbf{C}$ ; then associativity will hold if and only if  $[\mathbf{A} \diamond \mathbf{B}] \diamond \mathbf{C} = \mathbf{A} \diamond [\mathbf{B} \diamond \mathbf{C}]$ . This can only make sense if condition (0) holds true — at least partially, because  $\mathbf{B}$  *has to* act as both a state and a parameter *if* the equation is to be meaningful.

<sup>24</sup> I am indebted to Dr. A. Sloman for raising the issue implicit in this example, and for useful discussion arising from it.

[(5) *Commutativity* is *not* required, even for mathematical groups; but as a negative example it may help to round off the picture. Thus in general  $A \blacklozenge(B) = F$  while  $B \blacklozenge(A) = G$ ; where  $F$  and  $G$  need not represent the same state] A close examination of these properties rather makes one wonder whether the supposed properties of a “mental-concept group” are really the same set as those specified for mathematical groups. The Pure Mathematician ignores the worldly implications of (-1); and he requires (0) whether he says so explicitly or not; while the remaining conditions are insisted on uncompromisingly.

From a practical biological point of view however, such rigid properties can only exist as an ideal; to be aspired to perhaps, and approximated on a “pass percentage” basis (see Gasking’s 8:(1960) “cluster” concept), or even attained by one *part* of the mind’s activity, but never actually achieved rigorously. After all as Ashby 3:Intro(1956) has pointed out, such a closed and stable system is inert or dead as far as the rest of the world is concerned. Nevertheless, as we saw earlier, strivings after closure in our mental models are likely to form an indispensable part of our autonomous mental development. Thus it would seem sensible to consider the question “How can the mental system progress from comparative disorder towards its supposed goal of comparatively group-like structure?”

Initially it would seem that the three *sets of* entities [exemplified by the three letters in  $A \blacklozenge(P) = C$ ] are “regarded” as unconnected. But during developmental  $\blacklozenge$  progression, the three sets gradually *tend* to become co-extensive as required for the mathematical group: properties 0 and 1, above; and arguably this is the most important change to emerge from the developmental process at this stage. Let us therefore talk of “*pre-groups*” in this context, to refer to those systems which have some of the properties of a group and some means whereby sets could be delineated in practice (by recognizing tags or properties of the members, “*intension*,” and/or by confinement within a boundary, “*extension*”).

### A3.6 The Practical Mathematical Achievements of Evolution and Heredity

Clearly the underlying *substrate* for thinking arises through genetic means, and this presumably provides the material basis for the three sets of “states.” The internal state-counterparts themselves may be considered as genetically-determined stereotypes, operating through highly specific pathways such as those in the visual cortex (Hubel & Wiesel 1959, 1962, 1963a, 1965) 11:13:14:17. Moreover, the underlying mechanism might now be reasonably guessed at and “designed” 12:(Hubel & Wiesel, 1961; Julesz, 1975)20.

[The details of such pathways, like embryological developments in general, cannot be divorced from environmental influences. (Hubel & Wiesel, 1963b, 1963c)15:p994, 16:p1003]

Nevertheless it may be argued that the environmental influences here are normally sufficiently predictable for hereditary codings to “take them for granted” — just as we may normally make many cultural assumptions in our social encounters. Thus if the experimenter or clinician finds major lapses from the *developmental* norm, this may perhaps be explained as resulting from excessive (“unnatural”) departures from the *physiological* norm 2:Design.(Ashby 1952, 1956)3:Intro. We may reasonably use the term “*ortho-maturational*” for the non-genetic component of a phenotype which does depend on the environment being in the “normal” range.

And another related side-issue: Hebb (1949)10. and many workers since, have made much of synaptic plasticity as the fundamental mechanism for mental functioning. By contrast, it would now seem that such changes might be in the nature of comparatively crude physiological readjustments of overall weightings; and, important though this may be, it would not be directly responsible for the main transactions of ongoing thinking, perception, and action. Even its

supposed role in Long Term Memory may be open to question, if only on the grounds of stability and economy.] <67:>

Anyway, a certain amount of perceptual pre-processing is provided as a hereditary legacy. Whether this pre-processing ends at the striate cortex with the degree of organization appropriate to that region, or at the inferotemporal lobe with *its* degree of organization, 18.(Iversen, 1974; Pribram, 1972)<sup>26</sup>; or at any other centre, it still makes no difference in principle for our immediate purpose. All we need ask is that it should end *somewhere* in an array of inherited disparate state-indicators. (Of course this is meant to apply to the input channels for *all* sense modalities, not just the “more popular” visual system.) One important task then for any mentally adaptable animal is to set up *pragmatically meaningful* linkages between these perceptual elements: both within and across sense modalities. Meanwhile, insofar as such linkages are absent, there will be a corresponding degree of compartmentalization with respect to sensory input; indeed *qualitatively* there may be more than a superficial resemblance between this sort of conceptual separation, and such phenomena as (i) those experienced by split-brain subjects, or (ii) the compartmentalization of beliefs according to the role being played.

Similarly we may think of genetic or maturational “sealed units” of effector post-processing, by which the thought domain can put its “conclusions” into effect: either as *motor* action, or by internal *modifier* action — controlling attention, assimilation, and such like. Again it is not vitally important just where such effector channels start to be ready-made, and where they are still a direct manifestation of variable scheme action; — we may assume that there will be some of each, so both must be explicable within the terms of the model. Indeed, we might even have to contend with a *gradual* or *joint operation* transition from one to the other.

Finally, as we have already seen, some of the variable schemes themselves are likely to be of genetic or ortho-maturational origin.

Now in terms of the mathematical terminology of the previous section: if we can decide on where to draw the lines between (i) sensory input, (ii) internal variable scheme-thought, and (iii) effector output, then we can notionally draw up a matrix similar to Table 1, for any *integrated* thought-centre. Emphasis is put on “integrated” because it seems appropriate to consider each informationally-isolated unit as a *separate* thought unit until such time as it achieves some sort of meaningful dialogue with other units, and thereby loses its autonomy. Thus it can be seen that Table I itself fails to qualify as it stands, because each successive triplet of (row)-(column)-(diagonal element) forms an isolated unit on its own — so we <> actually have *four* separate integrated units, rather than *one* as implied.

Moreover, at birth we may assume that for an exhaustive table of sense-patterns and effector-patterns, many will lack even this degree of integration. In general we may think of them as “Conditional Stimuli” and “Conditional Responses” which are still “neutral,” so they correspond to just an identifiable column, or just an identifiable row, but lacking any entry in the body of the table. [Things *might* be different at the micro level; for example if each relevantly labelled tape has an *arbitrary* program, so that it is integrated on its own, but not if it is considered as a statistical representative of a population. However not even this complication would arise if the program part of each tape were “blank” or simply absent. Of course for such micro-distinctions, any exhaustive table would be of astronomical dimensions! ]

Anyhow, the ortho-maturational and hereditary achievement may be said to be the “drawing up” of such an exhaustive table, but *leaving most of the entries empty* — though allowing some “diagonals.” Indeed insofar as row and columns represent *patterns* of input and output, it is an open question whether these rows and columns are even all endowed with identifying codings at this stage: these could be added arbitrarily later. As for size: if we assume that the basic *constituents* of these input and output patterns are limited by anatomical constraints, and the

67c2

number of fixed hereditary “sealed unit” combinations of them is also limited, then it is possible that an exhaustive table would be no more than huge, rather than “immense” in Elsasser’s sense (1961)<sup>7</sup>; of  $10^{\text{a huge number}}$ , as we might otherwise expect.

### A3.7 The Practical Mathematical Achievements of Stage 1 (Manifested at Stage 2)

The achievements of stage 1 may then be described as a filling-in of some more diagonal elements in the table — or perhaps discovering that the particular entry prescribed by heredity-or-maturation does *not* work and should be replaced by a different entry. It is, of course, simply a matter of convenience which entries fall in the diagonal position. The point is that at this stage there should tend to be a *single* preferred response pattern to a given stimulus pattern; and whatever this turns out to be, if we can arrange for the relevant entry to be kept on the diagonal, then our stimulus patterns and response patterns will turn <68:> out to be listed in corresponding order. We should also bear in mind that any real imposed stimulus-pattern is likely to be assimilated as a *series* of *recognizable* sub-patterns which *include internally generated components*, so from moment to moment the part of the table “in use” is likely to change dramatically; this partly explains how the *number* of rows and columns might be kept to a manageable size — many of the response patterns concluding by “passing the buck,” or simply running in parallel.

68c1

Another description of these attainments is to say that the infant has mastered a considerable number of (disconnected and probably temporary) one-dimensional abstract spaces at “groupment” level, (not “group” because there is no appreciation of a reversal operation as such — even though a sort of “zero-resetting” may, in fact, occur by default). In other words, given a recognizable initial situation, the infant may habitually come to produce the right effector action pattern to bring about a consummation; but without involving any invidious choices between comparable paths, if only because other potential choices will have been forgotten.

### A3.8 Achievements During Stage 2

Assuming that one-dimensional link-ups do occur in stage 1 as described, then to what extent are these made permanent? — and when, and how? We may suppose that initially such schemes are quite ephemeral — though their statistical decay-rate may depend on the extent to which their population is tagged as rewarding and therefore worth preserving for the time being — until something more pressing drives them out of the infant’s attention. Where such schemoid formulations do become more permanent we may reasonably identify the resulting stable populations as schemata, *even if they may have a rather more primitive connotation than is usual in Piagetian discussions*. As for when such schemata develop: they may well be theoretically capable of formation right from birth or earlier, but probably do not play a *leading* role until stage 2.

Just how this stability is reflected structurally remains to be explained. Let us take up the earlier suggestion that such permanence derives from corroboration of some sort; and in this case it is likely to take the form of mutually supportive cross-feed, as in Monod and Jacob’s *Model IV*, discussed above. But suppose this is true, we have already been attributing this sort of mutual support to normal ephemeral schemes — at least in some degree; so where might the difference be? <>

68c2

Well it could be essentially *just* a matter of degree — perhaps involving some sort of “critical-mass effect,” in which any exceeding of a critical population density gives a local locked-on system. Another possibility is that the hypothesized electrical intermediaries in the cross-feed paths come to be circumvented, thus giving a much more immediate “alliance” capable of withstanding disruptive influences. These two possibilities would seem to be mutually compatible; and indeed it would seem necessary to postulate something like the prior *local*

growth of direct mutual support in order to explain how the supposed electrical links could be *superseded*.

Anyhow, whatever the mechanism, any new promotion of a significant body of ephemeral schemes into long-term schemata is likely to have profound effects on mental functioning, and it rather looks as though stage 2 produces just such a major milestone comparable to the boundary which occurs later between the “Pre-operational” and “Concrete Operations” sub-periods. Moreover, the reason is probably similar: Adequate numbers of schemes for manipulating elements basic to the particular period<sup>25</sup> have just acquired reasonable permanence and salience, thus opening the way for more time-consuming explorations of group-like structures. This means that reverse operations, consideration of alternatives, and more advanced waiting-for-response-before-proceeding become postible within the respective contexts.

### A3.9 Stages 3 and 4 (Approximately)

Let us consider Table I again. By now the infant has managed to manufacture a substantial number of apparently unique “diagonal” elements, and the infant has also managed to give these diagonal action-codings sufficient permanence so that they might *now* be worthy of attention in their own right — as if they were perceptual “sealed units.” This then opens the way for higher order schemes which refer to *other schemoids* by “name,” without necessarily calling them into effect. Amongst other things, we may suppose that such inward-looking higher schemes would be able to “list together” those lower order schemoids which were capable of performing a particular consummatory task; (perhaps by first arbitrarily calling such lower schemoids, and then “forgetting” them if they fail to produce the arbitrarily pre-set expectation).<69:>

This would be an important step forward. It would give a means for forming practical *sets* of one-dimensional linkages; and these presumably offer *alternative* routes,  $b_1$  and  $b_2$ , to the elementary consummation ( $c$ ) — given a specific starting situation,  $a$ . We therefore now have a basis for producing a mental model of an *enclosure* around a *two-dimensional* space<sup>26</sup>. (Piaget & Inhelder, 1948)<sup>25:ChC/Sp</sup>. This in itself is only a beginning: as it stands, such a link-up does not constitute a model of an object — nor even a two-dimensional equivalent of an object — because it is restricted in both its starting-point and in the direction in which the boundary may be traced.

However, other types of higher order scheme should also be attainable. Suppose for instance that there are now two recognized starting points ( $a_1$  and  $a_2$ ) from which  $c$  may be reached deliberately; and that the infant comes to discover, by chance, that  $a_2$  lies on one of the alternative routes which start from  $a_1$  — and vice versa. This then gives a means whereby the reversal pair  $a_1a_2$  and  $a_2a_1$  can be classified as a special sort of set, whose usefulness in group construction then becomes open to discovery. In order to explain the attainment of a set which included a reversal *away from* the consummation state  $c$ , it would seem necessary to change the infant’s “drive mode” so that, for the time being,  $c$  no longer provides a satisfying goal, but that  $a_2$  (say) becomes the state to be sought after; — it being assumed that the  $c$  and  $a_2$  would not lose their coded identities during this switch-over. Furthermore it is likely to be just a matter of exercisc for the infant to be able to cope with *any* recognizable starting-point around the loop (Traill, 1975)

<sup>30:Sensori/LaTr</sup>.

So now our infant has met most of the requirements necessary for the formation of a mathematical group — at least for two dimensions: (–1) *Substrate of states and operators*, yes, (0) *Parameter set = state set*, generally dubious; (1) *Closure*, partially yes (on boundaries of two-

<sup>25</sup> Viz. *input* “sealed units” for Sensori-motor; or *object schemata* for the Operational Period.

<sup>26</sup> “Space” may be understood here as sometimes meaning geometrical space, but also sometimes meaning other sorts of topological space.

dimensional object-perception loops); (2) *Identity*, yes (if only by inaction); (3) *Inverse*, partial yes — as for closure; and (4) *Associativity* remains dubious along with “0” on which it depends. This is not perfection, but arguably the most important properties are there to an adequate extent, thus giving sufficient capability for the infant to stumble onto reasonably correct models of real objects if he “accepts” fulfilment of group-like properties as a “worthwhile goal.”

A related consequence of the higher order schemes is the connecting up, into sets, of those schemoids  $\diamond$  for different perceptual modes which happen to display a functional correspondence.

It remains then to probe a little more deeply into how, in *mechanistic* terms, such sets of boundary-tracing schemata (linked by a higher schemoid) come to acquire the extra stability just implied in the “goal” concept. Two general possibilities come to mind: (i) that these “higher order” schemes acquire stability in essentially the same way as for lower order schemoids—indeed it would be conveniently economical to suppose that the two types are identical except for the sorts of entities which happen to be code-referenced in their respective “lists.” (ii) It was suggested 29:M12 (Traill 1975 and 1976 (A1 above))<sup>28:A1</sup> that such structures might be “tested” more-or-less regularly or continuously for *closure*. Presumably some sort of exercise, perhaps during one of the sleep modes, and perhaps associated with one or more of the EEG frequencies, would attempt to pass control from one element of a set to the next. If the set did have mutual closure, then this “control” would be kept “within the family,” but not otherwise; and stability could then derive from this ability to hold control — possibly by replication during such exercises.

These two suggestions appear to be compatible however, and indeed the second could be used to help explain the growth in local tape-population density which could then promote the first.

### A3.10 Stages 5 and 6 (Approximately)

It should be borne in mind that Piaget’s “stages” are *observational* categories. As such, they need not necessarily be a safe guide to underlying unobserved developments. In the early stages, when presumably not too many things are going on simultaneously, the correspondence between observed, and non-observed events is likely to be reasonably satisfactory; but at later stages we would be wise to exercise greater caution in the interpretation of the observations. Thus stages 5 and 6 (the second year) are justifiably considered as the closing stages of sensori-motor development, but might they not also be the clandestine starting-phase for the following *operational period*? After all, it was supposed above that the initial sensorimotor development was also clandestine.

In particular it seems likely that the experiments with sequential displacements of objects should logically be associated with the following *operational* period, because they take some form of *object* and its internal schema as basic elements.<sup>27</sup> Also the same <70:> sort of argument applies to observations concerning obstacle removal. In fact, it rather seems that these are a recapitulation of the stage 1 activities, but at a higher level — trying to form coherent patterns of *operation* whereby objects can be moved around, rather than trying to form coherent appreciations of objects themselves.

Admittedly the “objects” as perceived in stages 5 and 6 are probably two-dimensional so that some incomprehensible anomalies are likely to confront the child in due course, but they nevertheless provide a very attractive approximation to reality for an individual who has hitherto had to cope with very much less. Small wonder then if he “goes off half-cocked” into the

<sup>27</sup> instead of a constituent object-*property* and its internal “sealed unit” signal.

mysteries of the operational period. [Nor are adults immune from such incaution, despite the proverbial warning that “a little knowledge is a dangerous thing.” Indeed for phenomena less well defined than permanent objects, we may not be *able* to do better than use our inadequate knowledge, however dangerous this may be. Such is politics for instance. Moreover, by no means all material things can be dealt with neatly as “rigid, permanent objects,” as Green and Laxon<sup>9</sup>(1970) admirably illustrate in the title of their article.]

But to return to the closing stages of the sensorimotor period as such: Despite any “pre-mature” excursions into the next period, the child will meanwhile also be building up alternative two-dimensional schemata which will turn out to have some interesting common features; and ultimately these are likely to be resolved in the formation of schemata which capture the properties of three-dimensional groups. The process is likely to be broadly analogous to that for producing two-dimensional schemata, though with some additional complications:

“Neat” geometrical groups are more difficult to design in three dimensions than in two; thus, for instance, 60° rotations about one axis (perpendicular to the plane) generate a perfectly satisfactory group (“C<sub>6</sub>”). But if we try mixing 60° rotations about two perpendicular axes simultaneously then the result is, at best, haphazard (until we invoke formal trigonometry). However, a judicious restriction to using mainly 90° rotations can circumvent such embarrassments, and at the same time provide the proper “feel” for the three-dimensional nature of an object.

So better late than never, by the end of his second year the child will probably have sufficient grasp of the true three-dimensional nature of objects for him to be able to make good some of the perplexities he may have fallen into in the meanwhile. ◊

### A3.11 Subsequent Recapitulation (Recursion)

70c2

It has already been suggested in the above discussion that the *operational period* will follow substantially the same course, but at a different level, using objects and object schemata rather than their precursors. It has also been hinted that the following *formal operations period* might follow the same pattern as well, using something like the entities of set theory or logic, in place of objects. One might even logically postulate a fourth period to include meta-mathematics; and the very fact that we talk about algebras (plural) rather suggests this.

Anyhow, the pattern which at least the first two periods were supposed to follow consisted of two phases in each case: An initial phase in which some basic facts about how one elementary state or element (appropriate to the respective period) can be operated on so as to produce another particular state or element. This is then followed by a second phase in which such information is classified and systematized into generalized rules or groups, allowing for maximal efficiency in problem solving (within the limited understanding of that period), and by the same token providing schemata to be used as constant elements for the following period, if any.

### A3.12 Summary and Conclusion

There is a *prima facie* case for believing that mental functioning can be explained mechanistically, in terms of large populations of linear biochemical codes which are capable, in some circumstances, of communicating at a distance. On this basis, an attempt is made to solve some of the problems in “designing” such a system by offering an analytical account of various phenomena characteristic of sensori-motor development.

**ACKNOWLEDGEMENTS**

The author gratefully acknowledges his Indebtedness to Dr. N. E. Wetherick and Ms Sherrill Hallmond for critically reading the draft of this paper; and to Prof. F. H. George for his encouragement and support.



## Part B

88-  
135

### TOWARD A THEORETICAL EXPLANATION OF ELECTRO-CHEMICAL INTERACTION IN MEMORY USE: THE POSTULATED ROLE OF INFRA-RED COMPONENTS AND MOLECULAR EVOLUTION

Monograph 24: Brunel University, Institute of Cybernetics, UK.  
(Previously published as 'hard copy' in 1977, 1978, and 1980)

*Available in full as a separate document:*

24H[www.wbabin.net/physics/traill8.pdf](http://www.wbabin.net/physics/traill8.pdf) or 25H[www.ondwelle.com/MolecMemIR.pdf](http://www.ondwelle.com/MolecMemIR.pdf) or

#### SUMMARY OF CHAPTERS

##### **B1. Introduction: the search for a rigorous structural theory of memory**

This chapter poses some basic questions about how the **phenomena** of behavioural psychology could possibly be rigorously explained in terms of realistic biological mechanisms — in particular questions about selective communication with different chemical memory-stores.

As long as we insist that physiological action-potential is the basic indivisible unit of such communication, then any rigorous explanation proves to be disturbingly elusive. However there turn out to be some persuasively corroborative arguments that there may be an important and rich fine-structure to these and other neural phenomena — involving frequencies above  $10^{11}$  Hz — and this would make the explanatory task much more feasible.

##### **B2. How could bio-electrical messages be converted into meaningful and specific chemical coding — and be retrieved ?**

It can now scarcely be doubted that mental activity involves both electrical communication and chemical storage. The prime question then is, what connection could there be between these two types of phenomenon? This leads to an evaluation of the role that infra-red and sub-picosecond events might play in providing such a link.

However we also need to be able to offer biologically feasible mechanisms for both the initial encoding of memories and their subsequent selective retrieval. Thus suggestions are offered to explain selective triggering of particular chemical stores, and the consequences which are likely to follow — as motor action or further internal triggering. But the most enigmatic feature of all is the laying down of memory in the first place; and here it seems necessary to postulate a system of trial-and-error at molecular level, so that the encodings of both action and perception can be judged by their results — in line with Piagetian concepts of mental development at the behavioural level.

##### **B3. Transmission properties for various frequencies of electromagnetic signal within nervous tissue, and the special case of saltatory conduction**

This chapter provides a corroborative cross-check by making an independent analysis of the (saltatory) transmission-characteristics for myelinated axons presented with all frequencies from 1 KHz to beyond  $10^{14}$  Hz. Factors considered include: breakdown of circuit-theory assumptions for the very high frequencies, free transmission within the myelin dielectric, reflection at the co-axial boundaries, limited protection against water's absorption bands, evidence for signal-blockage, and possible artefact results. The conclusion is that audio-frequencies and infra-red frequencies are both suitable for such transmission, but not the frequencies in between.

##### **B4. The second-lowest mode of transmission in co-axial myelin ( $H_{1,0}$ ): optical dispersion of infra-red**

This chapter argues that existing myelinated segments could also act as dispersive media, similar to those postulated in chapter B2, by using "higher vibrational modes" within the myelin.

##### **B5. Evolution of communication methods: suggested extensions to Bishop's two stages**

This chapter speculates on the evolutionary development of communication systems in animals, and suggests that the basic elements of infra-red transmission may be very ancient and primitive.

##### **B6. Other related architecture in brief: glia, paranodal regions, and cell-body interior**

It seems likely that infra-red components of a signal will be "steered" into their *own* reception sites, which need not have any close connection with synaptic sites. Instead *para-nodal regions* and glia are likely to be involved. Transmission of infra-red is likely to be limited to distances of about cell-size except when they can find a lipid optical path.

## Part C

136

### *DEVELOPMENT AND APPLICATION<sup>1</sup>*

Developing the hypothetical concepts more deeply —  
and applying them to explain a number of poorly  
understood psychological phenomena, including  
dysfunctions of the system which result in  
clinical neurosis or psychosis

“A molecular theory of brain organization, with explanations of  
neurosis, psychosis, and normal functioning”.

## Chapter C1

137

***A Broader Strategy for Research — seeking coherence amongst well-defined elements***

## SUMMARY OF CHAPTER

This chapter serves two purposes, though this may not be immediately apparent. The manifest topic is its critical dissection of Scientific Method, seen as a *social* thought process; but the same discussion will later be seen as also being significantly relevant as an analogy in an examination of the thought-processes of the *individual*: because both entail Epistemology.

The case is put that, although modern science may be prepared for progress and change in the laws and theories which it directly studies, it is less prepared to question its own *rules of procedure* which take the form of “Scientific Method”. And yet (it is argued), these rules should themselves be open to scientific scrutiny under the rubric of Epistemology. Seen in this light, it may be argued that present methodology places too much emphasis on “direct” experimental testability and too little on the development of “theory” in the form of internal structural logic; indeed I suggest that it is not strictly legitimate to separate these two processes.

Accordingly, we might expect to accelerate scientific progress if we can properly redress this apparent imbalance. But to do so efficiently we will need non-vague statements concerning whatever we take to be the basic structure of the system concerned.

**C1.1 Observability and experimental testability**

After a very extensive review of the work on schizophrenic thought, Chapman and Chapman (1973) suggest, amongst other things, that a tightening-up of experimental method might produce some new, more valid, bimodalities — and hence an improved insight into the relevant variables; (page 337). Such statistically based experimental work clearly offers an important second dimension to augment the earlier clinically-based conclusions, but it is open to question whether statistical experimentation is really adequate for the task — unless it is assisted by yet other approaches.

Even if we look no further than Chapman and Chapman’s proposals, it is clear that a great deal of painstaking work would be needed, <137> and that the value of the resulting payoff would be uncertain and incomplete. Moreover Elsasser (1958, 1961) makes the same point in a rather more systematic way by extending the physicist’s concept of *indeterminacy* into the biological field. Thus whereas a physicist must ultimately choose between precision in the *position* of a particle — and precision in measuring its *momentum*; a biologist must similarly choose how much he is prepared to interfere with (or destroy) the *individual* subject, in the interests of “knowing about” something which no longer exists in that form — or alternatively he must choose between the precision of his experimental categories, and the possibility of finding exemplars to fit such exacting requirements.

138

The latter (statistical) formulation of the experimental constraints implies that we must expect diminishing returns from our efforts to find new insights from statistical surveys — however well designed. This does not preclude progress, but it suggests that sooner or later we will simply run out of resources in one way or another. Of course much can be expected from the intensive investigation of individual subjects, but clearly we will then have to cope with the “interference/destruction” formulation of the indeterminacy principle, as well as any problems we may have in generalizing our results.

Assuming that such arguments are valid, then should we despair of ever reaching an “adequate” understanding of the details of mental functioning, and other complex processes?

Of course it is true that for some time to come, the psychological sciences will be able to draw on the aid of non-psychological techniques in the form of physiological and pharmacological probes; (a semi-salvation for which there is no equivalent in particle physics). But in the end, will we still come back to the problem of an insurmountable <138> knowledge-impasse arising from indeterminacy considerations? Well, it would seem that if we accept normal criteria for “objective measurements”, then we will indeed reach such an impasse at which our “objective” procedures can take us no further.

139

[It has, in fact, already been implied (in Chapter A1, above) that we have been too generous in our criteria of “objectivity” — that we exceed the bounds of objectivity much earlier than we suppose, and that there may indeed be no such thing as objectivity (leading to “episteme”) at all! It is not intended, however, to labour this point here; though it may perhaps lend urgency to our present considerations. The main point is simply that *sooner or later* experimental observations will fail to provide all the answers.]

Pure Behaviourists and many Physicists would have us believe that we should go no further; that any dabbling in what is not objectively testable is at best futile, and at worst obscurantist or occult — and in all fairness one must admit that such dangers do exist. In contrast however, two points might usefully be made without having to delve too deeply into the philosophical issues involved. Firstly, provided we place any reliance on our deductive processes at all, there is a case for *indirect* testing of postulates — even to the extent of testing by means of *remote* logical implications which may not yet be apparent to us, and which are not likely to become apparent if we do not first “take the plunge” and “exercise” the postulates in an *apparently* untestable state. Secondly, even if such postulates were absolutely untestable, they might nevertheless have a perfectly legitimate role to play as heuristic devices — methods of condensing an unmanageable mass of facts into a more parsimonious and *manageable* “mental model” (which is arguably the defining criterion for “understanding”). The classical example of such progress is Newton’s formulation (via Kepler) of <139> Tycho Brahe’s mass of astronomical observations. But we should not scoff at the very real (if inaccurate) heuristic achievements of the Ptolomaic system as an aid to the practitioner in the absence of anything better; its main defect, given the circumstances, was that it was *treated* as absolutely factual.

140

Eysenck’s attack on psychoanalysis, (for instance in his chapter “Little Hans or Little Albert”, 1965), is of some interest in this context. The very term “Psycho-*analysis*” implies an attempted explanation by means of a ‘model’, the basic elements of which are unobservable (and therefore, in some sense, untestable). Whether or not one agrees with Eysenck that the practice of psychoanalysis is a waste of time and money, there does seem to be a good case for conceding that hypothetical analytical constructs such as ‘super-ego’ may well be immune from all experimental proof and disproof — by any normally accepted laboratory criterion. So what value, if any, is there in such intangible concepts? And have they any epistemological justification at all?

Well, insofar as such concepts form part of a *self-consistent, quantitative, and* (perhaps) *dynamic* model, then to that extent we may argue in terms of justification by ‘internal closure’. In this case, such criteria are only vaguely met — but it would be an overstatement to claim that they are not met at all. It is easy to recite the slogan that “they explain everything, and predict nothing”; but neither part of the statement is rigorously true, so it would be unwise to entirely dismiss such semi-logic. (Roughly speaking, we may think of such semi-logic as giving tolerably usable “conclusions” as long as we do not try to use extended chains of inference. Related concepts include subjective thought, intuition, and primary-process thinking; though these terms are usually applied to the individual, and our immediate concern is with *collective* thought <140> within the scientific community, (see Chapter A2, above). Anyhow the point is that although there is some substance to Eysenck’s criticism, nevertheless there may be some *formal* justification for entertaining vague constructs like ‘ego’ and ‘super-ego’. However the case would be

141

much more convincing if a more precise theory (more rigorously testable, by internal closure at least) could be formulated. The question then is, can such a plausible model be devised if we ignore the traditional constraint of the need for *experimental* testability — for the time being at least ?

One apparently valid strategy for improving the internal consistency of a theoretical system is to look for new distinctions and variables, or roughly the same type and scale of magnitude as the old ones, but with boundaries or definitions revised to accommodate the data more closely. Thus phlogiston, having been shown to be a “negative substance”, was more conveniently replaced by the concept of ‘the absence of oxygen’. Similarly a geo-centric planetary theory can be conveniently re-formulated as a heliocentric theory — or a relativistic theory. In other cases we may replace a linear scale by a logarithmic scale (Ellis, 1966), or rotate the axes. This then is the type of theoretical development which one might hope would follow on from any significant advances in Chapman and Chapman’s proposed experimental programme, as referred to in the start of this Section. However it is far from clear that this would be likely to produce any important departure beyond our present vague concepts of mentation. Tempting though it is to hope for a Copernican or ‘oxygen-versus-phlogiston’ revolution, such hope is ill-founded for the complex type of “inhomogeneous” system found in biology (Elsasser, 1958); whereas in physics, “the study of homogeneous [or identifiably discrete] systems”, such hope is demonstrably often justified — and the situation is also similar for elementary chemistry. <141>

### C1.2 Induction, deduction, and internal testability

But there is at least one other strategy which is also available to us. Even in Physics, where such macro-formulations as Boyle’s law did make significant inroads into the subject, it was still found eminently worthwhile to re-interpret these and other phenomena in terms of (unobservable) micro-particles — hence the molecular kinetic theory. So *if* we managed to dream up a *plausible* micro-structure for *mental* phenomena, then it is not unreasonable to suppose that a significant advance in understanding might accompany this development. (To be “plausible” in this sense, a model would not need to be experimentally testable in the usual direct experimental sense — at any rate not initially, and perhaps not at all; but it *would* need to be able to be compatible with reliable evidence from all relevant disciplines — so that it fits in with the ‘internal closure’ of theory in general. This is by no means a ‘soft option’, even if it is somewhat softer than the task of “observing the unobservable”; and indeed the more precisely such a micro-model can be formulated without violating internal closure on an interdisciplinary basis, the more likely it will be that we have stumbled onto *the* correct solution (*episteme*), though we can never know for sure whether we have actually done so (Popper, 1963/1969; see Part A, above). Just as the false testimony of a murderer (if explicit enough) is unlikely to stand up against logical analysis and forensic evidence (if it is thorough enough), so a highly explicit theory is unlikely to survive a thorough logical and interdisciplinary examination if it happens to be false. And this would seem to apply even if we consider only the internal closure or ‘equilibration’ based on previous theories of a similar status, without necessarily relying on ‘objective experimental testing’; — a dispensation which is fortunate if there is, strictly speaking, no such thing as a genuinely objective experimental test, (Chapter A1, above). <142>

It is a matter of some considerable practical importance to clarify what would actually be entailed by our “stumbling onto” a suitable micro-theory. a perfectionist strategy in which nothing but ideal solutions are accepted, and no record is kept of failures or partial successes, would take such a long time to achieve its goal that we should (if possible!) dismiss it as a workable technique. Ashby (1960) illustrates this point (in Section 11/5) with a simple example in which 1000 on/off switches have to be set to a particular combination by *random-based* testing, each test to take one second. Of the three strategies considered: ● the perfectionist all-

or-nothing method would be expected to take more than  $10^{301}$  seconds, (i.e.  $2^{1000}$  seconds, or  $3.5 \times 10^{291}$  centuries!); • a serial-test of switches, holding on to the partial successes (assuming that these are manifest) would take 500 seconds; while • a parallel-but-individual testing of all switches simultaneously would take only one second. Unfortunately the third technique will often be inoperable, so we will frequently have to be content with a technique similar to the second method; but heaven help anyone who tries to solve a complex problem using the first technique alone (or as a sizable component in a mixed strategy)!

For our present problem of developing scientific postulates which are intended to represent reality, the situation is naturally somewhat more involved. For one thing, in Ashby's example both the rules of the game and the nature of the three strategies are presented to the reader ready-made; and even if he has any difficulty in understanding them, he is not likely to see this 'personal' problem as relevant to the example. However in science there is ultimately no infallible guide as to what the rules or options might be, nor is it even indisputably clear just what the objectives are. Even supposing that the switches do operate in a *reliable* on/off <143> manner (and in a genuine scientific enquiry there is no infallible authority to tell us whether they do or not), how are we to know for certain that these (or any) switches are relevant to the problem? They may be mixed in amongst other irrelevant switches — or switches which change the rules applying to the others, and so on. Moreover without "*relevant*" experience to guide us, might we not just as well expect that the recitation of magical formulae, or the divination of blemishes and dust-particles on the console (or anywhere else!) would in some way be predictive or instrumental in solving the problem. Of course there *are* ways of obtaining reasonably credible tentative answers to these *meta*-problems; but the point to be made here is that such answers should not merely be taken for granted.

144

(The above reference to confusion over the significance of dust-particles and blemishes was metaphorical, and referred to the *social* question of scientific method; but of course such confusions are encountered literally in schizophrenic patients, and as we shall see below, this is probably no mere coincidence).

### C1.3 Discrete modelling of "continuous" reality

We also encounter a second complication as we move from Ashby's example to most cases of scientific research, at least in the macro-phenomena which we can "observe" (in the normal sense of the term). As Weiss (1969) puts it: "Nature presents itself to us primarily as a continuum". Even though our scientific problems may well amount ultimately to operating 'on/off' mechanisms at some micro or ultramicro level, it will probably be beyond our power to treat such mechanisms like normal switches (or perhaps even to prove or disprove their existence using normal criteria) so that we may have no option but to use gross statistical manipulations and/or measurements in practical transactions. (Moreover we cannot be certain that the basic elements of any system will really be discrete and atom-like, though <144> it seems likely that such elements will at least be meta-stable centres of concentration within a continuum).

145

Despite such continuous properties manifested by the reality which we set out to study, it seems to be the case that most or all "*satisfactory*" scientific explanation needs to be expressible in discrete terms. Smooth curves, for instance, are "most satisfactory" when expressible in terms of finite series of polynomial, trigonometric, or other standard functions. Fortunately however, natural phenomena are generally "well behaved" in this respect — exhibiting properties which *can*, in principle, be simulated extensively at the observable level by an appropriate choice of discrete elements at the micro-level in the model, whether or not these correspond to the *actual* micro-structure of "the real system".

Alchemy was a mystic *art* which, as it developed into Chemistry, acquired some semi-satisfying explanations when its regularities at the observable level were summarized *approximately* by Mendeleev's periodic table; but adequate "understanding" had to wait for the atomic theory — to provide a micro-structural basis. As a surprising contrast, the explanation of gravity has rested at the observable-scale of formulation (despite Newton's own misgivings!), presumably because the inverse-square formula is so reliable here that we become conditioned not to press too hard for a "proper" explanation. And the same applies even more startlingly to that extraordinary formulation of our own century: the wave-particle dualism concept which is expressed in strange abstract formulae. This formulation has produced spectacular results like atomic energy, to be sure, but no satisfactory "explanation" in the sense of fundamental "understanding". (Popper, 1963).

It would probably be fair to say that the alchemists were slow to produce proper understanding because they lacked <145>

- (i) an adequately systematic methodological approach, and
- (ii) an adequate feel for the underlying micro-structure which might conceivably exist within their chemicals;

and the same might be said of Medicine before Pasteur and Koch. In both cases, this shortcoming may be seen as a failure to conceptualize adequately in discrete terms — indeed we may suspect that such a rudderless groping for structure is a nearly-inevitable precursor in any new field of enquiry. In such an environment, superstition is likely to surround the particular area of ignorance — perhaps despite general enlightenment on other topics. That is to say some sort of ad hoc structure is likely to creep into unstated assumptions, as a means towards papering over the nagging cognitive dissonance. While such ad hoc structures remain unrecognized as being only provisional, they are likely to form a serious obstacle to the elucidation of truth however valuable they may otherwise be as "stop-gap" theories.

But note that this danger of 'getting stuck with' a misleading model of reality (without realizing what has happened), is not confined to the models we construct of chemicals or neural elements; the danger also applies to the methodological rules which we use to constrain ourselves from using hopeless strategies like Ashby's first example. But these methodological rules are not infallible, and they too can serve as superstitious obstructions to truth-seeking — even if they simultaneously prevent us from setting up other obstructions lower down the hierarchy. In fact it seems likely that the "methodological superstitions" would be the more insidious in that they are less likely to be noticed for what they are. If this *is* the case, then we would do well to spend some effort to re-check the status and credentials of our rules for Scientific Method from time to time, or perhaps even relax them occasionally in the spirit of (controlled and monitored) adventure. <146> It might even be fair to say that this is the chief value of responsible *clinical* evidence, leading to such fresh insights as those of Freud, Laing, Tinbergen and Konrad Lorenz, and the 'diary'-observations of Jean Piaget; so those who have criticised such work on the basis of 'laboratory criteria' have not necessarily helped the cause of science as much as they might suppose.

This of course brings us back to the point (raised in the middle of Section C1.1) that the current doctrine favouring direct-testability is open to criticism. To elaborate a little on the earlier comments: it seems that, in practice, this doctrine means that only those novel theories which can be 'fully developed' within the space of one paper (or perhaps one book) are likely to be taken seriously; (where 'fully developed' means concluded to the point that decisive experimental tests are feasible). Not only does this tend to exclude useful heuristic developments, but it also tends to rule out those theories which cannot be 'fully developed' within the arbitrary limits imposed by the single paper (or book) format, no matter how well the theory fits the alternative criterion of internal consistency (Traill, 1976c). This may therefore be taken as an argument in favour of

*altering the rule* so as to include the internal consistency criterion — *and* for keeping such rules under surveillance generally.

#### C1.4 Apparently-continuous modelling of apparently-continuous reality: “Scientific Impressionism”

Let us first consider the implications of apparent-continuity in the “reality” under study. One approach is to adopt the Newtonian technique of discrete-symbolism-for-continuous-phenomena and hope that reality does match the models provided by integral and differential calculus. Any success here will automatically provide empirical predictive power; but it is open to question whether this really contributes to our fundamental *understanding*. <147>

Alternatively we may do our modelling stochastically, using a large population of micro elements or events, such that a statistical simulation of macro-reality may be hoped for, whether or not we wish to claim any validity or homomorphism for these *micro*-aspects of our model. For instance, suppose that we had no clear concept for a circle or how to reproduce one; how then could we approach the problem of communicating the concept between us? Well, we could say: “it’s a bit like a square (in all its orientations), a bit like a pentagon, ...”. If we were then to superimpose line-drawings of all these approximations, this would ultimately result in a tolerably identifiable *impression* of a circle. 148

It is here suggested that our concepts of ego, superego, schizophrenia, and indeed most of the concepts used in the psychological sciences, are of this impressionistic type. Similarly we might perhaps say that the various alternative theories of psychoanalysis, used pluralistically by clinicians, are analogous to the square and pentagon (etc.) of our above example. Thus none of them would be strictly correct, yet a judicious choice might result in the clinical use of a particular approximation which is optimally suited to the particular patient at a particular time. And a suitably mixed “superposition” of these theories might sometimes give a good overall “feel” for the real phenomenon as a whole.

We do ourselves less than justice if we decry the value of such “unscientific” techniques (which are significantly similar to ‘primary-process thinking’), but neither should we be content to rest on our laurels. If there is any prospect of building a model which is sharper than our present impressionistic one, a model capable of incorporating the various “straight-line figure” approximations into one improved “circle” formulation, then it would seem prudent to try. (Planck’s reconciliation of Wien’s law and the Rayleigh-Jeans law is perhaps <148> a more pertinent example, (Slater, 1955, Chapter 3)). If such a formulation cannot at present be supported by evidence or immediately foreseeable experimentation, then this is unfortunate — but not catastrophic so long as we do not forget its *tentative* status, and so long as it shows ‘internal closure’ within its interdisciplinary implications (like its close cousin ‘secondary process thinking’). 149

It was to this end that an unobserved ultra-micro structure was postulated for the Piagetian impressionistic concepts of “scheme” and “schema” (Part A, above); and also further postulates were introduced to improve the interdisciplinary internal-closure by removing some more “somehow”s from the general formulation, (Part B, above; and Traill, 1976b). It is now proposed to apply these concepts to more general activities of the human brain, both in the hope that the results will find practical application, and as an effort towards a further extension of interdisciplinary internal closure. <149>



## Chapter C2

**A Brief Review of the Neo-Piagetian Linear-Molecule Theory of Brain-Function**

## SUMMARY OF CHAPTER

This chapter serves mainly to draw together the main ideas put forward in the present work so far, in preparation for their impending use in postulating the more elaborate structures and processes which are presumed to give rise to behavioural phenomena.

We start by reviewing the essential points of the “linear micro-element” basis postulated for memory, which differs from the pure neuron-synaptic view in the much greater information content which it permits, and in its ready-made organization into linear sequences — and yet offers a new basis both for precision and for flexibility. We also recall the notions of how each individual may reconstruct reasonably faithful models of basic reality by seeking grouplike properties amongst his elementary sensori-motor concepts — seen as physical encodings. This leads to the question of elementary “symbolic” thought (without full external action), and a likely role for sleep.

In addition the question of “levels” of mental organization is brought up again, and formalized a little more by the introduction of the “**m<sup>n</sup>I**” notation.

**C2.1 The fundamental physical basis**

The essential point is that synaptic changes are no longer seen as all-important elements for memory or for hereditary reflexes, but are augmented or even replaced by supposed coding activity at the molecular level. Molecular coding is thought of as a linear sequence of coded sites — as in DNA, RNA, or linear protein — which are set up in such a way that they can be *rapidly* “read out”, thus activating other such molecules or triggering specific items of motor activity. Individual molecules would probably not be capable of producing manifest observable activity on their own; but could only be effective if and when they found “agreement” from a sufficient *population* of similar molecules, with which they would also have to have some sort of coordination mechanism —<150> probably along the lines of Monod and Jacob’s biochemical coordination model, “Model IV” (1961). (Traill, 1975b, 1976d).

Sites along the molecular strings were seen as falling into two main types and a subsidiary type. The *label* type would await appropriately coded signals from outside the molecule before they would do anything, and in general they would probably also need to have been primed by an internal signal within the molecule before they would start to “listen” for the external messages; so they would normally serve as ‘and’-gates thus: “Have I recently received a nudge from my neighbouring site, *and* have I the specific go-ahead from outside? If so, then I must nudge my other neighbour to set him going in a similar way.” Phonon or exciton transmission seemed to offer a sufficiently rapid method for relaying the “nudges”, and the external messages were seen as emission-and absorption radiation, which implies infra-red for macromolecules of the type envisaged. (See Chapter B2, above).

Whereas the first main type of site served as a tuned<sup>28</sup> receiver for specific external signals, the second was seen as a *transmitter* of such signals (along with the sense-organs, via their proximal representatives). The second type would also normally pass on the “nudge” without question. The transmitted signals were seen as having various functions: motor, controlling

<sup>28</sup> It should not be imagined that this is a simple tuning in the sense of a fixed-frequency sensitivity like a radio morse-receiver. It will instead, almost certainly depend on *patterns* of signal input which will be more like ordinary (complex) speech waves, highly dependent on sequence (like a combination lock), and rather less definable in terms of sinusoidal functions. (See Chapter B2 above, and again later on in Section C6.7). <151>

internal activities such as sense-organ parameters and aspects of attention, “subprogramming” calls to other relevant types of molecular coding, and <151> synchronization of the population of similar molecular codings. (Whether or not this account is correct, it does at least bring into the open the question of explaining just how chemical memory-traces and electrical signals might conceivably interact in detail).

152

The concept of infra-red signals being transmitted across appreciable distances leads to some troublesome problems due to the formidable absorption characteristics for water in this region of the spectrum. One conceivable solution would be for the infra-red coding to become “translated” into and out of orthodox action-potential coding, though it is by no means clear how this might be achieved on the basis of conventional theory, and it seems inevitable that huge losses of information would be entailed by such a procedure. An alternative suggestion (Traill, 1975b, 1976b; also Chapters A3 and B3, above) arises out of a close analysis of the physics-theory of saltatory conduction of electromagnetic signals along myelinated nerve-fibre segments. It emerges from this study that such dielectric pathways would be eminently suitable for conducting infra-red along the distances envisaged, *provided that* a moderate amount of protection from the absorption effects of water is available. It would seem that there are several plausible ways in which this moderate protection could be provided, and moreover the idea can plausibly be reconciled with action-potential phenomena by considering the latter as massed effects in which infrared-scale pulses or waves are an important component. The infra-red hypothesis may therefore be provisionally accepted on the basis of its internal consistency (see Chapter C1), pending external evidence more convincing than the fragments currently available.

## C2.2 Learning and the sensori-motor period

As for the learning process, it is remotely conceivable that experience is “recorded” on such linear molecules in the manner of <152> a tape-recording. But until some plausible mechanism is suggested, we would do better to take Piaget’s concept of *action first, then learning* to its logical conclusion and suppose that *all learning* must first await spontaneous elaboration or “genetic crossover” at the molecular level — on a trial-and-error evolutionary mutation basis; (Traill 1976b; also Parts a and B, above). Any such embryonic idea which appears to be adaptive will then be “reinforced”, while others will be re-dissolved or mutated further. Just how such reinforcement might take place is a matter of some importance, and two possible mechanisms have been offered, though so far even the internal-closure support for them (in the public-knowledge domain) leaves much to be desired. Provisionally however, we may accept them both as working hypotheses.

153

The first mechanism is seen as a rather abstractly described seeking-after-internal-consistency, or a trend toward “mathematical groups”; (Traill, 1975b; and Chapter A3, above). This means a striving towards ‘*internal closure*’, so its successes-or-failures appear to entail their own “pleasure-or-pain” in what is usually taken as a metaphorical sense, but is here taken rather more literally.

The second mechanism involves normal concepts of pleasure and pain; and thus, in the main, serves the cause of ‘*external closure*’ — i.e. keeping the mental models more consistent with the reality outside. For this, we suppose that there is a supplementary type of molecular site which can become (reversibly?) appended to the molecule according to the ‘satisfaction state’ of the organism at about the time that the particular molecule was last ‘read’. Those molecules with a ‘positive’ tag would tend to be immune from attack and/or be eligible for replication, while a ‘negative’ tag would amount to an “outlaw”-label; (Traill, 1975b). These tags might also be involved in subjective feelings of pleasure or pain — <153> or alternatively there might be *other* similar tags for this purpose, which would normally operate in parallel, but could fall out of line under some circumstances thus producing anomalous effects.

154

Linear codings of this sort are seen as accumulating sufficiently for them to produce observable behavioural effects, in which case they would appear to coincide, collectively, with Piaget's concept of a "scheme" — either hereditary or learned. They may also be closely related to the concept of Short Term Memory, though that is of less immediate relevance. With continuing use, such an ensemble appears to acquire stability and permanence for reasons which are not entirely clear, though increasing localization and the concentrations of mutually-supportive cross-feed (from similar elements within a closely-knit population) do offer one likely explanation; (see Section A3.8, above). Anyhow, such a stabilized and quasi-permanent scheme is referred to as a "schema" (plural "schemata") following Piaget's terminology, even though his usage is confined to what we shall regard as a *similar consolidation* during the following "Operational Period" (Furth, 1969). Here we shall use the same term for both periods, and also for the two sub-periods within each, for reasons which should soon become apparent. (For both these periods, and others, it is tempting to relate the schema concept to the notion of *Long Term Memory*; but as before, there is no need to labour the analogy here).

Mental development of the first type (the one seeking internal group-structure) depends on some degree of lawfulness or consistency in the external environment which it is trying to model. Similarly we might expect that any "introspectively directed" attempts to classify or control one's own thought-elements would be doomed to failure until such time as these thought elements showed some potentially-discernible pattern. With the consolidation of a <154> sufficient number of the primitive schemata (such as: "Given situation-perception a, and desire-state (c), then the thing to do seems to be action b"), then it becomes feasible to classify such schemata into *sets* — and ultimately into *mathematical groups* (Traill, 1975a; and Chapter A3, above).

155

### C2.3 Internal reference 'by name': sleep, mathematical sets, and the "m<sup>n</sup>l" hierarchy; implications for decision-making behaviour

Given a substantial repertoire of pre-coded patterns of activity, including integration arrangements between them similar to 'subprogramming', then it would only take some minor modification to the key 'call-sign' coding (which would normally activate the ensemble) to *suspend* the actual execution of the action implicit in the ensemble. Such a modification serves to convert the 'call-sign' into a detached 'name' which is then available for use as an abstract symbol for the action which has now been deferred; and this is accordingly a likely material basis for a primitive mental 'concept'.

It is of some importance to consider the nature and implications of such suspensions of execution. Presumably they must often be convertible so that 'at the flick of a switch' certain abstract thoughts can be converted into the real action to which they correspond; but if so, then we would do well to have some idea about how such 'switches' might be controlled. Without going too deeply into this question, we might list several possibilities:- a comparatively minor *modification to the call-sign* might distinguish the 'symbolic' from the 'real', (and such a modification might be analogous to a grammatical change of vowel as an indicator of tense). Alternatively '*tags*' might well be involved in the modification of the actual encodings (as opposed to the call-signs which are presumed to activate them).

Then again *sleep* would almost certainly be involved in some way, <155> possibly by changing the *overall* criterion as to what is to be executed and what is to remain symbolic and abstract. This raises some intriguing and complex possibilities relating to the different modes of sleep — and perhaps also various drug-induced states. Consider for instance: (a) the suppression of general muscle tonus during REM sleep, (b) the increased incidence of REM sleep with position in the phylogenetic scale, and (c) its dominance (to the exclusion of "orthodox" sleep) for neonate mammals, (Jouvet, 1967). We will come back to some of these issues in Section

156

C6.4, and again subsequently as part of the discussion of the psychotic symptoms arising from sleep deprivation, (Section C8.4).

Anyhow, the development of name-codings<sup>29</sup> for stable primitive action patterns now makes it feasible for ‘higher-order’ scheme-elements to evolve. These may be thought of as linear *lists* containing ‘name-codings’ for lower-order schemata (and hereditary schemes).

This new development constitutes the first step up an extended hierarchical ladder, so it would be well to introduce a naming-system for the various levels. What seems here (rather naively as we shall see) to be the basic level containing the elementary schemes of sensori-motor development — will be referred to as the “ $m^0l$ ” level. (The terminology here is intended to be roughly compatible with that of mathematico-logic/linguistics, in which  $L$  represents the basic “language”,  $ML$  represents the “meta-language” within which  $L$  may be discussed,  $MML$  stands for the “meta-meta-language”, and so on. In fact though, this traditional notation will be seen to correspond a little more closely to the somewhat <156> broader categories inherent in the “ $M^nl$ ” notation, which will be introduced below in Section C3.2). The *new type* of scheme-element which we have just introduced as “lists” for the basic elements will be referred to as being at the “ $m^{1/2}l$ ” (sub)-level, where the fraction conveniently implies a qualitative difference from both  $m^0l$  and  $m^1l$  (which roughly corresponds to the traditional “ $ML$ ”); and of course the fraction also implies the postulated position for  $m^{1/2}l$  as being *between*  $m^0l$  and  $m^1l$ .

157

The setting up of such  $m^{1/2}l$  lists or *mathematical sets* might plausibly take place by a process such as the following<sup>30</sup>. Firstly we need some mechanism for producing a “blank note-pad” on which the acquired lists can be “written”; where we may assume that these “note-pads” are linear scheme-elements similar in principle to those of  $m^0l$ , but containing internally-directed references to the  $m^0l$  schemata or hereditary schemes rather than to externally-directed actions. Such blank scheme-elements might be provided ready-made as part of the hereditary legacy, or they might be the result of arbitrary accretions combined with a selection process, and/or they might be produced by *converting* some of the  $m^0l$  elements either by ‘inactivating’ their references into ‘names’ — or by some sort of (gradual?) replacement of sites along the linear string.

So suppose that, by some such means or other, we now have blank or “inadequately coded”  $m^{1/2}l$  linear elements available in sufficient numbers; how could these be developed into usable mathematical-set concepts such as “the set of all schemata which seem to lead to my hunger being alleviated (given initial conditions ‘so-and-so’)”? In view of the postulated mechanism for the  $m^0l$  scheme elements, it seems likely that the  $m^{1/2}l$  elements will similarly <157> contain some sort of coded *expectation* about the properties of its listed ‘members’; and such an expectation would amount to an intensive<sup>31</sup> definition of the set. Conceivably this expectation might simply be implicit in the existing list, at any given instant, as some sort of consensus property. But pending a satisfactory explanation of how such a system might work in detail, we may consider the alternative that the  $m^{1/2}l$  elements contain an explicit coding of expectation — albeit arbitrary. (This might result, for instance, from the ‘promotion’ of  $m^0l$  elements — as these will presumably already contain a coding for consummatory expectation, even if this is not qualitatively appropriate as it stands). It is not clear just how many members there could reasonably be on a

158

<sup>29</sup> These should *not* be thought of as being linguistic names in any literal sense; indeed we have so far been discussing pre-linguistic infants, in their first year <156>

<sup>30</sup> More detailed explanations will be given in Section C5.2 and in Section C8.1, but this present generalized account will suffice for our immediate purposes. <157>

<sup>31</sup> In Piagetian usage, an *intensive* definition is a *description* of set members against which any potential member can be assessed to determine whether it is actually allowable as a member or not; whereas an *extensive* definition amounts to saying “all objects within this boundary” (or “all phenomena within this time-interval”) etc. <158>

given list element, though it is tempting to see a connection with the concepts of ‘chunking’ and ‘the magic number  $7 \pm 2$ ’ (Miller, 1956a, 1956b); but the effective list at *behavioural* level might gain extra scope using a *population* of *less complete* elementary lists, used redundantly.

But given that these  $m^l$  elements have some coded “expectation” concerning any members to be listed on it; how could it come about that the members *are in fact* of the type “expected”? (I.e., how is it that the “extensive definitions” happen to coincide with the “intensive definitions”?). At first sight, one might expect the list to “search” (somehow) for suitable members whose ‘names’ might then be added onto itself; but this is another case of an anthropomorphic model which we would do well to set aside until a detailed explanation of it, in mechanistic terms, should happen to be forthcoming. <158>

Meanwhile let us suppose that ‘names’ of members are added to the list more-or-less at random, and that it is then the job of ‘the system’ to *correct the resulting errors-of-commission*. It would not be too difficult then, to imagine some sort of automatic rehearsal procedure (perhaps during one of the sleep-modes) in which the coded “expectation” for the list was to be compared with the relevant properties of the named members. Whenever there was a mis-match we might suppose that the whole list might be liquidated, or else all ‘names’ could be erased from the encoding, or perhaps only the name of the offending member would be erased; (these alternatives being in order of ascending efficiency). Once again it is worth commenting that the huge redundancy possibilities which result from the present molecule-based model, make it feasible to contemplate such apparently inefficient mechanisms and to use them as an alternative to anthropomorphic or teleological “ghosts in the machine”.

One consequence of this development of set-constructing ability is likely to be the capacity for using elementary strategies for problem solving. Consider the general situation (Siegel *et al.*, 1964; Wetherick, 1977) in which the individual must choose (repeatedly) between two alternatives which we will call *A* and *B*. If *A* happens to be the appropriate choice in, say, 75% of choices (while *B* is correct for the remaining 25%), then the “rational” strategy would be for the Subject *always* to choose *A* — that is once he has had enough experience of the situation to appreciate the nature of the random factors involved. However this “rationality” requires a comparatively sophisticated mental organization, so some animals are unable to operate at this level; and those that can, such as humans, will not necessarily do so under the given circumstances — for one reason or another.

In the absence of this rational strategy, the individual seems <159> to use the less efficient technique of frequency-matching; that is to say he ends up selecting *A* for about 75% of his choices, distributed in an approximately-random fashion — thus matching the frequency inherent in the phenomenon itself. In terms of our present molecular model, this can be explained in terms of the degrees of reinforcement for the two types of action and their respective molecular encodings. Those coded elements instrumental in the choice of *A* will receive more support, and will consequently come to be represented by a larger population of molecular encodings, while the pro-*B* elements will also receive modest amounts of support and will thus build up their own relatively-modest population. In any actual choice then, the two populations will presumably compete to provide the effective program for action; and it will literally be “the luck of the draw” as to which one will succeed in any given instance. But note the important point: *no special set-organization appears to be necessary* for this process.

Fish apparently operate at this primitive level, but rats are capable of evolving toward the “rational” strategy of always choosing that single alternative which has the best average payoff (Wetherick 1977, citing Bitterman), and this superior capability seems likely to be due to an ability “to envisage something that is not present in the immediate perceptual environment”. But for the rat to be able to realize on this inherent ability, it needs to be “allowed to approach the

correct discriminandum even if it chose the wrong one initially” — and it would seem that some sort of set-organizing mechanism must be required if these *two* exploratory probes are to have their information *integrated into one* usable scheme, this being some sort of an appreciation of the selection situation as a whole rather than the mere blind impulse that a certain response should be made. Anyhow it would seem likely that Wetherick’s <160> *second level* corresponds to the  $m^{1/2}$  level proposed here, and indeed his *third level* which “involves ability to identify differences and similarities between present states of the environment and past states ... [and hence relates to] language” seems to be identifiable with the  $m^1$  level and its presumed power to manipulate the  $m^0$  and  $m^{1/2}$  elements (as discussed below).

161

Note that even human subjects may be caught out using the primitive frequency-matching strategy which we have just considered (Siegel *et al.*, 1964), though here the result is bound to be more difficult to interpret because of the confounding influence of the third level ( $m^1$ ), and probably other levels as well — as we shall see. However one plausible explanation for Siegel’s results is that the subjects used the primitive strategy because something in the experimenter’s instructions, or the cultural expectations implicit in the situation, led them to believe that this was what was required of them. Thus possibly they operated under active ( $m^1$  ?) schemata, which served to *suppress* any relevant  $m^{1/2}$  activity, so that the primitive  $m^0$ -based “lottery”-approach was left as the one which actually operated on the problem.

The notion of a negative instance raises some complex issues which we will not go into fully here, but we should bear in mind that a concept and its specific negation actually have much in common (Freud, 1900). This suggests the need for a set-like structure to link them both, and probably an extensively defined set-structure at that — though perhaps this would take time to evolve itself. Similar things might also be said about conjunctive concepts (Bruner, Goodnow, and Austin, 1956), and it is likely that their reported increased difficulty with *disjunctive* concepts arises due to a need to call on further organization higher up the  $m^n$  scale.

Anyhow provided that extensively defined mathematical sets <161> (or “lists”) can be established for any conceivable common-criterion (intensive definition), then it becomes feasible to explain a possible mechanism for the mental development and retention of “mathematical groups”, or more normally — *group-like* concept-structures. We may now turn to this topic and elaborate on the ideas expounded in Chapter A3 (above), and illustrated in Traill (1975b).

162

#### C2.4 Trend toward mathematical groups in the later sensori-motor period

This turns out to be a matter of formidable complexity if we try to trace the probable course of real-life developments in any detail. For our immediate purpose it will suffice if we look only at a few simplified or idealized cases; but it should be born in mind that a real brain system must cope with the complexity as it actually occurs, thus making heavy demands on its structural capabilities and redundancy reserves. Anyone attempting to build a computer model to simulate such activities would also do well to ponder the “hardware”-implications quantitatively before becoming too involved.

The most convenient example, already discussed in some detail (Chapter A3, above; Traill, 1975b), is the geometrical-spatial task of learning how to find one’s way around a (topological) square in which the “corners” correspond to recognizable and distinguishable events or phenomena, and at least one of these is inherently rewarding — and so worth trying to attain. Voluntary reversibility was seen as arising as a consequence of a change of the individual’s “drive state” (e.g. from hunger to thirst) in such a way that a *different* corner of the square became attractive. In this way, all the appropriate  $m^0$  schemata could develop, thus enabling the  $m^{1/2}$  “lists” (relevant to transactions with the square) to achieve exhaustive completeness — or something like it.

But there are many ways of conceptualizing a Euclidean square, and likewise there are many ways of viewing other similar “topological <162> quadrilaterals”, both literal and metaphorical; and the same argument applies in principle to the learning task for each of them. Even if we look no further than the “corners”, it will be of practical value to distinguish different subsets taken from the complete set of possible moves between one corner and another. We may usefully keep a list of schemata for “diagonal moves” (only), or for “clockwise moves”, or for “routes towards corner  $x$ ”, etc.<sup>32</sup>

163

Yet there is still another, less obvious, complication. Our view of an *observed* square as having group properties is partly conventional<sup>33</sup>. Consider what happens when we have to scan the “corners” consecutively *and* we also judge each corner as having an absolute time-based property, then we can never return to precisely the same corner again (though we might be prepared to accept “an approximation”, more-or-less consciously). Thus, depending on our criteria, a conventional group-like thing will not always be perceived as a group. <163>

So it would seem that even the “ideal” group-like nature of rigid geometrical bodies is, to some extent, just a construct of the mind — made for the sake of pragmatic convenience. But in any case, for other more “fuzzy” macro-manifestations of structure such as *Mr X’s personality*, it becomes quite obvious that any group properties which we might attribute to such “things” will always fall short of perfection; (and this will apply to our social “scientific knowledge” models, as well as to our concepts as individuals). In fact this presumed strategy of “aiming at groupness, but being prepared to settle for the best available approximation” seems to work very well on the whole. Errors will often be irrelevant for practical purposes (even if their existence comes to be recognized), or they may simply be corrected as the occasion demands. There may however be problems when one such partially-correct grouplike model becomes enmeshed in another, and when the resulting structure has become instrumental in maintaining the stability of the individual or the society. Thus trivially-inappropriate associations may give rise to neuroses or (socially) a Galileo may have trouble correcting a mistaken cosmology when it becomes enmeshed with religious doctrine due to historical and political reasons rather than “rational” reasons. <164>

164

---

<sup>32</sup> Moreover we will probably need a *list of these lists* if the individual is to keep track of the fact that the subset lists are fundamentally related to each other — unless this could be done in some other way such as overlapping memberships see Section C8.1. Then there may be some value in associating these schemata with those for the concepts of “rectilinearity” and/or “perpendicularity” — almost certainly more difficult and sophisticated than would appear at first glance. Next there might be concepts for “midpoint of side” or “middle of square”, and so on — though *not* indefinitely. Thus, for instance, there would normally be little point in developing a (non-numerical) schema for a concept which amounted to “17.87% of the way along a side”.

<sup>33</sup> Such a view is based on pragmatic grounds which are suggestive of the truth, but do not absolutely prove it. (This is a “hair-splitting” distinction in the present example, but in general it will *not* be).

&lt;163&gt;

## Chapter C3

**Abstractions, or Thoughts about Thought-Constructs: Is the Process Recursive ?**

## SUMMARY OF CHAPTER

Within the discussion of mind-brain organization, this chapter introduces the mathematical concept of recursion, i.e. the re-using of the same basic organizational procedure repeatedly (but at different levels), so as to build up a hierarchical organizational structure while also allowing simplicity of design and standardization of basic resource units. This is seen as a possible explanation for Piaget's stages, and it also seems to fit in with Ashby's ideas of double-or-multiple feedback loops.

**C3.1 The concept of mathematical recursion, and some variations on this theme**

As an explanation of the recursion concept, consider the mathematical function "factorial  $n$ " (written as " $n!$ "), where

$$\begin{aligned} [0! &= 1], \\ 1! &= 1, \\ 2! &= 2 \times 1, \\ 3! &= 3 \times 2 \times 1, \\ 4! &= 4 \times 3 \times 2 \times 1, \\ &\dots \\ n! &= n \times (n-1) \times (n-2) \times \dots \times 2 \times 1. \end{aligned}$$

A function such as this can readily be specified by a recursive algorithm, which in this case would be:-

(A) Take the value of  $n$  and 'write it down' in some accessible place called 'memory' (specific to *this particular* entry into the algorithm, see below).

(B) Make sure that  $n$  is neither negative nor fractional; otherwise give up and signal that an error has occurred.

(C) 'Write' "1" into another position called 'answer' (which must also be specific to this particular recursive "level").

(D) Test whether 'memory' now contains "0", and hence choose <165> whether to do E or F:-

(E) If  $n$ , the number in 'memory', has a value of 1 or more, then multiply the 'answer' by this number, and also by  $(n-1)!$  — which will entail a *recursive* repetition of the whole procedure "at a different level of operation" (with a new value for  $n$ ), and there will ultimately be many such levels whenever there are high values of the original  $n$ . When this task has been done, the next task is determined by 'exiting' back to wherever the immediate request for a factorial evaluation came from — whether within the same recursive series or not.

(F) If the  $n$ -value in 'memory' is zero, then accept 'answer' in its present form (= 1) as being the result for *this* recursive level, and pass this result back to wherever the immediate request for a factorial evaluation came from (either the "abstract" previous level of recursion, or the original "real-life" problem), and also return to this same place to find the next instruction.

Equivalently, this algorithm may be written in ALGOL:-



**integer procedure** factorial(n); **value** n; **integer** n;

**begin**

**integer** answer; **comment** The “integer n” sets up a new memory-location for each successive recursive entry into this subroutine, and stores the nominated value in it ready for use. The answer location is also set aside, but with no reliable pre-set value;

**if** n<0 **then goto** ERROR; **comment** n has already been made an integer;

**if** n=0 **then goto** F;

E: answer:= n \* factorial(n-1); **comment** recursive call;

factorial:=answer;

**goto** EXIT;

F: factorial:=1; **comment** Basic simple case, no (further) recursion;

**goto** EXIT;

EXIT:

**end** of factorial subroutine (this time round); <166>

The details of this particular example are not important here, and indeed their relevance is somewhat limited; but there are nevertheless several useful concepts to be drawn from the example, or from others like it (Barron, 1968). (a) Firstly the method may be seen as a “trick” whereby a complex operation, of unpredictable magnitude, can be carried out by a compact repertoire of not-very sophisticated actions: simple multiplication, subtract 1, identify 0 and error conditions, keep basic records, transfer results, and the ability to “pass the buck recursively”. It has been suggested above (in Section A3.11) that a similar sort of recursion between levels may be operating in connection with Piaget’s stages of development; though here the limited repertoire of available actions would include those involved in *set* and *group* construction, and also the ability to “handle” such constructs — or at least those produced at lower  $m^{\text{nl}}$  levels. It is not suggested that the brain can necessarily cope with a denumerably infinite number of levels, as *seems* to be the case with the factorial-function example. In both cases there will necessarily be a practical limit to recursive processes; though in the case of the brain it is not yet clear how such limitations would be likely to operate. It will perhaps be evident from the system proposed above in Section C2 that an important difference between it and the “factorial” algorithm lies in the method of “passing the buck” to the next level. In the brain-model, the lower level is “at a loss” and is only rescued if-and-when the upper  $m^{\text{nl}}$  “interferes” arbitrarily in the right way.

(b) In both cases there is an indispensable “ground-floor” level which comes closest to being in contact with the “real world outside” — on an actual transactional basis. In the factorial-algorithm, this level is the one which actually performs the final stage of the calculation and passes the result back for the benefit <167> of the computer program in which it is embedded — this being its “outside world”. In the case of the brain-model, as we have seen in Chapter C2, the lowest level was postulated as being  $m^{\text{0l}}$  — the basic part of the sensori-motor double level. (Later on, in Section C5.4, it will be suggested that the basic level is actually lower than this — at an “ $m^{-1l}$ ” or “ $M^{-1L}$ ” level).

(c) In both cases there is also, in some sense, an upper level. Obviously some degree of flexibility is called for here, so it may not always be clear where to locate this “top floor” when the system is diffuse — as envisaged in the brain model. In the “factorial” case, the “top” will always consist of a mere allocation of the answer “1” (in response to the problem: “evaluate 0!”);

but in view of the postulated *downward* direction of initiative-taking for the biological brain, the significance of the current top level will presumably be radically different for the two cases. In fact it has been tentatively suggested (Traill, 1976d) that the top level may be intimately involved in the phenomenon of *consciousness* for the case of the brain model; and after all, the “top” is seen as a unique source of initiatives which exert decisive control over some activities of the other levels.

(d) a purely recursive process may be thought of as re-using the *same material mechanisms* for each successive level of its “calculation”, as is clearly implied in the above ALGOL example. However it would be perfectly possible to re-write such a subroutine such that different mechanisms are used for different levels. For instance it would not be unreasonable to treat 0!, 1!, 2!, 3!, and 4! (say) as special cases in which it is, on the whole, easier to simply “remember” the answer ready-made (as being 1, 1, 2, 6, and 24, respectively). The calculation for higher values would then terminate with the “evaluation” of 4! as being at the top of the <168> hierarchy instead of that for 0! as was used above in the pure case. This sort of change in methodological procedure according to hierarchical position or complexity is fairly common in a non-computer daily context, and may perhaps be illustrated below by the second way of writing out the following formula for an infinite series:-

$$e = \frac{1}{0!} + \frac{1}{1!} + \frac{1}{2!} + \frac{1}{3!} + \frac{1}{4!} + \frac{1}{5!} + \dots$$

$$e = 1 + 1 + \frac{1}{2} + \frac{1}{3!} + \frac{1}{4!} + \frac{1}{5!} + \dots$$

And moreover it should be recognized that there are practical advantages in such a corruption of the purity of the formula; — though there are disadvantages as well. Ultimately the “efficacy” of such a mixed methodology must be judged according to the context of its likely use.

In the brain-model as described so far, we have considered two supposedly separate levels (active within the sensori-motor period):  $\mathbf{m}^0\mathbf{l}$  and  $\mathbf{m}^{1/2}\mathbf{l}$  — the first dealing with internal codings for direct primitive interactions with the outside world, and the second dealing with sets and groups of the former. It would not be unduly surprising if these two levels of activity were to find their physical embodiments in linear elements which were strictly allocated to the one *or* the other, and not freely available to both — in the short term at least. Nevertheless, it would seem likely that these two types of coding should be spatially close together for easy communication and control; and being *populations* of elements, this would presumably mean that the two types of element would be intermixed within whatever regions of the brain happen to be involved.

### C3.2 Estimating the likely scope and nature of recursion in the brain

It was suggested previously (in Chapter A3) that consecutive recursive levels correspond to the *sensori-motor*, *concrete operations*, <169> and *formal operations* periods respectively. It was also suggested that each of these levels has a two-tier subdivision; so that in each case, the lower tier was concerned with the relevant type of “primitive” element (as for the  $\mathbf{m}^0\mathbf{l}$  level) while the upper tier was engaged in forming sets and groups (as for the  $\mathbf{m}^{1/2}\mathbf{l}$  level). Logically then, there would seem to be at least six such sublevels in use in adults:  $\mathbf{m}^0\mathbf{l}$ -and- $\mathbf{m}^{1/2}\mathbf{l}$  (sensori-motor);  $\mathbf{m}^1\mathbf{l}$ -and- $\mathbf{m}^{3/2}\mathbf{l}$  (“concrete operational” in the wider sense, comprising “pre-operational” and the narrower sense of “concrete operations”, respectively); then  $\mathbf{m}^2\mathbf{l}$  and  $\mathbf{m}^{5/2}\mathbf{l}$  (for formal operations).

This postulated hierarchical series raises several questions as to whether recursion is really involved, and if so, then in what form. There is no immediately available means for supplying a confident answer to such questions, either from experimental data, *or* from ‘internal closure’. But if our general approach is correct then it will become a matter of considerable interest and importance to clarify such matters; mainly because many *malfunctions* are likely to be selective as to the physical mechanisms which they will affect, so that any mechanism which is shared by two or more levels is likely to cause *multiple symptoms* whenever it fails to work correctly.

For the sake of having some definite ideas to criticise, the following suggestions are offered as tentative working hypotheses. Any evidence for these postulates is no more than impressionistic; but the exercise should at least help us to a clearer concrete view of the problem, and it could plausibly lead us fortuitously into a model which turns out to offer unsuspected internal closure.

Let us first take the three double-levels as units and consider the relationships between neighbours. Now, according to our earlier tentative postulate, the  $\mathbf{m}^0\mathbf{l}$  and  $\mathbf{m}^{1/2}\mathbf{l}$  combined-level will collectively be the one most directly concerned with interactions with the outside <170> world (whereas the others are supposed to confine their control activities to internal entities). Also it is tempting to locate the  $\mathbf{m}^0/\mathbf{m}^{1/2}\mathbf{l}$  elements within the phylogenetically older parts of the brain, and the higher double-level elements within the neocortex (which, roughly speaking, starts to appear in animals which are capable of transcending sensori-motor limitations (Diamond and Hall, 1969). Anyhow on the basis of such impressionistic leads, let us postulate that (i) the  $\mathbf{m}^1/\mathbf{m}^{1/2}\mathbf{l}$  double-level (i.e.  $\mathbf{M}^1\mathbf{L}$ )<sup>34</sup> shares a common material substrate with the  $\mathbf{m}^2/\mathbf{m}^{2/2}\mathbf{l}$  (or  $\mathbf{M}^2\mathbf{L}$ ) double-level, but that (ii) the more basic and primitive  $\mathbf{m}^0/\mathbf{m}^{1/2}\mathbf{l}$  (or  $\mathbf{M}^0\mathbf{L}$ ) double-level has its own separate substrate, thus disturbing the “purity” of the supposed recursive activity. However even if the substrate *is* different, this does not of itself mean that the basic mechanisms of the different substrates will necessarily be different though of course that is a possibility; and in any case, drugs and other disturbing agents might well affect these substrates differently.

But this picture may well be too simple. Bearing in mind that we are dealing with a “parallel processor” (unlike the strictly sequential activities of a digital computer), and considering too that the initiative is supposed to come from the “top”, it is quite plausible to suppose that there may be several *alternative* substrates for any given level. We need not go into the ramifications of this here, but we should not lose sight of the possibility and its implications for potentially antagonistic mechanisms.

Neither should we assume that organization *within* any given level will be straightforward. Indeed we probably need look no further than the problem of developing the schemata for “three-dimensional <171> solid object” *on the basis of* previously acquired schemata for two-dimensional figures (Section A3.10, above), to see the need for some sort of recursive-like procedure within the  $\mathbf{m}^{1/2}\mathbf{l}$  level. Moreover the above remarks about parallel processing would seem to be just as apposite here.

As for consciousness, any suggestions can be little more than intelligently speculative at this stage. However it seems likely that, as a presumed source of “initiative”, it will have something to do with the “top level” whatever that is, (Traill, 1976d). This might reside in whichever level is currently developing, though anyone who has tried to carry on office-work whilst the business is gradually moving premises might be inclined to doubt the wisdom of such an activity. Instead, for the sake of the present discussion, let us postulate that: (iii) There will be a comparatively

<sup>34</sup> At this stage it is advisable to introduce extra terminology:

“ $\mathbf{M}^0\mathbf{L}$ ” as a collective name for the  $\mathbf{m}^0/\mathbf{m}^{1/2}\mathbf{l}$  double-level

“ $\mathbf{M}^1\mathbf{L}$ ” as the collective name for  $\mathbf{m}^1/\mathbf{m}^{1/2}\mathbf{l}$ ; and

“ $\mathbf{M}^2\mathbf{L}$ ” for  $\mathbf{m}^2/\mathbf{m}^{2/2}\mathbf{l}$ . <171>

stable top level, whose workings will not normally be accessible to the other abovementioned levels; but it will itself behave, in some sense, as controller over them as the occasion demands presumably the “source of initiative” which was considered above. One might perhaps think of this postulated controller as being a sort of  $\mathbf{M}^{\infty}\mathbf{L}$  level<sup>35</sup> a sort of *local approximation* to an “all-seeing” transcendental being. If such a “centre” does exist, then perhaps the reticular formation would be a promising candidate for the post.

Pure recursion, in the sense of re-using the same basic “hardware”, may well not extend throughout the whole  $\mathbf{M}^n\mathbf{L}$  scale; but provided that it does exist at the higher levels, this will have important consequences for the nature of abstract thought. It would <172> seem to make possible, in principle, a boundless series of levels of abstraction beyond mere “Formal Operations” — as implied in Section A3.11, above. Just how far this could be taken in practice is a moot point however. “In principle” one might well be “able to build a card-house up to the ceiling”, but to actually do so is quite another matter. The importance of “effort” and “ideal conditions” becomes increasingly intrusive the further one goes. Even in computer-run mathematical recursion one first encounters economic constraints, and ultimately technological constraints on the practical size of a recursion process; while in “biological recursion” one must expect much greater problems in view of the less formal and redundant organization inherent in such systems. <173>

173

---

<sup>35</sup> Concerning “ $\mathbf{M}^{\infty}\mathbf{L}$ ”, this issue is discussed in more detail in Section C6.4 (paragraphs 4 and 5), and is also raised again in Section C8.2 (paragraph 36). Meanwhile we should not take the numerical implications of the “ $\infty$ ” too literally — but only its topological implications. Indeed, to avoid misunderstanding, I propose in future to use “ $\mathbf{M}^{\text{top}}\mathbf{L}$ ” in place of the “ $\mathbf{M}^{\infty}\mathbf{L}$ ”. <172>

## Chapter C4

**Ashby's Adaptive Brainlike Mechanisms — but with added Self-organization**

## SUMMARY OF CHAPTER

This chapter provides a summary and discussion of Ashby's successive brain-simulation models, of increasing sophistication:-

- (i) a simple non-learning but reactive system;
- (ii) an “ultra-stable” system, with an extra feedback loop to allow it to randomly alter its response strategy if it has not achieved its goal by a certain time; and
- (iii) the “accumulator of adaptations” whose “gating mechanism” allows it to store its earlier strategies — in case the original situations should re-occur. This latter development seems to provide a third feedback loop, and is somewhat suggestive of a recursive process.

However it seems possible to envisage *a more-complete ensemble of self-organizing procedures* for such systems — a capability which seems essential within the real biological world, and which is developed in further detail in the next chapter.

**C4.1 Evolutionary pressure toward self-organizing systems**

Biological systems would seem to have, as a vital distinguishing characteristic, the ability to “actively” counteract a moderate range of exogenous disturbance-or-attack on their integrity as physical entities. By definition, such an ability will have survival value, so it must be expected that Darwinian natural-selection will promote the evolution of increasingly sophisticated systems of this type.

Ashby's “homeostat” or “ultrastable system” (1960) is a promising paradigm for understanding such mechanisms, but his account still depends partly on “ready-made” components (as he himself points out in his Sections 17/10 and 17/11). Let us therefore work carefully through his standard cases, starting with the simplest, in an attempt to postulate an unaided sequence of development in plausible biological terms rather than using the short-cuts of a computer-programmer aided by his “god-like” insight.

**C4.2 The trivial cases of unstable and metastable systems**

In the extreme case of an arbitrarily assigned set of entities with no coherence at all, then the set scarcely even qualifies for <174> the title of “system”. If disintegration does go on without interruption but is somewhat delayed by a modicum of cohesion, then we may talk of an *unstable* system; while temporary freedom from disintegration, pending some set of triggering stimuli, will characterize the *metastable* system.

In all these cases, the ensemble is likely to go into irreversible liquidation if left on its own without outside maintenance, so their interest to the biologist will be somewhat limited. Nevertheless two points should be made about them:- Firstly they may be viewed as a first easy rung up the evolutionary ladder; and secondly these concepts may be useful for describing *subsystems* which form part of a larger system capable of providing the necessary maintenance or restoration — especially if it can aid its own overall stability in some way by so doing.

**C4.3 Inanimate stability and stereotyped “responses” to “stimuli”**

Any isolated (or “*closed*”) ensemble will eventually end up in a stable static state, or in a regularly recurring cycle (Ashby, 1956/1964) — except in the freak borderline case of “neutral equilibrium” in which all feasible alternative configurations have the same energy state. But meanwhile, even for non-isolated (or “*open*”) sub-ensembles, there will also often be a spontaneous formation of locally stable subsystems — coagulations within the erstwhile

homogeneous or randomized substrate. Crystals or droplets will tend to form and disrupt the homogeneity of the medium — though this will depend on the overall conditions within the system: temperature, pressure, and relative concentrations, (Goel *et al.*, 1970; Goel and Leith, 1970).

The important point here is that these subsystems *do not need to be designed*; they will occur spontaneously given certain commonplace conditions, and they will tend to survive moderate fluctuations of <175> the environmental conditions also, without any deliberate maintenance from outside. Any would-be creator does perhaps need to design a suitable *substrate* (unless such a substrate is fortuitously provided, ready made), but after that he may just let things happen in their own way.

In its most basic form, such stability will manifest itself in ways similar to those described in the equilibrium-paradigms of elementary physics: a temporary displacement will fail to upset the system permanently, and it will return to its equilibrium state spontaneously. (In the present context of naturally occurring systems, it would be better to look at distortions to the shape of dew-drops or the energy-state of an atom — rather than the usually cited examples of pendulum or cube-on-a-level-surface; but the stability principle is essentially the same). The essential point is that such systems will react to specific “stimuli” by giving a specific response — perhaps allowing for statistical variation if necessary; they thus correspond to Ashby’s (1960) non-learning but reacting systems, depicted in Figure C4.3/1. <176>

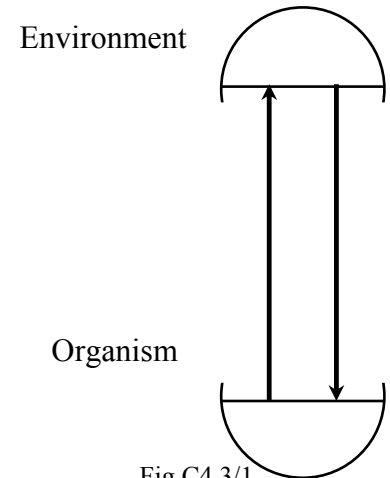

Fig C4.3/1  
Ashby’s Fig 7/2/1 depicting  
a reacting but non-learning system.

One point which does not seem to have been made clear in Ashby’s treatment until six chapters later, is that the “response” will not necessarily appear straight away, nor will it necessarily emanate from the stimulated part of the system; nor indeed will it necessarily show any preconceived temporal or spatial *distribution* — given that the system itself will be somewhat extended, and so capable of a multi-faceted response. a system (such as an atom) *may* simply fend off the stimulus (as when an atom causes an incident alpha-particle to “bounce off”), but it may alternatively bide its time (before re-emitting the same particle — or some other, if we choose to accept that it will still be the “same” system afterwards); and of course the disturbance may travel through the “body” of the system and eventually produce one-or-more responses at remote parts of the system. In short then, the “stimulus-signal” is likely to be subject to spatial and temporal *dispersion* (Ashby, 1960, Section 13/14 *ff*) whenever the system is polystable in Ashby’s sense (Section 13/2) of its having richly intercommunicating parts with many equilibrium positions.

If the system has a more meagre claim to polystability, by having a definite-but-more-limited intercommunication path and a more modest repertoire of equilibrium positions, then the effect may be less extreme — but it may be more useful and orderly. It may well be that this is one of the advantages which would favour the survival of *linear* molecules such as RNA if they were to be generated spontaneously. Anyhow, a mechanism of this sort has been suggested, in a more biological context, as a basis for the reproducible precise gross behaviour of animals, (Traill, 1976e).

#### C4.4 Systems able to switch to alternative response patterns

Unlike Ashby (1960, Section 7/20 *ff*), let us confine ourselves for the moment to systems which might reasonably be expected to form <177> spontaneously within a realistic evolutionary

time-scale — and using only elementary trial-and-error techniques. Orderly limited-dispersion molecules (such as RNA) would appear to answer this description and also serve as a suitable medium for the initial development of the adaptable-response mechanisms which we are about to discuss. In general we will be talking about collective systems comprising ensembles of linear strips which maintain communication linkage between them, yet representing distinct formulae for action or response. It is not important at this stage to speculate seriously about whether they are *physically* connected or not, though it seems convenient to think of them as joined end-to-end in the nature of chromosomal strips — even if this is less likely from an evolutionary viewpoint.

There would seem to be two ways in which adaptability could be built into such collective systems. Firstly we might expect to find sites along individual strips which were capable of taking on several different functional states — as “reversible mutations”. In most cases these would doubtless be no more than on/off “switches”, determining whether that strip would be available for participation in any ongoing activity; and of course this is likely to be of vital importance, even if it is only a beginning. It is also possible that some such sites might serve as multi-purpose switches or gearsticks, with their functional role changing according to the “switch-position”; but it should be recognized that the chances of structural economy occurring spontaneously would be comparatively remote as if an object selected for its knife-like properties, from amongst randomly fabricated metal shapes, were to be *found* useful for its comb-like properties *as well*. Anyhow, to the extent that this type of mechanism is adequate, there would be little need for the strips to form into ensembles involving higher  $m^m$  levels. <178>

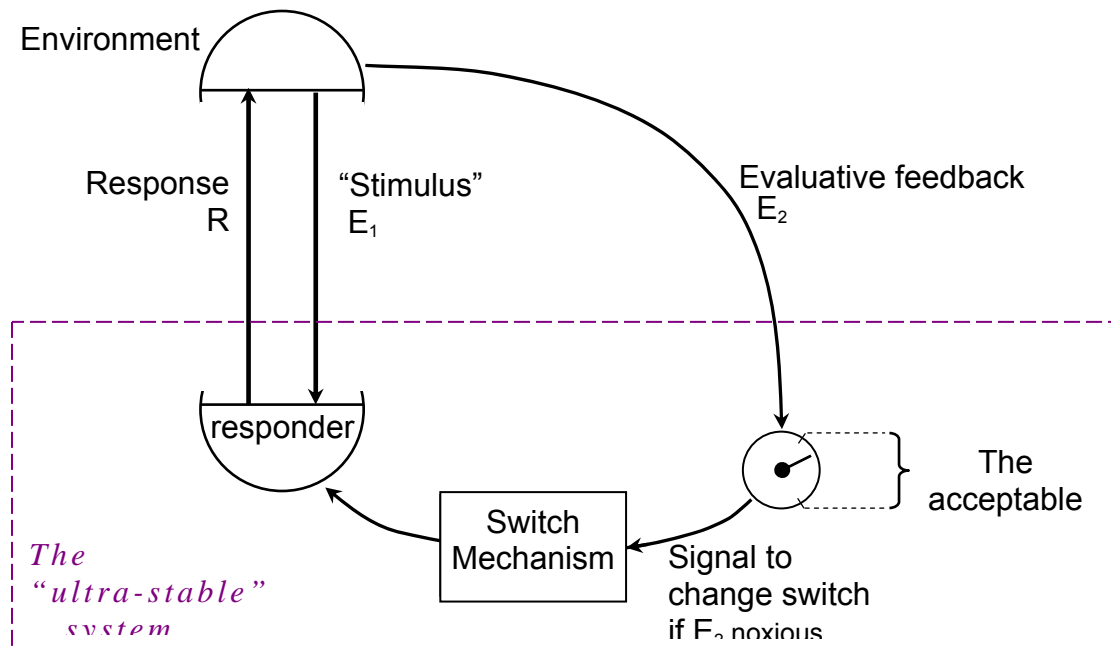

Fig C4.4/1. Ashby's concept of the “ultra-stable” system, capable of adapting its functioning response-pattern (usually reversible) according to changes in the environmental *pattern*. (Diagram adapted from Ashby's Fig 7/5/1, 1960).

<179>

The second source of adaptability would be the choice between whole alternative strips within the ensemble. The actual selection between these alternatives is likely to depend rather

critically on subtle nuances in the overall signal pattern, probably involving optical interference phenomena (Chapter B2, above; and Section C8.1, below). Such context-dependent mechanisms are of course thought to operate within the genetic code: if the developmental stage is right (so that it is emitting an appropriate pattern of signals) *and* if the cell is appropriately placed within the signal-pattern, then the cell's DNA will have its "liver-cell-development" strips switched on — or whatever is appropriate, if anything.

We may now turn to Ashby's "ultra-stable" system, and look at it in the light of the above considerations. To start with, we should notice that there is a degree of complexity creeping into the system which is now arguably beyond what we can expect to be created spontaneously with any sort of reasonable frequency; Fig C4.4/1. <179> Accordingly we should expect that some sort of self-replication mechanism would need to be one of the "actions" to evolve in the repertoire of such systems, at about this stage of development though perhaps slightly later. This would make it possible to store partial successes in the learning of survival-technique, in the manner of Ashby's cases 2 and 3 (1960, Section 11/5), already described in the present work (Section C1.2). Anyhow, such replication (together with mutation) would help to explain the postulated existence of *ensembles* of limited-dispersion molecules within a totally indifferent or hostile environment which contributes no guidance for the creation of the system — other than a stiff dose of fortuitous reality.

There would seem to be no great problem in postulating an RNA-like basis for such ultra-stable systems; see Fig C4.4/2. <Fig.C4.4/2> <180>

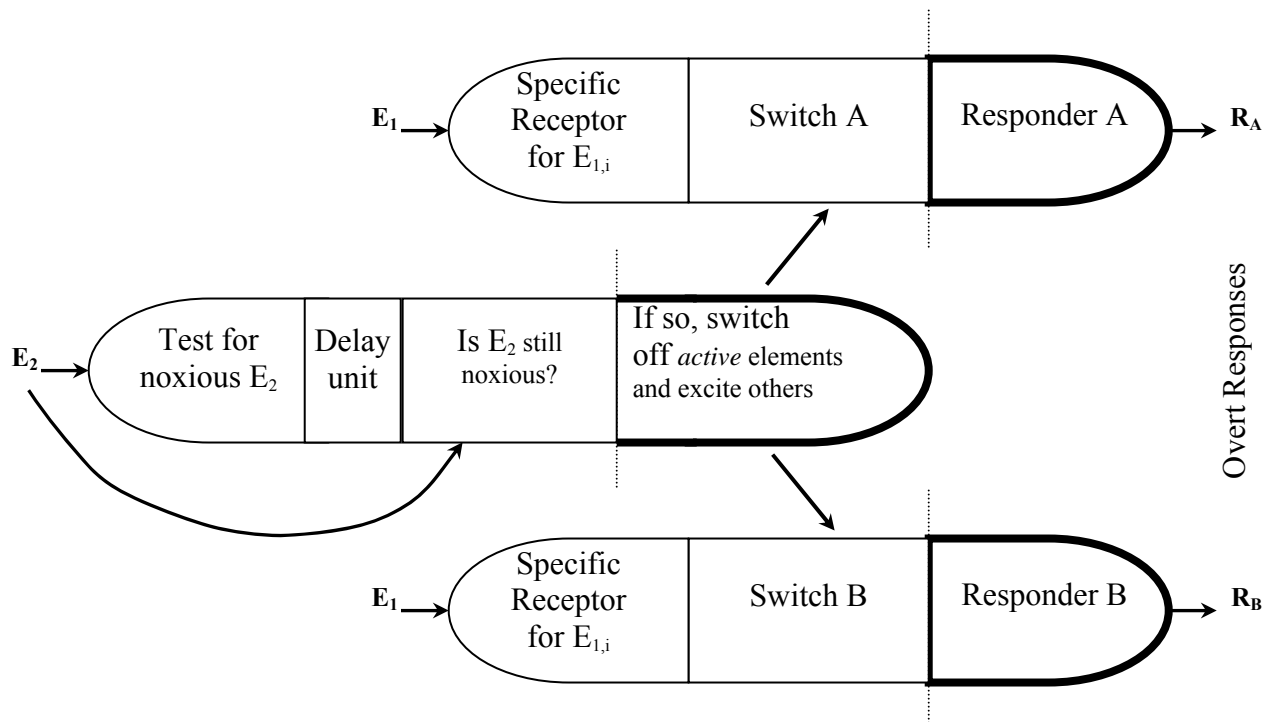

Fig C4.4/2. Schematic diagram to suggest a plausible ensemble of linear elements capable of functioning collectively as an "ultra-stable" system (as in Fig C4.4/1). Three types of linear element are shown here (and in practice each of these is likely to represent a whole population of coordinated similar elements). Those on the right correspond to the primitive paradigm discussed in Chapter B2 (above), but with switching-gates as part of their labels. The other element is also formally similar, but serves to re-set the switches; and this will occur in accordance with the pattern in a different category of inputs — the "evaluative stimuli"  $E_2$ . The "program" part of each element is heavily outlined, while the other parts, to the left, constitute the "labels".



#### C4.5 Purposeful switching to alternative response patterns

181

The system depicted above in Figures C4.4/1 and C4.4/2 operated on the principle of “let’s do *anything* in an attempt to alleviate the present discomfort” — much as you or I might do in a *panic* situation where our existing knowledge-and-experience seemed to be invalid. But given some sort of patently appropriate body of knowledge such as we could normally expect for human subjects, we would expect something more systematic than a mere random change of parameter-settings. As Ashby puts it, at the end of his Section 10/2 (1960): “If the reader feels the ultrastable systems as described so far, to be extremely low in efficiency, this is because it is as yet quite unspecialized; and the reader is evidently unconsciously pitting it against a set of environments that he has restricted in some way not yet stated explicitly ...”. Note that if the environment *is* totally capricious, unpredictable and unconstrained, then one might just as well go right on and panic — as in Figures C4.4/1 and C4.4/2 — there being no basis for anything more logical! Indeed there would not even be any basis for deciding what was a “suitable delay” before trying some other panic measure. Nor, come to that, would our genetic repertoire of panic measures (fight, flight, freeze, etc ) necessarily help at all! The very fact that such repertoires *are* fairly standard, reflects some degree of consistency in the “laws of nature” in the environment; and it also reflects the ability of surviving species to acquire a genetic “knowledge” about general approaches to coping with such situations in practice.

One important constraint commonly found in natural environments, is the tendency for events to present themselves in consistent patterns: “the recurrent situation” (Ashby, 1960, Sections 10/4 to 10/7). In these circumstances there is some point in acquiring the ability to transcend mere random panic reactions to noxious stimulus <181> E<sub>2</sub>, so that now it becomes sensible to respond systematically with a *specific* “switching” action — corresponding to whatever has been successful in the past. In Fig C4.4/2 there are only two alternative courses of action indicated, so it represents the trivial case in which there can be no choice once one sets out to change the switch-setting. But in general there will be many possible actions which one might take if “Switch A” is currently on and due to be changed; and one can imagine that initially there will be many linear codings for all the different competing actions which might be taken to try to escape from this situation. It then becomes easy to see that we will get the right sort of adaptive learning process if we postulate a Darwinian selection of the “fittest” amongst these coded linear elements; and moreover the explanation will then be fundamentally similar for both learning within the brain of an individual animal *and* for phylogenetic learning of hereditary traits within the species. (Cf. Chapters A2 and C1, above).

182

Another constraint likely to be found in the environment is the distribution of times for such patterns of stimuli-and-consequences to manifest themselves. If we imagine that the initial set of codings also varied as to the number of “delay elements” along their length (or some other equivalent “clock” mechanism), then we can see a way in which the organism-or-species might learn some “idea” of how long it should persevere with one line of endeavour before abandoning it as unpromising; (cf. Ashby, 1960, Section 17/10). Once again the process may be interpreted as Darwinian.

However such constraints are not so straightforward as would first appear. Such recurrent situations will often not recur immediately, and in the mean time other unrelated situations will frequently intervene. Thus the constraints in the environment will not usually present themselves as one ever-repeating pattern of events, <182> with all the essential elements discernibly similar; they will instead appear as a *variety* of *sub*-environments with such properties. So the constraints will be there alright, but if the organism is to take advantage of these constraints then it must be capable of adapting to the prevailing sub-environments. This means, firstly, that it must be capable of *storing* enough of what it has learned so that it can turn back to it later on — without having it “over-written” by any unrelated learning which has occurred in the interim. Such is the

183

problem considered by Ashby in the remainder of his Chapter 10 (1960) under the sub-heading of “the accumulator of adaptations”, and he depicts the solution as shown here in Fig C4.5/1. The various sub-environments are represented as  $P_1$ ,  $P_2$ , and  $P_3$ , while the corresponding alternative sets of storable response-determined experience are represented by  $S_1$ ,  $S_2$ , and  $S_3$ . <183>

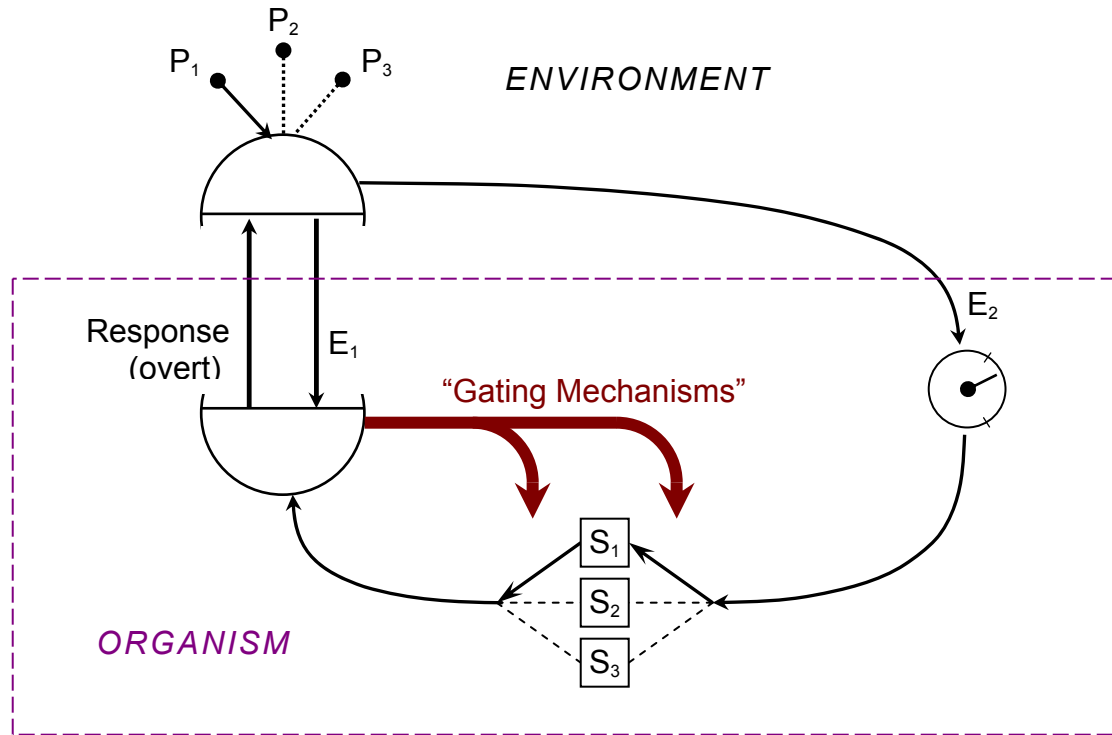

Fig C4.5/1. The “accumulator of adaptations” to various different “sub-environments” ( $P_1$ ,  $P_2$ ,  $P_3$ ), as depicted in Ashby’s Figure 10/9/1, (1960). <183>

Ashby’s account gives rather scant attention to the nature of the “gating mechanism” which selects which  $S_i$  should be used by the organism; nor does he elaborate greatly when he returns to the topic in Chapter 16. However it seems that we can make the system rather more mechanically plausible, without violating Ashby’s conceptualization, by re-drawing the diagram as in Figure C4.5/2. <Fig.C4.5/2> Here the gating mechanism is depicted as operating under the influence of a *third* sub-set of the general input from the environment,  $E_3$ , (instead of Ashby’s arrangement — which arguably amounts to the same thing — of using “a part of”  $E_1$ ). When seen in this way, it becomes easier <184> to envisage the mechanism as being a “higher level” recapitulation of the same basic linear micro-element mechanism postulated in Fig C4.4/1 and discussed further in the next chapter (Chapter C5). It also suggests the possibility of further recursion into even “higher” levels provided further distinctions ( $E_4$ ,  $E_5$ , ... etc.) can be made between different aspects of the input. This question also incidentally highlights the problem of just how these subdivisions of the input are to be made — a point which we will take up in Chapter C6.<185>

184

185

<Fig.C4.5/2>..<184>..

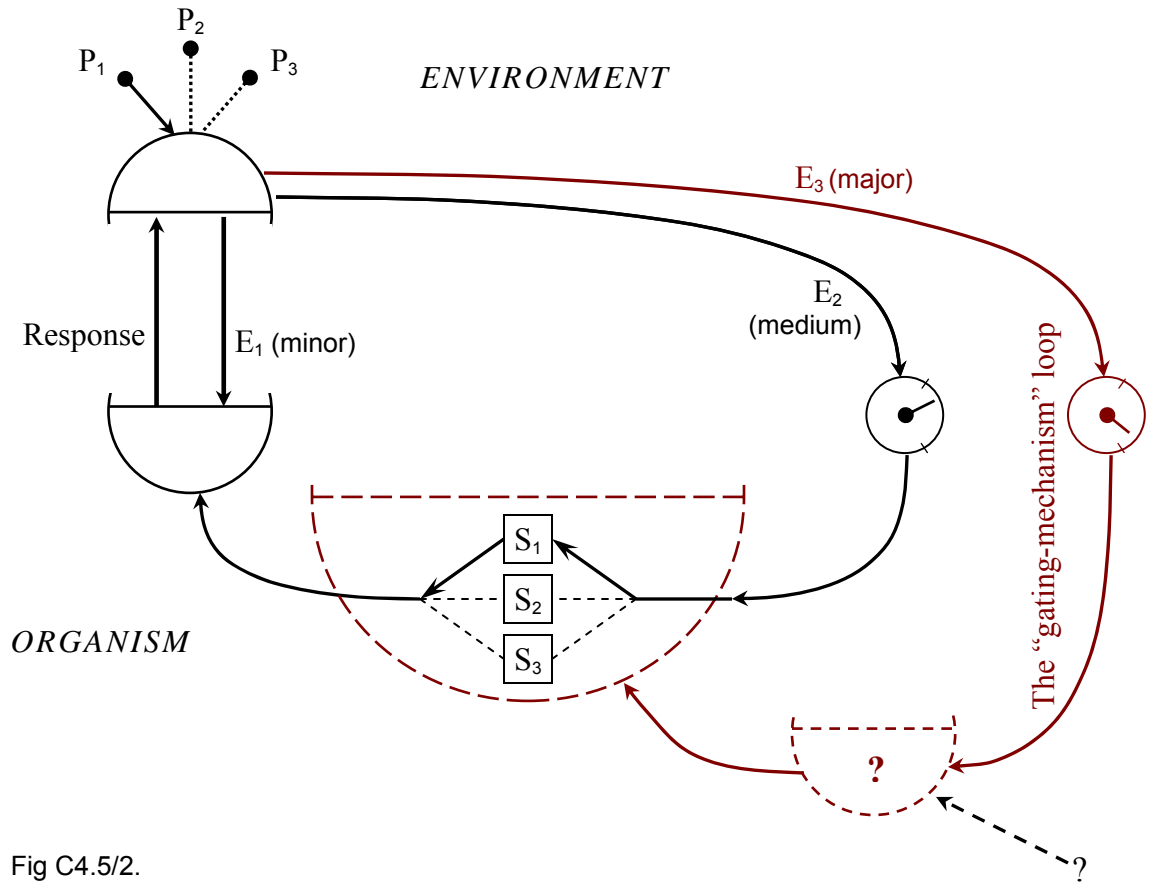

Fig C4.5/2.

A variation of the diagram of Fig C4.5/1 to emphasize the potentially recursive implications of Ashby's "gating mechanism", and to suggest approaches to explaining its operation. When there is a mismatch between P and S, then the S will be altered (randomly or purposefully) by the gating-mechanism loop. However this concept is developed further, starting at Section C5.1(3), so we should regard this  $E_3$  loop as provisional only.

## Chapter C5

**Toward Fully Self-Organizing Versions of Ashby's Systems,  
Using Populations of 'Linear Micro-Elements'**

## SUMMARY OF CHAPTER

This chapter sets out to reconcile Ashby's model with the molecular or 'linear micro-element' theory of memory which has been our main concern so far. In general this means introducing largish *populations* of structures capable of acting *collectively* in a manner similar to those outlined in Traill (1975b, 1976d). As it stands, Ashby's model is still too "computerish" and not biological enough (as he himself implies in his sections 17/10 and 17/11 when he lists five unexplained features as lacking provision for self-adjustment). The linear micro-element theory offers an explanation in essentially Darwinian terms, because the molecules (the presumed micro-elements) would be profuse enough for extensive trial-and-error procedures to work economically.

**C5.1 Some acknowledged defects in Ashby's exposition**

Like most working models, Ashby's model is presented ready-made with many of the important problems of existence already built into the system before "testing" begins. It is not easy to refrain from imposing one's observations of gross structure onto a model, and there are some advantages in taking such a short cut:- Displaying some limited-but-important principles (as here); Short term prediction; and/or Making-do when there is no guide to possible substructure. Indeed most model-builders (Dutton and Starbuck, 1971) impose even more structure onto their models — these being mathematical stereotypes which are then fitted, as best they can, by measuring the "relevant parameters" and inserting them into the model. In such cases the basic structure of the model itself is not regarded as being subject to continuing amendment (let alone evolution), though it may be seen as being "on trial" in an absolute pass/fail sense.

However it would seem that, for biological systems, their very structure must be largely self-constructed — with no explicit <186> guidance, though with some implicit shaping from an indifferent or hostile environment. (One might quibble on the detail of this proposition — after all education is explicit guidance in some sense, or so it would seem — but self-organization nevertheless seems to be the more important factor, especially embryological development of physiological structure which presumably lays the basis for feedback-loops like those in Ashby's diagrams. In any case, one can probably answer the "education" argument insofar as it is applicable — by regarding education as communication within the species, and asserting that it is this wider system which is self-constructing in the long run — even if this is not quite true for individual members of the species).

***Ashby's first two self-criticisms — problems potentially solved in the above discussion***

Ashby is more-than-usually aware of the desirability of incorporating such self-organizing principles into models which purport to depict biological reality. Indeed he himself lists five ways in which his model falls short of this total objective (1960, Sections 17/10 and 17/11):- (1) The duration of a trial, before abandoning it as "a failure", was set *by him* in the light of experience — and not by the system itself. However it has been suggested above (Section C4.5, paragraph 3) that it *is* feasible for systems of this broad type to adjust such timing-parameters, at least in the case of a 'linear micro-element population' realization of Ashby's general concept.

(2) Ashby decided for the systems: *which ranges* of the "essential variables" ( $E_2$ ) were to be considered "*good*" thus entailing a non-action "response", and which were to be considered "*bad*" so that they lead to attempts to change the input by altering the configuration in its own parameters. To simply identify such mechanisms with biological pleasure/pain activation is an

appropriate start, but it still leaves the problem: “How did the body come to decide that a <187> burn should be ‘painful’, while replenishing a physiological deficiency should be ‘pleasurable’?”. Indeed the problem is heightened when one considers pathological cases in which this formula fails to hold. Of course at a relatively trivial level one can *learn* that *object A* is pleasurable or *object B* is painful. this is the familiar paradigm of classical conditioning which has been interpreted in terms of the linear micro-element model by invoking the concept of genetic “cross-overs” between segments of the linear-elements (Chapter A1; Traill, 1976b). Similarly one can learn the same sort of differential between one’s own actions; this being the case of “operant conditioning” which may be explained in the same general way (*ibid.*), in what amounts to a Darwinian explanation entailing the competition for survival amongst the linear elements. It is possible, for instance, that those producing “painful” consequences fail to acquire the tag (or switch setting) that would enable them to be replicated; or they might be tagged “for demolition”; or they might simply fail to become incorporated into a self-supporting “schema” of mutually intercommunicating elements as an “internal closure” systems (Chapter A3; Traill, 1976e). *However* it would seem that the *ultimate* sense of pleasure/pain, from which the above phenomena derive, must be arbitrarily inbuilt into individuals in the first place. When such settings help survival, the setting is likely to survive along with the individual and be transmitted genetically; whereas a “wrongly-connected” individual will probably not survive; — Darwin again.

188

#### *Ashby's third self-criticism — What generates the “gating mechanisms”?*

(3)<sup>36</sup> Ashby points out that he has not made any suggestion as to how the organism might acquire its *gating mechanism*, shown here in Figure C4.5/1. However, if we re-interpret this concept as a “metasystem” ( $E_3$  in Figure C4.5/2), making recursive use of the same <188> basic type of mechanism as in  $E_2$  and  $E_1$ , then it begins to look as though a plausible explanation for this aspect of the self-organization might be forthcoming.

189

Some details, of how such a system might work, have been given in Traill (1976d). But first we should re-examine Figure C4.4/2, the base level mechanism, and re-interpret the role of such a subsystem when acting “on a higher plane”. For the base-level case, the routine interactions with “the outside” are  $R$  (the set of responses) and  $E_1$  (the set of “non-evaluative” stimuli) — both implying contact with the environment *outside the organism itself*. Let us now consider *another* such system in which the  $E_1$  and  $R$  interact with a *different domain*. Instead of interacting with the outside environment, we shall suppose that this new system will interact with a “pseudo-external” domain consisting of the stable elements of the original *system*. (Thus it would become capable of interfering in the activity of the original base-level system — as a god-like “meta-system”). What form, then, should such interference take?

Figures C4.5/1 and C4.5/2 portray this “gating-mechanism” interference as controlling the activity of the switch-setters ( $S_1, S_2, S_3, \dots$ ) by some means which is not clearly specified, though it seems likely that it might involve changing the sensitivity of the environment-oriented system to the evaluation-signals ( $E_2$ ) — presumably by blocking off communication pathways on the left side of Figure C4.4/2. This could make sense in the light of Ashby’s discussion, in his Section 11/5, concerning the tremendous practical benefit to be gained from *holding onto partial solutions* while other unsolved parts of the problem are explored further. Thus if we had a large population of environment-oriented sub-systems of many different types — corresponding to many possible transactions with the environment — then it would be sensible to be able to exercise <189> some sort of control over the incoming “criticism” via  $E_2$ . Otherwise the criticism is likely to be received at inappropriate points, with destructive results.

190

<sup>36</sup> We will not get to items (4) and (5) until Section C5.5. <188>

### *Not-yet-resolved aspects of the problem which now require deeper investigation*

This still does not explain how the organism comes to know *which* base-level sub-systems *are* to be left open to the prevailing  $E_2$  from the environment. To some extent this will doubtless be trivially genetic or structural, and not readily open to modification. Thus emergency responses such as pain or visual reflexes will often have a private, genetically-determined pathway; and such an arrangement is not really open to orthodox re-education, though it may well be *overruled* or else functionally isolated in some way, in some cases. Rather more subtly, it has been suggested that such stability may be partly due to the closing of a communicational loop (or a “more complete” topological enclosure than a mere loop) — in the form, perhaps, of elements such as those on the right of Figure C4.4/2 giving off responses which included a component which could activate other members of the group; (see Chapter A3; and Traill, 1976e). Such groups were then envisaged as being capable of acting collectively as new complex elements on which higher systems of organization could be based. This is a point to which we will return shortly, early in the next section.

But leaving aside these more automatic cases, we are left with the previously-mentioned situation in which one “higher” subsystem interferes with the parameters of a “base-level” subsystem; (or more correctly, one parallel *set* interferes with a lower parallel set). How then does it “know” which type(s) of base-level subsystem it “should” interfere with, and in what direction? Indeed how does it “know” that it should interfere in anything, or take any action at all? The answer, according to this model, is that it generally *does not* know any of these things *a priori*; (or if it does, then the knowledge <190> was gained genetically — by orthodox natural selection amongst its ancestors). It is postulated instead that, as in the case of the base-level codings themselves, the higher subsystems develop from a large number of more-or-less arbitrarily coded elements which then have to compete against each other for survival under the prevailing conditions. It is rather less clear what form this evaluative feedback (higher-level  $E_2$ ) should take, but we may tentatively suppose that it is governed by essentially genetic-based mechanisms, as for the lower level. The main difficulty would seem to be how to distinguish adequately between various painful evaluative verdicts, where these are “appropriate” to only one of the two respective levels. How then could we tell which of these two levels should be amended for each of the various painful feedbacks? Once again this is likely to be ultimately explicable in terms of trial-and-error among competing units — genetic and/or learning elements. In particular, acceptable trial-times are likely to be very different for the two cases; (Ashby, 1960, Section 17/8; see also Sections 3/15 and 8/15).

The problem of distinguishing between different levels of evaluation will be discussed in Chapter C6. Other points relating to Ashby’s list will be continued in Section C5.5, after two longish digressions:-

### **C5.2 Exploring details of linear micro-element versions of such mechanisms**

It seems desirable, at this stage, to take the time to reconcile the picture presented in Figure C4.4/2 with that portrayed earlier (Chapter A3; and Traill, 1976e), in which the development of representations of sets and groups was explicitly emphasized. For both versions, the basic element is the “RNA-like linear microelement”, envisaged as being approximately as shown in Figure C5.2/1:- <191>

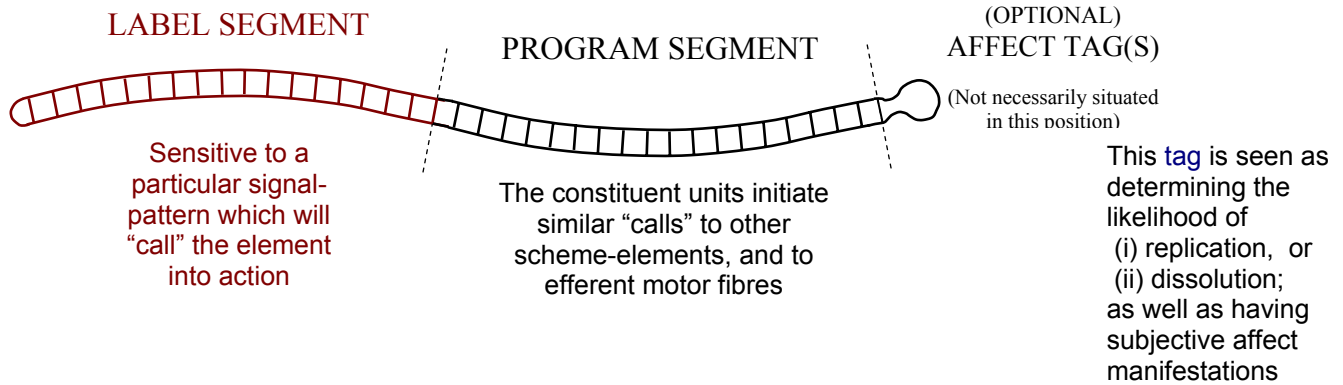
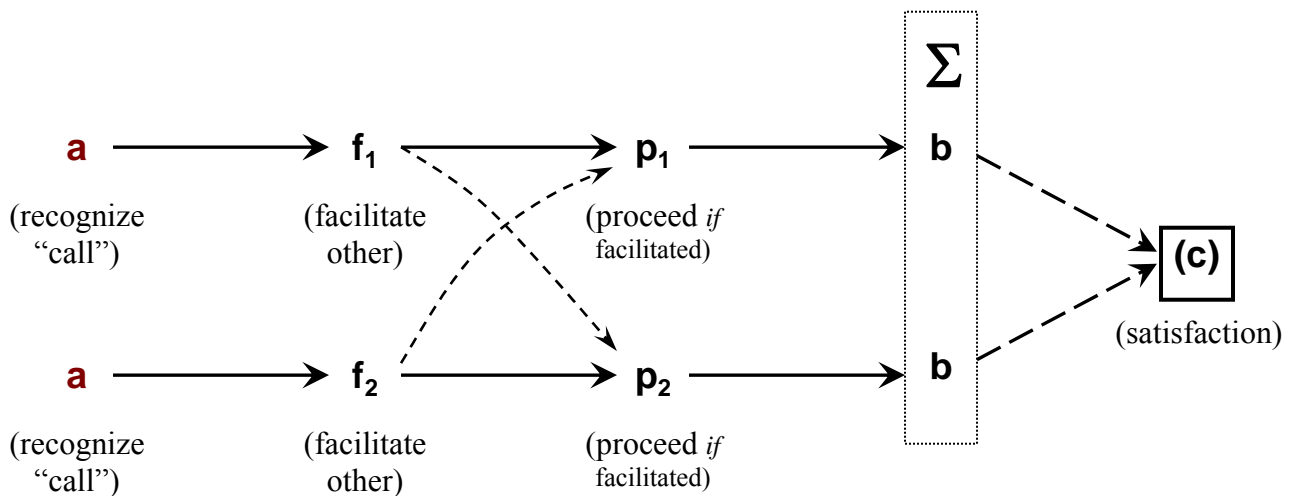

Fig C5.2/1. Supposed "anatomy" of an RNA-like linear micro-element (of the simple type, lacking any "AND-gates" within the program segment). This is offered as the physical counterpart of the functionally defined "scheme-element" (Part A, above). This diagram is taken from Traill (1975b), with slight modifications to accord with developments in Part B, above. <192>

It will be evident that the three sub-parts in Figure C4.4/2 conform to this general pattern — though with some doubt concerning the roles of "switches" and "affect tags". Also it is not immediately clear that these functional units in Figure C4.4/2 are actually envisaged as comprising physical *populations* of linear micro-elements (of a slightly more complex type involving synchronizing signals) as depicted in Figure C5.2/2.

192



(193)

Fig C5.2/2. Illustration of how the individually-insignificant micro-elements may collectively cooperate, under favourable circumstances, to produce significant behaviour. Only two elements are depicted here, but the concept should be thought of as applying to a somewhat larger number — probably involving a threshold concept, in that only when there is a sufficient active population with sufficient unanimity and synchronization, will the behaviour actually take place. The diagram is taken from Traill(1976d), but alternative versions may be found in Traill (1975b and 1976b), and in Section A3.4 (above). <193>

### Synchronization and specificity of elements

This question of cooperative activity amongst the postulated elements is arguably another situation for which categorization of elements into sets would turn out to be essential. It would seem to be invariably necessary to involve largish numbers of such elements, and often it would seem to be important to orchestrate various different types in one collective complex action; but clearly it will be crucial to be highly selective and orderly in the involvement of these various elements — in higher animals at least. If such specific selection is to take place, then there must <192> inevitably be some effective mechanism whereby the elements are allocated to *sets*: either by *intensive definition* (relying on shared common labels, tags, or other distinguishing features on the elements themselves); or by *extensive definition* (using externally imposed boundaries or other physical constraints on the physical elements); — or by using some combination of both methods.

193

For instance, in the straightforward case depicted in Figure C5.2/2, the two-or-more parallel elements would presumably both be called into action when they both “recognize” the same signal at about the same instant; here the possession of the correct “recognizer” or “label” serves as an intensive definition of the relevant set — and if the signal has only a restricted distribution confined to a local area, then there is also an extensively defined criterion to delimit the (sub)set which is to be activated. (Further details on this postulated process of recognition are given in Sections B2.3 <193> [above] and C6.7, and in Traill (1976b); but briefly, the label segment is seen as a series of sites receptive *individually* to specific pulse-or-wave configurations — *and* to the prior excitation of the previous site, if any; so that the *chain* of sites will only collectively accept signals with the “correct” temporally extended pattern, probably in the infra-red region of frequency components).

194

Another example is afforded by the postulated activity of “affect tags” (see Figure C5.2/1, above). Generally speaking, these are thought of as auxiliary labels which *intensively* define their respective elements as “good, bad, or indifferent”: thereby influencing the likelihood that these scheme-elements (or the schemes of which they are part) will be called into action. Alternatively or additionally they may also influence the chance that such elements will be annihilated as unwanted cellular rubbish. However we may also suppose that such tags will often be *context-dependent* in their significance. Thus if an animal is *angry*, or *fearful*, or *sexy*, then quite different sets of scheme-elements will be “switched on” or at least made more sensitive to the prevailing signal traffic, while other sets of elements will be inactivated for the time being. In this way then, it will be possible for the important and far-reaching sets of “good” and “bad” (or “appropriate” and “inappropriate”) to be *superimposed* reversibly, briefly, and flexibly, *right across* any other existing set-memberships of the elements — and without necessarily altering those other membership categories in any direct way. Such tag-activation would presumably be performed overall by endocrine hormones; or more selectively by means of the Autonomic Nervous System — implying a location-based *extensive* component to the definition for sets of elements in this case. [Indeed, broadly speaking, the transmitter-release from normal synaptic activity of the *Central Nervous System* might *also* be seen in this comparatively <194> lowly role, while the *detailed* information could all be coded within the postulated infra-red signals!]

195

### Stability of element-ensembles

Yet another instance of the usefulness of this conceptualization of sets has been the proposed explanation of the nature of Piaget’s schema, and how it comes to be formed; (Part A, above; Traill, 1975b, 1976d). To quote from Chapter A3:-

“*Schemata* were seen as scheme-like structures which had somehow acquired an inherent stability and were therefore virtually impervious to modification, unlike schemes. It was supposed that they owed this stability to some manifestation of corroboration (i.e. self-consistency ...) ...”.



One supposed mechanism producing stability of this sort was sketched, in outline, in the third-last paragraph of the previous section (Section C5.1). This concept brings together a number of ideas; notably the notion of “seeking out” of “*internal closure*”<sup>37</sup> as a collective property for related scheme-elements — and this is closely identifiable with the well-known concept of Gestalt (English and English, 1958). Essentially this entails building models which will tend to have a *mathematical group* type of structure; — a strategy which is likely to pay off because many phenomena in our environment do seem to have such a structure, especially for solid objects and discrete phenomena. [It may well be that we are less well equipped to deal with concepts involving continuity — at least until we devise some discrete way of symbolizing them. Thus Bridgman (1927) wrote “The mind seems essentially incapable of dealing with continuity except in negative terms.” (page 94); while Ashby (1960, Section 17/9) writes “But when the whole system is not so divisible it remains merely a fearfully complex whole, not capable of reduction, ...”.]

Other ideas inherent in the notion of group-structure modelling of this sort are concerned with the likely mechanics of such model-<195>building and maintenance. a useful guiding biological “intuition” for this is the principle that physiological structures tend to develop appropriately *by virtue of* the stress laid upon them.<sup>38</sup> In the present context this encourages the notion that the survival of individual scheme elements may be promoted if they happen to be part of a communicational network which is continually “exercising” its collective self by echoing lowish-intensity signals around its network. (Such activation might, for instance, ensure that the elements did not fall into a state of particularly low energy — perhaps centred at a particular site such as a “tag” — in which state it might be vulnerable to dissolution as “rubbish”).

196

### *The formation of meaningful ensembles*

Here we have been talking about the *maintenance* of group-structured schemata, but we need to go into the matter a little more deeply to explain their *formation*. In fact these structures are seen as being comparatively sophisticated types of schemata, so we should now give some attention to the rather more elementary structures which have the properties of sets (i.e. lists), defined *extensively* in their essentials, but which have not (yet) achieved group-status. (It is supposed that the group structures must, in fact, progress through this mere-set stage during their development. After all, to the mathematician, a group is simply a specialized <196> *type of set*).

197

The problem for the organism is to gather together, into some readily controllable centre, the access to those scheme-elements which are all characterized by some common property. Or, in other words, the task is to translate intensive definitions into extensive definitions — except perhaps for the trivial case in which the formal *label-segment* constitutes the intensive definition (in which case there is arguably no need for an extensive definition since the members are already “on tap”, as in the first example following Figure C5.2/2, above). Anyhow, this process of translation of other distinguishing features into physical structures representing extensive definitions is explained, as in Traill (1976d), using Darwinian and genetic concepts as follows:-

<sup>37</sup> Here “closure” is effectively synonymous with “coherence”, as discussed later in Traill (2005c) — [www.ondwelle.com/OSM03.pdf](http://www.ondwelle.com/OSM03.pdf) — and in philosophy-orientated works generally; [RRT 2006].

<sup>38</sup> There is an obvious advantage in such a biological strategy in that the animal is taught by *the environment which is actually present* rather than some out-dated formulation of what the environment should be; and moreover it makes for tremendous savings in the amount of information needed to be transmitted genetically. Galbraith (1977) makes a similar point when he compares the regulation-bound Spanish colonial administration with the pragmatic approach of the British administration in India. And returning to biology, Ashby (1960, Sec. 18/4) writes: “it is *the mouse* which teaches the kitten the finer points of how to catch mice.” <196>

First we need to consider how *any* sort of arbitrary list could find physical representation in terms of the linear micro-element model. It scarcely seems likely that in such circumstances the elements should become physically enclosed within vesicles containing representatives of the set's members, but some functional-equivalent to this is required. Perhaps such elements could somehow become “moored” along a master linear element which would form a “spine”, like the side-chains along an aliphatic carbon-chain? Unfortunately it is difficult to see how such a structure could replicate effectively — unless the side-chains were quite short — and replication is probably an essential means for “amplifying” successful combinations of this sort. In any case, if the listed elements were of any appreciable length (and some of them might well be), then it would be wise to do what sophisticated computer “sort” programs do: *i.e.* deal only with the “names” (label codings) of such elements — not the elements themselves, as these can be accessed subsequently by using the label-coding if necessary. <197>

Thus we may start by thinking of the list as a master linear element, with its own separate label segment “ $\alpha$ ”, followed by a series of names ( $\beta_1, \beta_2, \beta_3$ , etc.); and this is the arrangement as portrayed in Traill (1976d). However there is a possible difficulty with this too *if* we are thinking in terms of adding and removing names from the list, because it is hard to see how this could be done without breaking the chain. For the moment then we will have to contemplate a compromise, which seems to mean short side-chains (for the names only) short enough to be encompassed in the replication process *as* side chains, *or else* able to undergo a conformational change such that they “slip into line” for replication purposes. Of course if we are prepared to accept these master elements as having a substantially fixed membership once they are formed, on a Darwinian trial-and-error basis, then the name-codings can be considered to be entirely linearly arranged without any need for side-chains at all.

Next we should consider how such sets come to have relevant and helpful entries in their name-lists. According to Traill (1976d) there is “an arbitrarily set expectation (intensive definition) as to what the membership criterion should be for the particular list; (embodied, perhaps, in the properties of the first member?)”. Candidates are then tentatively accepted (or perhaps merely considered) pending acceptance or rejection on the basis of the arbitrary criterion; while the survival of the list itself, as a whole, depends on the relevance of the arbitrary criterion to the apparent needs of the organism. (Such possibilities are re-evaluated below in Section C8.1(a), but the above account will serve for the present discussion).

Several practical problems arise out of this suggestion, and they will need a more thorough investigation in the hope of finding a more rigorous yet plausible mechanistic explanation. The first <198> problem is how the arbitrary “membership criterion” is to be encoded; and this leads into the second problem of how candidate members are to be selected on such a basis. Another associated question is to consider what communicational and spatial connections there might be between the “list-of-symbols” on the one hand — and the actual items represented by those symbols, on the other hand.

It was suggested in the earlier work (Traill, 1976d), that possibly the first-named item on the list might also serve as the paradigm criterion by which all subsequent candidate members might be judged. At first sight it is difficult to see how this could conveniently be executed if the list contained only a “name” for the paradigm concerned; it would seem to be too cumbersome to be constantly invoking this name to access fully-fledged exemplars at relatively remote sites whenever a new candidate member was being assessed. Rather it would seem probable that any such criterion would need to be physically attached to the list — in full relevant detail, and not by “name”; (though it is possible that such attachment could be intermittent and reversible — depending on how the list was being used or replicated at that time, and this would possibly be related to the various sleep modes).

Figure C5.2/3 sketches the general idea of how a “higher order” linear element might constitute a list; but it gives no clear answer to the problem of criterion-specification, so we should now attempt to remedy this deficiency.

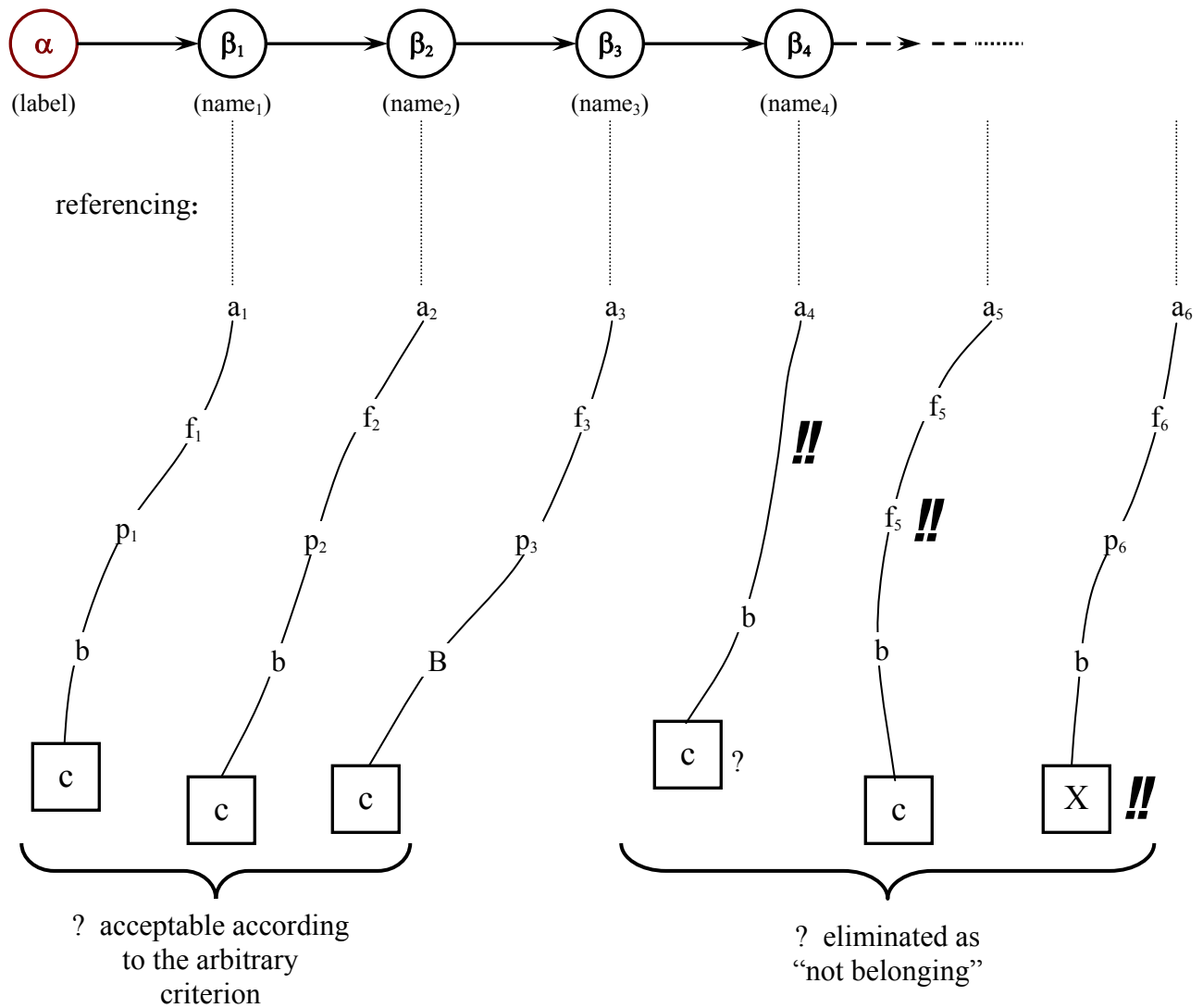

(200)

Fig C5.2/3.

<200>

Slightly modified version of a diagram from Traill (1976d) depicting the postulated “higher level” linear element ( $\alpha$ - $\beta_1$ - $\beta_2$ -...) serving to construct, physically, an extensively defined set or list. This set is shown as consisting, momentarily, of six linear elements. Three of the element-names ( $\beta_4$ ,  $\beta_5$ , and  $\beta_6$ ) “should not be there” because the codings of their corresponding elements do not accord with the arbitrarily preset intensively defined criterion for the set, so these member-names are seen as about-to-be-ejected. The detail of this arrangement is criticized in the text, and a subset of simpler structures proposed instead.

*Practical procedures for establishing ensemble-“lists” — each with its consistent criterion*

Suppose then, that such a criterion segment ( $\gamma$ ) were to be fitted somewhere into the higher-level linear element in Figure C5.2/3. How then could this effectively influence the membership of the (extensive) list? For the moment we may also suppose that such an *element* will contain *only one* member-name,  $\beta_1$ , (any other names being held by other similar elements in a population all having <199> the same label,  $\alpha$ ). Thus, if  $\alpha$  is activated, the  $\beta_1$  will also be activated in turn, sending off a “call” to labels of the type  $a_1$ . As a consequence of this, at least some of the “base-level” elements will be activated — either with overt behaviour, or perhaps asynchronously or subliminally so that there is no overt effect. Anyhow, it may be supposed that such activation will produce some sort of reproducible and locally-recognisable signal activity capable of being monitored at the “criterion” segment ( $\gamma$ ) of the “higher level” element, enabling this element to be tagged according to whether or not it is consistent between its *intensive* component ( $\gamma$ ), <200> and its *extensive* component ( $\beta_1 \rightarrow a_1 \dots$ , etc.) which provides the *feedback* on which the comparison can be made with  $\gamma$ ; see Figure C5.2/4. [ <201>]

200

201

Special (sleep)-modes of operation might be involved here in several ways. In particular, the suppression of overt behaviour is one likely result. Also the monitoring and tagging procedures might well be impossible during the normal “noisy” activity of the awake state, so this might supply the reason for any such suppression.

In the version of the theory just described, in which each “higher element” of the set held only one name ( $\beta_i$ ), our extensive <201> definitions have lost the *ordering* of the names in that list — as compared with Figure C5.2/3 where they are clearly ordered. So does this matter? In fact this loss will arguably make our model more realistic in several ways:- To start with, it is more credible to imagine the spontaneous mutation of linear elements into usable re-codings of the type  $\alpha\text{-}\beta\text{-}\gamma$ , rather than the more unlikely longer sequences of the type  $\alpha\text{-}\beta_1\text{-}\beta_2\text{-}\beta_3\text{-}\dots\text{-}\gamma$ . Secondly, we arguably do not usually start our concepts of sets-of-objects by thinking of them in terms of ordering; and indeed such *ordering* concepts take some degree of experiential sophistication before they develop, (Inhelder and Piaget, 1964, Chapter 9, p 247). Mind you, this might be explained as an initial random ordering of the  $\beta_i$  units among the different elements making up the relevant higher-order *population* of elements ( $\alpha \dots \beta_i \dots \gamma$ ), though one might expect a speedy selection process in such circumstances.

202

Then obviously, it is difficult to see how the “ $\gamma$ ” could effectively monitor the *simultaneous synchronized* feedback from all the  $\beta_i \dots a_i$  connections within the set; whereas with a separate physical label ( $\alpha$ ) for each  $\beta_i$ , there is at least a chance of moderately-asynchronous-but-adequate feedback — especially if other activity is reduced by using a “sleep” mode. Finally if the  $\beta_i$ s were to be added and subtracted as implied in Figure C5.2/3, then there are further difficulties such as how to stop the whole physical sequence from breaking inappropriately and losing the  $\gamma$  segment, along with the distal  $\beta_i$ s. (This assumes that the  $\gamma$  is at the far end away from the  $\alpha$  — as it probably *would* be in view of its *post hoc* role and the supposed transmission of the internal signal along the element away from the  $\alpha$ ).

Note that these considerations do not conclusively rule out the possibility of two or more  $\beta_i$ s in series, as depicted in Figure C5.2/3. It is conceivable that the membership criterion codings might be located remotely in a detached  $\beta_1$ , either initially or as a later sophistication, and that other linearly-ordered members might then be added; though it remains to be explained how the detailed operation of such a system could take place, and until then we should regard it as suspect. (One of the attractions of such an arrangement would be the ready explanation it would offer for temporally-ordered sequences of behaviour *if* these are deemed to be important at this

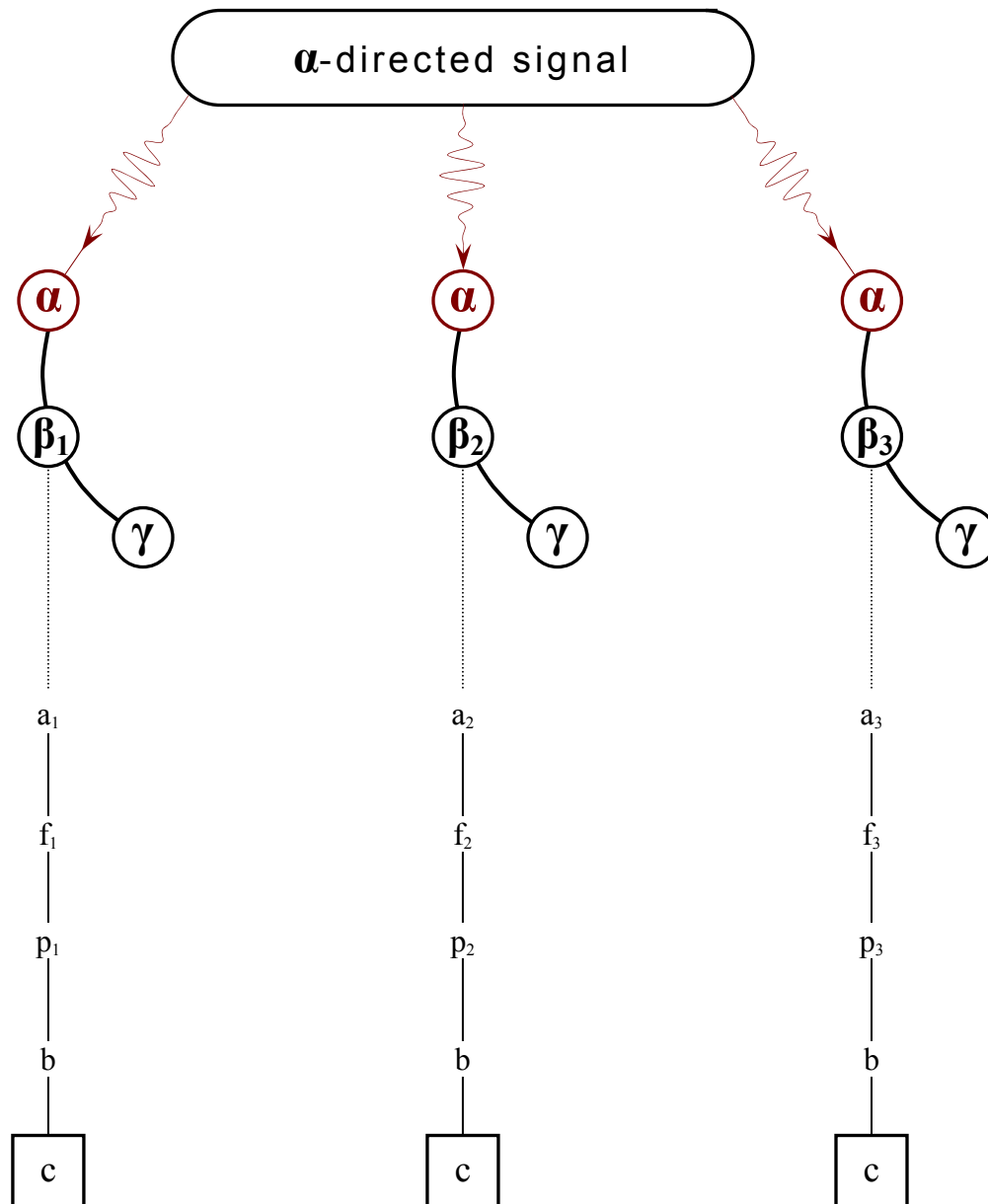

(201)

Fig C5.2/4. A variation on the theme of Figure C5.2/3. Here each  $\beta_i$  is held by a separate “master” element which nevertheless acts in unusually close cooperation with its fellows; — a well-controlled intensive linkage (rather than a genuine “tethered extension”). Only one subsidiary element ( $a_i - f_i - \dots$ ) is shown for each  $\beta_i$ , though in general there would probably be many available and the reference would presumably not distinguish between those with the same “i” value. <Fig.C5.2/4> <201>

higher level. But even if they *are* important, they could be explained alternatively in terms of differential time delays or by chain-reactions between such elements, or by parallel lower-level linear-elements — though admittedly such explanations would themselves seem to be rather cumbersome). However, until we are pressed to look again at such possibilities by unexplained inconsistencies, it would seem best to opt provisionally for the simpler *basic* mechanism outlined in the previous four paragraphs — on the “Occam’s razor” principle.

(Actually neither of these two proposed techniques seems to be entirely satisfactory if it is to be *the* method of organizing sets. Accordingly we will later be looking at yet another suggested technique, which will be depicted in Figure C8.1/4, below; and there may well be other possible arrangements of a similar nature. Moreover it is quite conceivable that some or all of these alternative methods might be used concurrently as a collective pluralistic system).

#### *A likely topic-segregation role for cell-membranes (and other brain subdivisions)*

Extensive definition can, and does, take another form; (arguably co-existing with the one we have just discussed, and quite possibly also *collaborating* with it). An extensive definition of a set is most commonly seen as the *drawing of a physical boundary* around the relevant members, thus isolating them from non-members; so what could be more natural than enclosing supposedly similar molecular members <203> within a restricting cell-membrane. For much of the brain (other than the “association areas”) there is ample evidence that function is localized in a systematic way (e.g. Hubel and Wiesel, 1962; Thompson, 1967, Chapter 11); but it has not been clear in detail just how such specialized cells operate, and it has been even less clear how they come to be in such methodical positions with such systematic functions. Of these, the question of operation might be explicable if we invoke the above molecular theories; and the question of construction clearly raises problems of embryology and development. It is quite possible, however, that such molecular theories are applicable to embryology, and that embryological considerations are pertinent to theories of molecular encoding; so it might well be profitable to be on the look-out for unifying principles here.

204

### **C5.3 Embryological considerations, and their relation to the extensive definition of linear micro-element sets**

This is not the place to embark on a full discussion of the likely mechanisms of embryological development; but it does seem appropriate to sketch in certain ideas which would seem to have some immediate bearing on our present problem. Trinkaus (1969) explains, with some understandable misgivings, the commonly accepted notion of how the cells of a developing organism may be guided into position by the supposed process of *chemotaxis* — extreme sensitivity to gradients of chemical concentration, which are presumed to be somehow set up and maintained in just the right way at the right time in a reasonably robust way. I have yet to see a reasonably detailed working through of just how such a mechanism might operate; but, in any case, it has seemed to me for some time that a much more likely explanation might be found in terms of one of the war-time navigational aids — code-named “Gee”, (Crowther and Whiddington, 1947, pp 53-56). <204>

This system (“invented by Mr. R. J. Dippy and developed by his team at Tele-communications Research Establishment”)<sup>39</sup> involves the emission of a signal from one centre *A*, which then stimulates the emission of secondary signals from two other “slave” centres *B* and *C*. Provided that the time taken for each path remains consistent, and provided that a suitable periodicity is maintained by *A*, then the pattern of crossing secondary signals forms a grid network on which meaningful navigational moves can be made. One could, for instance, follow

205

<sup>39</sup> and eventually developed into our present-day Global Positioning System (“GPS”) — [RRT 2006]

one set of wave fronts with axons from one set of neurons, and the other wave fronts with other neurons — thus forming such extraordinary structures as the optic chiasma, whose criss-crossed architecture is so baffling to explain in terms of chemotaxis. In “Gee”, the network lines were hyperbolic; but it is not too difficult to envisage the formation of other shapes by using larger numbers of slave centres — possibly using distinguishable call-signs, and possibly *partly* depending on chemotaxis or other influences. (Come to think of it, there is a formal similarity between such ideas and the notions of Huygens — developed later by Young and by Fresnel; (Bell, 1947; Jenkins and White, 1950)).

Moreover, in view of the circumstantial evidence from other theoretical fields<sup>40</sup> that infra-red local radiation is likely to be an important biological phenomenon; it would seem that there are now reasonable grounds for taking seriously the idea that the “Gee” principle might be crucial for embryological and developmental processes<sup>41</sup>.

An interesting set of cases is provided by the work on regeneration of the optic nerve in amphibians (Sperry, 1943; Sperry and Hibberd, 1968). It is difficult to see how the cut optic fibres could re-connect more-or-less as they had been originally — <205> despite physical obstruction or *rotation* of the target optic-stump unless some system of call-signs (intensive definitions) were in operation. The subsequent re-connection would then constitute a re-establishment of the equivalent *extensively defined* associations, thus emphasizing a particular form of informational redundancy and interchangeability, and therefore robustness in the face of perturbation.

Why then is there no regeneration for a cut mammalian optic nerve? Could it be that once the initial connections have been made, the call-sign system *changes role* from carrying hereditary information (which is now left to the extensive definitions inherent in the connections) and now takes on the task of encoding the results of learning processes? After all, Sperry’s amphibia were unable to learn to correct for the rotated eye, whereas human subjects *can* learn to correct for “mirror-vision” spectacles in a way reminiscent of Ashby’s homeostats. Such a role-change would also seem to be consistent with the observation that neurons cease dividing mitotically<sup>42</sup> at about the same time as they (presumably) become functional, suggesting that the genetic equipment (DNA etc.), having fulfilled its initial role in producing “extensive” structures, is now free to be used for a different type of intensively-defined coding — arguably the scheme-elements or “tapes” of the “Linear Micro-element Theory”.

In this light, it seems likely that any tendency to use “higher order” linear elements (to tether or list the basic elements) might constitute a new alternative method for forming extensive definitions which does happen to be *compatible with the newer non-genetic intensive codings*. We might well consider that this constitutes a first step up the hierarchical ladder (the “m<sup>1</sup>l” scale of

<sup>40</sup> Cope (1973) on ATP metabolism — and later references “45-51” cited in Traill (1988 — *Speculations in Sci. & Tech.*, 11(3), 173-181) on photon-emission from nerve-fibres. — Also see Part B, above, [ [www.wbabin.net/physics/trail18.pdf](http://www.wbabin.net/physics/trail18.pdf) or [www.ondwelle.com/MolecMemIR.pdf](http://www.ondwelle.com/MolecMemIR.pdf) ] concerning saltatory conduction *and* molecular spectra (*ibid.*, Table 2.2/I).

<sup>41</sup> — a view supported more recently by theory-and-evidence regarding the control of myelin-growth, (e.g. Traill, 2005a — [www.ondwelle.com/OSM01.pdf](http://www.ondwelle.com/OSM01.pdf) or at [www.wbabin.net/physics/trail4.pdf](http://www.wbabin.net/physics/trail4.pdf)).

<sup>42</sup> By now (2006), it is known that this adult mitosis-suppression is not always true, though the exceptions are fairly rare and specialized so the argument still seems supportable in general. See:

- Nottebohm, F. (2002 Feb 1) “Why are some neurons replaced in adult brain?” *J.Neuroscience*, 22(3), 624-628. <http://psych.colorado.edu/~munakata/csh/nottebohm.pdf>
- Gould, E., & C.G.Gross (2002 Feb 1) “Neurogenesis in adult mammals: Some progress and problems”. *J.Neuroscience*, 22(3), 619-623. [www.jneurosci.org/cgi/content/full/22/3/619](http://www.jneurosci.org/cgi/content/full/22/3/619) —
- Traill (2005b, sec.(15)): [www.ondwelle.com/OSM02.pdf](http://www.ondwelle.com/OSM02.pdf) or [www.wbabin.net/physics/trail2.pdf](http://www.wbabin.net/physics/trail2.pdf)

Chapter C2, above), with some formal similarities between the two <206> levels, but using discernibly different mechanisms. If so, then clearly any recursive process we may envisage will not be a totally “pure” one; (see Chapter C3, above).

#### C5.4 Concept-structure types within each level: another digression in preparation for clarifying Ashby’s difficulties

When we digressed at the start of Section C5.2, we had just been in the middle of discussing the third item on Ashby’s list of unexplained features: namely, that he had offered no suggested process whereby his “gating mechanism” could be established without deliberate outside intervention.

His difficulty in giving a detailed account of better-than-random tinkering, by the system, with its own parameters may be partly ascribed to his emphasis on *actions* — neglecting consideration of more sophisticated symbolic representations of the real world outside. The main symbolic structures are likely to be: *verb-like* concepts which represent actions (but without executing them), and *noun-like* concepts representing objects (or mental schemata, in the case of abstractions without any tangible external embodiment).

“Verb” concepts may be taken to be made up of linear elements of the straightforward action-type, but with some sort of inhibitory switch which prevents them from actually initiating any action under normal circumstances. (“Abnormal” circumstances may be determined by hormonal, reticular, or Autonomic Nervous System influences — selectively setting such switches on, and plausibly leading to such phenomena as dreams, “acting out”, and vestigial or subliminal action. On the other hand, “abnormality” might well consist of an unusually high propensity to use such inhibition:- conscious “suppression” of otherwise spontaneous tendencies, or unconscious “repression” of them — leading to neurosis in some cases).

“Noun” concepts may be identified with the rather more complex <207> “sets” or lists of other elements — often having mathematical “group”-properties — described above in Section C2.4, and also in Chapter A3, and Traill (1975b, 1975c, and 1976d).

#### *The Neo-Piagetian approach to Ashby’s third problem*

These *Action*, *Verb*, and *Noun* concepts should now be fitted into the context of the supposed hierarchical control-structure discussed in Chapter A3 and in Section C2.3, above. Let us start by considering just one level insofar as that is possible; and for this purpose, let us choose the level predominating in an infant of about one year old — half way through the sensori-motor period. Here “action” concepts refer to such hereditary reflex actions as sucking, grasping, kicking, smiling, and crying — and also learned modifications to these schemes (Section A3.7, above). But it should be noted that none of these action-patterns is a straightforward simple action of a single muscle; in each case there is already a considerable degree of organization, including temporal and sequential considerations. Clearly then, we should not delude ourselves that these actions of the sensori-motor stage lie on the bottom level of the hierarchical-pyramid; but rather there must be at least one other level below them, with its own (genetically determined) set of structural devices. Nevertheless, as adults we tend to take both these levels for granted in our daily life — if we ever notice them at all. From that “common-sense” point of view then, it seems reasonably in accord with everyday thinking to rate them as being of order “0 and -1” respectively; and this fits in with the nomenclature used in Section C2.3 where the simpler phenomena of the sensori-motor period were said to be at the “ $m^0I$ ” level. Presumably then, we might reasonably talk of individual-muscle activity as being at the “ $m^{-1}I$ ” level — or at least within the broader category of an “ $M^{-1}L$ ” level.



From a formal point of view then, the assignment of the zero (to  $n$ ) for the “ $m^1l$ ” scale has been done arbitrarily — serving, if nothing <208> else, to emphasize the existence of some misconceptions built into our culture: comparable to talking about the Sun as “rising and setting”. But in any case we would be wise to be cautious in our interpretation of  $m^1l$  values:- Even assuming the present basic theory on hierarchical organization is correct, there is no guarantee that we have identified all the relevant stages and their true interrelations. There may be at least one extra full (“double”) level between what we have happened to call “ $M^0L$ ” and “ $M^1L$ ” (in Chapters C2 and C3); and the hierarchical organization may not be as simple and linear as we would like to believe. After all, family relationships do not always observe neat proprieties of generation-separation — so that aunt-nephew or father-daughter matings are possible, even if they are not regarded as proper; and who is to say that our supposed hierarchy will not break these or other rules? It may do so to some extent under normal conditions — especially if it is physically split up into poorly connected regions; and it may do so even more in pathological cases, as we shall see. It is possible that these irregularities, if they exist, may be connected in an intelligible way with EEG (electro-encephalogram) tracings, bearing in mind that effective trial-times are likely to increase appreciably for the more sophisticated control-loops in Ashby’s system (as mentioned at the close of Section C5.1) so the slow waves of the EEG might have a particular association with the higher  $M^1L$  levels.

209

Anyhow, we were considering the action-codings within that level of organization which has now been labelled as “ $M^0L$ ”, and for this level we should be clear that we are talking about “actions” as calls to  $M^1L$  structures which *then* activate the actual muscles. Next it will be well to recall some of the details as postulated previously, (Sections A1.3 to A1.5, and Sections A3.1 and A3.2, above). <209> Isolated linear elements or “tapes” were seen as essentially unstable or at least vulnerable in a competitive environment. Survival for such codings was seen as taking one of several forms: either they were hereditary and so readily replaceable from genetic sources, or they attained a collective stability through joint participation with other such elements, or else they acquired a “tag” of approval which afforded them some measure of protection from dissolution and/or enabled them to replicate. Following Piaget’s terminology, the collective effect of the more ephemeral elements (including the replaceable hereditary elements) were termed “schemes”, while the collective effects of the stabilized elements were referred to as “schemata”. The non-committal term “schemoids” was used to include both cases, and its use is convenient to evade some confusion as to whether the stable *patterns of behaviour in a reflex* should be considered as schemes or schemata; (Section A3.2, above). In the light of our current discussion, we may now reasonably suggest that they are schemes *from the  $M^0L$  viewpoint*, though we might well consider them as schemata at the  $M^1L$  level — if we accept the legitimacy of this terminology for such a primitive level.

210

### *On fitting the Ashby and Neo-Piagetian models together*

It remains now to identify the dominant “verb” and “noun” types of entity for this stage of development, given this postulated collection of linear elements. In the third paragraph of this section we have already taken the “verb” entities as being reversibly inhibited action entities, and clearly it will make sense for us to stipulate that these should be  $M^0L$  action entities; however no mention was made there about stabilizing-influences in such cases, and this is something which we should now consider briefly. The predominantly symbolic role of such structures would seem to militate against direct strengthening-through-use, thus arguably weakening the case for both the tag reinforcement method and the passing-of-a-signal-<210>around-a-closed-circuit method. However, as has already been suggested, such active roles may be intermittently restored in some sense during certain sleep modes — for the very purpose of promoting such selective stabilization.

211

We have already identified “noun” entities as being list-structures of some sort, presumably defined predominantly by extensive means, and preferably having a substantial degree of internal closure within themselves so that they have some claim to being embodiments of mathematical groups. It is envisaged that the constituent members of such lists will be inactivated action codings, and we would expect these to be of the  $M^0L$  type, (though it is not clear whether these members would already be intermittently-inactivated “verb” entities before they become listed, or whether it is the listing process which inactivates them. On balance, we might favour the former alternative as representing a stepwise imposition of control; but then this could be construed as an unnecessarily time-wasting strategy (Ashby, 1960, Chapter 11). In fact there seems to be no particular reason why both types of entity should not be eligible for membership on such lists, so let us provisionally accept this to be the case).

[This is a case of what we may choose to call “*the pluralistic principle*”: that when there are several ways in which a biological mechanism might work, and they appear to have comparable probabilities, then there is a good chance that all of them are actually operating in parallel — or operating alternately, according to fluctuations of circumstance. Indeed the concept might profitably be extended beyond biology to complex mechanisms in general — including the case of chemical resonance. Even when one of the alternatives is rather improbable, it is probably fair to imagine that sooner or later such improbable methods will be “tried”, whatever the consequences might turn out to be. a similar principle may also be stated for cases <211> where the *function* of a structure (such as the urethra in male mammals) seems to have more than one possible use. Often it will be profitable to postulate that it *does* have multiple functions — thus increasing the chance of side-effects if we try to alter any single one of these functions. These two different variations on the general theme might suitably be distinguished by separate titles: the “redundant mechanism” principle, and the “multiple function” principle, respectively].

212

Anyhow, because such list-structures must necessarily await the appearance of the “verb” and/or “action” elements before they can build up and appear as “noun” entities, there is some logic in dividing the control level of the hierarchy up into two parts: lower and upper —  $m^0l$  and  $m^{1/2}l$ . This also seems to tally with Piaget’s division of his Sensori-motor and Operational periods up into “A” and “B” subperiods; (and this would hardly be surprising, because it was in fact the Piagetian notion which first suggested the  $m^0l/m^{1/2}l$  type of double-stage mechanism — repeatable at higher levels).

#### *Adding a third component — the coexisting “Textbook Synapse-and-Action-potential” account*

We may now turn to the  $M^{-1}L$  level to consider what mechanisms may be involved there, and the nature of their interface both with the  $M^0L$  level and with the outside world. Whereas the basic action elements of  $M^0L$  were seen as sending off their sequential orders in an “intensively defined” form (using specific callsigns to select their targets), the  $M^{-1}L$  action elements must presumably come down to earth and send *their* orders down efferent nerve fibres (each defining an “extension”) — and presumably using straightforward Hodgkin-Huxley (1952a, b, c) action potentials, more-or-less in accordance with the accepted view: (Eccles, 1964; Katz, 1967). It seems then that the output side of  $M^{-1}L$  will entail an explanation of how the postulated intensive calls of the linear micro-element theory could become transformed into (amplified) extensive signals <212> destined to bring about muscular changes.

213

No detailed explanation will be attempted here, but some general ideas will be outlined. Firstly, initiation *or modification* of motor signals by “intensively defined” calls must presumably arise through some sort of chemically-induced action at non-myelinated locations:- cell-bodies, dendrites, unmyelinated axons, or Nodes of Ranvier. (Hence all such sites are feasible locations for  $M^0L$  processes, especially when the neuron concerned happens to be an interneuron).

Secondly, since we are dealing with highly stereotyped actions, there seems to be no pressing need for the driving “chemical” activity to be located in a central brain; — local reflex centres should be adequate. Much of the neural activity of invertebrates would seem to be of this sort, and what little learning there is may plausibly be explained in terms of *locally situated* (Horridge, 1962)  $M^0L$  linear action elements, together with the mutations and “crossovers” amongst them; (Traill, 1976b; and Section A3.4, above).

Thirdly, it should be borne in mind that the Hodgkin-Huxley propagation along unmyelinated neural membranes has some obvious chemical aspects. These appear to be predominantly governed by trans-membrane electrostatic potentials, but it is possible that these may be at least *modified* by information emanating from  $M^0L$  action elements: for instance by altering the postulated infra-red components of the Hodgkin-Huxley action-potentials (Traill, 1975b, 1976b; and Part B, above), or simply by altering thresholds. This may be what is happening during the disruption (“blocking”) of the resting-state alpha-rhythm EEG tracings, when “thinking” activity begins. After all, it would not be difficult to imagine that such “calls” from collective micro-elements might be in a position to control the release of energy from mitochondria, thus functioning like the grid in a triode valve to produce amplified effects; and <213> no doubt there may be other feasible methods which could be used for such amplification. Incidentally, it is worth bearing in mind that EEG rhythms, as measured, have been located as coming from apical dendrites, (Gray-Walter, speaking at Brunel University, 1976).

214

Fourthly and finally; as far as I know, there has not yet been any adequate explanation as to what precisely causes the vesicles of Acetyl Choline (or whatever) to rupture and spill their chemical message into synaptic clefts. (One might perhaps be forgiven for supposing that some workers in this field are content merely to *name* this process as “exocytosis”, and accept this as a substitute for explanation! But actually, of course, they are presumably just awaiting some “hard” evidence before attempting such an explanation; however such evidence is very slow to appear — as is so often the case in this ultra-micro field of investigation). Anyhow, it seems likely that this exocytosis may be set off by specific types of (coherent infra-red?) “calls” from linear micro-element sources — or else set off by some other agency with at least some features in common with these “action elements”.

But the  $M^{-1}L$  level will also have a traffic in *input* sensory signals, and not just the output actions which we have been discussing. Hubel and Wiesel (1959, 1961, 1962, 1963a, 1963b, and 1965) have done much to elucidate the more-or-less automatic stepwise processing performed on a visual image during the passage of its effects from the retinae, through the lateral geniculate body, to the striate cortex and beyond. Such accounts naturally tend to focus on those effects which are observable in the laboratory situation, so we would do well to be awake to the possibility of other ramifications of this process; and we might profitably also give some thought to *how* such a system might develop its structural detail under the joint influence of genetic coding, and interaction with the environment — <214> or lack of it (Hubel and Wiesel, 1963a, 1963b). Nevertheless, we shall leave aside such details here, and consider more generally what it is that this whole string of processes amounts to:-

215

There seems to be a somewhat arbitrary distinction drawn between the gross layout of the overall picture and the fine textual detail. The gross layout is “mapped” onto the new regions more-or-less intact — maintaining its *extensive* properties; however the textual detail (including dynamic aspects) is “analysed” or “interpreted” into a *different type of extensive definition* — with specific screen-display patterns<sup>43</sup> being “identified” and turning up as action-potentials in

<sup>43</sup> many elements of which might justly be described as *intensive* in nature — so the interpretive process seems to be translating in the wrong direction. However, if we consider that the intensive properties (such as *physical* colour patterns) are external to the individual and probably in an unusable intensive

specific neuron cells (and thus being sorted into positional “slots” ). If this input process is to be the reverse of the postulated output process, then we would expect this processed set of extensive codings to be subject to still further processing until it ended up in an internally usable intensive form.

*Extending Piaget’s ideas into the more elementary domain*  
— (pre-sensorimotor:  $M^{-1}L$ )

According to the Piagetian view, perception is no mere passive acceptance of whatever manifests itself at the sense-organs, but rather a consequence of *active* internal manipulation of such material (based on the original physical manipulation of relevant parts of the environment). This concept is of fundamental importance — though even today it has not been widely understood. In fact, we <215> might perhaps sum up Piaget’s main contribution as an application of this concept to phenomena which we, as adults, tend to take for granted as “basic” — discrete objects, phonemes, the concept of “mother” or even “original sin”! Re-examination from a Piagetian point of view suggests that many of these supposedly basic units are not necessarily basic at all, but built up experientially at an early age (or in one’s ancestors) as described in the postulated detail of how an object concept develops (Traill, 1975b; and Chapter A3, above).

216

But this breakthrough was at the  $M^0L$  level, and we have now turned to a discussion of the  $M^{-1}L$  level; so does the same principle apply here too? Perception of edges and bars etc., with specific motion and orientations, would appear to be the basic units of  $M^{-1}L$ ; so do we come to an appreciation of their potential value through association with some *action* which we ourselves initiate? Well, while it is possible that something of this sort might take place here<sup>44</sup>, it nevertheless seems that there must be a stop to this <216> subdivision process eventually. Sooner or later we must “hit rock bottom” in that our sense-organs will simply be unable to discriminate any further remotely meaningful detail among the signals from the world outside; indeed it might be argued that the outside world will itself eventually reach a bottom limit of structural detail. Whether such basic units of mental concepts are to be found here in the  $M^{-1}L$  level (or any lower level) is thus open to question. However as the outcome of any such discussion is unlikely to have any crucial bearing on the issues of this present work, we may leave the question open — but meanwhile provisionally assume that  $M^{-1}L$  is the lowest level, in which case concepts such as specific edge motion-and-orientation *will* be basic. In any case, it is difficult to see what would be gained by extra flexibility at this stage because configurations like this would seem to be adequately ubiquitous and basic.

217

---

form, then it makes better sense to think of such visual impressions as being translated first into a more manageable extensive form — and then, if necessary, re-translated into a different (internal ) intensive form. After all, such procedures are commonplace in computer practice, and in the use of coordinate systems .<215>

<sup>44</sup> At some stage, development is likely to be governed by what I have elsewhere referred to as “ortho-maturational” processes. These might be regarded as being half way between straight genetic development and learning-process development. Whereas true learning can explore a number of unforeseen possibilities in an open ended and reversible way, ortho-maturational development is essentially genetic but with the implicit “assumption” in its coding that the environment will provide certain recognizable cues at appropriate times. Imprinting is one apparent example, and the development (and maintenance?) of optical pathways into fully functional systems may well be another.

In a trivial sense, of course, all genetic development must be ortho-maturational to some extent. For instance, it will nearly always “assume” that the environment will never manifest a temperature of 100°C in the organism’s own immediate location. <216>

Anyhow, whichever one is the fundamental basic level, its “noun/verb/action”-content will be rather different from the other levels. As far as the Central Nervous System is concerned, signals enter and leave carrying codings which have meaning only by virtue of (i) the fibre in which they are travelling (extensive definition), (ii) the pattern of action-potential pulses along the fibre, and perhaps (iii) interaction effects between different fibres; — at least that is the accepted view, and there does not seem to be any pressing need to challenge it as the means for sensory and motor *peripheral* communication (though the present work obviously contains different proposals, involving infra-red, for the mechanisms appropriate for *higher* mental processes — including such lowly activities as *channelling* reflex emergency responses). Thus it would seem that any structure in the coding of the entities of this lowest level will have been imposed from elsewhere, so the entities themselves will apparently lack structure of the “linear micro-element” type, <217> which means that the noun/verb/action distinction loses significance. This seems to mean that there is no room here for the abstract difference between such a signal and the “thought” of it. It will operate or not operate, as the case may be, but there is no symbolic contemplation of that particular signal by the animal or person concerned.

218

### Other thoughts about mental hierarchies

It will now be left to the reader to consider whether bacteria, plants, or computers (as usually programmed) could be said to operate at this level of “thought”. I suspect that this exercise might not be as frivolous as it appears at first, and that it might shed some light on the historical development of thinking, as well as giving some further insight on what constitutes the “lowest level” (if indeed this concept is valid) and related questions on “how to emerge from a recursive process”. However, it seems that a full development of these questions here would take us too far from our main topic which is more concerned with the “higher” levels of thought.

We have been discussing the processing of information of a textural/edge-detection/colour type — information which can be attributed to a small local area on the retina (or corresponding local areas in other sensory or motor systems). But as we have seen, these “points” will often form a gross topological pattern which will be transmitted more-or-less intact right across the brain, and despite the considerable amount of processing which has meanwhile been happening to the “textural” information. I would suggest that it is, in fact, beyond the competence of the  $M^1L$  mechanisms to deal with information of this sort — with its almost astronomical variety of potentially meaningful configurations (unlike the limited “textural” repertoire whose information it will also use). a different approach is required in such circumstances, and this is provided by the Piagetian paradigm of: “arbitrary action first, and then see if the <218> outcome seems to tend towards meaningfulness” — as already described for  $M^0L$ , the level which will presumably be required here.

219

Simpler animals will probably make do without such gross holistic analysis. Ashby’s remarks (1960), that it is fallacious to believe that a brain must be richly interconnected, would seem to be particularly applicable here. Indeed one might say that the only justification for interconnection within parts of the brain is the need to handle situations in which the meaningful cues are of at least this complexity; and arguably this handling can only be done by using  $M^0L$  mechanisms, or higher. In this context, it is interesting to speculate on the significance of various anatomical sites in the brain, and why new structures of various sorts have appeared at particular stages of evolutionary processes. Plausibly  $M^0L$  would initially be absent, or present only locally at isolated sites without any need for a *centralized* “brain”; and later it might achieve such centralization in the “old brain” in such structures as the optic tectum. Presumably these old structures were incapable of being modified to cater for new higher levels such as  $M^1L$  and  $M^2L$ , and so they became something of a historical curiosity (with some vestigial powers) when there arose, fortuitously, a new structure which did have such capability, and clearly the

disproportionate size of the *neocortex* in mammals makes it look very like the sort of structure we would have in mind.

→ Full Self-organization — C5.4 Concept-structure types

**TABLE C5.4/I**

**Postulated schematic organization for the micro-structures in the various levels in the hierarchy of mental coding and control; see text.**

(“ ---> ” signifies informational dependence, and also subsequent potential for control).

Level	Piagetian Stage at which this level first becomes important	Corresponding salient ages	“Noun” “Verb” “Action”	Comments	Guess at plausible main site in Nervous System
M <sup>3</sup> L	_____?	?	<p>“Noun” → “Verb” → “Action” →</p> <p>(etc.?)</p>	? “Algebra of algebras” ? Mutant “strings” found capable of manipulating M <sup>2</sup> L structures (as a generalization of them).	{ Cerebral Cortex (Neo- cortex) } Older brain-sites: tectum etc. + Sensory & Motor Cortex Peripheral <221>
M <sup>2</sup> L	Formal Operations	16+ 11+		Separate algebraic and logic systems. Inactivated “strings”, symbolizing set-manipulation: the essence of algebra. Mutant “strings” able to manipulate “obvious” sets.	
M <sup>1</sup> L	Concrete Operations	7+ 2+		“Obvious” sets:- of objects, etc. Inactivated “strings”, symbolizing object manipulation (etc.). Mutant “strings” able to manipulate M <sup>0</sup> L structures.	
M <sup>0</sup> L	Sensori-Motor	1+ 0+		List-“strings”, incl.obj. concepts: Fig C5.2/3 Inactivated “strings”, symbolizing action-patterns. Hereditary action-pattern “strings” (+ mutants).	
M <sup>-1</sup> L	(Basic)	pre-natal		Afferent and Efferent Tracts	

As for recursion (discussed above in Chapter C3); it would now seem likely that  $M^{-1}L$  and  $M^0L$  will use different mechanisms from each other, and indeed there may well be at least two different types of mechanism in use for  $M^0L$  (corresponding to the supposed alternative sites in the archecortex and neocortex). It is possible however that  $M^1L$  and higher levels may all use the same basic linear microelement pool, and that the distinction between the different levels <219> will be maintained autonomously and adaptively using internal devices (such as “tagging”) inherent within the system itself. Moreover the “neocortex type” of  $M^0L$  might well also be a party to the same sort of method, which would seem to give us the option of a complete recursive arrangement for all but the basic  $M^{-1}L$  level. (This option need not necessarily be used for all purposes, as in cases where the archecortex is still significant). It should be noted that such an elaborate recursive system, with potentially flexible roles for the constituent elements, is more *vulnerable to malfunction* than a less sophisticated inflexible system; and we will return to this issue in Chapters C6 to C8.

220

Table C5.4/1 summarizes some of these hierarchical  $M^nL$  concepts which we have been discussing. In particular it shows how the postulated fundamental linear action-elements of each level ( $n \geq 0$ ) are supposed to depend on the Noun and/or Verb structures of the next-lower level to provide them with meaningfully stable referents. In their turn, these Noun or Verb structures are presumed to refer, directly or indirectly, to the linear action-elements of their own level. The Table also implies the question of whether any recursive build-up can continue beyond  $M^2L$ ; and if so, then how far? In other words, can we form an abstraction of an abstraction — of an abstraction ... (and so on), without losing track of what we are doing, and without delegating our task to some essentially mechanical outside aid?

Of course we must expect that the real brain system will be rather more “untidy” than the comparatively neat arrangement here. Not only are we likely to have such things as old and new types of  $M^0L$  system, but it would seem likely that there will be other duplications of (e.g.) the visual gross field into areas “I and II” (Thompson, 1967, p 316 — after Woolsey, 1958) *within the new* <220> processing lobes. Moreover, there will almost certainly be irregularities and exceptions in any such arrangement, so we would be well advised to bear this possibility in mind.

222

### C5.5 Completing the review of defects in Ashby’s exposition (as listed by him) <E<sub>2</sub> etc now not u/lined!>

At this stage it should now be possible to give a reasonable explanation of Ashby’s “third conundrum” (if we may call it that): how a natural biological system could establish its own “gating mechanism”. Let us first remind ourselves of the elementary situation shown in Figure C4.4/1, in which the organism responded to an unsatisfactory response-pattern by a random change into some other arbitrary response-pattern, and (so to speak) hoped for the best! While we may accept this sort of change as occurring *in principle*, it will now be necessary to take issue with it concerning matters of detail in the mechanism:- Ashby is clearly thinking mainly in terms of gross “nuts and bolts” models, as described in his Chapter 8 (1960), whereas our concern here has become one of *populations* of cooperating and competing micro-elements — for which it will not quite do simply to say of *gross* behaviour-patterns that they are “switched” on or off; so further elaboration is needed.



*Applying the above discussion to Ashby's third problem  
— on explaining gating-mechanisms*

In terms of the linear micro-element theory, we may suppose that the “Responder” in Figure C4.4/1 consists *mainly* of linear elements with a specific hereditary action coding<sup>45</sup>, though there will also be *minorities* of mutants, thus implying possible alternatives, but whose existence or growth will not be encouraged while the organism remains in a “comfortable” state. Plausibly the most <222> prevalent type of coding (sensitive to *this* E<sub>1</sub>) will be the one which will actually lead to action; and in some sense we may say that it is holding the organism’s “attention” (Without necessarily implying that this attention will be conscious). If attention, in this sense, means that *its* programme of action is the one which forms the response R; and if it also “gets the blame” whenever E<sub>2</sub> detects that the outcome is unacceptable; then we can see how the response-pattern may become “switched”. Thus “getting the blame” will entail a dissolution of at least some of those elements which are “under attention” — either directly, or via unfavourable tagging. This will tend to allow some rival coding to increase its relative numbers and eventually capture attention from the original coding.

223

[Without actually using the term “attention”, this concept has already been discussed above (in the early paragraphs of Section A1.4). There, the linear elements were described metaphorically as being called (by an E<sub>1</sub>-type stimulus) “to report to a particular control centre”; though it was pointed out in the footnote that the “control centre” should be interpreted in terms of “*communicational proximity*” rather than the spatial proximity implied by the terminology. However there was no clear indication given as to what form such “communicational proximity” might entail; so let us now specify something more definite. It is conceivable that this could be attributed to *gene-like* switches on the linear-elements (with “on” signifying “attended to”), perhaps dependent on sleep-or-mood state as postulated above for the formation of “verb” elements; but we may be inclined to think that such a mechanism would be too passive, sluggish, and unwieldy as an explanation for “attention”. Alternatively we might consider *excited quantum states* (rather than chemical changes) as a somewhat more credible switch mechanism for constituting the attention-state. This would seem to be more clearly reversible, <223> especially under competition, and more readily established under suitable circumstances. Various degrees of stability might be obtained, depending on potential barriers or on a possible propensity for some states to trap any further hyperactivating transmissions which might be available — a form of positive feedback].

224

So, looking again at Figure C4.4/1, we would apparently do better to think of the “responder” as a sort of consensus ballot-box, activated by a multitude of “micro-responders” — each with its own (micro) switching system of one sort or another, and in danger of liquidation if its performance in office is not up to scratch, for whatever reason! This would be more accurately represented in Figure C4.4/1 if the “responder” and “switch mechanism” boxes were combined, though this would still not quite do justice to the supposed infrastructure. Anyhow, we may presumably identify this combined subsystem with the **M<sup>0</sup>L** level which we were discussing earlier — and moreover this will mainly entail use of the *action* entities of **M<sup>0</sup>L**.

Coming back now to Ashby’s “gating mechanism” as depicted in Figures C4.5/1 and C4.5/2, we may recall that its purpose was to *select* a switching-mechanism (S<sub>i</sub>) *appropriate to the current situation* or “sub-environment” (P<sub>1</sub>). In terms of the present version of the theory, this would seem to mean selecting the *appropriate subset* of micro-elements (from those sensitive to the E<sub>1</sub> in question) and allowing only this subset to respond overtly to the stimulus pattern E<sub>1</sub>;

<sup>45</sup> Here we are considering only those elements which are susceptible to the *particular* input stimulus E<sub>1</sub>. There would presumably be many others which would remain passive here, but would be roused by other types of E<sub>1</sub>.<222>

though if the general “situation” had been different, then some other subset of micro-elements would have been chosen. Such a process may be likened to the selection of a sport-team specifically to suit the prevailing conditions of weather (etc.) on that particular day. It is incumbent on the selectors of such a team to “have in mind” alternative *subsets of criteria*, and to use the right subset for that set of conditions. <224>

It may be that the appropriate criterion is very simple and straightforward. Perhaps the same pool of potential players is to provide a basket-ball team on Monday, and a team of rowers for Thursday; and conceivably the over-riding criteria for the two cases would be: *height* for basket-ball, and *weight* for rowing. Simple criteria like these can readily be expressed by *intensive* specifications:- “Tall men over here please, whoever you are!”; (and this seems to be very much the same thing as applying an “objective test”). But such decisions will normally be more subtle or “subjective”, and depend heavily on experience; and this “experience” can be interpreted as a pragmatic evolutionary selection amongst arbitrarily established sets — defined *extensively*.

225

Whatever the physical mechanism is that holds such successful subsets of  $M^0L$  elements together, it will evidently be taking on the role of an  $M^0L$  “noun” element — acting as a link to  $M^1L$  action-elements, as depicted in Table C5.4/1. We may recall that the mechanism for forming a physical extensive set could be:

- (i) enclosure by a physical envelope such as a cell membrane,
- (ii) the somewhat improbable direct tethering to the  $M^1L$  linear element itself, and/or
- (iii) symbolic tethering by having “names” of the member elements attached to the  $M^1L$  element — and depending *partly* on intensive definition to give the “names” a meaning. See Sections C5.2 and C8.1.

While the enclosure method (i) would doubtless suit admirably for more-or-less permanent subsets like those envisaged for  $M^1L$ , any potentially evolving system of subsets would seem to need a more flexible-yet-controllable arrangement such as symbolic tethering (iii).

Anyhow, this provision for control by the  $M^1L$  structure now leads us to identify this control-path as the “gating mechanism” postulated by Ashby. From there, it is a comparatively simple matter to use the <225> above expositions to answer his conundrum as to how such gating-mechanisms might arise. We may suppose that the potential  $M^1L$  linear elements arise arbitrarily, in largish numbers, by some process of mutation. These will have inbuilt sensitivities to various situations, using input codings of a type which will turn out, in successful cases, to be different from those input patterns ( $E_1$  in Figure C4.5/2) which are used for activating  $M^0L$  systems. The new type will be identifiable as  $E_3$  in the diagram, but in any live situation it may well be a matter of some considerable subtlety to distinguish which input cues are to be considered as  $E_1$ , and which are  $E_3$  as we shall see in Section C6.5. And then the situation is further complicated by the need to consider *evaluative* feedback-input:  $E_2$  for the  $M^0L$  case, to which we may now add  $E_4$  for the  $M^1L$  case — thus introducing another feedback loop into the configuration of Figure C4.5/2.

226

In addition to their specific sensitivities to incoming signals, these elements will also have definite inbuilt codings for “actions” of various types. But in the successful  $M^1L$  elements, these “actions” will apply *internally* to the structures of the  $M^0L$  level, and not to the motor-effectors as would be the case for  $M^0L$  actions.

So the answer to Ashby’s third conundrum would seem to be: that the gating mechanism consists of a population of  $M^1L$  linear micro-elements, and these evolve into effective systems in an essentially Darwinian trial-and-error way. Provided that we can sort out the tangle of feedback loops satisfactorily, this process can be seen as being a learning procedure within the life of each individual concerned — and essentially operating on the same principles as the basic learning process used to improve the  $M^0L$  repertoires of responses. The crucial difference will be the

destination of the action signals, and the nature of subsequent derivatives which will presumably arise from the “inactivation” <226> of such codings; but we may also expect other incidental differences such as a new pattern of sources for the input signals.

227

Before we move on, however, there is a rather important further point which should be remarked upon — albeit with unseemly brevity. If we can have a “gating-mechanism” system to bring orderly “purposeful” operation at the  $M^0L$  level, instead of the random re-settings used in Ashby’s simpler “Homeostat” models; then why not have a *higher level* gating system to bring a methodical approach to the original one at  $M^1L$ ? Why not indeed? Provided (once again) that we can cope with the extra complications of further feedback loops, we may well assign such control to an  $M^2L$  level; and then why not continue recursively to higher and higher levels (until lack of coherent structure in the organization of the outside world renders it unrewarding to put further structure into our modelling system)? It is tempting to suggest that, in principle, that is very much what happens in the human brain; and that it is this very recursive ability which gives to man his superior place on the scale of intelligence. Like most elaborate mechanisms, however, this arrangement lends itself to a new set of possible misfunctions; and this will be our chief concern in most of the remainder of this current work.

At last then, we have disposed of Ashby’s third conundrum. Let us now move on and look at his fourth:-

#### *Ashby’s fourth problem — maintaining a balance between parts of the system*

(4) Ashby was concerned that he had not explained how the body might maintain a reasonable proportional balance between those “parts” of the system which were in equilibrium at any given time, and those parts which were undergoing a change at that time — thus determining the pattern of changes in the next “instant”. This would seem to be a much simpler question than his previous one. Presumably, like many well-known physiological devices for maintaining one variable or another within appropriate bounds, the process may be explained in <227> comparatively straightforward *servo-mechanism* terms.

228

Our present theoretical context does rather complicate the issue however. To start with, Ashby was clearly thinking of his system’s “parts” as being whole neurons (1960, Section 13/12); and while he might well be right as far as  $M^1L$  processes are concerned, we should now keep in mind the idea that for many other processes we are likely to be dealing with excitation-states at more-or-less discrete sites along linear molecules. Secondly, the hierarchical structure proposed above puts a rather new slant on his concept of local stabilities, as discussed in his Chapter 13; — not that this invalidates his argument here, indeed it could well be claimed that the revised interpretation adds weight to it, but it does alter the implications somewhat.

There is a third complication which amounts to a generalization of some points which Ashby himself mentions in passing. Signals cannot be counted on to add up neatly in any given way: arithmetical, algebraic (taking inhibition into account), Boolean logic, or whatever; (Ashby, 1960, Section 13/12; cf. McCulloch and Pitts, 1943). This has become increasingly obvious for real extended neurons in which the important signal components are presumed to depend principally on action-potentials (including refractory-period phenomena), exocytotic rupture of vesicles of transmitter chemicals into synaptic clefts, and other such mathematically “untidy” phenomena. The quantitative situation for linear micro-elements has scarcely been discussed yet, but there is little reason to suppose that the “addition” of signals would obey absolutely neat mathematical rules here either — though almost certainly there will be addition of some sort, if only in the form of mutual facilitation as in Figure C5.2/2, above. The situation could be particularly complicated if “optical” interference patterns between signals should play an important <228> role (Pribram, 1971), possibly involving the coherent infra-red sources postulated for the micro-element theory (Traill, 1976b; and Part B, above).

229

Despite all this untidiness concerning detail, there does not seem to be any great problem here regarding general principles (unlike the fundamental issues raised in Ashby's third conundrum, above). At a practical physiological level, we may reasonably assume that such control mechanisms either depend on some natural self-limiting process around which evolution has "designed" the rest of the system, or else some system parameters are set genetically on a trial-and-error basis. (One component may be unmodifiably hereditary, but other aspects might be subject to learning in the manner previously described using the concept of mutation-within-the-nervous-system). Moreover, at a basic ultra-micro level of resolution, we might reasonably expect to find ultimately that the mathematical untidiness would disappear — though we would then be left with the same sort of untidiness as soon as we attempted to "put the parts back together again". This might then be best dealt with on a statistical basis — perhaps even using statistical mechanics techniques borrowed from physics.

There seems to be no pressing need to develop these ideas here in a generalized way; instead it will suffice to develop specific cases if-and-when they become important. However we may usefully draw attention to some places in which these concepts have already arisen:- There was the stability of mental schemata arising from their supposed "mathematical-group" closure-properties (Traill, 1975b; and the last two paragraphs of Section A1.5, above). There was also the phenomenon of positive reinforcement, the mechanism of which could be of the type sketchily described in terms of "tagging" (Traill, 1976b, Figure (v)b; Traill, 1976d, Section B). However <229> any limit needed here will presumably be supplied by some obvious natural limitation; whereas Ashby's problem was to explain why only a sensible number of "parts" were active at any instant — neither too many nor too few. Of course, it may well be that there is a natural limitation here also; and conceivably this could take the form of a breakdown in effective coordinating communications whenever too many "parts" are trying to function simultaneously creating too much "noise" for each other's coherent infra-red signals, or whatever. And incidentally, a similar type of "jamming" phenomenon might be behind the "displacement" behaviour described by ethologists, in which the animal is "torn with indecision" between two mutually incompatible instincts — so he "ignores" *both* alternatives, and does some other (less pressing) activity! (Tinbergen, 1951).

This half-answer will suffice for our present purposes, so we may now turn to Ashby's fifth and final conundrum (1960, Section 17/11).

*Ashby's fifth problem — Which M<sup>n</sup>L level should receive which input?  
— A topic for Chapt.C6*

(5) Under the heading "Distribution of feedback", Ashby poses the problem of how any given disturbing change in the environment will be "steered through" *the appropriate*  $E_i - R_i$  path, where  $E_i$  is the appropriate "essential variable" and  $R_i$  is the corresponding appropriate response. In terms of the linear micro-element theory, part of the answer will now be quite straightforward:- At any given level in the hierarchy which involves learning, the "paths" will be name-called, with considerable precision, *in advance*; but many such specifications will be found to be non-adaptive, and will be eliminated in a Darwinian evolutionary process. However there is another part of the answer which remains anything but clear:- How does such a living system choose *which hierarchical level* to incorporate new information into? In other words, should a given input pattern be associated with  $E_1, E_3, \text{ or } E_5, \dots$ ; or as an evaluative feedback  $E_2, E_4, \text{ etc.}$ ? This is a major concern of Chapter C6, to which we will now turn. <230>

## Chapter C6

**THE SYSTEM LOOKED AT AS A WHOLE,  
AND SOME INHERENT WEAKNESSES TO BE EXPECTED**

231

## SUMMARY OF CHAPTER

This chapter concerns itself, in a broader and less-specific way, with those “emergent” properties which are likely to arise in a large integrated system, or which are actually observable and need to be accounted for. In particular, likely non-adaptive by-products of sophisticated developments are suggested, on theoretical grounds, as a prelude to the systematic discussions of neurosis and psychosis in Chapters C7 and C8 respectively.

**C6.1 When should it be feasible to mount a frontal reductionist attack on the perennial problems of psychology? — including such intangibles as Attention, “Mental Energy”, Ego, and Morale**

It will be important here to clarify what is meant by “reductionist” and “frontal attack”, in this particular context. The *reduction* contemplated here entails a chain of causal *functional* explanations — stretching from behavioural phenomena down to the supposed functional elements from which the system appears to be constructed. Ideally these elements will be identifiable physiological or biochemical structures; but it will be held to be sufficient here if they can be narrowed down to sets of a manageable size, such as “linear molecules like RNA”, or “signals involving coherent infra-red emission”. The main point is that their functional role should be definable with sufficient precision for us to be able to make definite predictions about the operation or macro-characteristics of the system as a whole (Popper, 1934/1959, 1963/1969). [But note that the testing of such predictions need not just be by traditional experimental methods; we should also seek validation of the macro-model by means of “internal closure”].

Another requirement for a reductionist system — as conceptualized in this work at least — is that the basic elements should be self-organizing rather than having to be ultimately created by some transcendental “programmer”; (see Part A, above; and Traill, 1976e, Chapter VII). Hyland’s analysis (1977a, 1977b) is also of interest in this context. He divides *hypothetical constructs* of psychology into three categories: Mentalistic, Mechanistic, and Physiological — and suggests that these cannot legitimately be mixed within any one explanation, though one may be used to interpret or explain another. It looks as though his *Mentalistic* category deals with entities like “ego” which, as they stand, (in Freudian theory), do not have enough precision to build up any extended theory in detail — though it seems reasonable to claim that a modest amount of closure can emerge from *ad hoc* psychoanalytic situations, when the conditions are sufficiently favourable. (It should be noted that this is no mean feat, even if we may hope to do better some day. Major advances in our knowledge will usually have to come in stages — and dearly bought at that!)

To the best of my knowledge, all computer-like models of mental functioning have always been *Mechanistic*<sup>46</sup> in Hyland’s sense, and I take this to mean that they are never fully conceptualized as being self-organizing. In fact it is now easy to see that Chapter C5 was an attempt to convert Ashby’s “Mechanistic” model into a “*Physiological*” one in Hyland’s sense — which I take to mean “radically reductionist” (to the extent that one continues reducing, in

<sup>46</sup> My own use of the term “mechanistic” has been somewhat broader — including the physiological type of mechanism as well; (but then I have gone in for a further reduction below the usual concepts of physiology).<232>

principle, until the elements or substrate seem to have become irreducibly simple — whatever we take this to mean).

When we base a model system on elements which are hazily defined (e.g. Mentalistic) or on elements lacking recognizable provision for <232> self-organization (i.e. “Mechanistic” in the above sense), then in both cases our model will only be a qualitative approximation to the real natural system which it purports to represent. [We are here assuming that such natural systems do have these properties of ultimate discrete structure and self-organization, at least to a substantial degree]. Such approximations are very often the only way in which animals (including ourselves) can cope with the initial mysteries of the environment — so we should accept the necessity and importance of such “primary process” thinking in our patients and experimental subjects, and also in ourselves, whenever the occasion is *appropriate*. The existence of alternatives — Mentalistic *or* Mechanistic — is also potentially very useful; as it offers a means for a pragmatic switching from one to the other, as in Ashby’s homeostat. However it will generally be best to at least have the option of using a more precise model, and we will take it that this must be one of the “Physiological” sort. The question then becomes one of whether we can translate all the important features of our approximation-models into the new reductionist framework, at least in principle. If we can, then we have the makings of a “frontal attack” on the problem in question. If not, then we may have to persevere with re-formulations of the approximation-models and perhaps also conduct research into any proposed new basic substrate — until such a cross-interpretation does become possible. (The Hegelian concepts of thesis, antithesis, and synthesis might profitably be discussed in the same terms also).

233

It is perhaps necessary here to refer again briefly to the supposed inadmissibility of trying to validate a theory by testing the internal consistency of its consequences rather than concentrating on its “observable” predictions; (Traill, 1976e; also Chapters A2 and C1, above). It is often said that J. B. Watson (1919, 1928, <233> 1931; Watson and McDougall, 1928) was the father of this traditional behaviourist view; and his pronouncements certainly constitute a strong advocacy of this position. Thus (1928, page 7):-

234

“Behaviorism’s challenge to introspective psychology was: ‘You say there is such a thing as consciousness, that consciousness goes on in you — then prove it [experimentally]. You say that you have sensations, perceptions, and images — then demonstrate them as other sciences demonstrate their facts’.”

Or, on page 3 of the same work:-

“Behaviorism thus leaves out speculations. You’ll find in it no references to the intangibles — the unknown and the unknowable ‘psychic entities’.”

However a careful reading of his discussion suggests that his main complaint against Freudian and introspective psychology was that they seemed to him to be using a thinly-disguised form of Cartesian dualism, involving a non-scientific spiritual “soul”, (ibid., pp 93-97): a “Mentalistic” concept in Hyland’s sense, which *might* after all turn out to be compatible with a *scientific* “Physiological” formulation, if the ideas of the present work happen to be reasonably correct.

Anyhow, if this point could be cleared up, the remainder of his case in support of publicly observable experiments might arguably be re-interpreted as a support for whatever could be used with most precision — so as to minimize the intrusion of ill-structured concepts into the current corpus of scientific belief. In the 1914-1930 period there was a good case for identifying this criterion with a support for a sober experimental approach, but it is conceivable that the present-day preoccupations with obscure statistical interpretations of experiments *now show little advance in concept-precision* in any meaningful sense, while structural theories based on the fairly precise elements of physiology, biochemistry, ultra-micro anatomy, and physics, *can now claim to hold the initiative in the precision-game*. However it would seem to be unprofitable to

indulge in a controversy<234> over the relative merits of these two approaches. Both are apparently necessary, and each will have its successes or otherwise, according to the current overall problem.

235

What then can either approach do to solve such perennial imponderables as: consciousness, attention, “mental energy”, personal identity, morale, or the poorly structured concepts of Freudian theory such as ego and superego? To Watson (1928) such questions about supposedly-supernatural abstractions could be nothing but meaningless: “If the behaviorists are right ... then there can be no such thing as consciousness or its substratum, the unconscious.” There is some suggestion that at one time he may have taken a more moderate view, though he himself claimed to have tempered his views in the interests of expediency in the early days; anyhow McDougall (1923/1931)<sup>47</sup> cites him as saying:-

“What has been called experience or consciousness may occur or exist for all I know or care. But I am not interested in it. I am concerned only to understand human behaviour. I know all behaviour is mechanistically determined by reflex processes; let me get on with the study of ‘conditioned reflexes’.”

Ashby (1960) also disclaims any insights or involvement on such issues. So should we be content to leave these concepts as vague impressions or permanent metaphysical intangibles? Of course, perhaps in the end some of them will defeat us — maybe even permanently. However, whenever a new way of looking at the mind/brain should happen to arise, then it would seem sensible to ask whether it will<235> shed any light on the old imponderables. The present theory does seem to offer a new perspective of this sort, so we may reasonably feel that any attempt to apply it to concepts like *morale* or *consciousness* will at least be instructive and thought-provoking, even if it is not correct in itself. But any actual success should have immediate application in explaining psycho-pathology.

236

## C6.2 Consolidating the functional principles of the current model — constraints and hierarchies

Broadly speaking, the task of the brain is to obtain and maintain an *organized and readily-accessible* model of the *more important* features of the organism’s environment. The whole purpose of any utilitarian model seems to be that it can be consulted rapidly, repeatedly, and with minimal effort or disruption during use; and this rather implies that appropriate parts of the model should be robust in the face of “interrogation” — and that the “referencing system” should be reasonably efficient, with an emphasis on building up “extensive” methods of set-formation rather than exclusive reliance on implicit sets using “intensive” methods alone. (Similarly, if a largish company is to be able to act promptly, its records should be filed and re-filed; and not just left in one large box even though each record might be clearly labelled. Moreover, these records should not easily fall to bits in the normal course of the retrieval of their information).

One might ask the innocent-looking question: “Why confine ourselves only to the modelling of the more important features of reality? — Why not aspire to ever-greater precision, and ultimately complete precision?” The latter extreme case of complete precision can be promptly dismissed due to the impossibility of rigourously modelling oneself, or of rigourously excluding oneself from any system of practical interest; (Landsberg and Evans, 1970). Other answers<236> of more immediate relevance will however also entail practical problems:- how to *obtain* detailed information about the environment without destroying it in the process; and how to

237

<sup>47</sup> McDougall alleges that this is from Watson (1919), but I have been unable to trace it there; nor have I found it in the third edition. Moreover I have not found so tolerant a statement in Watson’s other principal works on the subject (1928, 1931), nor in the debate between these two writers (Watson and McDougall, 1928). So perhaps it comes from one of Watson’s earlier writings, of about 1912. <235>

actually *build and operate* any nearly-all-embracing model — given that we must only use material media for the purpose. These outline arguments, or the latter ones at least, look suspiciously like re-formulations of the “indeterminacy principle” of physics and its counterpart in biology, (Elsasser, 1958, 1961); but here the trade-off is between rigour of the *detail* portrayed, and *robustness* in the model — e.g. the real system itself is naturally correct in every detail, but maximally vulnerable or unyielding to interrogation, and so a poor “model” of itself in our present sense, unless it is naturally robust.

For the environment, robustness may be interpreted as being *constraint* in the number of conceivable configurations or “laws”; and as Ashby (1956) points out, we can usually take advantage of any such constraint. Elsasser too makes much the same point when he describes physics as the study of systems with many identical and expendable members, and indicates the relative simplicity of elucidating the properties of such systems. Anyhow, we do not have to look very far to find considerable amounts of constraint in the environment — notably among material solid objects, but also for plastic, breakable, and liquid configurations; and then also for the behaviour of our fellow human-beings, even if their constraints are more loose and capricious than those of the “physical” phenomena.

As long as the perceptual environment shows any tendency towards permanent distinctions or boundaries, then we will have the basic essentials for an adaptive responder; but actual environments are particularly likely to produce some quite sharp distinctions ready for exploitation — even if they are only boundaries between solids, liquids, or gases; (at “biological” temperatures, at least). Such <237> toeholds on reality can offer a basis for the evolution of primitive creatures with only an initial  $M^{-1}L$  reflex capability, possibly restricted to “unsharp” discrimination of chemotactic gradients or concentrations. But note that the very existence of such evolved reflex-patterns constitutes a simple *model* of the properties of the environment, a model which would have evolved differently if the properties of the environment had been different. Moreover such a model would presumably be the prototype for subsequent modelling of pleasure/pain distinctions — a basic  $M^{-1}L$  attribute on which all subsequent model-building will eventually be predicated.

It seems reasonable to assume that, other things being equal, the most efficient type of model will be one which most faithfully reflects the same structural constraints as the outside reality which it purports to represent. After all, any departure from this will represent a departure from truth; and on the whole this will usually mean a loss in adaptability — though it may work well as long as the environment does not actually show its full repertoire of potential phenomena but continues to display an (ultimately spurious) appearance of surplus constraint. Anyhow, insofar as the model is likely to reflect outside structure, it will be instructive to look carefully at the constraints and regularities inherent in the observable environment (including the environment of ideas and culture, where humans are involved). Hopefully this will shed some light on the type of structure likely to develop in our mental models, and hence help to explain important aspects of our mental processing.

Rather than continuing to develop the theme of analysing the *manifest* properties of physical systems (started three paragraphs ago) and unfolding the hierarchical nature of these constraints, as already done above in Chapter A3, it would instead be more assimilable to the adult point of view to start at the other end of the process and <238> work backwards *from* the abstractions of which adults are consciously aware. In fact abstract concepts seem to fall naturally into two broad categories which we will look at separately. There is the logical, mathematical, hard-science tradition; but there is also the rather more nebulous worldly-wise area of business, politics, the novel, and subtle interpersonal relationships — involving phenomena which are (as yet) too complex or lacking in discernible regularity for us to be able to cope *unless* we use gross approximations in our models, with all the dangers of mutual incompatibility and departures from



truth which this entails. (One might also argue in favour of yet other categories of abstract concepts, such as mystical “inner experience”; however these will not be discussed here).

Western culture seems to endow formal mathematical systems, including logic, with some sort of mystical transcendental power — a privileged gateway to at least some of the ultimate undoubted truths (episteme) of nature. While there is some basis to such a claim, it cannot stand up in any absolute sense; and this work will treat all these mathematical systems as being, epistemologically speaking, no more than particularly successful types of mental model which are culturally transmittable with minimal difficulty because of the robustness of the basic schemata. This robustness and their general usefulness arises directly from the policy of selecting and refining such systems on the basis of how well they display internal closure among their basic operations. (In this sense then, there is nothing mystical about their properties — they have been inbuilt in much the same sort of way as survival-techniques are built into evolving living organisms). The practical value of such systems arises whenever they can be matched to physical phenomena — thus demonstrating the internal closure of our ideas about the latter, and so tending to validate them in this internal sense. <239>

However, thanks to the work of Inhelder, Piaget, and their colleagues, it has by now become apparent that there is also an important pragmatic (external) basis to these abstract concepts. In practice, natural physical phenomena are constrained to certain types of behaviour, and these constraints<sup>48</sup> are seized upon for the development of mental models. We have seen above that gross textural/chemotactic/etc. features may become reflected at the crude genetic  $M^{-1}L$  level; and the concepts involved in solid geometrical objects were explained as evolving from experience with reality, resulting in the  $M^0L$  level; (Part A, above; Traill, 1975b). By now the organism will be dealing with internal representations presumably, and this process may continue on from this less-obvious abstraction into the patently abstract. Thus during the Concrete Operations period, there will develop a mental model of the constraints inherent in the physical manipulation of the solid physical objects (such as rules of multiplication and set-closure), giving us our  $M^1L$  level. In so far as these rules for different individual operations (as represented in internal intensive coding) can become generalized (sorted into extensively defined sets), then we will have various separate types of algebra, including logic — and hence we will have reached the  $M^2L$  level. Similarly, any further generalization into an algebra of algebras will presumably give us an  $M^3L$  level.

Here we have been covering old ground. But the new point to be made here is to emphasize that our ability to build up such a hierarchy of abstractions is largely though not entirely governed by the real hierarchies of constraints which happen to be present in our<240> external physical environment; and consequently that our adult mental model will presumably tend to reflect the same “logical” structure as the environment which it purports to represent. A corollary of this is that if we happened to have been brought up in a world with different-but-structured physical laws, then we would stand a good chance of adapting to them also — though this might well depend on the sizes of the logical leaps between one set of regularities and the next, more generalized, set of regularities. This thought leads us directly to the problems of the more nebulous “worldly-wise” type of learning task:-

One of the most distinctive features about the *arts and humanities* is the important position they give to *egocentric and ethnocentric* considerations.

<sup>48</sup> These notably include mathematical-group properties. I suspect that we might well be able to interpret these much further by a cybernetic analysis using a deeper reductionist interpretation; but that is a matter for discussion in the context of physics, and we will not go into it here. <240>

(By contrast, the hard sciences go out of their way to *decentre* their concepts. This has its admirable side, leading to such concepts as the heliocentric solar system, and relativity; but this does seem to encourage the risky idea that one's subjects or patients or acquaintances "should" constantly be objective and detached on all or most matters. More importantly in the present context, it encourages us to forget or overlook the egocentric origins of our supposedly transcendental ideas on mathematics and the physical world; and this is sometimes suggested by the scant attention given to source-references in such disciplines. The danger in this forgetting of origins is that we will remain unaware of any corners that may have been cut in the past, to answer specific questions, but which cannot be legitimately cut for new questions which arise later on. I would suggest then that much<sup>49</sup> of our claim to objectivity in the hard sciences is, strictly speaking, spurious — though excusable for the <241> "trivial cases" studied in the hard sciences; but if we are to progress significantly into the "soft sciences" in any formalized way, then we must inevitably go through the tedious task of uncovering the short-cuts and the *untidy* aspects of epistemology which these short-cuts have served to circumvent).

242

In discussing any egocentric activity, some view must be taken of the organism's self-concept; for as soon as it gets as far as conceptualizing objects as such, its own body will figure prominently among the objects considered. But even before that, at the Sensori-Motor stage, there will be developing sets of distinctions between "what can or cannot be influenced by my actions", and between what is subject to sensation and what is not; and here it is not necessary to conceptualize actual objects in any coherent sense. From this self-concept or ego, we may expect the differentiation of "those objects which are close to me, but are not fully me, and are rather less controllable" — giving the imago concepts of parents and other closely associated persons, who may ultimately come to embody societal values thus providing a basis for superego concepts.

[Many of the issues raised here were later discussed in greater depth (Traill, 2000, Part I), now available online as [www.ondwelle.com/BK1\\_V28.PDF](http://www.ondwelle.com/BK1_V28.PDF) or in print as "*Physics and Philosophy of the Mind*", Ondwelle Publications: Melbourne. — RRT, 2006]

### C6.3 On modelling Attention, Ego, Consciousness, and Superego

Let us deal with these various concepts in turn, in chronological order this time. We may start by considering the nature of *attention*. Following Freud, this *can* be thought of as a room into which only a limited number of mental-preoccupations can fit at any one time (Section A1.4, above); but as a physiological model this is not really very credible, and we might do better to postulate a competitive energizing process such as has been demonstrated in the mutual inhibition in the retina (Teitelbaum, 1967; after Barlow, Fitzhugh, and Kuffler, 1957). This would involve a negative cross-feed of some sort — conceivably a primitive competition for scarce resources, though it is also possible that inhibition signal-targets could be <242> specific, and perhaps even learned. (The ethological concept of displacement activity as a substitute for *both* of two mutually incompatible potential activities, seems to suggest specific inhibitions — though this could be attributed, somewhat improbably, to *local* scarcity of resources). Anyhow we shall tentatively assume that the phenomenon is *largely* one of emission of specific inhibiting signals which may be more, or less, generally effective — depending on the distribution of "labels" sensitive to such signals. (The potential usefulness of this postulated mechanism for explaining the Freudian concept of "repression" will perhaps be apparent at this stage).

243

Next we must look more closely at the likely methods for building up the *self-concept*. To this end, it seems helpful to consider the nature of motivation in general — leading up to the issue of what it is that provides the motivation for an individual to go to the trouble of forming a self-

<sup>49</sup> In fact physicists seem to have partially escaped from this trap by recognizing the inevitable disturbing role of the active observer, and the principle of indeterminacy. <241>

concept. The usual laboratory type of positive or negative reinforcement tends to be of the simple physiologically-obvious type: shock or food-reward, “stick or carrot”; and the effect of these unconditioned stimuli is initially to produce genetically-determined responses which are likely to protect or maintain the individual or his kin. The setting up of such genetic stereotypes, by orthodox natural selection, may be regarded as a sort of trivial “motivation” of trial-and-error survival; and we may also identify it with the  $M^{-1}L$  level, not requiring any sort of brain, and just as much a characteristic of a plant as of an animal. By contrast, the simple “stick or carrot” learning will occur within the one continuing individual — though the present theory maintains that there will be a *captive* natural-selection process going on within some form of nervous system, and probably using fundamentally similar genetic-type mutation processes. Anyhow, we shall identify this type<243> of activity as being “Sensori-Motor” and as taking place at the  $M^0L$  level.

244

By now we have got past the mere issue of survival (a sort of “pleasure or pain” for the species), so we have reached the normal “literal” meaning of pain and “erotic” pleasure (in the Freudian sense of bodily sensation). It seems reasonable to suppose that it is those scheme-elements which are being attended to (and hence in communication with some signal pathway) that become associated with any feelings of pleasure or pain at about that time. This association, by “tagging” or by some other means of discrimination, would provide a ready explanation for approach or avoidance tendencies and hence for “motivation” in the formal sense. However, this in itself does not explain actual feelings (as opposed perhaps, to the outward “emotional” behaviour of a neonate or sensori-motor animal). It seems difficult to imagine feelings without consciousness; and for the want of any better guidance, it will be assumed here that consciousness must await some sort of self-concept, the very phenomenon which we are currently leading up to — as a somewhat *later* development.

Now we may recall from Chapter C5 that such elements were supposed to become “listed” in extensive sets of apparently related part-images of the outside world (perhaps because they gave similar parallax “responses” to a move of the head, or because of some other intensive property which they all happened to have in common). Furthermore, it was supposed that there was a propensity for the individual to selectively save those versions or ensembles of such lists which had “mathematical-group” properties or a tendency towards them — indicating a degree of *internal* closure in addition to the pragmatic pleasure/pain external closure encountered earlier. In this way, it was suggested, the individual re-constructs *by himself* a potentially realistic mental model for each important distinguishable object in his environment.<244> At this stage, (if we may use one of Piaget’s examples), he probably cannot tell *slug A* from *slug B*, or understand the concept of *slugs in general*, (Baldwin, 1967, p 238); but this will apparently not invalidate our next two points, and the deficiency will, in any case, be made good in the following Concrete Operations period — see Table C5.4/1, and also Gambling and Traill (1977).

245

The first thing to notice in this is the postulated preference for internal closure. Another way of interpreting such a phenomenon would be to say that:- the *formation* of internal-closure gives “pleasure” to the individual and its *disruption* gives “pain”. Clearly this is a new type of pleasure/pain, which might not be felt so consciously (by those having consciousness), but it might nevertheless be just as real. Presumably its origin would also be hereditary, though possibly in a trivial orthomaturational way, since we might reasonably expect *any* structurable dynamic medium to generate *some* stable configurations with group properties, under some conditions at least, (e.g. Goel *et al.*, 1970; Goel and Leith, 1970; Leith and Goel, 1971). Indeed, as we saw at the end of the previous section, this is the ultimate justification for such a propensity:- there is an excellent chance that the outside environment will ultimately have similar properties, in one form or another. If inside and outside both tend to share the same basic property, then the self-organized modelling process appears feasible; otherwise it is difficult to see how

life could exist with any substantial degree of complexity — or even, perhaps, how it could exist at all!

The second point, also introduced in the previous section, is that we can now start to explain the self-concept as a special augmented type of object-concept. From a sensory point of view, our vantage point of our own bodies is certainly unique, not only regarding vision and the various tactile senses, but also in <245> audition and olfaction. Perhaps even more important though, it is open for us to discover that hands, feet, and mouths are much more likely to move more-or-less in accordance with our wishes — while the behaviour, if any, of other objects in our environment will generally be much more capricious. True, the mother-figure in our environment might be over-responsive to our whim, possibly leading to a rather over-broad concept of where our self-boundary should be placed; but even then there will be a readily discernible difference in time-lag, reliability, and scope for misinterpretation — though of course the neurotic's perceptual process may “choose” to overlook such differences.

246

So, without needing to labour the point, it seems reasonable to suppose that initially one's self-concept is just another object-concept, derived in the usual way; but that its unique associations and properties ensure that it very rapidly comes to dominate the mental-object scene — especially in view of its inescapable omnipresence. (We may notice, in passing, that this is another example of ortho-maturation:- a development implicit or “expected” by the genetic code, but not actually coded into it). Thus then we appear to have the makings of a *personal identity* or *ego*, and we may provisionally take these terms as synonymous with *self-concept*, though we might wish later to endow the former terms with properties arising from further development.

At what stage then does the ego arise? Judging by the postulated evolution of other object concepts, we might say that during the sensori-motor (or oral) stage, it becomes built up as a non-integrated ensemble of ego-parts: “my hand”, “my mouth”, and so on. In the normal course of events we would expect such parts to become integrated as sets and groups, early in the following Concrete Operations<sup>50</sup> period — <246> a development which may readily be associated with the wilful acts of autonomy over environmental influences attributed to the *anal* stage in development (according to the Freudian formulation). In view of the presumed pre-eminence of this ego schema and its antecedents, we might expect this particular set-and-group formation to be the first substantial sign of the emergence of group-formation in general. So while we might describe such a development as a Concrete Operations (or **M<sup>1</sup>L**) activity, we need not be surprised if it actually occurs in what is still a predominantly Sensori-Motor period. Such overlaps for different aspects of development are, after all, part of the Piagetian description.

247

So now we may turn to the thorny issue of *consciousness*. We can at least start by postulating two pre-conditions for consciousness:- attention, and self-concept. If we stop attending to something, then it slips from consciousness; and partial attention implies partial consciousness of the thing concerned. If we are unconscious, then we are not attending to anything. If we are dreaming, then we may be “unconscious” in behaviourist terms, but we are actually attending to internal schemata, and we ourselves *are* conscious in this sense.

But it might well be argued that a normal computer can and does “attend” very closely to its “senses” and to its motor activities; and it might even be said to switch its attention from one task to another when it is operating in a time-sharing mode (as is usual for large computers these days). Yet one would scarcely claim that such attention, on its own, would constitute consciousness; and the particular shortcoming which we will deal with here, is its lack of any flexible self-concept of the type we have been considering.

<sup>50</sup> in the wider sense which includes the “Pre-operations” sub-period. <246>

These two conditions may well be *necessary* for consciousness to occur, but are they likely to be sufficient? After all, the concept of consciousness is closely bound up with age-old concepts of *sentience*<247> and *soul*<sup>51</sup>; and at first sight the proposed physiological/mechanistic organizations for attention and self-concept are not immediately obvious as the likely bearers of sentience, nor of soul. It may indeed be the case that other pre-requisites will become obvious at a later date; but meanwhile it will at least set the stage if we look for potential makings of sentience and/or soul within such a mechanistic-physiological organization as the present one.

248

If we look more closely at sentience, it does seem to have a lot to do with pleasure/pain at a *symbolic* level — which, in the present context, may be interpreted as pleasure/pain relating to states of internal closure at the  $M^1L$  level. (In later development, the  $M^2L$  level might also become involved; but if consciousness can occur here before it arises, then clearly the  $M^2L$  phenomena cannot be essential ingredients). Perhaps all such symbolic pleasure/pain will involve the state of closure of the self-concept in some way; anyhow we may at least expect this to be true of the more powerful instances — in which sentience is most in evidence. Take, for instance, those “very human” traits of sentimental attachment to an object of some sort. It seems reasonable to assume that the internal schema associated with such an object is bound up in some way within the group-like structure which constitutes the person’s ego. Consequently any loss of such an object (if it then results in a change in the internal schema) will be likely to upset the stability of the person’s self-concept or ego; and, on the other hand, any refusal to accept the objective change by clinging to the old schema, will result in a mental drift away from reality. Of course Freud makes very much the same point in his “Mourning and Melancholia”, and his term<248> “cathexis” may be interpreted here as meaning “included within the group-like structure of the ego”.

249

Thus there is a *prima facie* case for agreeing to the proposition that the necessary and sufficient conditions for sentience (and presumably soul and consciousness as well) are simply those suggested above:- Attention and Self-concept<sup>52</sup>. Provisionally then, we may accept this as a working hypothesis until some contrary argument or evidence leads us to re-consider the situation. We should bear in mind however, that any explanation of consciousness will probably appear at its least credible when one tries to apply it to one’s own consciousness:-

“*Cogito ergo sum*” — “I think [= ‘I am conscious’?], therefore I am”. “Perhaps *your* consciousness is explicable mechanistically, but surely mine is somehow special and transcendental — and probably eternal also! After all, I am quite unique and special in a remarkable way. Surely my life at least has a supernatural basis?”

(On the other hand though, these very thoughts help to suggest the important egocentric role of the self-concept as a hopefully stable point of reference in group structures at the  $M^1L$  level).

The remaining task for this section is to be rather more specific about the concept of *superego*, than in its previous mentions in Section C6.2 and in Traill (1975c). In the latter paper, superego was seen as “one-or-more schema (imago) embodying the perceived properties of another ‘person’.” To which the comment was added that this structure might provisionally be thought of as occurring at the  $M^2L$  level rather than the  $M^1L$  level of the ego; (though the terminology used was a little different). On second thoughts though, it seems more likely that superego constructs will be on the same level as the ego (i.e.  $M^1L$ ) — and not in the  $M^2L$  realm of Formal Operations and<249> Secondary Process Thinking. (Of course it might later be appropriate to consider whether there might not be *another level* in between these two, especially

250

<sup>51</sup> Lest there should be any doubt, I am not supporting any type of dualism here. Any “soul” will be supposed to have an ultimate physical embodiment — like that envisaged for any other mental phenomenon. <248>

<sup>52</sup> provided it is based on pleasure/pain motivation toward internal closure, as described above. <249>

if this would resolve some subsequent paradox. But for the moment, we will assume that this is not the case). The essence of the “debate” is this:- On the one hand we have several reasons for expecting the superego to make its appearance *after* the self-concept type of ego which we have been considering — which suggests the possibility of its being characteristic of a later stage, but by no means establishes this convincingly. Then there is the apparent ability of the superego to *control* the ego, and this seems to imply a higher echelon within the  $M^1L$  hierarchical organization; though against this, it will shortly be argued that this sort of control does not always operate in a downward direction within the  $M^1L$  hierarchy — and that the control must sometimes be upward or sideways!<sup>53</sup>

On the other hand though, if one’s self-concept is essentially an object-concept, and if the superego is also based on object-concepts (“perceived properties of another ‘person’”), then it is difficult to see either of them as belonging initially to any level higher than  $M^1L$  (which entails power over objects); and indeed we might expect the basic “objectness” of self *and* parent-figure to lie in the  $M^0L$  level — in both cases. Moreover it seems unlikely that either structure has any strong affiliation with  $M^2L$  constructs, because in neither case are they directly and reliably amenable to the rational logic of the  $M^2L$  level of Formal Operations. Then again, if the super-ego differentiates from the ego in a gradual way without any discrete qualitative jumps, then it seems likely that it will still be found within the same functional medium as the ego. Anyhow this is the view which will be taken here, and maintained until a better contrary argument crops up.

But how is it that these parental imagos are supposed to modify <250> the ego’s activity? — What are the likely mechanisms? Well, at least it makes reasonable sense if we use the object-building conceptualization, and consider that the individual will usually be faced with apparent rival claims on his internal-closure tendencies. Of these, self-concept is undoubtedly the most important; but it is rivalled by other closely related configurations:- self-plus-other-people-closely-involved-with-me, mother, father, mother-father, animate things, and other such permutations. Different sets of haphazard experience or context will favour some such world-views for the moment, and discourage others — until the external situation changes yet again. But on the whole this will tend to yield a reasonably balanced view of reality for that individual, in the long run. Of course the important lesson to be learned here is that *society* (in one personified form or another) is a vital part of reality, of comparable importance to the *self*; and that flouting of society’s norms is likely to be painful to either one’s sense-receptors, or to one’s ego-support through  $M^0L$  or  $M^1L$  retribution — “painfully” attacking one’s internal closure at these levels.

In the longer term then, these superego/social group-like structures will presumably tend to shape their ego counterparts, and vice versa — each providing some internal constraints on the stability of the closure-patterns of the other. We may nevertheless accept the Freudian idea that the two start off as the same structure set, and that it is only in the light of further experience with the world that alternative closure-structured hypotheses evolve in favour of a differentiation of this sort. Such differentiation will presumably run counter to the preference for maximum closure — apparently expressed by the Eastern ideal of “Nirvana”, a universal oneness which incorporates the self in a strifeless eternity — but such a world-view does not accord very well with the realities of an Earthly <251> mortal world, so countervailing support for differentiation will build up as the infant becomes increasingly confronted with the evidence that “Mummy is not just part of me“! Paradoxically, some of this evidence may be seen in retrospect to be

<sup>53</sup> See also the later discussion and diagram of “Democratic pseudo-hierarchies” in Traill (1999, §8.3(5), p64) — now available online as [www.ondwelle.com/BK0\\_MU6.PDF](http://www.ondwelle.com/BK0_MU6.PDF) and in print as “*Mind and Micro-Mechanism*”, Ondwelle Publications: Melbourne. — RRT, 2006].

logically spurious (just as many scientific ideas or inventions had their initiative in concepts which were not in themselves correct); thus it has been suggested that the main incentive for the differentiation of “other” from “self” is the difficulty in accepting “bad” and “painful” into the concept of self — so some other scapegoat entity must be found, and this criterion of goodness-or-badness is therefore the original pseudo-definition for self-versus-other; (Fenichel, 1946).

[In passing, we may note that this trend toward self/other distinction can, in a sense, be induced to take a useful step back *into reverse* by the unfolding of genetic developments. The significant emergence of any new erogenous zone or mode will inevitably throw a new  $M^{-1}L$  (id) factor into the situation; and in particular, the advent of genital sexual arousal will predispose the individual toward a selective re-extension of ego as an amalgam with the concept of the loved one, into a more generalized group-like structure. Indeed such a psychological accompaniment to procreation would seem to be essential in humans if the resulting children are to encounter the ego-forming environment which the genetic code takes for granted — as an orthomaturational extra].

There are other useful ways of conceptualizing such schisms in mental structures. One notable approach is the theory of “Cognitive Dissonance” promoted by Leon Festinger and others (see the anthology edited by Fishbein, 1967); and criticized, on purist-experimentalist lines, by Chapanis and Chapanis (1964). The essential point here is that three propositions (A, B, and C) are each considered in relation to the other two. To put it briefly (and in the terminology of our<252> present discussion), there must be mutual consistency, i.e. internal closure right round the triangular path — *or else* there will be a strong motivation to change one or other of the propositions; or to escape the “dissonance” in some other way.

The theory predicts, quite reasonably, that a “negative attitude” such as we might expect C to be in Figure C6.3/1, will induce a similar negative attitude in either A (differentiating self from mother, in this case) *or* in B (dissociating pain from both, and presumably projecting it onto some other conceptual object). Both these solutions imply a schism of one would-be group structure into two separate structures. Such differentiations are necessary if we are to develop an adaptive model of reality — *and* they depend on there being a detectable amount of differentiation in our perceivable environment; otherwise our picture of reality would remain as one undifferentiated mass — a trivial situation in which the chosen solution is to make C into a “positive attitude”, thus embracing pain! (This solution is probably not feasible in this case, unless the genetic  $M^{-1}L$  nature of pain changes, or the “pain” is itself due to some other lack of closure, *or else* a higher  $M^1L$  level intervenes and so constitutes a case of masochism (Fenichel, 1946, pp 73-74)).

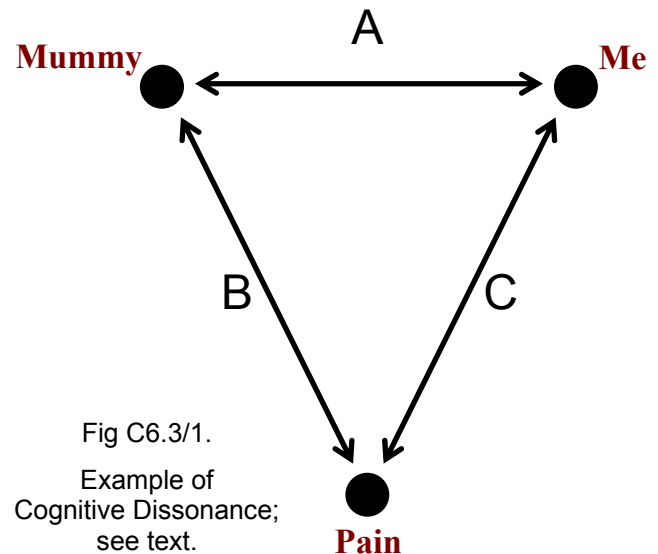

One trouble with this simple model is that real situations will usually involve more than three elements, so that the web of affiliations<253> between them will be much more complex, and indeed the simple triangle-based rules used above will not serve us any more until they have been extended. Such extension is best conceptualized by some sort of matrix-table of connections, and one such formulation is given by Abelson and Rosenberg (1958;— in Fishbein, 1967), a formulation which appears to work for the data which these authors provide — though we may doubt its general applicability in the form given by them:- a specific algorithm which amounts to

a cluster-analysis technique and which gives non-believable results in some apparently applicable hypothetical examples. Of course, in a sense, the whole purpose of such biological attempts at meaningful differentiation *is* to perform cluster-analysis; but this is scarcely a matter for algorithms in the normal computer-oriented sense, and it should moreover be viewed as a potentially continuing process — open to feedback and new evidence, as well as being probably performed by some self-organizing process which will also be sensitive to feedback. By contrast, the “Repertory Grid” measurement techniques devised by George Kelly (1955) would appear to do better justice to gauging what the important elements are (in the mind of the individual concerned), and how they should be clustered. To a considerable extent, these analyses can detect blockages in the formation of adaptive differentiations, and these may lead to solutions; but their proper use depends on feeding the relevant tentative findings back to the individual himself, (presumably at the  $M^2L$  level!)

The more biologically sensitive aspects of such modelling would seem to be quite compatible with the micro-element theory and its concepts of internal closure which we have been discussing. The major difference of emphasis is obviously in the fineness-of-resolution and the concomitant difference in measurability. In practice we will also expect the clinical/behavioural conceptualizations to recognize<254> a degree of “fuzziness” in the subject’s mental constructs especially in his attitudes and associations, though also in his mental models of objects. (On the other hand, in the realm of the perhaps-unobservable, we can envisage a fairly precise discrete structure for elements at the molecular level, with the fuzziness arising as statistical consequences of populations of these discrete phenomena). Rather more significantly however, I am less certain that any actually-existing  $M^1L$  structure will necessarily come to be reflected in any cluster-analysis technique as currently administered, though I fancy that the Repertory Grid technique is flexible enough to do so if it is administered by someone who is sensitive to the possible importance of non-standard entities intruding into the “normal” domain of experimental study, *from  $M^{-1}L$  or  $M^2L$  levels*. Indeed perhaps the method has already picked up such phenomena. Moreover, some types of hierarchical or lattice structure may not necessarily lend themselves readily to expression and analysis via orthodox cluster-analysis matrices. If this is the case, then the main need is to *become aware* of the previously unsuspected structural complications of the subject’s thought-affiliations.

But let us return to our specific case of concept-differentiation:- the nature of the superego, and its distinction from the ego. We have already identified the ego as being the individual’s self-concept, or at least those aspects of it which are pertinent to consciousness or to the control of one’s activities. Similarly superego is usually regarded as being a parent-figure personification of some aspect of society’s demands on the individual — as seen by him; and subsidiary “parasite superegos” of hypnosis or war-neurosis serve much the same role, though in a more ephemeral way (Fenichel, 1946, p 125). But by what mechanical-or-physiological means could such structures exercise their influence over the ego — bearing in mind that in some<255> cases this control seems to become dictatorial in its strength?

In natural conditions, surviving primate infants will always have considerable contact with one or more parent figures who will, to a greater or lesser degree, generate schemata with sufficient resemblance to their own characteristics for them to be able to “graft” these conceptualizations onto their own fragmentary self-image scheme-like structures — hopefully resulting eventually in a reasonably coherent whole which may now be identified as the self-image or ego. Even at the basic object-level ( $M^0L$ ) this is probably indispensable for any orthomaturational development of a self-concept; and the mechanism might fairly be explained as generating potentially-useful (though unstable) scheme-like structures as images of the examples presented — structures which are thus available for incorporation into the “jigsaw” process of building up a credible group-like stable structure to represent the self. It may reasonably be supposed that



without a good supply of such part-formed pieces as “hints” available for introjection, the task of satisfactorily building up the “jigsaw” pattern of self would be virtually impossible. (Such a mirror-like function of Mother-Child interaction shows clearly in work such as that done in Edinburgh: Trevarthen (1974, 1975), and Maratos (1973, 1974)).

One consequence of this procedure is that the infant presumably “builds his house out of local materials”; that is, his self-structure will contain components whose composition is influenced by any local peculiarities in the environment which he has happened to have experienced. If we confine our attention to the more object-centred experiences of the  $M^0L$  level, such variations are not likely to be very extensive — after all, geometrical and physical properties do not vary vastly from one place to another, even if there are some significant differences for such things as facial configurations. <256> However as soon as we advance into the complexities of social environments, there will clearly be very great local differences. Consequently the crucial  $M^1L$  aspect of the self-concepts might well be very considerably affected by the nature of the scheme-like fragments which become incorporated into the structure of the ego at this stage. This then is almost certainly a vital feature in personality formation (presumably in combination with *genetic* raw-materials and “tools”); and it is undoubtedly significant that this coincides with Freud’s “Anal Stage” with the infant’s exercise of his powers of choosing to give — or choosing to withhold.

257

But how does this explain the superego’s apparent tendency to control the ego? Surely there must be more to it than a mere sharing of common scheme-like fragments? Well, it would seem likely that these fragments will often maintain viable connections with more than one schema-structure, and this will presumably mean that we must face the problem of trying to attain closure simultaneously in two separate-but-communicating sets. (Essentially this is the same problem as the case of Cognitive Dissonance problems in which there are more than the simple triangle of three entities; and in fact no full solution may be possible). If simultaneous closure of the two sets *is* possible despite their need to “cooperate”, then well and good; but otherwise we must expect to see one set achieving closure at the expense of the other — or perhaps there will be deadlock, or oscillation between the two possibilities (suggestive of a manic-depressive condition perhaps?), or some other type of compartmentalization.

This discussion has been referring to the more macro ensembles such as schemata, and these are to be seen as being composed of coordinated *populations* of elements which we have taken to be linear molecules (such as RNA). At this stage it seems helpful to consider more closely just what might be happening at the molecular level —<257> this being basic to any physiological-mechaniatic understanding of the underlying processes. Let us start by considering the stabilizing

258

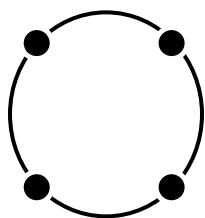

(a). Simple loop

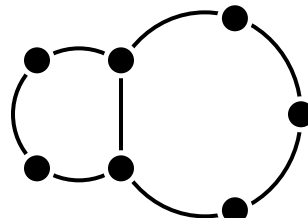

(b). Figure-of-eight

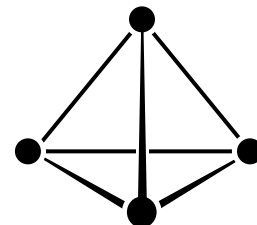

(b). Polyhedron

Figure C6.3/2. Group-like corroboration around the topological loops inherent within the supposed intensive-reference patterns between members of a developing physical set. Looking from left to right, the configurations show increasing degrees of mutual support, presumably adding to the stability of the topology.

influences on a simple “set” configuration (see Sections C2.3 and C2.4, above). Initially our extensive set is presumed to have been formed on the basis of some arbitrary intensive criterion. As such, it will only be “on probation” — with some sort of precarious metastability until such time as it might gain extra stability from elsewhere; otherwise it will simply be dissolved as a “Darwinian failure”. One way of achieving this extra stability was seen as being the acquisition of group-like properties: simple closure around a “loop” in its own membership-references — or better still, by additional mutual corroboration with the loops of other sets; see Figure C6.3/2.

It is not clear precisely how this would be likely to work out. Indeed it would not be altogether surprising if the actual details were “messy and pluralistic” from the viewpoint of an observer who was looking for the sort of order he would find in a crystal lattice. It should, of course, be recalled that we are considering *communicational* networks, and that these are not necessarily the same as geometrical-physical considerations, despite anything that Figure C6.3/2 might suggest to the contrary. But must the different loops arise from <258> different sets (which then form an amalgam), or could they arise *ab initio* within the same original set? And are the entities, represented by dots in Figure C6.3/2, definite and distinguishable — or are they simply interchangeable exemplars, indistinguishable and diffusely distributed? There seems to be no compelling reason why these various possibilities could not all have some element of truth — in a “messy and pluralistic” way, and indeed the actual mix might well depend on the complexity of the structure to be depicted — simple structures evolving successfully by trial-and-error within the solitary set (and perhaps its exact replicas), while more complex structures would presumably require a more piecemeal approach (with or without the aid of higher  $M^{\text{PL}}$  levels).

259

(There are some interesting parallels here in the structure of various chemical substances *in bulk* — though it would be dangerous to read too much into such analogies. Ionic solutions, benzene derivatives with their conjugated double-bonds, and liquid crystals are cases in point).

Anyhow, the points which are important for our discussion arise here when we consider what is likely to follow if this sort of arrangement *applies to the  $M^{\text{PL}}$  structures* including ego and superego. For one thing, one’s parent-figure basis for the superego will certainly be too well established and corroborated for it just to dissolve away if it does not happen to fit at all into a coherent whole with the self-concept. It is even less conceivable that one’s self-concept could dissolve away under such circumstances — especially if we see it as the “gateway” to consciousness. Accordingly, if there is a serious incompatibility between the two, then one of the following courses would seem to be inevitable:-

- One might suppress the other (and this probably means “repress” in Freudian terms), either obstructing its external communication, or by using some sort of superior magnification of its own influence — probably by outnumbering the other in terms <259> of elemental units, or by incorporating into its schema some elements which are inherently more attention-promoting. There is some difficulty in seeing how this could work effectively *en masse* over a diffuse extended region, but it might well have some local importance.

260

- Another possible course is for one or both of the structures to accommodate its overall structure to the peculiarities of the other. Such structural changes are probably occurring arbitrarily in the elements all the time anyhow — as chance mutations. In these circumstances, there will be an encouragement for some mutations to proliferate so as to improve the overall closure (even at the expense of a more restricted type of closure), and this will *ipso facto* tend to reconcile the “demands” of ego and superego.

[▪ A third possibility might be “to do nothing” and to keep the self-concept apart from superego/social concepts. In so far as this is possible, it would probably amount to a dominance of the ego, denying the existence or relevance of social imagery. As such, it would appear to be a special case of the first possibility listed here; but it is perhaps worth noting that this seems very

close to Laing's (1960) suggestion concerning the development of at least some types of schizophrenia. Briefly the scenario runs something like this: "I deny the impossible and stupid demands which society makes on my ego, so I will re-draw my concept of reality, narrowing it down to schemata which are closer to my inner *real* self. But now I find that my ego is becoming atrophied through lack of external closure. I shall blame the outside world again, and draw my concept of reality yet closer so as to protect the purity of my real self. ..." — and so on, perhaps into catatonia].

Such concepts as *closure* and *differentiation* can probably only have a precise meaning when applied to small localized ensembles of discrete elements such as molecules; and even then we would probably<260> have to postulate that they exist in an artificially strict isolation. For such macro-oriented concepts as *ego* and *superego*, this limitation to structural definability will be even more applicable; and whether we like it or not, we will presumably just have to put up with it. Clearly such terms do make sense at the macro-level, and it seems likely from the above discussion that their discrete underpinnings at the micro-level can be plausibly postulated, if nothing else. Such limitations are by no means new. Any discipline concerned with large populations of discrete elements runs into the same problem: Physics and chemistry of fluid systems, and (arguably) the concept of socioeconomic classes, are cases in point. Of course we can find ways of handling such population concepts — appropriate to specific problems at least, even if we cannot arrive at an ideal generalized approach. (As examples of such ad hoc modelling we might cite Ashby's concentration on specially chosen configurations (1960), or the use of statistical mechanics for populations of particles or gas molecules in physics). There is no obvious reason why similar techniques should not be useful, in at least some contexts, for brain-systems if they can be adequately specified statistically and/or paradigmatically in this way; but in order to achieve sensible results in this approach, it will be more than usually necessary to be clear about what we are doing, and why we are doing it. (In such matters, other things being equal, it is probably more profitable to be specific — at the risk of being wrong — and then be on the look-out for evidence that might shed light on any errors implicit in the theoretical assumptions).

261

Anyhow, what can we now say about the ego and superego structures, and the nature of any dictatorial tendencies of one over the other? For one thing, we can start by casting doubt on the propriety of the "dictatorial"-power concept:- Joan of Arc may well have hallucinated<261> voices which commanded her to crown the Dauphin, but it is also possible that these hallucinations and their content arose as *secondary* consequences of her pre-existing world-view on social matters — probably involving parental imagos within her superego, but not necessarily *originating* as a capricious command from such a source. In the context of the present theory, it is more informative to think of superego "commands" as particular *socially-oriented* sets which are somewhat *lacking in closure* and yet, for historical reasons, they are also important *constituents in the closure-pattern of the ego*. Or, to put it another way, the attempts at closure (for a specific aspect of self-concept) runs into a conflict between (i) the more obvious aspects of *self* and their self-consistency, and (ii) self as a *social* being within the context of what one sees as facts and also the closure-requirements within one's immediate society.

262

Emphasis on (i), the non-social *self*, would seem to be characteristic of the man who will expend great efforts to make exhaustive coherent sense of his own self or his ideas, (Leonardo da Vinci, perhaps?); while emphasis on (ii), the *social* being, looks rather more like Dixon's (1976) authoritarian military commanders whose self-image largely rests on the continued favourable opinion of "father figures", and who will tend to put themselves and their armies in suicidal situations in an unconscious attempt to maintain this favourable opinion. However I see no inevitable reason why we should expect people to be consistent on such matters. Such emphasis, one way or another, could well be situation-specific or (more precisely) specific to the particular aspect of the self-image which is involved. In practice though, if one is brought up in an environment in which one aspect of one's self-concept is learned as being predominantly a matter

of social-approval, then there will probably be a similar learning-situation for other aspects of self as well. But this is<262> not inevitable, and we might well be aware of the possibility for exceptions such as might arise from a home/school dichotomy — or situation-specific attitudes exhibited by the parents. (Inconsistent behaviour by parents *within* a specific situation constitutes a rather different phenomenon, and will be discussed in Chapter C8 as being a probable schizogenic factor).

Another influence likely to enhance the consistency of a person's view across different aspects of self-concept will presumably arise at the  $M^2L$  level. Here the person is likely to realize, intellectually, that he is acting inconsistently; whereupon he may or may not feel strongly enough about it to try to remedy the situation. He might seek out situations which promote one attitude or the other, (this could be done unconsciously and perhaps entail Freudian repressions); or he might consciously seek enlightenment or other help. There is however no guarantee that such endeavours will succeed.

We may summarize the situation of the superego by suggesting ▪ that it consists of those aspects of ego-closure which depend for their stability on schemata relating to the parent-figures (as archetypal representatives of society); ▪ that “demands” are primarily felt-needs for closure; and ▪ that it is probably misleading to think of the superego as some separate self-contained structure which competes or cooperates with the ego, or with the id, in a rather mysterious and autonomous way.

#### C6.4 More about the likely hierarchical organization of concepts: parallel systems, inversions of control, and consciousness again

In Chapter C3 we considered the likelihood that the various levels on the postulated  $M^nL$  hierarchical scale might be using the same basic substrate. The tentative opinion resulting from this was that the levels  $M^1L$ ,  $M^2L$ , and any higher than these, would all share the same substrate — quite likely within the neocortex; while<263> the  $M^0L$  level would occupy a separate substrate, presumably in the older parts of the brain, though possibly elsewhere as well (see Section C5.4). The  $M^{-1}L$  level was not mentioned in Chapter C3, but it is fairly obvious that it would involve yet another separate substrate. It is, after all, defined in terms of *peripheral* nervous activity (early in Section C5.4). Whether or not such levels share the same substrate is likely to have a significant bearing on the properties of the physical-set elements (or “lists”) in the levels concerned. List-structure, as depicted in Figure C5.2/3, entails actual-or-potential “calls” to other elements which are generally assumed to belong to a population which is *lower* in the  $M^nL$  hierarchy. But perhaps there is no compelling reason why this should always be the case — especially if the higher levels have no fundamental distinction between them to hamper such flexibility.

Bertrand Russell and his mathematically-minded contemporaries were much concerned to clarify the paradoxes which arose from an “inadmissible” use of sets, such as “the set of all sets including this set itself”. But the biological world is no respecter of man-made restrictions, so there is no reason in principle why mental lists of the sort we have been looking at should not include themselves if any useful purpose could be served by doing so. Rather more to the point, they should be able to include references to *other* lists within their own  $M^nL$  level, perhaps reciprocally, and even to include references to lists *higher* on the  $M^nL$  scale!<sup>54</sup> Same-level linkages might possibly be invoked as a means of effectively extending the practical length of lists; but here we will concentrate on some interesting implications arising from the latter suggestion that “membership“-references might extend upwards to higher  $M^nL$  levels.

<sup>54</sup> See original-page 250 above, and its new footnote<sup>53</sup>. — [RRT, 2006]

Given the hierarchical  $M^0L$  structure, there is something of a dilemma as to where *ego* and *consciousness* could be fitted into it. <264> In Traill (1975b), the ego was placed at the  $M^1L$  level (there referred to as “ $L_2$ ”); while it was suggested that “Consciousness *may* be explicable in terms of a *highest* order schema” ... selected from those levels currently available to that individual. Subsequent accounts have left the ego at  $M^1L$ , but some further thoughts have emerged concerning the placing of consciousness. In Traill (1976d, Section E1), the new suggestion emerges that consciousness may be: “some sort of communications-device-or-centre, *separate* from the pyramid-structure itself, and having a more-or-less stable and unchanging status throughout the development process.”

265

Section C3.2 of the present work, ends up by provisionally accepting what amounts to the latter concept: “as a sort of  $M^0L$  level — a sort of local approximation to an ‘all-seeing’ transcendental being.” And yet in Section C6.3, ego (with attention) was seen as a precondition for consciousness — strongly suggesting that consciousness should be closely associated with  $M^1L$ , the presumed level for the ego. How could these two implications be compatible? In topological terms, the solution turns out to be simple once one drops the assumption of strict hierarchical ordering:- One could have a *loop* structure for the communicational connections; and that is precisely the sort of innovation which would be made possible if sets could reference higher-order elements.

We may suppose that the “consciousness structure” (whatever it is in physical terms) is indeed closely associated with the ego (self-concept) and likewise at the  $M^1L$  level with it; and yet it will still be able to “call” or refer to schemata at the  $M^2L$  level, or possibly any levels beyond that, by means of this “inverted referencing”. In this sense it could still effectively fulfil the role of a  $M^0L$ , no matter how many levels of abstraction were added to the  $M^0L$  hierarchy; and yet it could still retain some connections with its <265> presumed original place at  $M^1L$ . Just what balance should be kept between these two types of affiliation is another matter, and it will be worthwhile for us to look briefly at what this is likely to entail:-

266

It is well known that introducing a communicational or control-path loop into a system is likely to cause problems of *instability* — or *overstability*. One form of run-down system discussed by Ashby (1956) arises when the state-determined path of its transitions happens to bring it back to a state which is identical to one it has already passed through; so from then on, it will repeat itself *ad infinitum* unless outside agents intervene such as to give an adequate change-of-course to this dynamic process. Such a tendency to get stuck in a rut, pending a sufficient shake-up, constitutes a type of *stability*. If it occurs in a living organism, it will presumably manifest itself as some sort of paralysis — possibly damaging the organism’s chances of survival, though there may be circumstances when it might aid survival instead; this will depend on ecological balances. Negative feedback, as understood by electricians and economists, will have a similar stabilizing effect (for good or ill); while positive feedback will magnify effects (for good or ill) — possibly leading to system breakdown, depending on the details and parameters of the system.

If consciousness does reside at the  $M^1L$  level, then it is difficult to see how we could control our abstract or concrete thoughts *without* control links (from  $M^1L$ ) to  $M^2L$  and  $M^1L$  respectively. Perhaps we could still acquire the relevant concepts fortuitously, as seems to be the case for sensori-motor development of  $M^0L$ , but apparently we could neither direct our learning activities, nor consciously use the concepts once we had acquired them! Thus the anomalous “upwards” and “sideways” referencing would seem to have an important role in the mental life of primates. But apparently there is a price to be <266> paid for this privilege, and this could turn out to be the risk of having one’s ego “de-stabilized” by interference from our own consciousnesses — either directly, or via the abstract thought of  $M^2L$ ; (and it might be argued that herein lies one danger in attempting to psychoanalyse *oneself*). We shall not pursue the matter further in this chapter, but it

267

is worth bearing in mind when considering the detailed nature of neuroses and psychoses, and the likely *useful* roles played by the Freudian defense-mechanisms.

Before leaving this section, it will be appropriate to elaborate slightly on the points made at the close of Section C5.4, concerning *parallel processing*. It was suggested there, that there might well be at least two different  $M^0L$  levels for mammals: one primitive and archetypal, while the other would be “purpose built” for the neocortex and (presumably) the basis for higher levels of the  $M^0L$  organization. Each would probably develop more-or-less independently, with little or no direct communication between them — in accordance with Ashby’s comments (also cited in Section C5.4) on the undesirability of excessive interconnection. Similarly there was mention of the better documented paralleling of visual and auditory receptive areas of the brain. Then again, it has long been realized that ablation experiments point to a considerable ability of the brain to use alternative (parallel) pathways or mechanisms. And of course, at the much smaller molecular level, it has been a crucial part of the current theory that there will be quite large parallel redundancies amongst synchronizable micro-elements.

For any system like this, we should beware of asking naive questions of the type: “Does the brain process its information by method X, or by method Y?” — inducing us to set up an experiment aimed at a decisive X-or-Y answer. In fact though, it is quite likely that the system as a whole will be quite able to operate *either* way<267> if both methods are reasonably feasible; and even if we can isolate small parts of the system, we might find that the configuration will fluctuate with time (as in chemical resonance). This makes for considerable experimental complication, though perhaps there might be ways for detecting the current state without unduly disrupting it by the very process of measurement itself. (For instance, the various frequencies and patterns found in Electro-Encephalogram (EEG) traces might turn out to be useful indicators of which specific subsystems or modes were currently being used by the brain).

The natural advantages of such a pluralistic system should be obvious. The greater the redundancy and (suitably organized) variety, the better prepared the system will be to face the surprises and buffetings of a capricious environment. Of course if the system finds itself in what seems to be a stable and reliable ecological niche, then there will be a case for *specializing* — dropping some of the cumbersome provisions for “the invasion which never comes” — and perhaps producing great efficiency within the context of the niche, outrivalling its slower all-purpose competitors; and yet the “day of wrath” may still come when the security of the comfortable niche will disappear. But then nature as a whole is also pluralistic. The specialized dinosaurs may go, but there are many other pluralistic cards in nature’s hand, and the overall system of life will tend to continue in many other forms.

And yet there may be still more to be gained from *organizing* such variety to the best advantage. It will be recalled that each  $M^{i+1}L$  level has been depicted as serving to form useful *sets* amongst the members of the  $M^iL$  level below it, and this is indeed interpretable as a trial-and-error attempt to organize the existing variety to the best advantage, while still remaining pluralistic itself. Ashby is surely correct in pointing to the dangers of intercommunication within<268> the brain (at least at the same  $M^0L$  level), and the hazards of loops in general has just been looked at; but insofar as the coordination can be managed “from above” *without disturbing the states of the elements*, then we can lay some claim to having the best of both worlds. Thus perhaps we can say that one interpretation of the importance of higher levels of intelligence is that it gives us the potential for specialization without *necessarily* abandoning our flexibility. It would be comforting if we could be confident that Homo Sapiens, as a race, is capable of realizing this potential through all eventualities!

### C6.5 Distinguishing inputs and acquiring a conceptual hierarchy; success, failure, and the shadow of psychosis

At this stage we should return to the Ashby-type model developed in Chapter C4, and look critically at the practical details implicit in Figure C4.5/2. In particular, we should note that there are at least three different types of input ( $E_1$ ,  $E_2$ ,  $E_3$ ) — each manifestly serving a different function which should not really be confused with the others — and yet we have so far said nothing definite about how such distinctions are to be made. To quote from Section C5.5 (paragraph 8), where the matter was mentioned in passing:-

“... in any live situation it may well be a matter of some considerable subtlety to distinguish which input cues are to be considered as  $E_1$ , and which are  $E_3$  ... And then the situation is further complicated by the need to consider evaluative feedback-input:  $E_2$  for the  $M^0L$  case, to which we may now add  $E_4$  for the  $M^1L$  case — thus introducing another feedback loop into the configuration of Figure C4.5/2.”

[In this context, Ashby’s “ $E_i$ ” nomenclature is beginning to become less helpful because it obscures the supposed relationship with specific  $M^iL$  levels, and the distinction between “straight” information ( $E_1$ ,  $E_3$ ,  $E_5$ , ...) as against the evaluative feedbacks ( $E_2$ ,  $E_4$ ,  $E_6$ , ...). Although this issue will not arise again in the present work, after<269> this present section, it might nevertheless help to clarify the situation if we consider an alternative notation which would correspond to the  $M^iL$  notation (in which each  $M^iL$  level was subdivided into a lower sub-level of elements “ $m^i$ ”, and an upper sub-level involving sets and groups “ $m^{i+1}$ ”). Thus we might now use a notation something like  $IP^i$  to represent the *In-Puts* to the respective levels  $M^iL$ ; and differentiating this further into  $IP_r^i$  and  $IP_e^i$  — as variants to specify raw data or evaluation, respectively. Thus  $IP^0$  would consist of  $IP_r^0$  ( $=E_1$ ), and  $IP_e^0$  ( $=E_2$ ) — with these relating respectively to  $m^0l$  and  $m^1l$  (which collectively constitute the sensori-motor level,  $M^0L$ ). And similarly for the other double-levels.]

270

As adults, we are inclined to take such distinctions between the different types of input for granted — until we hear stories of typists mistaking the typing-instructions for the text itself, or until our computer mixes up the different levels of its data when we fail to spell out every distinction according to the rules; or indeed until a psychotic patient appears incapable of reliably making distinctions of this sort. Moreover, children seem to be much amused by (comprehended) jokes which play at violating such distinctions — arguably because they thereby demonstrate to themselves, and to others, that they have mastered some vital part of this aspect of everyday reality; (internal closure again). Thus:-

*First child:* “Say something!”; *Second child:* “Something!”.

But then it seems plausible that many adult joking-practices may serve a similar function in relation to levels within the social context. Here the purpose of “ribbing” a non-group-member may be seen as demonstrating that he does not have the necessary “in”-knowledge to distinguish fact from a *dead-pan delivery of fiction*; or at least the teller does establish his own position even if the “victim” *can* wend his way between the<270> more concrete facts and the more abstract joke-component. In fact, such mutual negotiation of the distinctions is actually likely to be more satisfactory all round, and contribute to social cohesion (Fenichel, 1946) — unless there are other reasons for wishing to exclude the outsider, in which case there will presumably be dissonance at the turn of events, and some measure of resentment within the joke-teller.

271

But let us return to more clear-cut cases, and try to establish a measure of detail as to how we ever achieve the ability to make such distinctions within the mass of information which is presented to us. This should then shed some light on why the psychotic, and the computer, have difficulties in these matters.

First we may deal with the evaluative feedbacks:  $E_i$  (where  $i$  is even), or equivalently  $IP_e^k$  (where  $k$  is an integer). As far as the hereditary or “hardware”  $M^{-1}L$  level is concerned, there will presumably be no such feedback for the individual, though clearly there will be for the species via natural selection *between* individuals. So, for our present purpose, we may disregard any question of “ $E_0$  or  $IP_e^{-1}$ ” as potential modifiers of the  $M^{-1}L$  level. Looking next at the sensori-motor stage and the  $M^0L$  level, it is clearly closely related to physical pleasure/pain, of the traditional straightforward “reinforcement” type; and such feedback was seen as tending to stabilize existing constructs by “tags” of approval for those “under attention” when the reward occurred. Similarly, any negative reinforcement would tend to de-stabilize by means of negative tags, and presumably directed by attention in the same sort of way. (The “decision” as to what will be classified as pleasurable or painful has already been taken in the evolution of the species, and is incorporated in the  $M^{-1}L$ -level structure).

And yet there was more to the sensori-motor period than just the physical aspects of the pleasure principle, though this is perhaps <271> not apparent at first. If the individual concerned is making any significant headway towards the construction of object concepts (in the sense of modelling the objects’ group-like properties, and not simply acquiring rules-of-thumb for handling them), then it is difficult to see how this could possibly be done without using internal-closure criteria. (Of course it might be argued successfully that some animals, while starting into the sensori-motor period, never get to the stage of developing internal closure. Such possibilities should be borne in mind, and if they turn out to be valid then we might reasonably consider such modifications as re-defining the developmental periods in a more optimal way). Anyhow, the supposed internal reward derived from such internal closure does constitute a type of feedback, even if it is not strictly an “input” in the usual body-boundary sense; so it will not necessarily cause the same problems of disentanglement as those inherent in the various  $E_{\text{integer}}$  inputs of Figure C4.5/2. Nevertheless it might be useful to formally label it as  $IP_i^0$ , with the understanding that it does originate internally — hence the subscript  $i$  for “internal”, (not to be confused with “ $i$ ” as a disposable integer in the earlier discussion).

So far there do not seem to have been any awkward decisions to be made about how to use the input. Hereditary structures and inbuilt random-generating features have presumably directed attention to this or that sensory phenomenon, so that a certain distribution of sensory (and motor) hereditary scheme-elements have been subject to a potential learning-process; but this has presumably affected the  $M^0L$  level alone, since the higher levels have not yet materialized, and we assume the  $M^{-1}L$  level to be uninfluenced by learning. Once the  $M^0L$  level has developed stable schemata for objects or other group-like structures, these will provide the elements for the  $M^1L$  development to begin — and here there will presumably be a new need for evaluative feedback <272> as a means for choosing among this new crop of elements. How then is the evaluative input correctly allocated between the two levels?

Considered in absolute terms, there probably is no such clear-cut allocation, and the same evaluative signals will initially descend equally on the attended-to elements of both  $M^0L$  and  $M^1L$ , so that each is likely to share “praise or blame” along with the other — however unjust this may seem to be, and however retrogressive its effect. Moreover it seems likely that the  $M^2L$  level will receive the same indiscriminate treatment when it appears on the scene later on. (Indeed the same arbitrary distribution will occur to some extent *within* each level, because there is no guarantee that the phenomena attended to are actually related to the reward-or-punishment. However such situations are fairly rapidly corrected using versions of the “homeostat” principle discussed in Chapter C4 above, with behavioural consequences familiar to users of the Skinner-box experimental technique). **NB:**Thorndike (1911) had been early in noticing an apparent asymmetry between positive and negative reinforcement: the “pain” case giving less predictable results — arguably because it is not always easy to predict the level (or the schemata within a level)



which will switch-over in an “attempt” to avoid the noxious stimulus; and there are similar ambiguous implications for punishment in education! Experimental design, for the standard laboratory paradigm of the controlled experiment, appears to solve this problem: the Subject’s attention is deliberately constrained into the desired channels, by such devices as saliency or training, so it is more-or-less known which level will be influenced most significantly. Of course this is fine as far as it goes, though it does rather seem to trivialize the Subject as an otherwise interesting system-to-be-investigated. It is this inherent limitation which has been so usefully transcended by some of the “less respectable” work, such as ethology. <273>

But looking again at evaluative feedback, it would seem that we actually do eventually manage to deal with many of our pleasure/pain sensations by responding at the correct  $M^0L$  level. True we may panic or act impulsively in response to stimuli which would be more appropriately handled by a “thoughtful” approach (using the higher  $M^0L$  levels); or we may make the opposite mistake when it would have been better to act on impulse — “Wise men and grocers: they weigh everything!” (“*Zorba the Greek*”). However that may be, our various levels (if we accept their existence) do seem to develop along correct lines, in some of us at least; and this must presumably be due to the steering influence of evaluative feedback — directed, on average, to the appropriate levels. So let us consider what particular influences might tend to perform such steering correctly.

Probably *the* most important factor here will be selective attention of various sorts. To start with, it rather looks as though the significance of Freudian erogenous zones is precisely that their sequential pattern of ascendancy *does* direct the individual’s attention to specialized types of phenomena which are likely to be the most important ones for that particular stage of development. After all, the Sensori-Motor ( $M^0L$ ) stage does involve *oral*/manual/visual/auditory experiences as a basis for object-concepts; whereas the crucial task for the  $M^1L$  development of the following period is the acquisition of an adequate self-concept, and here the “*anal*” activities of *autonomous* giving-or-withholding deserve close attention — along with the mysteries of “When does a part of me cease to be part of me?” Clearly it is likely that such vital-at-the-time matters will be promptly attended to if the individual is granted the bonus of erotic pleasure by so doing.

[Development in this way would constitute another example of orthomaturation. The “pre-programmed” unfolding of erogenous zones, <274>in a strict sequential schedule, pre-supposes that the appropriate environmentally-determined experiences will be available at these times. If these experiences do not occur, or if they bid for attention at the wrong time when erotic-attention is directed elsewhere, then it is probable that the “wrong” lessons will be learned. Moreover it seems likely that the secret of a successful *society* or *culture* lies in its particular knack of institutionalizing such “wrong” lessons such that they turn out individuals who are actually “right” for that society, as a stable ongoing system — even if the lessons were sub-optimal from the point of view of the individual, considered as a potential member of some other culture. (Margaret Mead, 1928/1954, 1935/1950).]

Another means for usefully directing attention would probably be provided by the tendency for the mind to *remain* concentrated on the same area of thought, for some time at least. The usefulness of this “mental set” depends on a tendency for phenomena in the environment to retain a similar logical connection for more-or-less extended periods of *time* (in addition to the tendency for them to have *structural* features in common with our postulated  $M^0L$  hierarchy); thus if one has just been actively involved with concepts of food, then one will tend to retain this outlook for any new phenomena — and, on the average, such a bias will turn out to be well-founded. But such selection is presumably occurring *within* a particular  $M^0L$  level; so would the same apply between the levels? In fact it seems that we do maintain such level-specific attention:- If I am concentrating on abstract matters, I will tend to continue to do so for a while; (though interestingly enough, I may also be able to maintain some degree of *separate* attention to some

other task at another  $M^N L$  level — such as driving a car! Yet it seems that there will be times at which I must concentrate my “full” attention on one or the <275> other; quite likely because the particular problem has come to require the active involvement of other  $M^N L$  levels — as when I must think logically about the route I must take, or when the gearstick jams).

Once the ego has appeared, we must expect that it also will play a major part in directing attention; and in accordance with the arguments of Section C6.4, we may suppose that this could occur for any  $M^N L$  level — though it is by no means obvious that we actually do or can attend to  $M^0 L$  or  $M^{-1} L$  levels, perhaps due to lack of loop-pathways which might provide needed negative feedback. Often such attention-biases will be “unconscious” but clearly they may alternatively be directed *consciously*. For the want of any better suggestion, we might reasonably suppose that the mechanism which does the actual directing of attention is itself the subject of attention at that moment. [How it is possible for the ego-ensemble to monitor and control what is apparently another part of itself, is a matter which we will not discuss in detail here:- Perhaps it operates on two levels ( $M^1 L$  and  $M^0 L$ ), and it might thus operate as a miniature replica of the Ashby type of system which we discussed in Chapters C4 and C5]. Anyhow, as well as promoting attention, we may take it that there will also be “suppression” (conscious) and “repression” (unconscious) — as we shall see.

Ego-control is presumably one form of learned selection of attention, but there are likely to be other learned focussing methods which do not depend on the ego-schema to organize them. All that is needed, in principle, is pre-existing attention to a relevant set/list which contains a call or reference to the “focal” item, and perhaps some suitable stimulus to activate the set-schema — though the fact that it is already under attention would arguably suffice. Thus, instead of using the ego-complex with its relatively ubiquitous “ $M^0 L$ ” control-connections, we would seem to be using a <276> comparable-but-restricted schema from the  $M^N L$  level which is one step higher than the focal item. One might also argue a similar case for “associations” within the same level, though it seems likely that such mechanisms would often turn out to require the participation of the tethered-sets to provide the extensive definition of linkages; (of course these would not be required if a satisfactory method for establishing direct, intensively-defined linkages could be adequately explained; or if there were a plausible case for hereditary or mutant connections on common chromosome-like micro-elements).

We have been considering possible mechanisms whereby evaluative feedback might be channelled in the direction of the most appropriate  $M^N L$  level — the one most likely to be praise-or-blame worthy. All the suggestions so far have involved *attention*, either *directed* onto the coding concerned, or persevering *inertially* in the absence of any stimulus to change further. But there is a further possibility which might also be classed as attention (though such categorisation is not crucial here), and this is the case of a structure which is more-than-usually *susceptible* to the effects of evaluative input stimuli — due to its own endogenous structural instability properties when these are also related causally to the evaluative feedback obtained.

To be more specific, consider the case of a set of elements in which there is some measure of internal closure, but which fail to form properly into an adequately self-consistent “group-like” structure. Thus, like many scientific theories, it will be stable enough to withstand the (postulated) normal processes of enzymic “garbage disposal”, and yet it will not really have made the grade as a fully complete and stable structure according to the prevailing criteria. Its “loose ends” may therefore be thought of as being “extra reactive” — somewhat analogous to a sodium atom “looking for” <277> a halogen atom so that their collective orbital pattern will be reasonably stable and complete. Such persistent dissonance seems likely to attract attention, and also thereby to become involved in the initiation of behaviour and its consequent evaluative feedback; though the outcome from this is likely to fall short of the ideal:- If the feedback is negative, then the imperfect schema itself is likely to be *repressed* (tagged as “unsavoury” and therefore not to be

admitted into attention if possible, or actively interfered with to prevent its future expression, but not usually annihilated because its residual stability is too great for that). If, on the contrary, the feedback is favourable, then those other schemata involved in bringing the shortcomings of the dubious structure into attention will be likely to suffer some degree of repression instead. In neither case will the problem really be solved; instead it will just have been swept under the carpet — though in real life it often turns out that this is the sort of thing which we must just make do with, at least in the short term. After all, what practical man will bother unduly about finding a perfect generalization, as long as he can cope satisfactorily in the real world by using *ad hoc* hypotheses in conjunction with a manageable set of identifiable *limitations and exceptions*? Such conceptualizations even enjoy a degree of scientific respectability — at least temporarily; Cartesian dualism is a case in point, and so is the wave-particle dualism of physics.

However we are beginning to encroach on the complementary topic of *non-evaluative* feedback, the structures evolved to make use of it, and how it is that there will actually be distinguishable  $M^0L$  levels — whether the evaluative feedbacks can be correctly attributed to them or not. Let us therefore turn now to consider the  $E_1, E_3, E_5, \dots$  (or  $IP_r^0, IP_r^1, IP_r^2, \dots$ ) input paths, and how they might be<278> differentiated.

279

Let us start by reminding ourselves concerning the type of construct which we expect to be developed in each of the respective levels; (see Table C5.4/I). Sensori-motor development entails the building up of *object* concepts using hereditary sense and action stereotypes as basic elements. Next (for  $M^1L$ ) we have Concrete Operations development involving interactions among objects, including other people, and one's own self — describable perhaps as the *piecemeal laws of physical nature* and the “*laws*” of *particular social interactions*. (Note the apparent beginnings of a dichotomy here, a point which we will come back to from time to time). Next there will be Formal Operations dealing with “abstractions”, which seems to mean an internal involvement with *sets of piecemeal laws*. And so on perhaps, to yet higher levels.

There is nothing particularly profound in suggesting that such a hierarchical structure has evolved because, and only because, the real outside world can best be modelled in this way — and that the real world does, by-and-large, actually have that sort of structure. However it would perhaps be more significant to suggest that much of this mental structure is re-created anew in each individual — as a *result* of his interaction with the environment which has this structure. Clearly there will be some important hereditary guidelines such as pre-determined  $M^{-1}L$  elements (encapsulating many generations' experience in using elementary bases for object-modelling), and the pre-programmed sequence of emergence for the erogenous zones, discussed above. Moreover it seems likely that for the more primitive animals, and the more primitive parts of our own brains, the nature of  $M^0L$  structures will also be hereditarily determined. But there is also clearly much scope in primates for the development of individual differences, *despite* a similar-or-identical genetic legacy. <279> In fact, the higher levels of the  $M^0L$  hierarchy probably depend for their structure almost entirely on experience gained through interaction with reality, and only minimally on hereditary encodings. This independence from genetic influence will be particularly true if the various higher levels all share the same substrate, and have to arrange their own differentiation between levels. Nor will it make much difference to this independence if we suppose that different parts of the brain evolve their own separate hierarchical structures more-or-less independently — with each developing along similar lines, under similar influences.

280

It is interesting to consider the above-mentioned dichotomy (*physical-object-logic* versus *social*) in this light. Solid objects and the related “hard sciences” have a more discernible and regular manifest structure than we can find in the “social sciences”, so it is no accident that examples to illustrate the postulated hierarchical structure have generally been “hard-science” oriented. Accordingly, it should surprise no-one if any  $M^0L$  representation of social phenomena were much more diffuse and lacking in the upper levels of abstraction. Indeed it would probably

constitute a prime example of the use of sets-of-exceptions and special cases alluded to four paragraphs ago; and it would doubtless entail extensive compartmentalization and “logical inconsistencies” both within itself, and *vis a vis* the supposedly monolithic “hard science” structure (or structures!). Emotional guidance and tagging would presumably come into its own here, and so too would the emergence of the later erogenous zones: anal and phallic/genital.

This is not to say that social phenomena are inherently devoid of precise hierarchical structure. Indeed one of the main purposes of the present work is to demonstrate that it makes sense to envisage the existence of such structure, even though it may be beyond our <280> powers to demonstrate it clearly. (If this basic structure is accepted as a premise, then this would mean that we could notionally replace a mentalistic view of social matters by a “physiological”/ mechanistic one; see Section C6.1, above). But even given that basic hard structure does exist for social phenomena, this structure is certainly not manifest nor easily construed. And rather more important:- Even if we did have very comprehensive structural models, this would not, it itself, guarantee that we could reap practical advantages from this knowledge; and probably we would then have to re-organize it into some *new* simplified model which hopefully would give us a better insight into how to control the environment to our best advantage. Indeed we would quite likely generate a series of such approximate models, to be produced under varying circumstances as if they were “exceptions” derived in an *ad hoc* way! Possibly this principle will be illustrated usefully in the following pages when attempts are made to explain neurotic or psychotic aberrations. Anyhow, this takes us conveniently into a consideration of the failure of the normal hierarchical organization:-

It is instructive to turn to the early pages of Chapman and Chapman’s book (1973) and consider their overview of the symptoms of schizophrenia in the light of the above discussions. Let us look at some relevant fragments:- (page 4) “[the patient’s] intonation and gestures seemed to indicate that he felt he was giving a meaningful reply” — which raises the question: “What are the principles by which this discourse is organized?”. Then, his answer may be described as a “fragmentary description of several vaguely similar scenes, and he skips quickly from one to the other.” In the context of our present theory, this looks rather like a case of a breakdown in the ability to use extensive definition (which would perhaps entail attending to a particular  $M^2L$  set, and using it to direct one’s <281> selection of lower level elements, thus “keeping to the point”). Such a failure might plausibly leave the patient to fall back on less-organized intensive definitions or other comparatively nebulous forms of “association”.

Then, on page 5, it seems that the patient is “trying to talk about several themes” and that he “can handle only one idea at a time” — also potentially attributable to the failure of some expected set-organization to marshal its relevant components simultaneously, for whatever reason. As another example, it seems that “the question is too abstract for him” — suggesting a similar interpretation, and perhaps also specifically implicating the  $M^2L$  level due to the apparent deficit in Formal Operations. Similarly, where there are some of the features of a regression towards infancy, this may reasonably be attributed to a breakdown or partial malfunction of the higher  $M^pL$  levels, which would be absent in infancy anyhow; (the “inability to assume the point of view of his listener” would seem to be closely related to this issue because, as Piaget has demonstrated, such egocentric conceptualization and perception are characteristically present during the Concrete Operations period — at least in the wider sense of the term). However (page 7): “few, if any, schizophrenics consistently behave in a ‘schizophrenic manner’”, so it would be rash to assume a total breakdown of any  $M^pL$  level. Finally, “intrusion of his feelings ...” might be put down to a weakness of  $M^2L$  “resolve”.

Unfortunately there are other aspects of clinical schizophrenia which are less amenable to such explanations. These involve an apparent wilful negativism, which is difficult to explain in terms of  $M^pL$  deficiency because the patients give the impression of being all too competent in

set-handling with the deliberate intention of being difficult! Thus (page 8, quoting from Kraepelin): <282> “they deliberately turn away their attention ...” and yet “in the end ... a kind of irresistible attraction of the attention to casual external impressions” may draw them round — which suggests that M<sup>n</sup>L deficiency may also exist alongside the negativism, and probably with some sort of causal interrelationship. Further instances (page 9) are cited from Bleuler, involving “evasion or *paralogia*” — such as the apparently deliberate adding of *one* to all numerical answers. Laing’s (1960) account of the nature of schizophrenia as being a rejection of the apparently-hostile outside world, also sounds very similar — though seen from a different angle. This (perhaps justified) *paranoid* view of the world, is portrayed by Laing as leading to the seemingly rational choice of trying to escape from the world into one’s own hermit-like ego, in order to protect that ego. But the tactic actually backfires (arguably due to the consequent lack of external closure, and hence the non-maintenance of important schemata) thus leading to a psychotic state.

Seen in this light, paranoia seems to be an interesting special case; (see Section C7.7, below). Even if the essence of paranoia is structurally quite different<sup>55</sup> from “psychosis proper”, it may nevertheless be seen as one of the likely *routes* into the structural deficiency which does produce the attention disorders of clinical schizophrenia. If it does facilitate the onset of psychosis in this way, then it is easier to see why the two types of symptom tend to co-exist:- the paranoia would tend to cause the psychosis-proper; and this in its turn could well reinforce the paranoid feelings — thus producing a vicious circle of causality.<283>

We will return to questions of psychosis in Chapter C8, when a more systematic consideration of the clinical and experimental evidence will be embarked upon.

284

### C6.6 Dreaming, sleep, and sleep-modes

Our task in this section will be to draw together several disparate viewpoints concerning sleep, its nature, the purpose it might serve, and some thoughts on how it might be brought about. In particular, it would be helpful if we could reconcile Freudian dream-theory with the more recent distinction between different modes of sleep, and reconcile both with the current theory including the role proposed for sleep (in Section C2.3, above). By and large, evolution sees to it that there will usually be a *reason or functional significance* for any surviving structural or behavioural quirks of nature — even if no-one has yet found the relevant explanation; so it would not be surprising if all the details of sleep had their own particular significances. (Freud himself made very much the same sort of point<sup>56</sup>, though expressed rather more weakly in terms of intuitive appeal, and referring to dreams alone rather than sleep as a whole).

The explanation which Freud<sup>57</sup> offers is that “A dream is the<284> fulfilment of a wish”; (1900/1953, page 91 and Chapter III). We may or may not agree that this has served well as a working hypothesis; but there are at least two aspects of this formulation which deserve ultimate

285

<sup>55</sup> This need not be the case. The basic structure could be similar to that for psychosis “proper” (which involves objects, logic, and attention as tangible signs) — but differ by being primarily involved with social objects and affiliation-networks. <283>

<sup>56</sup> “It need not necessarily be possible to infer a function of dreaming ... from the theory. Nevertheless, since we have a habit of looking for teleological explanations, we shall be more ready to accept theories which are bound up with the attribution of function to dreaming”. (Freud, 1900/1953, page 75). One might perhaps add that until such an explanation is found, our theory will be disturbingly lacking in internal closure. Incidentally, Freud’s heretical playing-down of vain hunting after the observable, in favour of closure, seems to have been partly prompted by Scherner (1861) via Volkelt (1875); (Freud, 1900/1953, pages 84-87). <284a>

<sup>57</sup> After Griesinger (1845/1861) and Radestock (1879). <284b>

clarification — before it is endorsed as well-supported by closure, or modified to that end, or abandoned altogether. The two points requiring clarification seem to be (i) the meaning of “wish”, and (ii) explaining how unpleasant nightmare phenomena can be examples of “wish-fulfilment”.

In much of his work, Freud was attempting the very difficult task of postulating a structure, as explicitly as possible, despite the lack of any helpful neurophysiological clues which might have helped him to bridge the knowledge-gap between the mental and the “hard sciences”; (Traill, 1976b). He was, in fact, quite well aware of the existing shortcomings of physiology and looked toward a time when the situation might be remedied; but he was nevertheless prepared to proceed despite these deficiencies. Thus, for instance, “There is no possibility of *explaining* dreams as a psychological process, since to explain a thing means to trace it back to something already known, and there is at the present time no established psychological knowledge under which we could subsume ...” (etc.); (1900/1953, page 511). Accordingly it was scarcely feasible for him to enquire too deeply concerning the meaning of words like “wish” ((i) above); and although he did manage to explain the nightmare (ii) in terms of wish-fulfilment — as a sort of masochistic trade-off (1900/1953, page 557) — his account can nevertheless benefit from some structural tightening-up. Whether or not the current theory is correct, it can at least offer such a structural basis for attempting this sort of further development.

Let us try to interpret the idea of “wish-fulfilment” in terms of linear micro-elements and  $M^1L$  hierarchies. In fact there is no <285> great difficulty in visualizing an ego-schema in which there is a painful lack of closure reflecting some powerlessness to cope autonomously with a disoblging real world; nor should we be surprised if the individual should experiment mentally with ways of resolving this dissonance which threatens the very basis of his self-concept as an efficacious being. A primitive attempt at solution would be an all-out “Death-or-glory” confrontation with reality, with no pause for consideration. While such a ploy might occasionally work, it would generally turn out to be a poor gamble; so some sort of “experimentation” within the safety of one’s own mental model system would usually be preferable as a start — leading perhaps to a subsequent judicious testing of any promising putative solutions. This scarcely needs to be said of problems which manifest themselves clearly at the logical  $M^2L$  level. Dreaming is not usually acknowledged as necessary for the solution of problems in “hard science” (though Kekulé’s celebrated dream, leading to the notional discovery of the hexagonal benzene ring, is a notable exception; (Read, 1947, page 341)). Such problems are apparently so well structured that it is possible and preferable to use formal (even doctrinaire) techniques for making the best use of the available information — and to do so in an awake state. And yet even problems of this sort often have fringe aspects which are less amenable to formal treatment, so that it may well pay us to pause and “sleep on it”.

286

Suppose we generalize the Freudian formulation somewhat, and suggest that the function of dreaming (as we know it) is to juggle the elements of our  $M^1L$  conceptual level in an “attempt” to find better solutions to the incompatibilities between the schemata of this level. This would entail actions and relations amongst objects, including “social objects”. Now as “self” is the salient object in anyone’s world-view, and as one’s concepts of action and relationships <286> apparently based on egocentric elements of action, it would seem to follow that all or most “thought experiments” at this level would entail the self-concept in one way or another. Thus the new formulation given here would seem to subsume Freud’s wish-fulfilment as a special case or even, it might be argued, be co-extensive with it.

287

Armed with this more structural explanation for dreaming, we are now in a position to attempt a more credible interpretation of “masochistic” nightmare-dreaming; but it will be helpful to start with the phenomenon of masochism itself. The Freudian conceptualization, as outlined by Fenichel (1946/1971, pp 73-74), depicts masochism as a package deal entailing a net gain in

satisfaction, despite a very significant element of pain, which is seen as “a necessary evil ... unfortunate but unavoidable”. Such sub-optimal solutions would seem to be just the sort of situation which we were considering for the more complex types of cognitive dissonance, in Section C6.3. The problem barely arose in the simple tripartite case considered in Figure C6.3/1, but for the more involved cases it became clear that cluster-analysis techniques, or similar imperfect-solution-finders, were the sort of mechanism which we must expect. Even so if, in principle, a much better solution could be found by formal means, the system must meanwhile be capable of carrying on and progressing in a less neat, but more robust, fashion. Masochism then, is presumably a particular more-or-less stable solution reached using such a technique — and the same can doubtless be said of all the other neuroses *as well as* many or all the indispensable features of our  $M^1L$  levels. By contrast, dreaming seems to be the main *process* in which a “re-shuffle” of the existing  $M^1L$  “clusters” can take place.

In one sense, dreaming may be thought of as a temporary state of insurrection! — or perhaps as a stop to hold elections in the <287> light of events which have occurred since the previous poll. Anyhow the result is a “capacity and inclination for carrying out special psychological activities of which it is largely or totally incapable in waking life.” (Freud, 1900/53, page 82). We may suppose that, during waking life, the  $M^1L$  status quo is controlled (or contrived) from exogenous centres; but during dreaming it seems that these controls are removed<sup>58</sup>, and “local” configurations are left comparatively free to find their own equilibrium in their own way. Thus distressing ideas may all become switched to pleasant ones — “a palpable ‘wish-fulfilment’ ...”; (Freud, 1900/53, page 556). Or alternatively, “An unconscious and repressed wish [from the “id” at  $M^1L$  or  $M^0L$  ?], whose fulfilment the dreamer’s ego could not fail to experience as something distressing, has seized the opportunity ...” — offered by comparative freedom and a new local configuration arising from “the day’s residues” — to present itself as a new potentially acceptable picture of reality. (*Ibid.*, pages 557 and 573).

288

Of course there is no guarantee that the picture of reality offered will necessarily be correct, and there is even less chance that it will be found acceptable even if it is correct; however the effort will have been made, and such reviews of the current model would seem to be just as necessary here as in any business enterprise which would hope to survive in a changing world.

On awakening, the new configurations are rudely subjected to what almost amounts to an alien culture. In many cases they will simply not make any recognizable sense in consciousness, nor offer any new stability in any available broader context, so they will presumably just disintegrate without any permanent trace. In other <288> cases they would become assimilated into the mould of the existing schemata, so that “the dream loses its appearance of absurdity ..” as seen in the light of  $M^2L$  rational thought; (*ibid.*, page 490). Such a *secondary revision* looks very like the sort of transformation which happens to a story or picture when it is reproduced by persons from a different culture who are unfamiliar with the nuances of meaning implicit within the original setting; (Bartlett, 1932). Probably there is no mere coincidence in this similarity; in both cases there is presumably an attempt being made to recover closure internally — among elements which arise separately from different sources, and so show little initial promise of having collective group-like properties. Of course, once in a while, a new superior closure will be found — surpassing the preceding structure in “mathematical elegance”. This is presumably where real progress will take place, ultimately justifying the whole roundabout procedure.

289

Until after World War II, there was probably not much point in distinguishing between sleep and dreaming in any theorizing on the function of dreams. However it is now common knowledge that there are at least *two modes* of sleep with markedly differing characteristics: *Slow*

<sup>58</sup> “Self-consciousness is suspended or at least retarded, ... ”  
(Spitta, 1882, p 199; quoted by Freud, 1900/53, page 90). <288>

wave or “Orthodox” sleep, and “Paradoxical” or *REM* (*Rapid Eye Movement*) sleep. Moreover it has been established that dreaming, as we know it, is associated with the brief periods of REM sleep, and not with the Slow Wave variety which accounts for about 80% of sleep in adult humans. (Jouvet, 1967; Kleitman, 1963; Oswald, 1964, 1966, 1970).

Thus it would appear that the above discussion about the function of dreams has offered an explanation of REM sleep only. So what sense can we make of the residual Slow Wave sleep? While there is no decisive lead as to what the answer might be, it is worth remarking that dreams (as we know them) seem to deal mainly or <289> exclusively with  $M^1L$  matters, while any re-shuffling of ideas during waking-hours will mainly concern  $M^2L$  concepts; so what about the other levels? We may of course dismiss the  $M^1L$  level as being immutable within the individual, and this leaves  $M^0L$  as a plausible area of concern for Slow Wave sleep — assuming it has any function at all. If that is the case, then it would seem that there is another sort of “dream” going on during slow-wave sleep, and that this deals in re-shuffles of Sensori-Motor sets and semi-groups. Unlike REM-sleep, this  $M^0L$  activity would presumably have no direct concern with the *activities* and status of the ego (though it will probably be concerned with its bare object-like basis), so we might expect that its relevance to Freudian theory would be somewhat circumscribed. In any case it is unlikely that much if any of this activity would ever be retained in consciousness in view of this remoteness from ego-interest, though I understand that there is some slight evidence in favour of simple realistic memories emanating from this non-REM sleep activity; (Pound, 1977; after Rechstaffen *et al.*, 1963).

Taking this allocation of roles as a postulate, there are several predictions which we might reasonably make about the two modes of sleep and the proportion of time spent on each. One might, for instance, expect different types of stress to produce different patterns. However here we will only consider cross-species and cross-agegroup differences. Firstly we would expect that animals which exhibit no  $M^1L$  (Concrete Operations) capabilities would also have REM-free sleep — with corresponding compromise characteristics for intermediate cases. This does indeed seem to be the case (Jouvet, 1967):- The tortoise shows no REM-sleep while the hen shows very little, and the largely stereotyped behaviour repertoires of such non-mammals would appear to be almost entirely sub- $M^1L$  in their nature, with learning limited to certain circumscribed  $M^0L$  constructions <290> — of which the most spectacular is the phenomenon of “imprinting”. Mammals, on the other hand, are generally more concerned with learning anew the relationships between objects, involving  $M^1L$  Concrete Operations — and their proportion of REM-sleep is also correspondingly higher. Moreover sheep are arguably “less bright” than the other mammals considered here (rat, cat, and man), corresponding to their somewhat lower percentage of REM-sleep; and it is reported (Pound, 1977) that those lowliest mammals, the echidnas, exhibit an absence of REM-sleep similar to that of non-mammals.

Across age-groups, we might expect that the older an animal becomes (up to maturity) the more it will become pre-occupied with activities involving the higher  $M^0L$  levels. Accordingly we would predict that adult animals would show more REM-sleep than the neonates of the same species. In general, however, this is not the case at all; indeed quite the reverse seems to hold for mammals — though on the sparse evidence supplied here it could well be true within the non-mammal category. There seems little point at this stage in offering any detailed speculation as to why this should be so, though clearly this is a matter which deserves attention in the future. Suffice it here to suggest that there may well be extra complications in the more advanced mammals — complications which we have not yet formulated, or perhaps not even envisaged. Anyhow, this suggests that, even if we are on the right track, we still have a great deal to explain. In the circumstances, this should not really surprise us.

Before concluding this section on sleep, we should perhaps consider briefly what sort of mechanism or mechanisms might control which mode of sleeping-or-waking will be operative



within the individual animal at any given time. It is all too easy to adopt what amounts to an authoritarian view of the system and claim that<291> “the orders” come from such-and-such a centre; but of course this merely shifts the problem (even if the assertion is correct) because then we should properly ask how this “centre” decides the mode it will support. It seems likely that the most fundamental form of regulation will consist of competing attempts (mutually inhibiting) by various subsystems to stop other ongoing activity while they clear up their own state of comparative disarray — comparable to stocktaking, or sorting and filing accumulated correspondence. One might perhaps think in terms of such subsystems becoming increasingly inefficient due to unadjusted configurations, until the worst-affected reaches some sort of threshold and bids to shut itself off from the others, for the time being. (We might provisionally think of these subsystems as being: *consciousness*,  $M^1L$ , and  $M^0L$  — corresponding to wakefulness, REM-sleep, and Slow-Wave sleep, respectively). Of course, in so far as overall coordination is required here, some sort of “semi-authoritarian centre” will be needed; but this should be seen as a consensus-device rather than as an all-powerful feudal lord. In time, we might expect habit schemata to play a part in ordering sleep modes — in conjunction with periodical influences both outside and internally; but the fundamental instigator would probably be the consensus balance.

In this connection, it is perhaps appropriate to mention the model proposed by Kilmer, McCulloch, and Blum (1969). This is a computer model in which it is sought to simulate the supposed activity of the Reticular Formation in selecting modes of behaviour — using a consensus approach. It will thus be useful to bear this model in mind in any attempt to elaborate this issue further; its formal cybernetic features stand a good chance of being correct, even if we are less sure concerning the details.

Finally, we would do well to consider how such mutual inhibitions<292> might be physically put into effect. It is generally assumed that specific nerve-fibre contacts would be used — in effect constituting a bounded-extensive definition of the addressees. Leaving aside the question of how signals are to be directed into these channels in the first place, such an explanation would scarcely be adequate for ensembles in which the active elements are of molecular dimensions (rather than cellular). A tethered-extensive definition would also tend to be totally unwieldy, and probably impossible to set up. By elimination then, it looks as though such inhibitions may have to be addressed *intensively*, to specific sites on each element concerned in the process.

## C6.7 Bio-energetics and Pharmacology: Freudian “Mental Energy”

### *If linear molecules really are vital, what signal-mechanisms could they offer?*

It *seems* to be obvious that any discussion on matters relating to neuropharmacology should start with the chemical preparations themselves, or with the clinical effects which they produce. However now that we are armed with some sort of structural idea about what may be the details and purpose of molecular activity in the nervous system, there is some point in attempting an alternative approach:- Let us elaborate the likely details a little more explicitly, and then consider in what ways this system might be open to chemical interference or modification, and the likely clinical effects which might plausibly follow. It will then be comparatively less important to concern ourselves with detailed matters of chemistry; and this aspect could then be dealt with subsequently, in the light of particular theoretical requirements. Of course any such further elaboration is also likely to facilitate other external tests of validity, as well as such internal tests as the construction of properly self-organizing computer models.

For obvious reasons, traditional neuropharmacology has concentrated on the synapse. In view of the present theories, we should now<293> also be examining possible mechanisms (and vulnerabilities) of:- {a} How elements might *specifically address* and call each other (“naming”

or “intensively defining”); {b} How cue-signals might *traverse along* an element; and {c} How logic elements such as “*And-Gates*” might operate at this level. These questions, especially “{a}”, will involve us in some rather specialized theoretical matters concerning ultra-micro energy transfer.<sup>59</sup> Of these, the more speculative and heretical suggestions, concerning unobservable structure, may well turn out to be superfluous or wrong. However it seems worthwhile to introduce them as being sufficiently plausible to merit tolerant consideration, because if they should happen to be right, we would have great difficulty in trying to arrive at them systematically via orthodox approaches which emphasize impartial observation.

Now let us postpone “{a}”, the problem of address-labels, and deal first with:-

### *{b} Internal signals within molecules — what form could they take?*

Let us begin by taking a closer look at the linear microelement, as depicted in Figure C5.2/1, and the likely behaviour of the string of sites along it. It has been supposed that some sort of discrete signal will, in favourable circumstances, travel along this string of sites — thus potentially triggering the release of other *free* signals as chemically-induced molecular-photon emissions (probably in the infra-red range, and phase-related to those from other sources if they are to carry any effective message across any appreciable distance).

[If the linear micro-element in question happened to have a consistent series of conjugated double bonds, or some other electrically conducting pathway, then we might well suspect that the postulated captive signal would consist of an *electron* traversing this path. However it seems rather unlikely that these conditions could be adequately met in any realistic system; and<294> there might also be some difficulty in explaining how the electrons could be re-cycled after their transit.]

Accordingly, if there is such a signalling process at all, it seems more likely that we should be considering a captive energy-quantum, and referring to it by an accepted term such as “phonon” (more properly used for relatively homogeneous systems such as crystals), or “exciton” (Burnett, North, and Sherwood, 1974).

Unfortunately, like much of psychology, this individual within-molecule aspect of chemistry is inadequately observable, so it is very difficult to ascertain *in any descriptive detail* just how the exciton is likely to interact with its string of molecular sites. As in psychology, much work has gone into formulating the *manifest behaviour* in formal mathematical-statistical terms; and the success of this ploy for *technological*<sup>60</sup> applications has tended to blind us to our fundamental ignorance about what might feasibly be going on in the unobservable domain. It is, after all, very tempting to hide behind our elegant mathematics and the behaviourist/operationalist premise that the “unobservable” does not exist. Anyhow, it seems extraordinarily difficult to find an expert in this field who is prepared to step beyond what is safely established statistically, and consider hypothetically the detailed nature and behaviour of excitons in such ultra-micro situations. But the present work has frequently encountered this need to postulate a substructure within one “black box” or another, so there seems to be no new reason why the same approach should not be used on the mysteries of fundamental physics and chemistry wherever this seems likely to produce conceptual progress. Meanwhile however, we may happily<295> continue to use the accepted statistical-behavioural concepts whenever they seem adequate for our immediate needs.

<sup>59</sup> Some of these issues have already been discussed in Chapter B2, above; though from a rather different viewpoint. <294>

<sup>60</sup> See the distinction drawn (e.g.) by Bannister (1968) between the needs of Science, and those of Technology: (page 230, column 2). <295>

### A modified analogy to macro waveguides?

Let us suppose then, that the linear molecule will have the same sort of general properties as a more macro wave-guide (such as a non-uniform lumpy guitar string), but with possible additional constraints due to quantum effects. (Quantum theory is part of the cybernetically-unsatisfactory mathematical mystery, as it stands; but we may often let it pass without elaboration as a generally-accepted and useful descriptive formulation). Non-uniformity in a wave-guide will make a considerable difference to its performance — as any dedicated Hi-Fi enthusiast will know. When

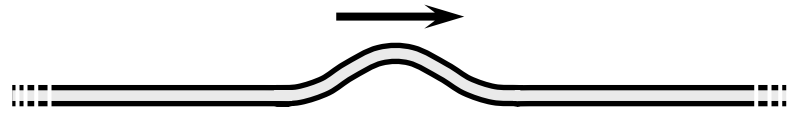

A. Laterally plucked guitar-string

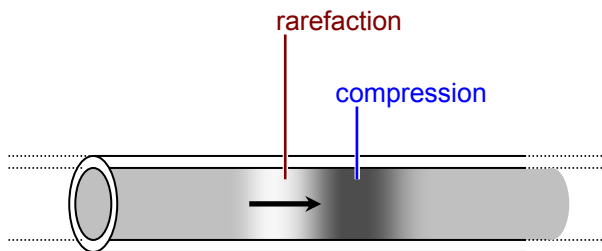

B. Acoustic speaking-tube, or woodwind musical instrument

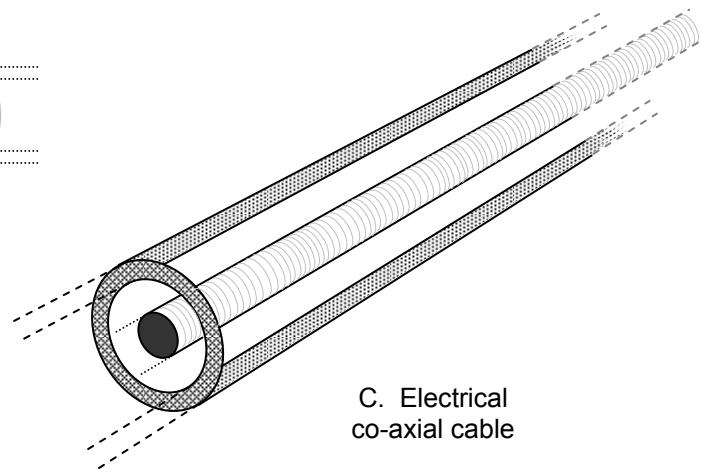

C. Electrical co-axial cable

(296)

Fig C6.7/1. Examples of uniform wave-guides

<296>

the wave-guide is uniform, as shown in Figure C6.7/1, then any established disturbance will propagate at *constant* velocity<sup>61</sup> along the wave-guide — for ever if the wave-guide should happen to be undamped and endlessly long (or looped without violating effective uniformity).

Any discontinuity<sup>62</sup> in such a pathway will tend to cause a *reflection* of the signal back towards the source; and if this reverse-travelling disturbance meets with another discontinuity, then it will tend to bounce back again — resulting in a *standing wave* in between the two discontinuities: see Figure C6.7/2. Thus it is possible to semi-trap the energy of this disturbance between two sites along the linear wave-guide, as well as confining it to the wave-guide itself (a constraint which, in fact, depends on the same sort of discontinuity principle).

298

<sup>61</sup> If the medium is “dispersive”, then each frequency has a separate constant velocity. <296 – (297=figs)>

<sup>62</sup> Also see Karbowski (1965, Chapter 3), Benade (1960), Kinsler and Frey (1962), and Nederveen (1969). <298>

At any point along a wave-guide, and most obviously at any discontinuity, the propagated signal must so-to-speak “decide” whether it will continue on in its present direction, or reverse its direction, or take some other sideways path, or indeed to dissipate itself resistively as heat; or even to suspend itself in storage as if in a wound spring. Moreover different parts of the total signal energy may well be allocated simultaneously to any combination of these possibilities, which may leave us wondering which proportions of the energy will become distributed into each alternative. It is not the purpose of this present work to give a quantitative discourse on the finer points of acoustics; but there are some important *qualitative* details which do deserve clarification, and these relate to the actual micro-mechanisms of the alternatives we have just considered.

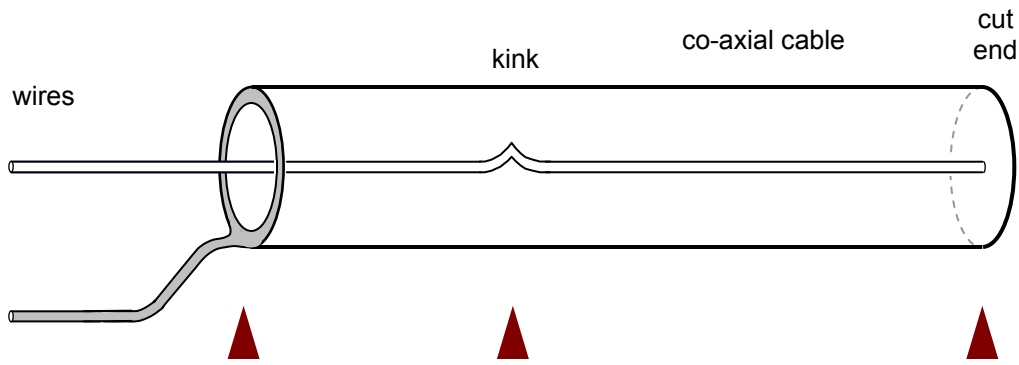
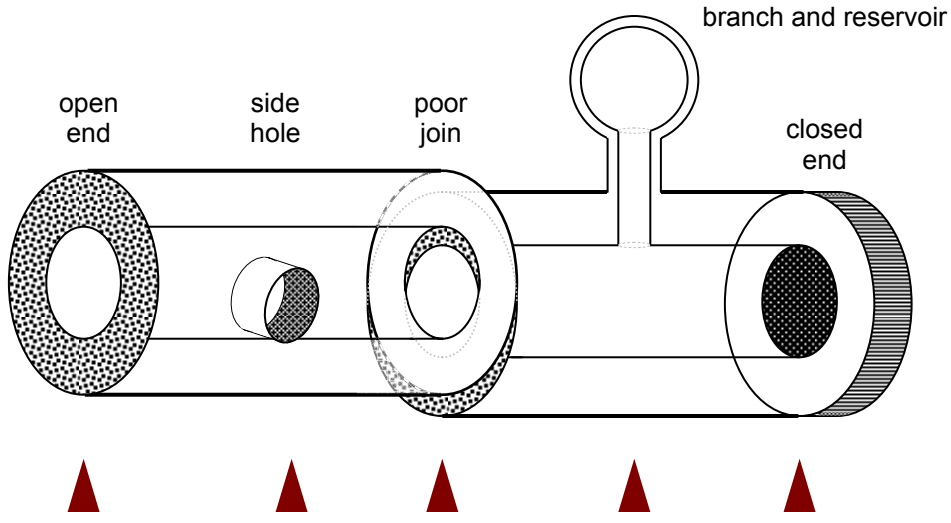
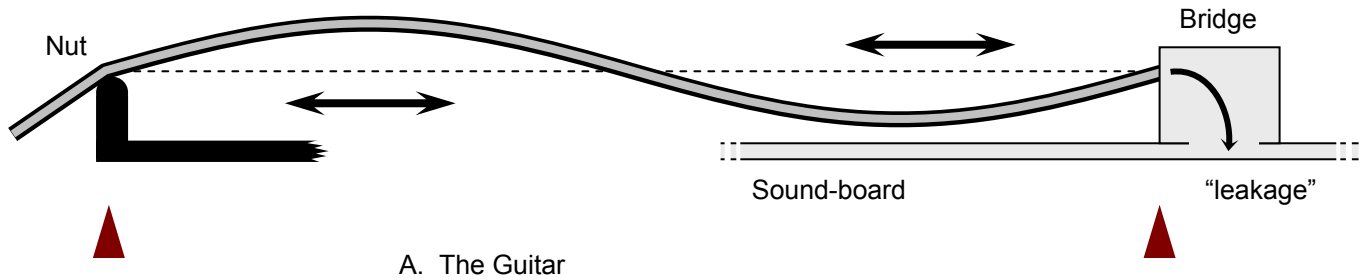

Macro view of molecule-brain system — C6.7 "Mental Energy", Freud etc.

Fig C6-7/2. Examples of non-uniform wave-guides.  
 ▲ = site of reflection or partial reflection, (changes of impedance).

(297)

For instance, let us look at the concept of *resistance*. Here we have “dissipation” of energy into “waste” heat; but what does this really mean? In fact it means a loss of our orderly real-or-conceptual control over the energy of the signal — that is, a loss of negentropy or information. It would seem that such a phenomenon<298> might make sense only when viewed from a comparatively macro viewpoint — and that, by contrast, individual *quanta* of energy would not be able to be frittered away like this in a gradual run-down of energy. Resistance then, would appear to be a statistical “behavioural” manifestation of massed discrete quantum phenomena which are *individually precise* (and possibly even deterministic in a sense — though not experimentally determinable).

299

Similar considerations will apply to the conduction of excitons of energy along linear molecules. Here “energy dissipation” would only have meaning in the more macro context of parallel molecular waveguides which normally operate in a phase-related way. If the signal traversing the different pathways were delayed by arbitrarily differing amounts, then the phase relationship would be destroyed, and the collective more-macro signal would become misdirected into some irrelevant direction — and probably stripped of any message as well.<sup>63</sup>

*{a} If molecular exciton-signals reach specific targets, what “labels” could they use?*

Of the problems raised at the start of this section, the most crucial explanatory task before us is evidently Problem “{a}”: accounting for the postulated specific addressing-code, directed at<299> specific types of element or reception site.<sup>64</sup>

It is scarcely to be believed that a simple allocation of “broadcasting frequencies” would offer sufficient code-variety on its own; so we must look for something which is a bit more sophisticated, and this will presumably entail keylike *patterns* of signal components — probably distributed appreciably in space or time (though not inevitably so as we shall see). In Chapter B2, above<sup>65</sup>, it was assumed that a *time*-distribution would be operating, but let us now re-argue the issues more comprehensively and distinguish three conceivable bases for patterns of signal-distribution suitable for an exciton-molecular system:-

300

(1) The spatially-extended keylike signal may be received as a *space-distributed complex* (which would then presumably have to be translated into internal exciton-mediated activity).

<sup>63</sup> This could occur as a result of the failure of cross-feed coordination depicted in Figure C5.2/2, as it is unlikely that such dubiously-identical parallel elements could maintain proper synchrony without such help — unlike laser-crystals. [In fact it would seem that the criterion for a good optical or acoustical extended *signal-conducting medium*, is that it should display a statistically reliable delay between its absorption of an incident quantum of a given frequency, and its “decision” to eject another such quantum; that this delay value should apply at all such sites throughout the medium; and that these sites should be homogeneously spaced. Thus reliable phase relationships will be maintained. (Also see Stumpf, 1973, Chapter 1).]

<sup>64</sup> Two types of analogy may serve as imperfect illustrations: (i) *Telephone numbers* (and especially *cell*-phone numbers) show the power of using a precisely formulated label-code to home in on a specific target — though that will be a single unique target rather than the here-envisaged *diffuse population target* of unanimous schema-encodings, of which all-or-many would presumably respond to the same “phone number”. Anyhow note that these use a serial *time*-base, like spoken speech. (ii) Traditional *Lock-and-key* mechanisms use matching spatial codes to achieve their specificity — and note that immunological recognition uses the same trick using “lumpy” protein key-patterns. Such coding is obviously in *3D space* rather than time. — [RRT 2006]

<sup>65</sup> As noted earlier, this is now actually in a separate online document:  
[www.ondwelle.com/MolecMemIR.pdf](http://www.ondwelle.com/MolecMemIR.pdf) — See especially Fig [B]2.3/2 for two plausible mechanisms.

Receptors A and B, perhaps placed a significant distance apart, could each be activated simultaneously by their respective frequencies or other parallel stimuli. Consequently they would then each pass on an internal exciton toward an *and*-gate within their common molecular structure, such that if-and-when the two excitons reached the *and*-gate together, a further internal signal would be passed down the effector or “program” segment — and the reception process would have been completed. Unfortunately however, given the likely frequencies (with wavelengths > 1 μm), it is difficult to see how A and B could be a “significant distance apart” (compared to the 1 μm) and yet still be sufficiently in touch via *intra*-molecular communication-channels. Such a model could still be of some service though, if we drop the requirement for A and B to be so far apart, and instead use it as one possible device for solving case (3), below.

(2) The signal may be treated as a *time-distributed complex of discrete quanta forming an identifiable time pattern*<sup>66</sup>. Here we can envisage an initial stimulation of receptor A which sets up an internal exciton-signal. Further progress will then presumably depend on the more-or-less precisely-~~300~~timed arrival of a correctly-tuned signal at receptor B, and another at C, and so on; (Traill, 1976b; and Chapter B2 above<sup>65</sup> (alias Traill, 1977)). There seems to be no obvious objection to a system such as this, and moreover it is easy to see how the appropriate time-pattern of signals could arise — through the optical dispersion of the various Fourier components of an initially integrated pulse or other disturbance *having a quite specific shape*. Such dispersion could be particularly pronounced in myelin wave-guides, (Chapter B4, above — *ibid.*).

(3) The specificity of the signal might lie in its “*shape-as-such*” as a *composite irregular pulse or wave-packet*<sup>67</sup> on arrival at the receptor, where this implies a signal time-span comparable to the period of component frequencies.

This pulse-shape modification rather presupposes *populations* of supposedly-unison photons, and hence a move toward the macro-effects of everyday life. (After all, the wave pattern within an individual photon cannot be “bent” in this way!). The FM or AM coding of radio signals would serve as a close analogy, but we have to be careful not to import such notions into isolated ultramicro quantum situations.

#### *Optical dispersion — its constant modification of signal shape-and-timing*

In view of the likely prevalence of dispersion, it is doubtful whether any emitted pulse or disturbance could maintain its shape<sup>68</sup> until it reached a site which was realistically remote. However it should be noted that there is no requirement that it should be the *same* shape as when it started; it is merely necessary that it should have *a* characteristic shape by the time it is received — and possibly different characteristic shapes for different receptors (where the same signal is likely to be used at different sites). [...<sup>69</sup>]

<sup>66</sup> (e.g. a coordinated volley of well-separated quanta; *i.e.* with each pair having a time-span between them which is appreciably greater than the period of individual component frequencies, as illustrated by the *last sketch* in the New Figure C6.7/2a below). The original 1978 sentence (black text) here singled out this special “well-separated” case. However that was being overselective: Overlapping or even simultaneous quanta can also be included here — *as long as they are not truly interacting* before they reach their target. (That is the unlikely “(3)” case, which we will briefly consider next). [2006]

<sup>67</sup> odd shapes like the (omitted) *sum-curves* for first three sketches in New Figure C6.7/2a — see below.

<sup>68</sup> Here we take the *wider interpretation* of “shape” — including *time intervals between* logically-related photons (“case (2)”) — as well as the more obvious but sometimes-questionable shaped-pulses of “case (3)”

<sup>69</sup> [Sentence deleted as irrelevant and confusing. : On the other hand though, this will not help much if dispersion has actually “dismembered” the signal into its component frequencies, as required for “(2)” above; and it seems quite likely that this is what will normally happen. — RRT, 2006]

Nature has a way of capitalizing on odd effects like this. One possibility here is that this constant *reproducible-and-predictable* “translation” of signals as they travel along their optical path will make it easier for *some* receptor, *somewhere* along the path, to establish meaningful communication — partly by Darwinian trial-and-error. We will return to this idea below in the subsection “Fixed-range signals” below (o.p.304), and in New Figure C6.7/2a.

#### *Meaningful signal-combination from two sources simultaneously*

But there is yet another twist to this question of remote shaped-patterns, and that is that they might arise in a barely-predictable way from the interaction of signals in the presence of a receptor competent to “capture” an ephemeral pattern — a pattern which would normally disintegrate without trace.

A simple way of detecting coinciding signals like this would be • just to receive each one individually, at closely situated receptors such as those suggested at the close of “(1)” above, and<301> then let the separate resulting *intra-molecular* signals interact via some suitable *and-gate* arrangement. The question of external interaction of the signals themselves would therefore not even arise in this case, and indeed the arrangement turns out to be very similar to that of “case (2)” — differing mainly from the Fig.B2.3/2 versions in its apparent lack of internal “delay units”, so that it would appear to be merely a special case of the latter.

302

If we are looking for a fundamentally different alternative mechanism, then we must apparently grasp the nettle of • selective interaction at the receptor itself, and contemplate such questions as: how it might *simultaneously* cope with two incident quanta; what (unobservable) structural changes might be involved internally; and just how strictly simultaneous, and geometrically-arranged the coincidence of the quanta would need to be. For instance it is conceivable that the polarization of the two quanta should be more-or-less perpendicular, the trajectories should perhaps be at about 70°, and maybe the peak amplitude of one of them should arrive at about 5 picoseconds before the peak of the other ( $\pm 2$  p.sec.).<sup>70</sup>

#### *Suggestion for deeper investigation of exciton interaction*

No further attempt will be made here to explore the feasibility of these mainly-external types of interaction, but perhaps some remarks about how to approach the problem would be appropriate. Probably the main need is to analyse, in as much *structural* detail as possible, the intricacies of the *process* of ordinary single-quantum absorption into atomic and molecular orbitals. Even though no hard experimental evidence will be available for establishing the nature of the dynamic sub-structure, this should not be allowed to halt the programme while there is still plausible progress to be made using internal-closure principles for investigation — on the reasonable assump<302>tion that the real system must have group-like properties if it is to sustain itself cybernetically. (Of course such model-building should take full account of accepted formulae and formulations of physics, though without necessarily accepting their implicit assumptions on such matters as causality). Depending on the degree of success with such a programme, it might then be comparatively easy to extrapolate — more or less convincingly — to cases involving transient phenomena *and* multiple incident photons. One might even come to some (partially) testable hypotheses leading perhaps to a (partial) justification by traditional criteria. This amounts, of course, to advocating a reductionist programme in physics along the lines that the present work is attempting to apply to psychology.

303

<sup>70</sup> Fortunately, we can probably ignore the totally heretical idea that the two quanta might coalesce just before reception: the case of pure interaction!



### Other applications for signal-combination?

Before leaving the inconclusive “case (3)” concerning the *shape* of signal pulses, let us look briefly at what implications would be likely to follow on from such mixing of signals from different sources. To start with, it would not be much use on its own for the type of specific name-calling envisaged in the theory of sets and groups developed in connection with the postulated **M<sup>n</sup>L** hierarchy. It might however, conceivably play a useful auxiliary role by governing which elements out of the many would be available “on call”, and which should instead remain dormant for the time being. Perhaps this might express particular moods or sleep modes, or ensure a balanced “randomized” access amongst the roughly equivalent alternative target elements (by making any individual element accessible only if the “spotlight” happens to be pointing in its direction) — though this would seem to be a particularly cumbersome way of achieving such a straightforward objective. Nor is there anything very convincing about the mood/mode suggestions unless we can envisage some reasonably accurate way of directing these auxiliary signals to specific<303> target-areas: either using the call-sign principle (which simply takes us back to the use of “case (2)” above — time distribution), *or else* as an agent of locality-based “extensive definition” of elements.

If simple extensive areas are all we are concerned with, then this device would seem to be rather superfluous since we could arguably just make do by having a limited range to our signals and concentrating our target elements within this range. However it may well be that complex and variable extensive-regions will be required — for hologram storage perhaps (Pribram, Nuwer, and Baron, 1974; Pribram, 1971) — so there may well be important uses for such phenomena. Nevertheless we must remain in some doubt as to whether they are even feasible; and anyhow the “case (2)” paradigm seems to be the most promising explanation of how “intensive definition” naming would operate, so we may provisionally accept *it* as the norm — while bearing in mind the possibility of these other additional mechanisms.

### Fixed-range signals

There are also some implications arising from “case (2)” which are worth considering, and which might even be testable in an orthodox experimental way! If the original signal disturbance-shape is continually being modified by dispersion as it progresses away from its source — becoming ever more spread out in its spectrum of Fourier-components, then we might obviously expect that the ability of a receiving mechanism to recognize it will probably depend on its being at the correct range away from the source: neither too far away *nor* too close (see New Fig. C6.7/2a). This phenomenon could do much to ensure an adequate spread of signals, so that they will not generally be intercepted prematurely by nearby receptors — with which the emitter might well have an internal link anyhow. Or to put it another way, it suggests a rather special communicational topology which might profitably be investigated from a mathematical point of<304> view; and at a more everyday level we might well contemplate the implications of the Knight’s move in chess!<sup>71</sup> (Also see Figure C8.1/7, below). (Of course, on a larger scale, nerve tracts also achieve a similar non-Euclidean topology).

A further implication arising from this is that a change in range might mean that a given signal will now be interpreted differently: the meaning may thus be locality-dependent — like the word “pavement” considered separately on each side of the Atlantic. It would follow from this that effective “mutations” of elements could occur if-and-when there were a substantial movement in the location of receiving-elements, or of the emitting-elements — or indeed if there

<sup>71</sup> At one extreme the chessboard King can move only to adjacent squares, and at the opposite extreme the Queen can move right across the board if there are no obstacles. *Between these* we have the Knight which can move only to certain *intermediate-distance* squares, all at the *same restricted radius*.

were a significant change in the optical path between them, reversibly or irreversibly, spontaneous or “deliberate”. There would thus be some scope here for pathogenic or therapeutic pharmacological intervention, though on the whole such effects seem more likely to operate on the acoustic paths which we have been supposing to operate along the molecular structures themselves. It is to these acoustic paths and their likely control mechanisms that we will now return.

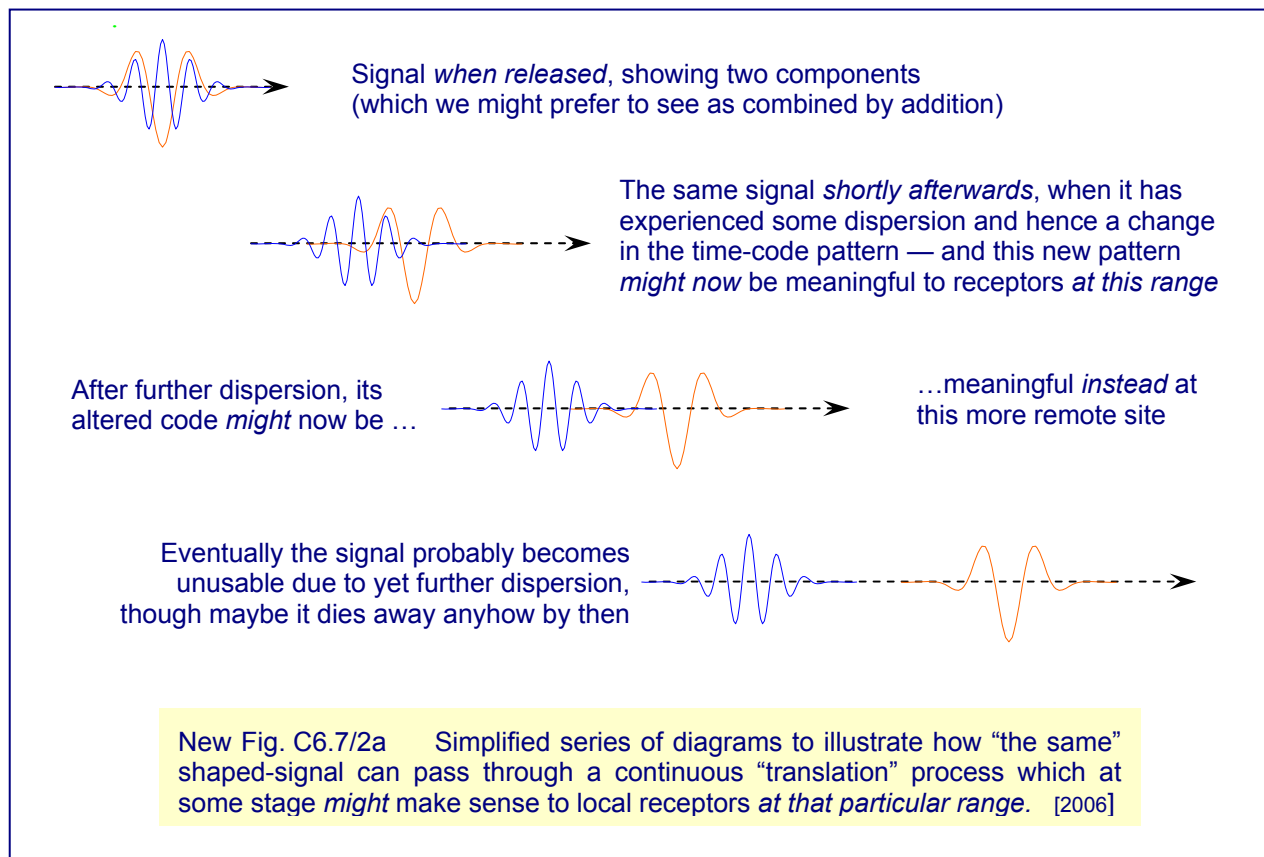
added  
2006

Macro view of molecule-brain system — C6.7 “Mental Energy”, Freud etc.

### *Molecules as waveguides and logic units*

Figures C6.7/1 and C6.7/2 drew attention to the nature of wave-guides in general, and served to introduce the idea that linear molecules might also be viewed as wave-guides — though subject to manifest quantum constraints which would not be apparent in more macro systems, where individual quanta would be hidden amongst a statistical population of fellow quanta. From there we went on to examine a variety of technical difficulties related to systems of this sort. Having done that, we should now go back to the main theme of molecules-as-waveguides and consider how reflections and storage might be expected to influence the progress of excitons along the molecule; and also<305> look at how such potentially logic-gating mechanisms might be influenced from outside the molecule.

306

Following on from the work of McCulloch and Pitts (1947; McCulloch, 1950) and elaborations by Hebb (1949), there was considerable discussion until the 1960’s of the supposed role played by neurones as logic elements or “formal neurones”; (Blum, 1962). Clearly there is still much to support the idea that interaction effects such as summation do occur at neural cell-bodies and other sub-synaptic sites (Eccles, 1964; Katz, 1967 ) and *perhaps* there is no need to enquire any further in the case of “simple” behaviour, such as in invertebrates, though this is highly debatable (Miller, 1970). But such formulations do not, by themselves, explain how transmitted messages interact with chemical “transmitter-substances”. Moreover the more recent ultra-micro

studies have shown that neurones are generally much too complex to be adequately modelled by simple binary logic elements — even as a rough approximation — nor by ternary logic elements (Traill, 1970); or even logic elements with any number of straightforward on/off inputs. On the other hand though, it will now be argued that mechanisms roughly approximating to such binary elements could well be found at the molecular level — in keeping with the ‘linear micro-element’ theory of mentation. It might therefore be possible to update some of the earlier “formal neuron” theory on these lines, though no attempt will be made to do so here. Moreover it is rather difficult to see how the “plastic properties” of neurones (Bureš and Burešová, 1970; Lippold, 1970; Spencer and April, 1970) and the consolidation of Short Term Memory into Long Term Memory (Griffith, 1970) could be properly explained without going into detail of this sort.

There are 16 mathematical operators for binary logic, (Blum, 1962). Each determines whether the “result” will be *on or off* (306) (“true or false”) — given its own particular pattern for the on/off-ness of two independent inputs A and B. Thus “ $X = A \text{ or } B$ ” will mean that X will be “on” for the three cases:-

- (i) Both inputs *on*;
- (ii) A = *on*, B = *off*;
- (iii) A = *off*, B = *on*;

but that X will be “off” for the fourth case:-

- (iv) with both inputs *off*.

Of the sixteen patterns, only ten are truly two dimensional in the sense that the result really depends on both A and B. Four of them will be entirely determined by the state either of A or of B, (one-dimensional); while the other two are entirely independent of both! (zero dimensional). These latter six cases are thus “degenerate” or trivial from the two-dimensional point of view, and so cause less difficulty in explanation. Other cases are of somewhat improbable utility at molecular level, and can anyhow be manufactured from multiple use of the others if all else fails. For example:-

(A and not B) or (B and not A)

It will therefore suffice here if we look mainly at the following four:

*and*, *or*, (A and not B), (B and not A) —  
with some brief mentions of the trivial cases.

To set the stage, we shall take it that we are considering a linear molecule with side-chains, each potentially capable of *picking up* a photon from outside the molecule, or *emitting* such a photon, or storing quanta of energy as a local excitation state — presumably entailing some sort of structural change relating to itself, and this might or might not affect the energy-handling properties of the system. Let us define A to be an exciton travelling down the main chain from the molecule, in the “correct” direction; and B as the exciton arising from a newly captured photon (or from 307 storage) — where the new photon approaches the main chain via a side-chain. These may then interact directly, or affect each other indirectly by changing the configuration of the system.

Molecular “and”-gate

Consider now the properties of a non-uniform molecular waveguide in this context. What would be merely partially-reflecting obstacles in any macro-system, are here likely to be totally reflecting due to quantum considerations (probably entailing group-like configurations involving the molecule itself) — thus effectively trapping the first exciton-signal, be it A, or B. This trapped<308> state could then be relieved by the arrival of the other exciton of the pair — raising the local system to a higher energy state which could thereby pass the threshold of the quantum-barrier and so generate a further exciton-signal moving down the next section of the molecule, and/or emitting a photon capable of influencing other such molecules. This mechanism would thus constitute an “and-gate”; see Figure C6.7/3.

309

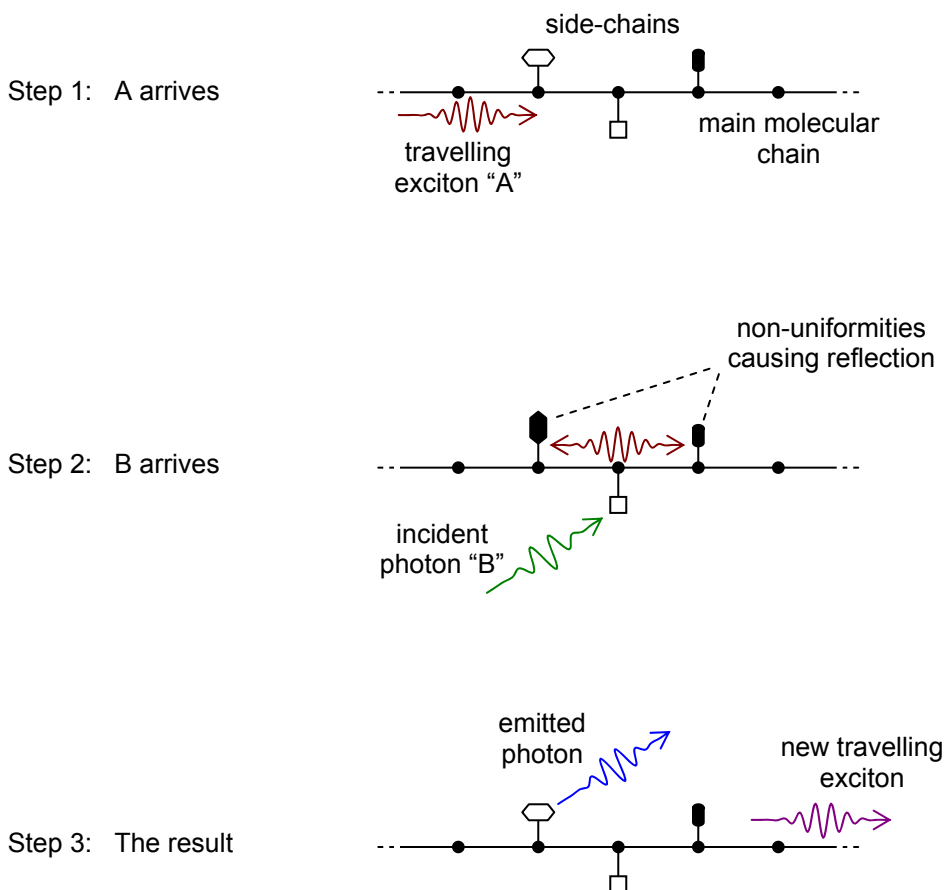

Fig C6.7/3. One possible molecular embodiment of an *and*-gate, with the following logical properties:- ...<308>.....

	A	not-A
B	act	
not-B		

Macro view of molecule-brain system — C6.7 “Mental Energy”, Freud etc.

Molecular “inclusive-or”-gate

The construction of an *or*-gate would be somewhat simpler as we can now dispense with the reflection-trapping mechanism — accepting the “new travelling exciton” as a direct consequence of either the old one (A), or of a newly received photon-signal (B). In the improbable event of *both* arriving simultaneously, several different things could happen. The incident photon could be re-emitted, giving an inclusive-*or* as shown in Figure C6.7/4 — though<309> this re-emission might be delayed, leaving a possibly changed configuration in the meantime. Perhaps there would be interference such that there would be *no* resultant travelling exciton — giving a case of “exclusive-*or*” from the molecule’s point of view — though there would presumably be other alternative outputs such as photon emission or a *backward*-flowing exciton. Alternatively we might obtain a *qualitatively different* resultant exciton which is otherwise orthodox — a sort of super-positive response (from the molecule’s viewpoint), of which arithmetical addition of energy-values would be a special case.

310

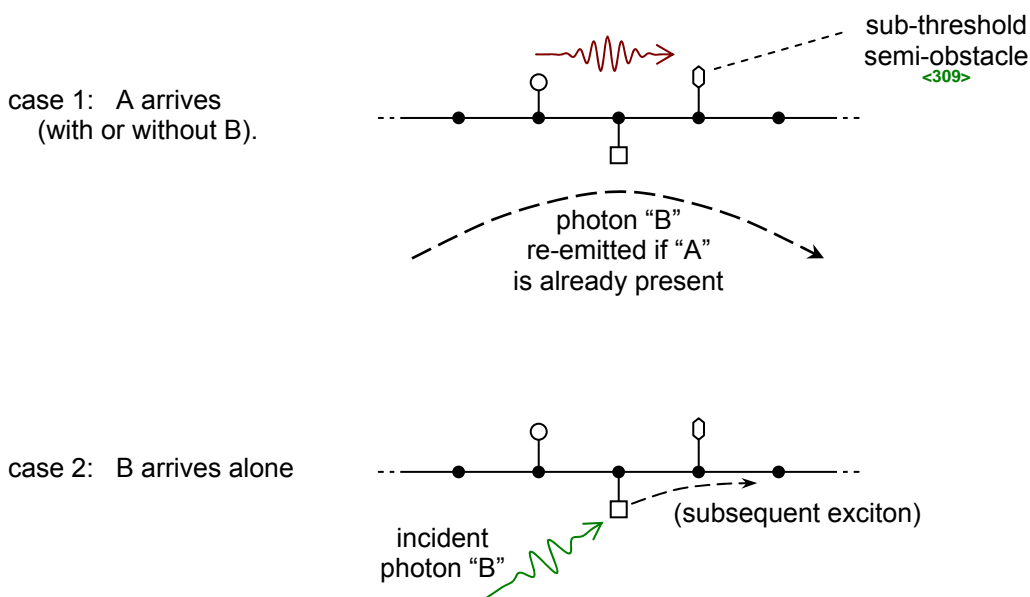

Fig C6.7/4. One possible molecular embodiment of an inclusive-*or* gate, with the following logical properties:-

	A	not-A
B	act	
not-B	act	

(309)

Macro view of molecule-brain system — C6.7 "Mental Energy", Freud etc.

Two different Molecular “not”-gates

Systems involving the concept of “not” may be explained in terms of configurational changes which are caused by the “negating<310> signal”, and which have the effect of blocking or sidetracking the other signal. Thus Figure C6.7/5 represents the “A and not B” case, and the situation for “B and not A” can be depicted as in Figure C6.7/6. <figC6.7/6: 311>

311

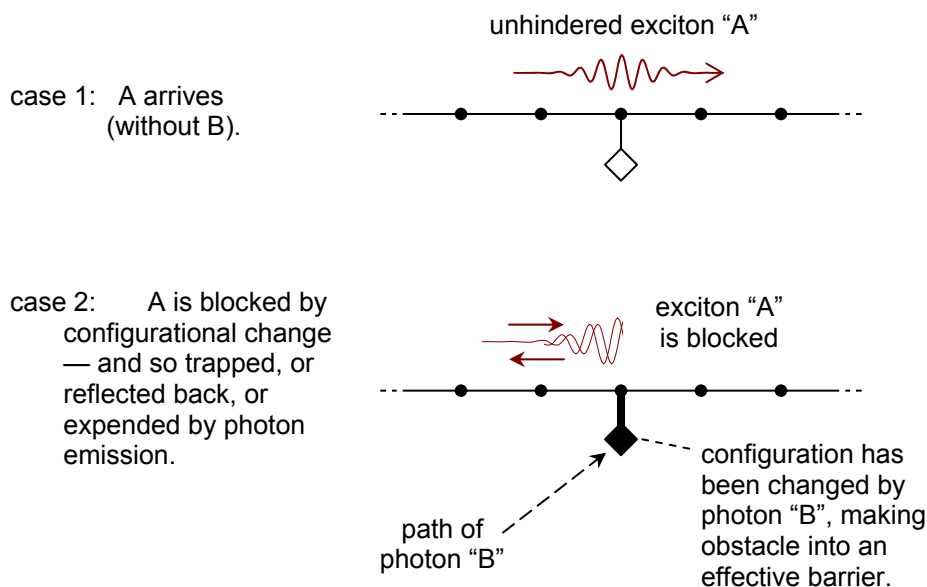

Fig C6.7/5. One possible molecular embodiment of “A and not B”, i.e. the logical condition <310>depicted by:-

	A	not-A
B		
not-B	act	

(310)

The latter case, whether or not this arrangement actually occurs in nature, at least serves to highlight the possibility that the system might respond unexpectedly selectively when faced with quanta having differing energy-values. In the example shown, it was the lower-energy signal which was diverted by a “high-pass filter” (so that it ended up doing switch-throwing work, rather than continuing as a signal in its own right); but it is also conceivable that a “low-pass filter” in the same position could<311> similarly divert a higher energy quantum into the role of switch-thrower for a lower energy signal. And this would be a rather more surprising phenomenon, though the idea that the uniformity-or-otherwise of the waveguide will depend on the signal-frequency, is a commonplace of electronics. Thus the degree of reflection at the discontinuities in the wave-guides of Figure C6.7/2, will depend very much on the frequency or transient-properties of the disturbance being propagated; so that, for certain conditions, some of the discontinuities will “pass unnoticed” as far as that particular signal is concerned. Whether such selective treatment occurs much, or at all, at the postulated molecular-pathway level, is rather a moot point; but there must presumably be some provision for signal-sorting *somewhere* in the system, be it in molecular activity, or nerve-fibre optical dispersion (Chapter B4, above), or both, or whatever. At cell-level, at least, there is evidence of a comparatively macro type of signal separation;

312

Macro view of molecule-brain system — C6.7 “Mental Energy”, Freud etc.

Situation 1: <311>  
B arrives (without A).

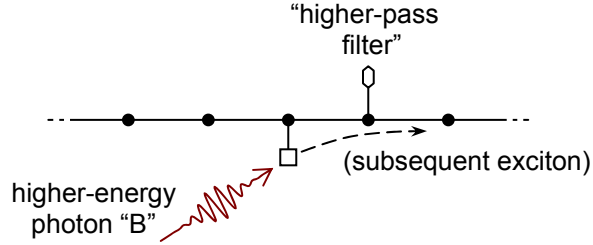

Situation 2:  
A, obstructed by  
specific filter, is  
diverted into B's  
receptor.  
This changes the  
configuration as  
long as it stays stored  
there — thus blocking  
B.

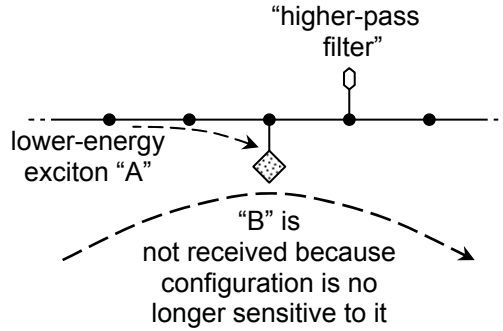

Fig C6.7/6. One possible molecular embodiment of “B and not A”, with the logical properties:-  
.....

	A	not-A
B		act
not-B		

(311)

(Hughes, 1965; Chung *et al.*, 1970; Waxman, 1972; Grossman, Spira, and Parnas, 1973; Goldstein and Rall, 1974).

Trivial logic-cases

Of the trivial or “degenerate” logical functions, we might just note the following examples. (1) *A regardless of B* is obviously just normal transmission along a wave-guide, without obstruction or qualification. (2) *B regardless of A* is reception of a photon without any influence from any incumbent exciton — at the start of a “label” for instance. (3) “Contradiction” is a dead-stop with no (within-molecule) output — though presumably we may allow it to be a photon-emitter to dispose of its acquired energy — or perhaps it will do so by back-reflection or other such complicating action?

The implication here in “(3)”, and in Figures C6.7/3 and C6.7/5, that there might be important outputs expressed as photons emitted <312> into the exterior, or reflections sent backwards along the molecule, once more calls into question the value of categorizing such phenomena in terms of the sixteen binary operators — even though they have now apparently been rescued from their embarrassing inapplicability for normal neurons. If such a mathematically-oriented formulation is called for at all, then we would seemingly need a system which contemplated: two or more different types of output; storage and its likely configurational changes with varying stability;

313

and also the constraints imposed by the *conservation of energy*. Such a calculus might eventually be forthcoming, but meanwhile we would do well to keep to first principles or else cautiously use a hybrid pluralistic formulation.

### *Implications for Freud's vague theory on "Mental Energy", etc.*

We are now in a position to offer some new comments about how pharmacological chemicals might operate. There has long been considerable evidence that many of them are site-specific; thus it does not take much imagination to see such additions as new components in the "wiring" of Figures C6.7/3 to C6.7/6 — either as configurational changes comparable to those supposed to arise from the storage of excitons, or as entirely new "electronic components" which create, modify, or abolish reflecting-discontinuities and any frequency-selectivity which they might have. Of course many such chemical agents occur naturally, as neurochemical transmitters or whatever; and it is well known that the effectiveness of some exotic agents lies in their ability to compete for site-occupation with the "normal" occupants of those sites. There is no obvious reason why these sites should not be the linear-molecule sites postulated here; though of course it is not suggested that there is any direct current evidence to support this notion.

The psychoanalytic theoretical literature is replete with concepts involving the blocking of mental "discharge", though it <313> has never been entirely clear just what, in material terms, is being blocked or discharged. Thus Fenichel (1946, page 11) writes:-

"The basic pattern which is useful for the understanding of mental phenomena is the reflex arc. Stimuli from the outside world ... initiate a state of tension that seeks for motor or secretory discharge, bringing about relaxation. However, between stimulus and discharge, *forces are at work opposing the discharge tendency*. The study of these inhibiting forces, their origin and their effect on the discharge tendency, is the immediate subject of psychology. Without these counterforces there would be no psyche, only reflexes [Ferenczi (1926)]." — Emphasis added.

In the absence of any precise idea as to what is meant by such terms as "forces at work", or "discharge tendency", or even "reflex arc", it is something of an effort to take seriously the notion that our mental propensities should be considered as channelled-energy or forces within our brains (except as a metaphorical analogy). Nor, given the accepted view of (*fuzzy*) logic at cell or synapse level-of-resolution, can we really very credibly explain how a *specific* blockage could be set up and *maintained*. However the above exposition in terms of quantized molecular phenomena does seem to offer the basis for just this sort of precision and specificity. In particular, the problem of how to cope with blocked "A" excitons and their energy, has arisen as an explicit issue in connection with Figure C6.7/5. Accordingly, it may now be within our grasp to define Freudian "mental energy" in reasonably precise physical terms — presumably involving quantum energy, or its entropy given the collective state of synchrony between molecules, or both.

By the same token, it should now be possible to be more explicit about "mental economics" and the closely related notion of mental exhaustion (Fenichel, 1946, pages 13-14). Qualitatively this has always been a plausible idea once the "energy" concept <314> has been accepted, because energy or negentropy must ultimately be supplied from limited resources and be directed along routes with limited channel-capacity. The latter would now seem likely to be quantifiable in terms of molecular acoustics, and nerve-fibre wave-guide properties (Part B, above); while quantitative approaches to questions of energy-*source* have been suggested by Cope (1973) — involving the storage of infra-red quanta in mitochondria, after their generation via redox potentials. <315>



## Chapter C7

**MECHANISMS FOR NEUROSES**

316

## SUMMARY OF CHAPTER

Here structural bases are proposed for various Freudian “defense mechanisms” in terms of the details postulated in Chapter C6. This leads to a provisional formulation of the distinction between neurosis and psychosis in terms of their structure, rather than the usual behavioural approach.

**C7.1 What are the “normal” adaptive responses to frustration ?***Coping with frustration — good homespun advice, and beyond*

Is there any general advice one could give about how to cope with frustrating situations and dilemmas? Alcoholics Anonymous has, if memory serves me correctly, offered several items of advice in the form of a prayer for the following virtues: **(i)** the strength to change what I can, [presumably toward the solution of “dissonance“]; **(ii)** the serenity to accept what I must; and **(iii)** the grace to know the difference. As far as it goes, this is probably sound enough.

However if we want to go more deeply into this matter, we might well inquire whether we can choose an optimal-though-imperfect solution to the dissonance. This then raises questions about time-horizons and chances of “success”, and to what extent our “solution” is *fundamental* rather than merely papering over the cracks by treating the symptoms.

*Mechanics of changing one’s frustration-reduction strategy*

Faced with genuinely insurmountable frustration, it is obviously an adaptive procedure to “give in” and “accept the situation”; but what is this likely to entail in mechanistic-physiological terms? Such a change may be likened to the election of a *new* government, thereby discarding the old policies which had proved to be a failure in practice despite any dreams of Utopia which they might have conjured up. Where basic hereditary instincts <316> are involved, this creates a special obstacle to “policy-change” because further scheme-elements of the original pattern are likely to continue to appear on the scene as fast as their genetic sources happen to reproduce them, (Section A3.2, above). Assuming that the genetic ( $M^{-1}L$ ) sources are immutable within the individual, it would nevertheless be feasible for the brain systems to evolve a more-or-less standardized procedure for supporting particular types of mutation in these elements, and discouraging the use of the unmodified varieties. Thus such primitive reflexes as the palmar reflex quite soon become “swamped” in amongst later complexities, and it may even be that the later developments will have “switched off” the genetic sources, to a greater or lesser extent. Anyhow, these alterations to the effective expression of basic instincts may be identified with the Freudian concept of *sublimation*, (Fenichel, 1946, page 141).

317

Although these fundamental changes in aim will be away from hereditary instincts, they should nevertheless be regarded as “natural” in the sense that the genetic code has evolved in such a way as to take account of developments of this kind — which is simply to say that they are orthomaturational. This is, in fact, another example of the fact that the genetic code could not possibly foresee all eventualities, nor could it reasonably encode all the relevant “legislation” even if it could foresee the needs. Anyhow, the resulting mutated elements will be capable of operating in an orderly and adequately efficient manner, without any undue build-up of undischarged excitons which might break through in uncontrolled ways. Moreover the resulting aims are often likely to be vitally important to the individual himself, and even more so to any complex society in which he lives. The fact that different individuals will evolve different

solutions will also be valuable in producing <317> that pluralism which makes for a particular aspect of social stability.

Other types of mental change will also be called for when one's non-hereditary *learned* mental constructs turn out to be at variance with reality in important ways. Ability to accommodate to such situations — to allow competitive structures to evolve at the expense of the old ones — will depend partly on how pluralistic or “broad-minded” one's mental organization happens to be (and this may well depend on uncommitted mental energy), and partly on the clarity of insight at higher M<sup>1</sup>L levels.

But not all frustrations are necessarily insurmountable. The adaptive approach in such cases is obviously to try to mould the reluctant environment so that it more fully accords with one's own will; where we may take “will” to include unsublimated instinct (including the important case of seeking-for-closure), and also the aims which will so far have arisen from any sublimation. It is, of course, this striving after one's grand-or-trivial objectives which is the driving force behind mammalian endeavour; and arguably it also drives all endeavour of all animals. When such attempts are chronically frustrated without sufficiently-redeeming sublimation, then less satisfactory methods involving such things as signal-blocking will come to be used extensively, instead of just as short-term expedients. These are the “pathogenic defenses” (Fenichel, 1946, page 143 ff.), resulting in neurotic symptoms such as depression and loss of morale. For the remainder of this chapter, we will devote ourselves to considering various types of such “defense”, and sketching the sort of mechanism which might plausibly be involved. <318>

## C7.2 Denial as “hallucinatory wish-fulfilment” for some part of the situation

### *Denial, fiction, and ego-protection*

As adults, we usually have fairly definite ideas about what is fact and what is fiction. We may choose to mislead others about the truth, but it is often supposed that “mentally healthy” adults will not *really* be taken in by their own fabricated propaganda — at least not much! In so far as we *are* able to keep control over such matters, we are probably making use of M<sup>2</sup>L constructs — possibly including accumulated extensive-sets of “facts” and of “fictions” relating to various topics. But any such established sets must have been created in the first place, and this almost certainly will have occurred on the basis of experience and closure-forming processes. Thus in childhood, before such developments have taken place adequately, any sense of reality will quite likely depend on *ad hoc* assessments of closure — subconsciously weighing the closure-implications of various concepts, with particular attention to any bearing they might have on the self-consistency of one's own ego-supporting schemata. It would thus scarcely be surprising to find young children really believing that *they* “didn't break the dish” (or whatever). And, to the extent that adults will suffer from lapses in rational M<sup>2</sup>L control, we may expect similar self-deception in them too.

### *Denial versus evidence*

Almost inevitably however, there will be inconvenient self-incriminating evidence left around to disturb the equanimity of those prepared to assimilate it properly. (In the child, this might perhaps cause no great problem if he is *unable* to attend adequately to enough of the evidence simultaneously for him to detect the overall lack of closure, even if he were prepared to do so). But if the child or adult *is* subconsciously aware<sup>72</sup> of the <319> cognitive dissonance choice, and if it amounts to a stark choice between • maintaining the integrity of his own ego by blocking the unwelcome evidence, or • badly eroding his ego-complex by accepting the closure-destroying

<sup>72</sup> At the M<sup>1</sup>L level, perhaps? <319>

information, then it will not be surprising if he chooses the former (**ego-preserving**) course. Usually however, there will actually be other alternatives open to him (if he is both aware of them and able to cope with their internal manipulation): He may, for instance, invoke the proposition that “This was just a mistake, and everybody makes some mistakes”, or he may incorporate the evidence *into* his ego-schema and thus take on the new role of “a bad guy”!

#### ***“Freudian energy” needed to maintain the denial***

However, if the choice is made (subconsciously) to block the evidence as being “against self-security”, then presumably some sort of “jamming” signal will have to be found which will block the excitons in the pathways in question. This is likely to operate as depicted in Figure C6.7/5, with the consequent damming up of unwanted excitons which will not just conveniently fade away and are always likely to break out in one form or another as long as they are stored in this manner; so there will need to be a continual expenditure of energy to maintain the damming, as long as the threat persists or seems to persist.

There remains the problem of how the appropriate method for jamming could have been produced as soon as it seemed to be needed. The answer is likely to be that this could *not* be done intentionally without prior experience, and that this earlier investigation would have happened quite spontaneously and arbitrarily like other initial learning, with at least some of the relevant references stored away for potential future use. <320>

### **C7.3 Projection and introjection as by-products of the self-organization of the ego**

321

#### ***Ego — the formation of a very specialized schema***

Fenichel (1946, page 40) writes enigmatically that “Introjection is an attempt to make parts of the external world flow into the ego.” Similarly projection is seen as an attempt to attribute ego qualities to entities other than the ego. Moreover it is suggested by him that there is a stage of development ... “in which anything unpleasant is considered nonego, [and] anything pleasant is considered ego”. How then are we to formulate these ideas in terms of the current theory?

Back in Section C2.3 and the latter part of Section C5.2, we considered some of the likely features for the formation of extensively-defined sets within the material substrate of the brain; and it should be noted that an important aspect of this supposed procedure was that the *initial criterion* for the membership of such sets was envisaged as being *arbitrary*. This concept of set-representation was developed, via “groups”, into an explanation for *object*-representation — of which the “self-concept” or “ego” was held to be a very special case (Section C6.3, paragraph 6). At the same place, it was suggested that the most crucial criterion for a set of “self“-concepts would be whether the candidate-features responded readily to one’s own will (hands, tongue, etc.) or whether they were comparatively dilatory in this respect (Mummy, chair-leg, etc.). But such response to one’s whim is likely to be regarded as “good” if only because it will probably aid closure-formation, a process which we are taking to be inherently rewarding, (Paragraph 5 of the same section). So, even if this reasoning is only partly valid, there is some reasonable justification for adopting the implicit slogan: “Whatever is pleasurable, is something which belongs to this whim-serving set/group which represents an object called ‘me’.” <321> That is to say, as a *first approximation*, the criterion of pleasure-serving is not so very different from the criterion: “this autonomous integrated system, subservient to my will, and possessing privileged information-gathering properties”.

322

#### ***Loose mind-metaphor terminology — versus clear (more testable) statements***

As for Fenichel’s words about attempting “to make parts of the external world flow into the ego”, this is obviously meant metaphorically or “mentalistically” (Hyland, 1977a, 1977b) since a

literal “physiological” interpretation seems to signify a craving for brain-surgery! The intended meaning (in terms of the current theory) would seem to be something like this:-

“Introjection is an attempt to incorporate *the schemata for* various parts of the external world into the schema which constitutes the ego”; (presumably without unduly disturbing the grouplike properties of the latter).

Such confusions between the “real” outside phenomenon and its “mental” counterpart are common enough, but now that we are getting down to more precise (if speculative) statements, it is time to be more careful over such wording — and to avoid unexplained metaphor in our main pronouncements.

#### *Seeking to explain projection etc. via set-dynamics — hence via molecular dynamics*

Anyhow introjection and projection, like denial, may readily be seen as arising naturally from primitive set-manipulations which involve the ego. Given unsuitable experiences and/or inadequate “decentering” to take in a comprehensive sample of the features of such experiences (due presumably to deficient  $M^1L$  organization at the next higher level), such merely-approximate strategies may become adopted as being (apparently) the optimal solution. They may then acquire their own system of self-stabilizing closure (based on the spurious evidence) and it will then be quite difficult or impossible to unpick the structure — or at least to do so without also breaking up the ego-structure, especially if this now depends on inappropriately introjected schemata to maintain its own closure. <322>

#### **C7.4 Repression as an internally-directed equivalent of denial**

It was suggested, in the closing two paragraphs of Section C7.2, that denial might operate by the use of “jamming” signals that had previously been found capable of disrupting incoming information which, by now, had become unpalatable. But not all unpalatable information will appear as current external communications; much of it will already be securely stored in past memories — having seemed innocuous at the time, or having been too intrusive to be ignored. (Indeed, mere denial or ignoring will arguably never suffice to fully exclude such material from subconscious memory, once attention of some sort has fallen on it). Anyhow, given the existence of such material in memory, then it will tend to persist as a potential disrupter of existing group-like structures which are important to the general self-image structure. So, in the interest of maintaining the comparatively pleasurable closure, it will make homeostatic sense for the brain-system to emit similar “jamming” signals to exclude such *internally stored* information from the system’s own “Consciousness Centre”, and/or from other, perhaps higher,  $M^1L$  levels.

If mental energy must be expended on the denial of unpleasant external evidence whenever it happens to appear in a noxious form, then the logistic problem for blocking resident *internal* disrupters will be much more of a serious problem — presumably an unremitting full-time job, in fact. The problem will be particularly vexing wherever the unpalatable material is of a hereditary (“instinctual” or  $M^{-1}L$ ) nature; and this will usually mean “sexual” in the wider Freudian sense. Indeed it would seem fair to claim that all cases of repression would have such a hereditary component as a major *ingredient*, though this in itself would hardly have any situational <323> significance — so some sort of learned structure must also be involved, and it is this potentially changeable part which the therapist will perhaps regard as unadaptively constructed and possibly worth remoulding.

The inefficiency of such a system might be compared to that of an authoritarian business organization or political regime. On the one hand, there will be a considerable demand for resources to police the activities of the production-force (comparable to the expenditure of mental energy, considered above); and these measures will not necessarily even produce the immediate

effects desired if, as Townsend (1970) has suggested, the pilferers and deceivers “merely get more inventive”! On the other hand, there will be the loss of production from the interference of the policelike activities — especially when they happen to encroach on the “law-abiding” citizens; and in the present context this could be interpreted as blocking quite innocent schemata, either because their significance is misconstrued at the relevant subconscious level, or simply as a side-effect arising from inadequate specificity. Moreover, an unwelcome by-product of such blocking will be the gaps — the failures in internal closure — which will follow from the effective elimination of “group-members”. Such flaws may even rebound on the ego itself, arguably constituting the cause of depression.

Another important analogy which should certainly be mentioned here (though this is not the place to investigate its implications) is the immunological use of *antibodies* to block the development of proteins in the body, when these have been identified as foreign. This analogy is particularly apposite because there is a plausible chance that some of the actual mechanisms could be very similar to those postulated for mental repression. Perhaps the most important difference is that whereas immunology contemplates the more-or-less direct contact between chemical entities, the current mental model is prepared to encompass such influence *at a distance* via the intermediary of patterned infra-red phonon-signals.

As for the role of psychotherapy; it was early recognized by Freud (1900/1953, page 106), that it was not sufficient merely to confront the patient with *the facts* concerning his locked-on mental state, and indeed such diagnosis was a comparatively small part of the task. To confront in this indelicate way, is merely to invite denial of this intellectual ( $M^2L$ ) input — and possibly broader denials involving the therapist himself or even *all* non-vital  $M^2L$  activity as “long-haired academic pie-in-the-sky”! In formal terms then, the art of the therapist might be interpreted as inducing new mental constructs which will eventually convert the existing meta-stable structure into an unstable structure which will then “roll, on its own accord” into the more valid state which will accordingly be more stable in terms of group-like properties. In other words, given a position on a “maximum” which is only optimal in a local sense, the task is to fill in the saddle between this peak and the higher, more general maximum. Without the dividing saddle-contours, the system’s own maximizing procedure will then automatically cause a move from the old meta-stable sub-peak, up *continually* toward the main peak. However this must all be done without arousing undue denial activity, and this will involve the correct balance between accessing the emotions ( $M^0L$ ), the intellect ( $M^2L$ ), and the more intuitive modes of the thought in between.

### C7.5 Other defense mechanisms: — Isolation, Reaction-formation, Undoing, and Regression

#### *Isolation — using higher $M^0L$ mental activity?*

In the case of *isolation*, the painful phenomenon itself is recalled without being repressed, but there is a failure of recall concerning its significance and associations. That this should be regarded as a specialized form of repression, is suggested by the fact that the patient “shows the same resistance to a demonstration of the true connection that a hysteric shows to the reawakening of his repressed memories” (Fenichel, 1946, page 155). The text continues: “Thus here again a counter-cathexis is operative; its operation consists in keeping apart that which actually belongs together [Laforgue (1929)]”. In the context of the present theory, this rather looks as though the repressing signals or counter-cathexes have chanced to disrupt the syndrome of thoughts *at the  $M^1L$  level* rather than at the more usual  $M^0L$  level (or perhaps even at the  $M^2L$  level rather than the  $M^1L$  level!). Anyhow the result would seem to be a disruption of extensive-set operation, rather than a disruption amongst its would-be members. As we shall see, and as mentioned by Fenichel and Laforgue, this is likely to have some relevance to the concept of psychosis.

The previous paragraph has taken “countercathexis” as synonymous with “blocking-signals” which have been postulated to operate in the manner of Figure C6.7/5. There is an alternative mechanistic interpretation however; and this entails considering the countercathexis as if it were a negatively-directed vector (rather than a switch relay), presumably taking the form of a negated mutant of the original scheme — and now in competition with it. One might be forgiven for doubting the stability of such a mutated arrangement without further elaborations. So let us suppose that traumatic conditions gave rise, at some stage, to support for some fortuitous *group-like* schema which both *contained* the negated mutant, and managed to be sufficiently group-like (without the original scheme) for it to survive under its own stability. Needless to say, such a structure would not mix compatibly<326> with structures closely connected with the original scheme; and as the latter is presumably hereditary and infinitely renewable, conflicts seem bound to occur from time to time, quite possibly involving attempts at mutual repression via blocking signals — thus involving two interpretations of the “countercathexis” concept within the same general phenomenon. After all, there is no obvious reason why both types of countercathexis should not co-exist.

327

### *Reaction formation*

Anyhow, it seems plausible to associate the blocking-signal type with “repression” in general, as was done above — and to attribute the countervailing-schema-vector to the subtly different phenomenon of *reaction formation*. Given this postulated distinction, it is of some interest to see what Fenichel has to say on the matter, (page 151):-

“Do reaction formations represent a separate and independent mechanism of defense? They seem rather to be a consequence and reassurance of an established repression.”

It could well be that a blocking-signal system will always come first and perhaps remain throughout any development of vector effects. He continues:-

“But at least they specify a certain type of repression, which can be distinguished from other repressions. It is a type of repression in which the countercathexis is manifest and which therefore succeeds in avoiding oft-repeated acts of secondary repression. The reaction formations avoid secondary repression by making a ‘once for all’ definitive change of personality.”

The above-suggested new schema (containing the negated mutant) might reasonably be identified with this “definitive change of personality”; and in both cases the structure must be regarded as less than ideal — and thus, in some sense, no more than meta-stable.

### *Undoing*

If we play wrong notes whilst practicing a musical instrument, then we may be able to make full amends by re-playing the same passage; and some types of damage can also be fully amended. <327> Often however, no such restitution is physically possible in the “real” world, and then there is the temptation (at least at a subconscious level) to try to alleviate the feelings of guilt or inadequacy by *symbolic* correction to the original action or thought. This constitutes “*undoing*” in the psychoanalytic sense; and leads us on to the important question of just what is entailed in such “magic” or “symbolic ritual”.

328

In the case of re-enactment, it may well be that a very faithful reproduction of the original event will be devised, though with a “happy ending” this time — like the rehearsing musician. But unlike the music rehearsal, the original damage was irretrievable in some way, so there will remain one very significant flaw in this ritual repeat — a flaw which must somehow be swept under the carpet, doubtless by the use of some variety of repression. We may expect that the result will then be some partially satisfying group-like structure, whose dubious stability will require ever recurring repression and/or re-enactment to sustain it.

Whereas the wishful thinking of re-enactment tries to turn the clock back and start again, the alternative approach of restitution will presumably accept the damage of the original *faux pas* but attempt to *reverse* the original process. Where this cannot be fully achieved in the real world with the original people and objects, then some more amenable substitute domain will have to be found. Such symbolic restitution might even make amends in an overall social sense through “good works”, though presumably not fully benefiting the persons originally seen to have been injured; or the restitution could be an entirely ritualistic expiation of sins. In either case there is likely to be an intellectual ( $M^2L$ ) rationale to support the procedure, probably taking the form of a “repayment of a debt” — either to society, or to God, (respectively). <328> Moreover it is arguable that in some cases this ploy will succeed, in that the resulting ensemble of structures including the ego and superego will turn out to be self-stabilizing without the need for blocking signals. This would however, presumably entail a change of aim and so fall under the heading of *sublimation*, which is considered to be non-pathological (see Section C7.1, above). But then, of course, there is no guarantee that such a satisfactory outcome will eventuate — and such failure may fairly be regarded as a form of neurosis.

So far we have considered the efforts at both re-enactment and restitution as taking place in the real world, even if it did tend to be the “wrong part” of the real world — with substitute objects, used symbolically. These transactions will, of course, have a mental counterpart; and we might well expect this mental component to exist on its own sometimes, as straightforward fantasy. Indeed, in the case of worry over trivial mistakes or transgressions, it would not be too much to expect that acceptable solutions might be found in this way — quite likely incorporating mutant material, and possibly constituting trivial equivalents of sublimation. And even if we cannot accept this as a plausible outcome for wakeful fantasizing, it does look remarkably like the “wish-fulfilling” aspects of *dreaming* which we discussed in Section C6.6.

### *Regression*

*Regression* to an earlier mode of behaviour, may perhaps be best explained in terms of the Ashby conceptualization — a switching from one mode of mental organization which does not seem to be producing rewarding results, into another mode which might plausibly work better in view of its usefulness in the past. There is thus an element of purposefulness in such a change, though as the outside situation will probably no longer be suitable for the older type of response, the “purposefulness” will fall somewhat short of that <329> identifying-of-the-suitable-occasion which was discussed in Section C4.5. It will however be an advance on the random change of Ashby’s simple homeostat system which we looked at in Section C4.4, so perhaps we should regard it as an intermediate case.

We should notice an important difference in emphasis however. Whereas Chapter C4 was concerned with the  $M^0L$  level mechanisms operating to select between  $M^{-1}L$  alternatives, later generalized to viewing  $M^{i+1}L$  levels as choosing between  $M^iL$  alternatives, it seems here that we should be choosing *between levels as a whole* rather than between alternatives within any one of them. Such choice between levels could be more-or-less self-regulating, or it could be under the control of some extra-hierarchical system such as “consciousness” or “attention” (see Section C6.4, paragraph 3 ff.), or quite likely *both* influences will be at work. (The self-regulation might plausibly take the form of competitive closure, with mild mutual inhibition tending to suppress the currently less-successful group-like structure). Nevertheless, we should not overlook the possibility that some aspects of “regression” might actually be “*epi-gression*” in structural terms — a return to some other schema within the same  $M^nL$ , and therefore more closely identifiable with Ashby’s paradigm, even if the appropriateness of such behaviour has now been lost for ever.

Anyhow there is something different about regression which sets it apart from other defense mechanisms. Indeed Fenichel (1946, page 160) raises the question as to whether it is a defense mechanism at all, but argues:-

“The typical compulsion neurotic, experiencing a conflict between his phallic Oedipus wishes and his castration fear, substitutes [earlier] anal-sadistic wishes for his Oedipus demands. Thus actually, regression is a means of defense [Freud (1936)]. What must be admitted, however, is that the part played by the ego in<330> regression is different from the part it plays in all other defense mechanisms. Other defense mechanisms are set in motion by an activity of the ego ... ; in regression the ego is much more passive. ... in general, regression seems to be set in motion by the instincts which, blocked from direct satisfaction, seek a substitute.”

331

(And he goes on to suggest that this is made possible by “a peculiar weakness of the ego organization” — which we may interpret as poor closure, including poor agreement with external manifest reality).

### C7.6 Toward a structural definition of neurosis — and of psychosis

The usual approach to defining a phenomenon like neurosis is to seek an “operational definition” to which feasible measurements can be applied without undue difficulty, and this usually means concentrating on behavioural aspects of the phenomenon. By contrast, the philosophy of this present work has been that manifest behaviour is just the tip of the iceberg which tells us distressingly little about what is really going on; so its use for definitions of this sort will tend to be notably uninformative about structure, and only of limited applicability even for clinical purposes. If we then opt for structural definitions invoking unobservable structures, this will clearly also have serious disadvantages as far as direct practical applications are concerned, because we are left with no tangible way of measuring the state of the structure. Probably this is ultimately one of those dilemmas which we have to accept and live with, but there are ways of making the best of the situation; and one such compromise seems to be to first develop a plausible structural set of explanations together with their (structural) definitions — regardless of measurability considerations, and then look again at the behaviour to see whether we now have new insight which might enable us to make better use of the observational techniques at our disposal. Anyhow, it is in that spirit that the<331> current search for structural definitions will take place.

332

So, in the light of our present theory, what structural feature seems to characterize neurotic states in general? Posed broadly like this, the immediate answer will be equally broad and comparatively mundane; something like the following perhaps:-

*“Neurosis is a state in which, as a consequence of coping with some unpleasant experience, a structural arrangement has arisen which (given the prevailing environment) precludes the evolution of better adaptive adjustment(s) otherwise available, and also remains stable despite any lay attempts to re-mould or dissolve it.”*

But even if we improved on the wording of this definition, there would remain some legitimate doubt as to whether it really amounts to a useful structural definition. Maybe it is impossible to dispense with all behavioural connotations like “adaptive”, but whether this is true or not, we can perhaps amplify the statement by looking separately at *different types* of postulated neurosis-causing structure.

On the basis of the previously mentioned mechanisms, there seems to be reasonable justification for identifying two main sources of neurotic blockage; though we shall then see that there is likely to be a supportive interplay between them. Firstly there is the more-or-less permanent commitment to the use of *blocking signals* to keep disturbing ideas, inputs, or instinct, from upsetting the precarious equilibrium of the existing self-concept (ego), or some important



aspect of it. This postulated mechanism and the logistical problems it is likely to entail have already been discussed in Sections C7.2 and C7.4, so there is no immediate need to elaborate further here. Suffice it to say that it seems to be the predominant factor in *denial*, *repression*, and *isolation*.

The other main cause of neurotic deadlock takes the form of <332> “over-successful” mental structures — *fixations* onto concept-ensembles which have worked well under past conditions and thereby built up a cohesion and stability which is more-or-less impervious to changes in the individual’s physical or social environment. (Social analogies to this fixation are to be found in abundance — not least amongst spectacular advances in scientific theory which turn out eventually to have been only partly right). Anyhow fixation is recognized as being intimately involved in *regression* (Fenichel, 1946, page 65 — after Freud, 1920), so we may take it to be the predominant factor in this case, and also for cases of *projection* and *introjection* — using primitive “good = me, bad = other” criteria.

333

### “Countervailing forces” — How plausible are they in Reaction Formation?

One might also argue in favour of a third basic factor contributing to neurosis:- the opposition of countervailing vectorlike “forces”, as considered in connection with *reaction-formation* in the previous section. This is a moot point, but here we will tentatively suppose that this phenomenon is actually a composite of both these factors together with the otherwise-benign sublimation/mutation phenomenon; hence it would be more structurally informative (and parsimonious) not to accord it separate status as a fundamental basis. It is not too difficult to imagine that a fairly simple and common mutation could insert a “not” into hereditary scheme-elements, so that these straight contradictions would then be available for competitive evaluation in Darwinian terms; and this supposition finds support in Freudian theory:

“the anti-instinct forces have an instinctual character because they are derivatives of instincts [Freud (1927)]. The instinctual attitudes of the children toward their parents are turned into forces hostile to the [same?] instincts by [*supported* by?] an introjection of the parents.”  
(Fenichel, 1946, page 103). <333>

Whether such reactions are to turn out as adaptive sublimations, or as non-adaptive encumbrances would seem to depend partly on the chance eventualities of the mutation process, and partly on the scenario of events taking place in the environment and reflected internally by introjection and other reality-oriented constructs. If these negated mutants are totally non-adaptive, then they will presumably find no closure and therefore suffer dissolution; but otherwise they might well find closure support with introjected superego constructs, thus contributing to adaptivity in a partial sense, and quite likely surviving.

334

In sublimation (where the mutation is presumed to change the aim, but not actually negate the original hereditary instinct) it seems that the mutant can control the instinct without resorting to neurotogenic signal-blocking (Section C7.1, paragraph 3<sub>not 2 now</sub>); here however, with straight negation, it would appear likely that such repressive attempts to “jam” out the hereditary impulses will be encouraged whenever they evolve spontaneously.

The other, more mathematically satisfying, concept of opposed vectors sounds sensible initially — but it presents difficulties when we come to think of ways it might actually operate. How could signals, *as such*, negate each other? Unless they can switch each other off (as proposed above), or destructively interfere optically at all relevant points (!), it seems that the two conflicting signals would have to wait until after they had been received by their respective antagonistic muscle-fibres, or whatever; though it is conceivable that some forms of neurotic muscle tension could be just that! Anyhow, whichever account we accept, there seems some justification for regarding reaction-formation as a composite phenomenon rather than a simple basis in its own right.

The possibility of such composite phenomena raises the question of whether repression is likely to entail *pure* signal blocking, or<334> whether fixation entails *pure* over-stability. On the simple logical basis that one can hardly have a stable system in which all the relationships are negative, we might reasonably suppose that behind any repression phenomenon there will be an over-stable “vicious circle” group-structure — or maybe more than one. At first sight we might expect an overstable system to be • entirely self-contained with no need to try to block other signals; but then, in so far as it is non-adaptive, • conflict with other attempts at closure are bound to arise — so we may expect blocking-signals to evolve within the system somewhere, even if they do not emanate from the overstable part itself. Thus we should be prepared to consider any real “neurotic” system as comprising a finite quota of both of these components (amongst other factors like mutation), though without doubt the “proportions” and “arrangements” of these will vary amongst the various Freudian paradigms as suggested above.

335

### *Psychosis, and how it probably differs structurally from neurosis*

By contrast we may suppose that *psychosis* does not necessarily entail any such definitive self-perpetuating structure, though such structures may well have been the immediate cause of the psychotic condition — perhaps even serving to maintain it. Whereas neurosis was seen as consisting structurally of a particular type of organization for the internal information processing, psychosis may rather be seen as one or more specific *deficiencies* in such organization. Putting it rather more formally, we might say:-

*“Psychosis is a state in which there has been a dissolution of one or more of those extensive-set organizing structures (in its effective collective form) on which the overall mental organization has come to depend, thus resulting in a measure of disorientation.”*

This calls for several comments. Firstly, it should be distinguished from those cases in which (say) the  $M^2L$  level has not yet developed at all, so that the overall organization cannot be<335> said to have become dependent on it. Secondly, the statement does not preclude the possible permanent or intermittent recovery of the damaged organizing agents; for instance, their subliminal remnants might well re-proliferate under suitable circumstances. Next we might hazard a guess that one way in which the dissolution could have arisen is through coming to accept essentially incompatible members into extensive-set “lists”; so that, like a social club with too mixed a membership, spontaneous disintegration is likely to follow. Fourthly, we may expect to find different types of clinical psychosis depending on which  $M^0L$  level or levels are effected, or indeed which of the (probably existing) subdivisions within such levels are the ones involved.

336

Finally, where such  $M^0L$  organization is anything like persistent in its clinical manifestations, then this will not auger well for a cure by psychotherapeutic means because the therapist usually depends most on contact via the  $M^2L$  level (for at least some of the important aspects of the therapy), and this level will be most vulnerable to disruptions of the type depicted — even if it is primarily some other level which has been “dissolved”, because the  $M^2L$  level will be somewhat purposeless or undeveloped without the continuing full complement of lower levels (on which to test and prove its closure ability). Moreover a similar argument would hold for the main alternative route, the  $M^1L$  level, though here the case would be a little weaker since any  $M^2L$  failure could now presumably be eliminated from the set of contributory causes. We shall look at specific clinical symptoms in Chapter C8, below.

### C7.7 Paranoia as a neurosis which may be one cause of psychosis, and therefore often exhibiting aspects of both

English and English (1958) offer the following dictionary definitions:-<336>

“*paranoia*: ... a (rare) psychosis characterized by systematized delusions with little or no dementia.” -

337

to which they add the comment that this system “though extensive, is relatively isolated and thus leaves the rest of the personality largely unaffected”. They then contrast this to:-

“*schizophrenia/paranoid*: a psychosis characterized chiefly by autistic and unrealistic thinking, hallucinations, and many often highly elaborate and systematized delusions, particularly of persecution and grandeur. The whole personality is affected and there is apt to be deterioration; hence the delusions tend to be, and especially to become with the passage of time, less systematized. ...“

To Fenichel (1946, page 147), the salient feature of paranoia is its abundant use of *projection* so that the outside world is used, sometimes unfairly, as a scapegoat for the paranoid person’s own shortcomings. Or to put it another way, he “prefers to feel dangers as threats from without” because this appears to give him more control via those “mechanisms of protection” which are actually “against external stimuli only”; (*ibid.*, after Freud, 1922). In fact: “The paranoid is sensitized ... to perceive the unconscious of others” such that this assists him to rationalize his own projection tendencies, presumably giving them the respectability of a pseudo-closure at the  $M^2L$  level as supposedly rational thought; and this “enables him to become oblivious of his own unconscious”. He will, perhaps, assume a god-like transcendent role in which he sees *himself* as exempt from requiring anything so mortal, mechanical, and dubiously-controllable as an unconscious.

Of these two accounts, the first emphasizes the psychotic features, while the second stresses the neurotic elements. Could they both be right? The view promoted here is that paranoia is *structurally* a neurosis, at least initially, but that it happens to be a type of neurosis which places the patient in a *perceived*<337> *world* which has psychogenetic properties. Thus the structural neurosis is likely to first come to the attention of others via the secondary psychotic behaviour arising from it; and the process could well, in some cases, continue on further and further into psychosis — both structurally and behaviourally — as outlined in the square-bracketed paragraph toward the end of Section C6.3, on the basis of Laing (1960/1965, 1961/1971).

338

By way of detail, it would seem that the neurosis would consist of a fixation onto that primitive schema (myself = good, other = bad) which we discussed in Section C7.3 as a contributing factor toward the formation of the ego or self-concept. In “normal” circumstances, childhood experiences “should” ensure that the *other = bad* concept will dissolve away through lack of external closure — given sufficient supporting experience with a friendly external world; but a hostile environment will rather serve to preserve this “basic mistrust” (Erikson, 1950). (Moreover such preservation may well be adaptive, and it is worth considering when looking at the difference between sub-cultures, or between tame and wild animals). Meanwhile the egocentric *myself = good* aspect will fail to become *decentred* (in Piaget’s sense), thus leaving the individual with an exaggerated feeling of god-like infallibility. Once such a person has reached the stage of attaining an internal closure of his  $M^1L$  structures to account for these phenomena (elaborated later into  $M^2L$  delusional rationalizations), it will be very difficult to shift them from this state — even if their suspicions are unfounded, but even more so if there is some substance to them. Nor is it difficult to see reasons for this impasse: their own conceptualization will supply them with supporting *positive feedback* whether this is valid or not, and they are not likely to accord trust to any would-be helper — even if the helper has no conscious or<338> unconscious ulterior motives which an astute patient might detect.

339

In an adequately congenial environment, such a person would probably not progress beyond mere neurosis — though of course he might, himself, cause the environment to become uncongenial! We may consider the particular danger that he will find himself placed in a situation in which he cannot avoid “contamination of his special position” due to the intrusion of the will of others onto himself. It is to resolve this dissonant situation that he takes the psychogenetic step of trying to adopt a more restricted definition of his “*inner self*” *set*, which seems to offer a new independence from the “obnoxious” environment — at the price of abandoning some of his own mental territory to it, and withdrawing further into the fortifications of his own mental “castle”; (Laing, 1960, 1961 — as above). This then, is the other extreme depicted by English and English’s definition of “paranoid schizophrenia” (above); and presumably there is some scope for equilibria in between these two extremes, in particular circumstances.<339>

R R Traill (HPS) — ThChapt7.d 12/10/95 1215

## Chapter C8

**DEVELOPING A CONSISTENT AND REASONABLY COMPREHENSIVE  
STRUCTURAL THEORY OF PSYCHOSIS**

340

## SUMMARY OF CHAPTER

This chapter goes still further into details of how the brain is likely to have to organize its coded elements into various types of ‘intensive’ and ‘extensive’ sets. It is argued that the best results will be obtained when several such methods are available simultaneously — used in parallel in a pluralistically oriented environment, and that this would be likely to cause considerable difficulties for experimental investigations of the microstructure (where statistical methods are envisaged). These concepts are evaluated in the light of existing clinical and experimental evidence relating to schizophrenia, considering the likely effects of diminished pluralism in producing this sort of impaired mental performance.

**C8.1 A closer look at the likely mechanisms whereby implicit “intensive” sets might become organized into the two-or-more types of extensive set***“Intensive” for description, “Extensive” for boxes and leashes — a reminder*

To organize thought about the world, one must have workable ways of arranging items into “mathematical” sets. There are several different approaches to this task and, at the risk of repetition, it may help to remind ourselves of the main possibilities, and the “Intensive/Extensive” terminology used by Piaget. One obvious way is to specify some property which all members must have: *Red* objects, or Items which have been *ticked* or fitted with a certain *electronic label*. These are **intensive** definitions, and they have the advantage of flexibility and universality; but they may be difficult to apply in practical activity, especially if we need to act rapidly. For better control, we may need items to be captive in some sense — in a box, or a file, or fenced enclosure, or each tethered to a central bouy by ropes, or in a loop of neighbours each linked bilaterally by some physical-or-virtual attraction, etc. These are **extensive** definitions, with the items being set-members by virtue of their location within an extended region (however that may be defined).

If there happen to be further viable strategies, so much the better; and hybrid techniques should also be useful. The main point is that facility with a variety of these set-manipulating methods offers mental versatility — and we probably spend much of our time translating one type into another in our daily life-tasks. [RRT, 2006]

*Practical set-defining Systems?*

In the latter half of Section C5.2 we looked at some of the problems of how the brain might develop physical representations of mathematical sets of entities, but without coming to any clearcut opinions as to detailed mechanism. It seems likely though, that any thoroughgoing explanation of psychosis will be closely bound up with details of this type, so it will be prudent to come to rather more definite ideas on such matters of set-organization before proceeding.

Rather than building directly on the proposals put forward previously, let us look at an apparently new alternative suggestion for the basic mechanism — with a view to doing a comparison later on. Looking back then at the pure **base sensorimotor** level **m<sup>0</sup>1**: Is there any likely scope for set-like organization using only the intensive definition for set-membership? In order to explore some of the implications of <340> such intensive definition, let us suppose provisionally that the ordinary basic linear-elements of this level (as depicted in Figures C5.2/1

341

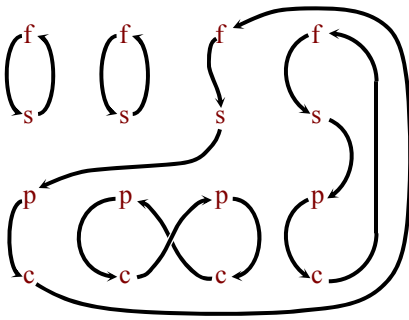

Fig C8.1/1. A possible association-pattern amongst an ensemble of elements, in which each element is required to have one affiliation to another element, (a simplifying assumption). <342:topL>

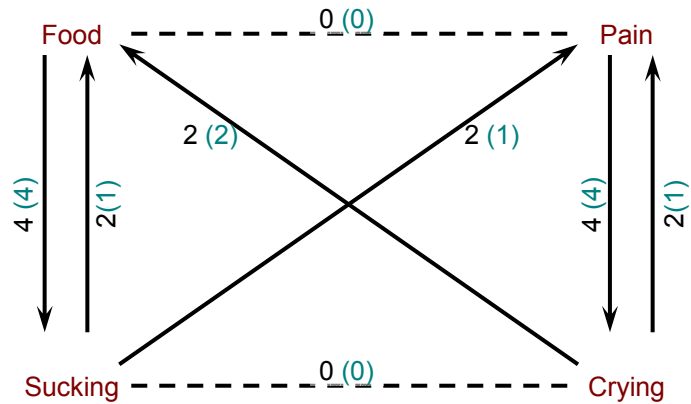

Fig C8.1/3. Strengths of concept associations as depicted in Fig C8.1/1, (and Fig C8.1/2); see text. <342:bottom>

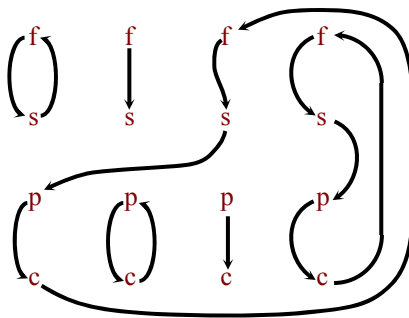

Fig.C8.1/2. Another possible association-pattern amongst an ensemble of the same basic elements, but one in which each element is permitted to have either one affiliation to another element — or none; (a different simplifying assumption). <342:topR>

and C5.2/2)<sup>73</sup> have an additional ability to keep one<sup>74</sup> name-association reference each — a reference by “name” to some other scheme-element of the same level, without normally activating it. (We may refer to such nodes in the linear string as “ $\beta_i$ ” — anticipating their formal equivalence to similar symbolic calls postulated for  $m^{1/2}$  elements). But as each scheme is considered to be made up physically of a whole population of linear scheme-elements, and as each element (specified by “i”) would presumably be free to form its one association (“ $\beta_i$ ”) according to its own idiosyncratic history-of-experience, it therefore seems that the scheme, as a whole, will have an effective “network” of associations to other schemes — roughly in proportion to the associations actually experienced as significant in the past.

As an illustration of the system proposed here, consider a population of people each of which can like only one other person in the population. If each person does actually like one person, then a diagrammatic representation of the situation would look like Figure C8.1/1, with a complete complement of closed loops; but more plausibly there would be some who would not like anyone at all, and these would result in a number of “unclosed loops” or linear topologies as in Figure C8.1/2.

Suppose further that the people can be categorized strictly and unambiguously into an exhaustive list of mutually-exclusive sets such as *age-group* or *surname*. In this case we may suppose that each different letter in the adjoining diagrams denotes a different surname, and in calling the surname “f” (say) we will inevitably call forth<341> a reference to “s”; but a call to

<sup>73</sup> Figs.C5.2/1 and C5.2/2 are on “original pages 192-193”. Likewise for Fig.C5.2/3, see o.p.199-200 — and for Fig.C5.2/4, see o.p.201-203.

<sup>74</sup> This is a simplifying assumption. In practice the number could well be more, or simply variable. <341>

“c” might lead to “f” or to “p” — or to nothing at all perhaps, in one random alternative of Figure C8.1/2. If we now leave our analogy of the population of people and return to our postulated population of mental scheme-elements, then we may use the different letters to denote four different schemes (each with a token population of four elements); e.g. f=food-sensation, s=sucking, p=pain, and c=crying. Thus the situation depicted will be roughly as shown in Figure C8.1/3, in which the strengths of the association linkages will be as given by the numbers beside the arrows: plain for the Figure C8.1/1 situation, and in parentheses for the Figure C8.1/2 case. <342>

### *Some biological considerations, and multi-choice possibilities*

343

Unfortunately this still leaves quite a number of questions unresolved, even assuming that the new basic assumption of only-one-reference-per-element is correct. What exactly is the nature of such references likely to be? Are they to be thought of as a sort of (normally inactivated) “radio call” to the other elements, or should we think of the other elements as having become *physically attached*? Or should we allow for both, with the first perhaps leading to the second? (Moen, 1973; also Chapters B1 and B2 above). Associated with this problem is the question of whether any “call” of this sort will be addressed to some *particular* individual element (such as the “p” on the left of the diagrams) or simply to all “p”s within reach which are not already captives of some prior or stronger influence.

When faced with this sort of dilemma in a biological context, it seems to me to be best to assume provisionally that all such mechanisms occur to some extent — within a pluralistic environment, and having some sort of statistical mix between the alternative possibilities. We may later find that some or most of these supposed alternatives are untenable after all, but then all we need to do, in a formal sense, is to allocate a statistical-probability coefficient of zero for such cases. In taking such a view, we may find some considerable encouragement in the example of *chemical resonance* in which one considers a number of likely chemical structures based on formal traditional notions of bonding, and then considers that the “actual” structure is a kind of hybrid or random-alternation between these traditional <343> structures. Moreover we should not forget that we are dealing with mental elements which are presumed to function at the molecular level, so we should not be too surprised if we find ourselves invoking principles which are in commonplace usage in chemistry.

344

However the immediate task in this section is to try to be definite and specific, even at the risk of being somewhat inaccurate on points of subsidiary detail. Perhaps the best compromise is to lay down what seem likely to be the predominant trends of structural development, then try to apply them collectively to clinical and experimental observations, and meanwhile make amendments of emphasis wherever these seem to be necessary. (After all, this is probably the strategy which the brain itself adopts, especially at the sensori-motor level). Moreover it might well be that *different* alternative methods will predominate at different stages or for performing different types of task.

If the non-tactile “radio-call” association contact between elements were to be the predominant method of linkage, this would probably be highly flexible but also it would presumably be rather cumbersome and unreliable. As such, it would seem to be a good candidate for the initial primitive-and-impressionable organization for the new-born individual; and it is not too difficult to envisage other arrangements evolving out of it. In such circumstances, an excitation of an “s” element will elicit a call for some other type of element — let us say that it specifies a “p” — and this will operate in <344> a crude way to signify that “p” is also to be considered as being a fellow-member of the same set (and not, in this case, as something to be put into effect — a distinction which we will come back to shortly). For this purpose, we may reasonably assume that the call is addressed indiscriminately to *any* “p” which happens to be

345

within range, rather than to any particular one, thus introducing a random component into the operation whenever there is any actual difference between elements which pass as “p”s.

For a more reliable arrangement we might consider the alternative of an actual tactile linkup between such elements. (Note that as long as we are only admitting the possibility of one-or-none symbolic references from any one element, then such a physical linkage system does seem feasible — without the likelihood of unmanageable branched tangles which might be expected from other super-linear linkage systems. Of course this tangle-problem would disappear in proportion to the *looseness* of the physical linkages — presumably vanishing altogether when the linkages no longer deserve the description “tactile” but have reverted to the “radio-call” linkages which we have just considered). In fact though, in the final analysis, the distinction between “tactile” and “radio-call” linkages is probably less clearcut than we tend to assume in our everyday lives:- Infra-red “radio-call” signals would certainly be of an electromagnetic nature, but then it might be plausible maintained that the relevant types of chemical bonding involved in a “tactile” link would<345> also be electromagnetic in character — though probably with a different type of phase relationship between the electric and magnetic components, as in the distinction between near-field and far-field properties of radio antennae (Walter, 1970; Skilling, 1962).

346

### *Molecule-like list-codes*

However, be that as it may, we are now considering the closely connected “tactile” type of linkup: so our task now should be to contemplate the likely consequences of such an arrangement, and the mechanisms whereby it might feasibly develop. If the system is to be manageable, it seems likely that the individual elements which are to make up such a chain should retain their individual properties largely unchanged, and if the chain is subject to physical stress we might expect that breakages should occur *between* these elements rather than within them. In these circumstances, a feasible geometrical configuration would be a comb-shaped structure with the individual elements comprising non-rigid “teeth” of the “comb” — on the lines of the arrangement as drawn in C5.2/3 though now, of course, with a physical connection of some sort to replace the more tenuous linkage implied by the dotted lines in that earlier diagram. To make this idea clearer, we may now conveniently look at a modified diagram [Fig C8.1/4] — re-drawn to show the new features which we are now considering. It will be seen that the shape is, in fact, more that of a double-toothed dog-comb than one of the conventional type; and the broken lines are now drawn between the constituent elements to emphasize the postulated looser connection between them:-<346> <347:Fig8.1/4>

348

The main thing to notice about this new diagram is that it lacks any “ $\alpha$ ” label to act as a clear-cut reference-point to the set-as-a-whole, so that its only means of reference must presumably be via the labels of its individual members ( $a_i$ ) but especially that of the head-member for that particular geometrical arrangement —  $a_1$  in this case. Such an extra role for “ $a_1$ ” would evidently lend itself to ambiguity, but then a little thought will suggest that ambiguities of this type may be uncomfortably common during the early stages of the development of a generic concept. It is not unreasonable to suppose, for instance, that our early concept of “dogs in general” consists of a list of particular dogs, of which *one particular dog* serves as the paradigm and label for the whole diffuse concept. (This might next be augmented by similar parallel lists for which a *different* paradigm serves as the lead-in; the two separate lists later coalescing statistically due to frequent parallel usage). As another example, we might note that Piaget himself violates logic in this way and uses the term “Concrete Operations” ambiguously — sometimes *including* and sometimes *excluding* the “Pre-operational” sub-period; (Furth, 1969). (Here the inclusive case seemingly amounts to a list-like organization, whereas the exclusive case can be considered as if it were an isolated “member”, independent of any list-structure).<348>

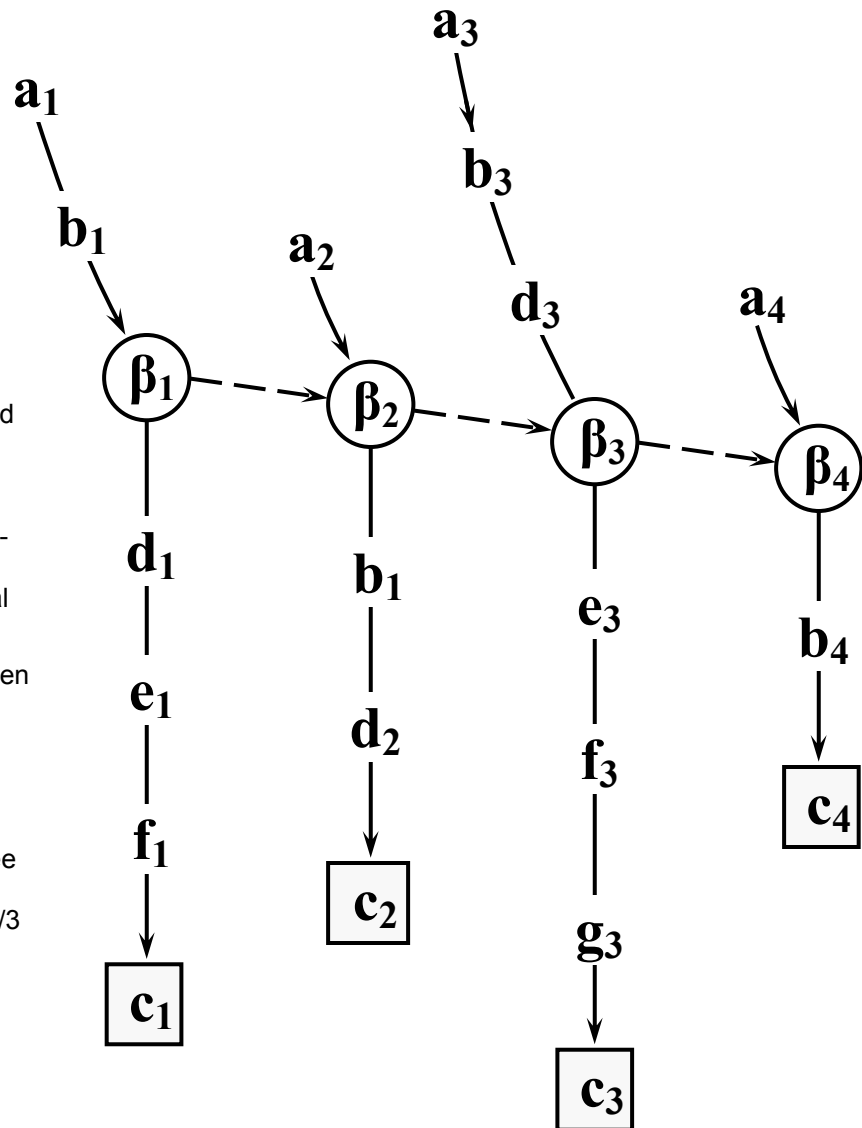

Fig C8.1/4.

Another conceivable arrangement of linear elements formed up to represent a set or "list" of elements.

This may be seen as an alternative to the structures depicted in Figures C5.2/3 and C5.2/4 — though this present structure is less organized (more syncretic), and as such might represent a more primitive method which might, or might not, be a developmental precursor to the other types.

(The broken lines are here seen as a comparatively loose physical bonding, though we have also been considering cases in which such linkages are simply communication channels using "radio-like" free signals such as would be shown dotted in Figures C5.2/3 and C5.2/4). <347>



(347)

There are other differences too, of course. Closely associated with the absence of an "α" label is the fact that this ensemble has neither a specialized *master element* (as in Fig C5.2/3)<sup>73</sup> — nor a specialized *name-code* (as in Fig C5.2/4) to represent the set, as such. Clearly there is also, by design, a difference in the locations of the weaker linkages. In addition, in the version which happens to have been shown here, there is less of an "intensive" uniformity among the member elements as compared with the elements as detailed in Figs C5.2/3 and C5.2/4; so one is more inclined to wonder about the mechanism which would have brought such elements together into the same extensive set in the first place — and kept them there. This is the all-important question on which it is now vital to get as much clarification as we can muster.

349

### *What could hold the mental list-elements together?*

In Section C5.2 it was suggested that there might be a credential-monitoring segment,  $\gamma$ , in the unifying master element Fig C5.2/3 or elements Fig C5.2/4; but there was no detailed suggestion as to how this might operate, and anyhow it is even less convincing here where we are considering a confederation which lacks any master element as such.

Elsewhere in this work it has proved conceptually useful, when faced with apparently-teleological phenomena, to invert the naive concept of causal direction — thus assuming an arbitrary undirected “mutation” which will, on average, be unhelpful to the organism, but will in the long run produce an enduring new adaptive structure by a Darwinian process of selection. Similarly here we may<349> suppose that if an ensemble of the Fig C8.1/4 variety does not prove to have a reasonable norm of (competitive) usefulness, then it will be quietly pushed back into the melting pot. So far so good, but we still need to offer an explanation of the mechanisms involved.

350

There is no great problem in visualizing how the  $\beta_i$  nodes might invade existing elements in an arbitrary manner, thus producing the necessary mutations. The difficulty, as before, is in showing how efficacy could be monitored. In fact though, there would seem to be a solution to this difficulty on the basis of the synchronizing cross-feed principle of Fig C5.2/2<sup>73</sup>, used in conjunction with a trial-and-error procedure:-

In the earlier account of this Monod-and-Jacob system (in Section C5.2), we were thinking in terms of ready-made genetic elements — and moreover these were massed replicates of the same basic structure, arising from a common chromosomal source. But consider the possibility that such cross-feed support systems might arise occasionally between arbitrarily mutating elements which just happened to be within effective communicating distance of each other. As it will presumably be an important property of any meaningful set that its members will tend to be of *simultaneous* relevance, such a synchronizing mechanism would appear to be well suited as a *first step* mechanism for defining the set-membership extensively; but it now remains for us to explain how such membership will relate to the intrinsic intensive properties of the individual elements.<350>

#### *Evolution sequence: Association → Salient member → Label-for-whole*

Darwinian survival of the fittest does not apply only to individuals, but also to *ensembles* of individuals; similarly an individual element representing a particular mutant coding will be more likely to survive (other things being equal) if it has happened to achieve an affiliation to a useful ensemble of elements. So as long as there is a plentiful supply of mutants from which to choose and replicate (and after all, the total population of elements could be vast), then there is a reasonable basis for Darwinian selection amongst the postulated ensembles — simply on the basis of the resulting survival probabilities for their members. Such a process could feasibly account for loose types of concept-association and synchronization of the Monod-Jacob crossfeed variety Fig C5.2/2,<sup>73</sup> or indeed for the sequence of single “calls” depicted in Fig C8.1/4 if this is a viable proposition — or any tenable combination of such cross-references between simple member elements. However it is difficult to see how this, on its own, could explain the more organized type of set representation of Figs C5.2/3 and C5.2/4<sup>73</sup> in which the set has come to be both well defined, and also callable and/or nameable in its own corporate right — like a legally formed public company, largely independent of the status of its constituent members.

351

#### *Probability and Stepwise Evolution*

In Section C5.2 and elsewhere, I suggested that some specialized and newly mutated “master elements” might have the power to set themselves up as arbitrary lists of other elements *and also* then erase their own references<351> to those listed members which did not conform to that list’s arbitrarily preset criterion for membership — thus eliminating from extensively-defined membership all those elements which did not have the “right” intensive definition. Unfortunately however, satisfying these various different conditions simultaneously by trial-and-error must be regarded as tending towards the highly improbable, even given that there are likely to be a very great number of elements capable of mutating in potentially useful ways and assuming also that a single successful ensemble could be rapidly replicated by “reinforcement”. Although ultimately,

352

Fig C8.1/5.  
One simple representation of a syncretic extensively-defined set. In this case the association-linkages happen to centre on the "a<sub>3</sub>" string, giving it a privileged access to the other members. It is thus well situated to capitalize on any chance mutations which would tend to produce versions of it which happen to have properties conducive to its being a "master element" in its new form. <354> (The cross-feed significance of "f" and "p" nodes is the same as in Figure C5.2/2).

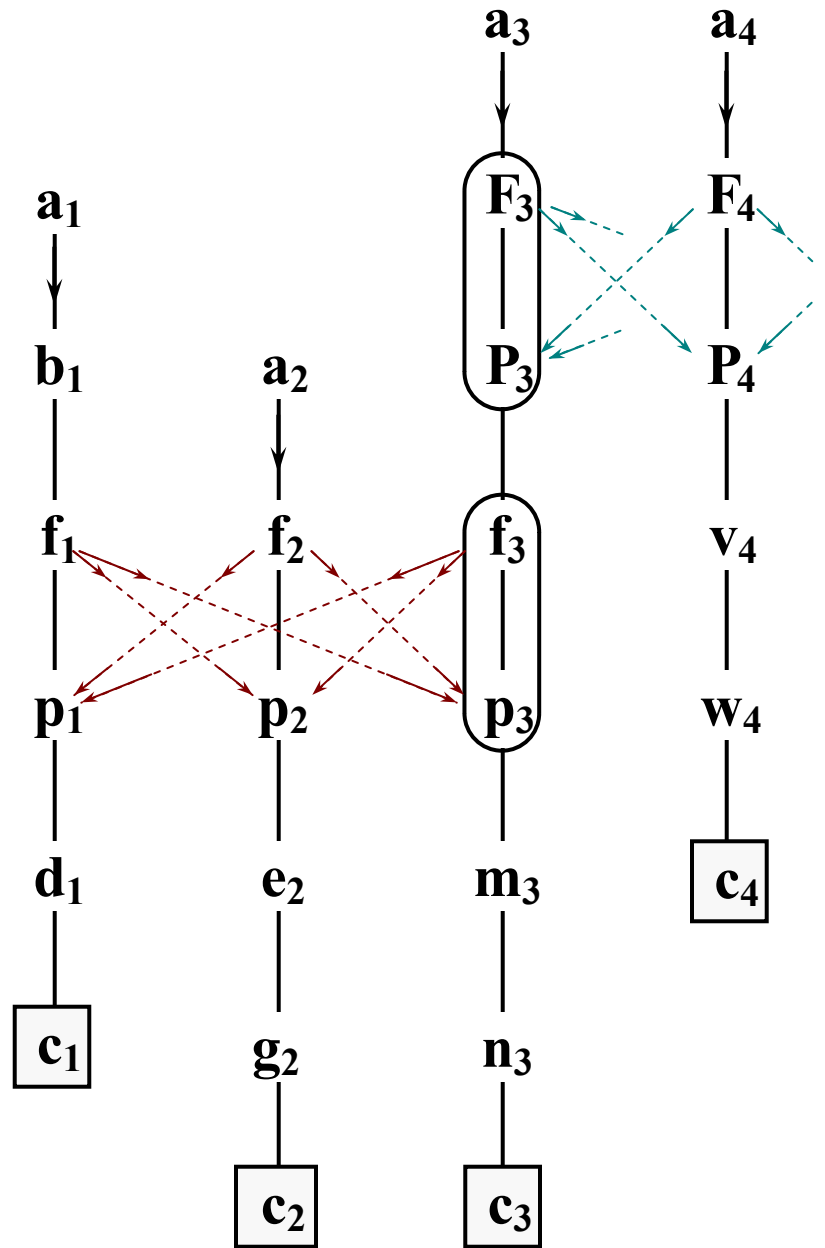

as in genetic evolution, we must apparently accept a progression by trial-and-error as the only possible alternative to a teleological or divinely-guided biology, there are nevertheless limits to what we can reasonably expect trial-and-error to accomplish *in a single step*. Thus we might reasonably credit the occasional spontaneous generation of a virus, but not that of a fully functional amoeba; and it is similarly rather too much to expect the right fully-organized sort of framework for a useful extensive set to appear spontaneously, except perhaps on rare occasions.

But we have just seen that there is at least one plausible trial-and-error process for a part of the job of developing an extensive-definition of sets, so it is now open to us to see whether there might be *other* mutational steps which could result in the same <352> sort of sophisticated system as those considered in Section C5.2 though in a more credible stage-by-stage manner. Let us therefore suppose that our cross-referenced syncretic type of thought-association cluster has evolved within the brain, as postulated in the above paragraphs, and try to explain how this could

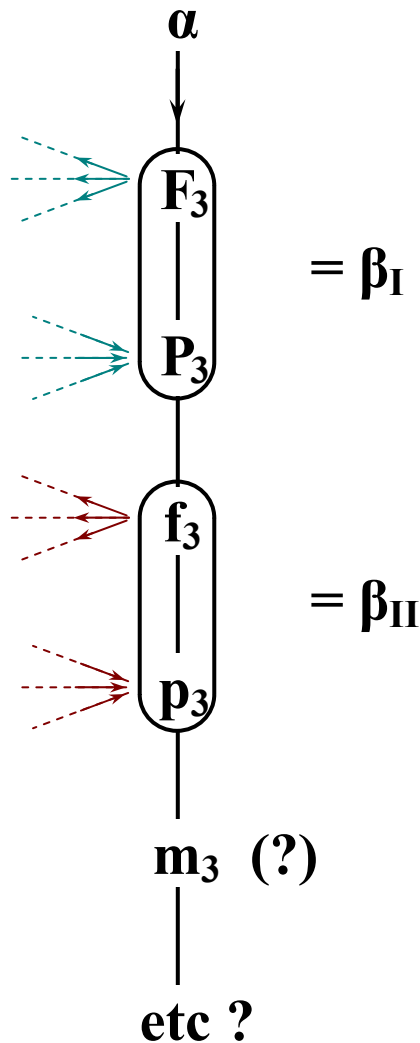

Fig C8.1/6.

&lt;355&gt;

This depicts the sort of change which might occur to the “a<sub>3</sub>” string of Figure C8.1/5, resulting in a “master string” similar in function to that depicted in Figure C5.2/3, but arising from rather different circumstances. The main change would probably be some alteration to the label part such that the a<sub>3</sub> label-coding would become differentiated from other a<sub>3</sub> exemplars, resulting in a new label “α” which could now serve as a reference for the set as a whole rather than for its “most prominent” member. In its new role, other codings on the element, such as m<sub>3</sub>, would probably not be maintained by usage and would therefore tend to disappear from the new master-elements — though not from those “a<sub>3</sub>” elements which still retained their old function as representatives of the particular member of the set.

(355)

evolve further into the well-controlled extensive sets envisaged in connection with Figures C5.2/3 and C5.2/4.

It can be seen from Figures C8.1/5 and C8.1/6 that one type of evolutionary change, potentially capable of working successfully, would entail a mutation to the label of one exemplar<sup>75</sup> of one salient member of the set. In favourable circumstances, the new form of the label would fortuitously tally with separately evolved “call” codings on other elements which would then be likely to take on a role of set-manipulation from within the next higher level of the M<sup>n</sup>L hierarchy — in a way similar to that envisaged for the fortuitous growth of control over reflex schemoids during the sensori-motor stage. <353>

356

Thus we now have a rather more credible postulate on how a well-controlled set might evolve — in *two* steps instead of the single step proposed in Section C5.2, and which for the moment we may simply refer to as “step 1” and “step 2”. In view of the supposed potential for occasional further development of group-like properties, we should also bear in mind the likelihood of there being potential for another — “step 3” — as well; but as this seems likely to have only secondary relevance to our present concern with causes of psychosis, we need not develop this further idea in any great depth here. Suffice it to say that it might well involve a selection in favour of mutations which enhance the symmetry and orderliness of syncretic ensembles like the (over-simplified) one depicted in C8.1/4; but it is reasonable to suppose that “step 2” could be a prerequisite for this type of development, or at least be of some considerable assistance.

<sup>75</sup> Here we should bear in mind that, according to the current theory, there would normally be many such exemplars existing redundantly in parallel; so any single one of them could readily be released for other purposes. <353>

### *Rival “ $\alpha$ -masters” as a possible factor in psychosis*

However, returning to the discussion of step 2 itself, it rather looks as though such an evolutionary process might occasionally run into trouble when there are rival claimants among the set’s membership for the role of “the most salient”, or at any rate when these or other circumstances lead to there being rival “master-string”  $\alpha$ -structures whose properties are in some way incompatible. Such rivalry for the “empty throne” may well be quite common in the early stages of step 2, and perhaps even the later stages as well, without necessarily causing any great disruption. Moreover as long as rival formulations can be kept<356> communicationally separate by compartmentalization, then there may be no harm in such an arrangement even in the long term. However if some important conceptual structure of a higher  $M^N L$  level has been built on the basis of one set of  $\alpha$ -schemata, and if these become eclipsed by, or confounded with, a new set of  $\alpha$ -schemata before the system has had sufficient time to adjust, then this higher  $M^N L$  system is likely to be thrown into major confusion whenever the second type of  $\alpha$ -schemata is in the ascendancy. To what extent this could be avoided by gradual transition, or by psychotherapy or whatever, would presumably depend very much on the particular system and the prevailing circumstances.

357

Anyhow we shall here take it as a postulate that confusions of this type are a decisive factor in the production of clinical psychosis, and it seems to follow from this that we should expect a given “simple” psychosis to be specific to a particular organization at a particular  $M^N L$  level. — But then there can be no guarantee that such “simple” conditions will not spread their effect in a chain-reaction which would similarly unbalance other systems, and perhaps provide exacerbating positive feedback into the original system as well. Nevertheless if this postulate is true to any significant extent, then we might expect that experimental and clinical studies which rely on *correlation-seeking* procedures will produce more mystification than enlightenment on the nature of psychosis because any observable behavioural syndromes are more likely to reflect the<357> secondary chain-reaction processes than the nature of the original “simple” psychosis, or its connection with *step 2* difficulties.

358

### *Other Set-Definition Methods — (beyond Intensive and Tethered-extensive)*

So far the discussion in this section has been concerned only with the “tethered” type of extensive definition for the sets. Members have been considered as being either physically bound together, or more likely it is their representative “names” which are physically bound, and these are presumed to be in potential contact with the member elements by means of *intensively defined* calling mechanisms. We have not yet brought the present discussion back to the “bounded” type of extensive definition, but already it is beginning to become clear that any straightforward trichotomy of set-definition types may be an oversimplification. For one thing, we have just been reminded that tethered extension is likely to operate *in close cooperation* with intensive set-definition; but there are also reasons for believing that intensive definitions themselves are possibly specific to particular distances-from-source, or even from sources (plural). Such possible effects have already been discussed above in Section C6.7; but it will assist the present discussion if we recall the essential points here, and consider their likely implications for the methods of defining set-membership.<358>

For one thing it was argued that, thanks to optical dispersion of the calling-signals, the actual electromagnetic “key” pattern which such signals would present to reception sites would *vary* according to the distance which the signal had passed through the dispersive medium. This has obvious implications for an extensive definition of the sets involved (over and above the intensive “callsign” properties) because the effective target region for any particular coding-and-distortion-tolerance would seem to be a spherical shell, of specific dimensions, centred on the emitting source. [As a matter of detail however, we should bear in mind that unless the dispersive medium

359

Fig C8.1/7.

An illustration of the sort of region which is likely to be implicitly specified when two range-specific signals are required simultaneously for effective reception. In practice, the shape is likely to be much more irregular because the diagram shown here assumes unjustifiably that the medium will be homogeneous and isotropic throughout.

&lt;360&gt;

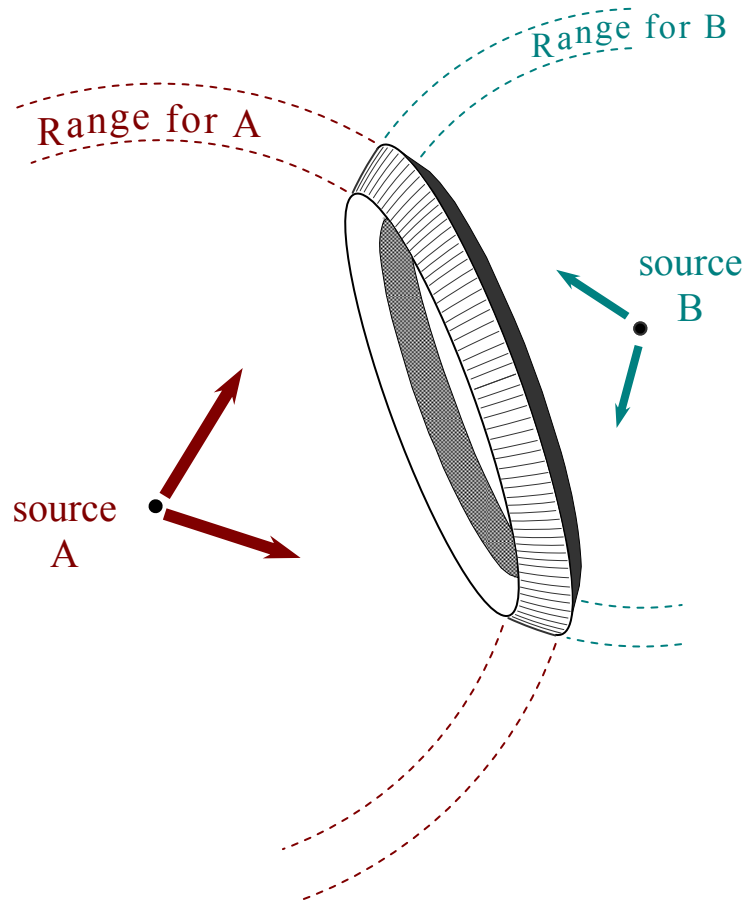

(360)

happened to be homogeneous and isotropic, the actual shape of the reception-region would not be such a neat geometrical shape. And in view of the likelihood that the bulk of any dispersion would be caused by such inhomogeneities as myelinated fibres, this caveat is hardly to be ignored. On the other hand though, we may happily interpret this concept *topologically*; and in some circumstances we might even get away with statistical approximations — though this should certainly be regarded as dubious pending an in-depth mathematical treatment of the whole dispersion issue]. Anyhow, the essential point here is that there is not only a bounded extension criterion superimposed upon the supposed intensive definition of sets, but it seems that the two processes may actually interact, and that the boundaries of effective areas may have much more intricate shapes than one might at first suppose.<359> .

But Section C6.7 went further and considered the possibility that, in some circumstances, the effective signal would be an interaction-effect or interference-pattern from two or more separate sources, whose in-phase operation is likely to have a special significance worthy of detection. Anyhow the geometrical implication for such a process is shown in Figure C8.1/7, assuming a homogeneous isotropic medium and two relevant emitting sources. Here the effective receiving-region has been narrowed down to the ring-shaped overlap of two spherical shells, and of course any case which required the interaction of any further sources would entail an even more selective target area. (As before, this neat picture is likely to be severely disrupted by inhomogeneities in the dispersive media, but the general principles should still apply).

It will be convenient to apply the term *Range-Bounded Extension* to this potential method for defining a set, whatever the number of emitting-sources involved: one, two, or fifty.

361

As it would now seem that a signal may be guided to its “intended”<sup>76</sup> destination by two largely-independent mechanisms (a code-specific receptive-site, and a range-specific “broadcast beam”), we would appear to be dealing with mutually cooperative redundant systems, both fulfilling roughly the same function. This means that the system might well be able to continue functioning<361> even if one of the mechanisms is disrupted — though we might well expect there to be some loss of efficiency as a result of the reduction in redundancy, and that this will show specific features depending on which of the mechanisms has been disrupted. Such phenomena seem likely to have some bearing on the attempt to explain psychotic symptoms, as we shall see.

362

### *Sets Defined by Barriers such as Cell Membranes*

But when we were discussing bounded extensive definitions earlier, we were more inclined to envisage the physical set boundaries as being actual physical barriers such as cell membranes. Such a view is clearly still tenable, though it will be expedient to make a clear distinction between it and the above Range-Bounded type; so let us refer to it as *Envelope-Bounded Extension*, or *Barrier-Bounded Extension*, depending on whether the boundary is seen as being complete (such as a cell-or-vesicle membrane) or merely a non-enclosing “wall” (such as the endoplasmic reticulum). It remains then to explain how such set definitions might become established, and postulate the particular purposes they might serve.

One process whereby such categorization-by-location would probably be set up is that of embryological cell-differentiation. Thus it would seem from the work on brain-mapping (see Section C5.4 above; especially concerning Hubel and Wiesel) that for the more permanent ( $M^1L$ ) parts of the brain organization, there is a ready-made orderly array of “pigeon-holes” into which incoming processed signal patterns are sorted. So no-matter whether such cells operate as a single integrated unit, or whether their essential activity is at the molecular level, in either case the cell’s overall function will be specialized and its effective processing will evidently be limited to a single restricted “topic”. It is rather less clear to what extent these orderly arrays of cells really are “ready-made”<362> by “purely” genetic means. As with other embryological developments, we should be on the lookout for shaping effects arising from early attempted usage; — orthomaturation again. (We shall come back to this point again in the fourth paragraph below, in connection with the supposedly less primitive origin of such categorization of elements in later development).

363

### *Spontaneous Clumping and its Interaction with Boundaries*

In addition to any such genetically inspired specialization within cells, we should not be entirely surprised to find a comparable type of specialization occurring *spontaneously*, very much in the same way as land use will tend to become locally-specialized *even in the absence* of legal constraints and natural geographical features (which might perhaps be compared to genetic factors). Moreover the reasons for such clumping would appear to be similar in that there are certain advantages in having particular types of entity in close proximity to each other — be they communicational entities, or economic, or cultural/emotional — so aggregates will tend to continue to build up, within limits, once they have actually begun.<sup>77</sup> Such beginnings may have

<sup>76</sup> It will, I hope, be clear now from previous discussion that this channelling of information is not to be attributed to teleological or vitalistic forces. We should rather think of such channels as evolving arbitrarily (with a large percentage of failures) and then (sometimes) being adopted by an existing system because of an apparent usefulness which the system discovers in them. Of course, once the channel has become established, then it does make some sense to talk loosely about “intended” destinations.<361>

<sup>77</sup> For theoretical considerations of the consequences, to the homogeneity of the system, of various

been inspired by genetic factors or whatever, or they might simply have occurred in any arbitrary location wherever several potentially-cooperating elements happened to occur simultaneously. If micro-pipette electrodes detect some sort of functional specialization at different sites, notably cell-bodies or nodes of Ranvier, then this would hardly be surprising even within the so-called “association cortex”, but such findings need not necessarily imply that the electrode has detected all the<363> available information at these locations, nor that the specialization is total and exclusive. Nevertheless such phenomena are clear evidence of some degree of “Envelope-Bounded Extension”, or something very like it.

364

In fact, the existence of “natural” boundaries in the form of cell-membranes and similar barriers, will presumably greatly influence the way in which the local aggregations develop — just as natural geographical boundaries profoundly influence the way in which man or beast will develop a specialization in land-use. The isolation of any given area from its neighbouring areas will increase the likelihood of homogeneity *within* that area, and its difference from its neighbours. The boundary will also act as some sort of a brake on any tendency for the aggregate to grow uncontrollably at the expense of the system as a whole; (and it may well be that this formal similarity to the problem of cancerous growths is no mere coincidence). Such restriction on potential communication also brings us back to Ashby’s important point that “connections” within the brain should be severely limited, and not superabundant as one might suppose.

Just what sort of local homogeneity should develop will presumably depend on various factors including the ratio of locality size to the effective range of signals within the locality. Thus we might expect the operation of large localities, such as the Purkinje cells, would<364> be significantly different from the operation of small localities. The degree of isolation will presumably also be of considerable importance (and subject to manipulation): excessive isolation would effectively exclude the locality from the general system, while vanishing boundary-effects would of course remove the special feature we are considering.

365

Coming back then, to the question of cells which are supposedly already pre-organized by genetic means, it may well be that there is no *strong* influence brought to bear to determine what specialization the cell should adopt — but that this would not usually be necessary, since only slight “hints” from genetic, potential-usage, or near-neighbour sources would generally suffice to steer development in the “right” orthomaturational direction. For regions of the brain where there is no predictable pattern to such “hints”, then we will presumably find no detectable regularity of function between individuals; hence the so-called “association areas”.

### *Consolidation into LTM, and its Breakdown in Psychosis*

[NB] We have by now distinguished at least four different basic methods which the brain might plausibly use to establish which elements belong together in “sets”. Post-learning “consolidation” into more suitably organized forms of memory would seem to entail the ability to reorganize such sets from one type of physical embodiment into one-or-more alternative form. It seems likely, for instance, that this is the sort of activity which results<365> in the conversion of Short Term Memory into Long(er) Term Memory — a process which can be sabotaged by bilateral hippocampal lesions, as in the case of a particular patient “HM”, (Scoville and Milner, 1957; Milner, 1966; Kimble, 1969; Milner, 1970), alias “Mr Henry” (Iversen, 1974) — though one should be cautious about assigning a detailed role to the hippocampus on this evidence, or in attributing this effect to *all* concept-consolidation phenomena.

366

---

simple assumptions about inter-element affiliation: see Goel (1970), Goel and Leith (1970), Leith and Goel (1971). Similar considerations also apply, of course, to phase theory in physical chemistry.<363>



So far then, broadly speaking, we have considered four different types of set-definition: three varieties of extensive definition plus the intensive definition — though we should recall the argument that intensive definitions are likely to be complicated by range-effects arising from optical dispersion and hence probably confounded with the Range-Bounded Extension type of definition. Anyhow, bearing in mind that such mechanisms are likely to be operating pluralistically in parallel, we now have some basis for postulating the type of malfunction which could result in psychotic behaviour:- any breakdown in extensively-defined set-organization would be rather like emptying one's filing-cabinet onto the floor and tearing the pages out of the diary! Assuming, that things were properly labelled (i.e. intensively defined) then one could, in principle, carry on with considerably reduced efficiency — on the “Seek and ye shall find” basis.<366>

This example emphasized pre-existing “files”. Alternatively or additionally we might consider what our plight would be if *no new files or lists* were to be allowed in any sort of reliable extensive form (even though we might be allowed access to existing files). Here again, some sort of coping behaviour might be possible, but our performance would clearly be seriously impaired. Moreover we may presumably envisage various degrees of such breakdown in both cases, so that we should expect different gradations in the symptoms — or even major qualitative differences as critical thresholds are reached. (Incidentally we might perhaps also expect some impairment of performance from the opposite extreme of too rigid a file-structure).

Another noteworthy point is that such breakdowns *need not be universal*, applying to all realms of the patient's thought, (though in some circumstances they might be — e.g. in response to some generally active toxic agent). Thus a disruption effecting language and logic performance in the left hemisphere, need not necessarily have any direct bearing on musical ability in the right hemisphere; or different subject-material might be differentially effected even if, from the macro-anatomical point of view, they were stored at the same site. In particular, a disruption at one  $M^nL$  level might well occur in isolation from the performance at other  $M^nL$  levels; and this is a point which entails some important consequences:-<367>

#### *Symptoms varying greatly according to which “ $M^nL$ ”-level fails*

Let us refer back to Table C5.4/I and work down the  $M^nL$  scale considering the types of symptom which are likely to result from a deficient extensive-definition capability at each level. Such a failure at the  $M^3L$  level would be commonplace, and indeed we might doubt whether the  $M^3L$  level exists at all; but anyhow most people seem to manage perfectly well despite this. Failure of  $M^2L$  “formal operations” brings us to one type of symptom often associated with psychosis, though it occurs in other circumstances as well: this entails a failure of logical or mathematical coherence — in a degree considered undesirable within the culture concerned (after all, no man can match a computer in some features of this skill). Such lapses from “secondary process thinking” (to use Freudian terminology) are commonplace of course; even for “normal” people they occur during dreaming, under intoxication, fatigue, and pressure of events. Those people having a chronic deficiency here but not at any lower level, would quite likely pass as “normal” in fact; though presumably they would be classified as “having a low IQ” or as being innumerate, or perhaps even credited with socio-economic class attributes such as “semi-skilled” or “unskilled”. Indeed this is a feature which we might do well to investigate in some detail, though it lies outside the scope of this present work.<368>

Failure at  $M^1L$  would be more serious, producing behaviour which most people would regard as bizarre — such as devising *ad hoc* sets of objects with scant regard for the culture's view of which objects “should” belong together. (Here, as has often been remarked, there is a tenuous distinction between “madness” and “creativity”. After all, sometimes the culture could benefit from a re-drawing of its conceptual boundaries). However there is nothing very creative in the

367

368

369

more syncretic thought of the more severe cases. Such scant following through of mere shreds of association suggests a serious lack of the ability to manage sets — i.e. to manage lists of more than one object at a time; and this tends to confirm the suspicion that such patients are just making do with unsupported intensive definitions, whereas the normal person would make considerable use of one-or-more type of extensive definition to support the process — both regarding grouping entities found useful as a set in the past, and also on an immediate Short Term Memory basis.

Even more serious conditions are likely to arise from defects at the  $M^0L$  and  $M^{-1}L$  levels. The  $M^{-1}L$  case scarcely belongs in our present discussion because its organization is probably different, with perhaps no bearing on the intensive/extensive issue in its present form; and any developmentally-important defect will probably be of a non-psychological nature — acknowledged as “organic” by the medical profession.  $M^0L$  failure would constitute an inability to comprehend objects as<369> such — a non-acquisition (or loss) of the subconscious realization of the mathematical group-like properties of those significant ensembles in our environment which we call “objects”. Because objects are, on the whole, remarkably consistent in displaying their properties in a comparatively simple form, it will be most unlikely that such learning will not occur (or be lost) unless physical  $M^0L$  handicaps render such lessons virtually inaccessible. Such a blockage at the senses or their nerve-tracts, or indeed in the would-be set-handling mechanisms of the brain, will presumably leave the unfortunate individual in a vegetative state, as depicted in the film “A Day in the Death of Jo Egg”; and borderline cases such as deaf-and-blind babies need most carefully organized experiences of touch, texture and olfaction if they are to have anything like a normal development (Tyrrell, 1977). Once basic concepts of this type have been achieved, it seems hard to believe that they could be lost again in view of their presumed stability — unless perhaps under extreme trauma and sensory-deprivation, or an elaborately rigged environment of ephemeral dissolving pseudo-objects! Regression back down through  $M^0L$  therefore seems unlikely.

Here we have been discussing *objects* (as semi-rigid geometrical entities) as if this were the only type of development which depended directly on the  $M^0L$  sensori-motor stage. This may be a somewhat simplistic view, considering that interpersonal relationships are<370> also developing at the same time. Of course these relationships may well be interpretable in terms of objects — after all, as we have seen earlier, one’s self is a key prototypal object against which to assess other objects, and parents constitute other key objects. But it is not difficult to see that there will be a qualitative difference, at some stage, between objects of the more geometrical type and those of the more human type; and this will presumably mean that there is a possibility that one type might come to malfunction even though the other might develop properly. There is some possibility then, that we may have here a vulnerable developmental point at which an inadequate or inappropriate set-organization could lead to *autistic* or *psychopathic* tendencies. This however is a side-issue, and I shall not pursue the matter further here.

#### *Addressing the correct $M^0L$ in Daily Life — an important skill*

Another logically possible type of malfunction within the brain’s set-organization is what we might call “meta-linguistic confusion” — the incongruous lumping-together of elements which properly belong to *different*  $M^0L$  levels. Thus sharpness, a quality of primary perception properly belonging to the interface between  $M^{-1}L$  and  $M^0L$  might become reified and be treated mentally as if its internal coding were that of an actual object (belonging at the  $M^0L/M^{-1}L$  interface) — and all this without any ( $M^2L$ ?) awareness which could render the activity into an acceptable *metaphorical* usage. Similarly the confusion could occur one step further up the  $M^0L$  scale, between an *object* and a *set* (perhaps the set to which it<371> properly belongs — “this slug” versus “slugs in general”).

During development, such meta-linguistic confusion is probably natural, inevitable, and commonplace (as implied by the mechanisms postulated earlier in the present section, in relation to Figure C8.1/4; but normal development presumably brings a fair measure of mastery of such mysteries, through closure-seeking processes and the establishment of a specialized “administrative” set-organization whereby elements are generally attributed to their proper  $M^{\text{L}}$  levels. In principle this could be effected by the establishment of extensive definitions for the respective levels; but in view of the apparently small number of such sets, and their very large membership, it would seem to be a more economical plan to use some form of *ad hoc* intensive definition for this purpose — and in the circumstances this could well take the form of a “tag” system such as those discussed previously in connection with punishment/reward, affect, and feelings of familiarity. Alternatively perhaps there is no such explicit administrative set-structure at all, and its function is adequately implied by the massed membership-patterns of the ordinary sets, evolving in a “proper”  $M^{\text{L}}$  way, in the light of experience.

It is of some importance to pay special attention to possible differences in set-organization for different aspects of mental activity. In assessing clinical<372> evidence with a view to finding meaningful categorisations amongst symptoms, it will be potentially very useful to have in mind likely differences in the underlying mechanisms, because any separate anomalies in these mechanisms might reasonably be expected to be the cause of separable behavioural abnormalities — or at least different emphases in the behavioural patterns. One such possible difference in mechanism is that between “administrative” and “ordinary” sets, which we have just been considering. Another is the distinction according to subject-matter; and another is the important distinction between  $M^{\text{L}}$  levels, which also raises the question (discussed in Section C3.2 and depicted in Table C5.4/I) of whether the same material substrate is used for all  $M^{\text{L}}$  levels, or whether for instance the lower levels operate wholly or partly within the more ancient and primitive parts of the brain, such as the tectum. It is not necessary here for us to arbitrate decisively between such alternatives, but the existence of a conceptual framework which poses such choices might well make it easier to devise more plausible interpretations of clinical observations than those currently offered.

### Summarizing Section C8.1

To summarize the discussion of this section:- In general we have been exploring the implications of the supposed existence of alternative physical embodiments of mental set-structure — the more fundamental intensively-defined type, and at least three types of<373> the more instantly-accessible extensively-defined variety. Some consideration was given to the question of how one type could be “translated” into another, though it will be clear that the treatment of the subject was not exhaustive (such as to offer a formal internal closure on the issue), and indeed such an attempt would seem to be premature pending a detailed quantitative investigation of the biochemical and physical issues thought to be involved. In particular, the point raised about the likely observational confounding of Range-Bounded Extension effects with those of Intension (because of optical dispersion, especially if this is a variable) is likely to create great difficulties for any detailed systematization of the theory; though of course it might be possible to demonstrate that this is a non-problem in practice. Anyhow the essential point here, for present purposes, was to give a feel for the sort of processing which might be taking place, and how this might manifest its malfunctions at the clinical level — a matter which we turned to in the concluding part of the discussion.

[A further remark, on the specific issue of the suspected range-related nature of intensive definitions, might usefully be made here. We have seen that even though a molecular “label” may be receptive to a given signal-pattern after it has traversed optical path  $x$ , this will be no guarantee that it will be receptive to “the same” signal when it has travelled a different<374> dist-

ance y.<sup>78</sup> This leaves us with a further question:- Does the “x-distance” version of label have a better chance of evolving into the “y-distance” version than any other random label which happens to be present? And if it does, is it likely to evolve via a gradual Lamarckian progression — perhaps as it gradually shifts position; or will the change take the form of a sudden mutation? The trouble with the Lamarckian gradualistic conceptualization is that it is difficult to devise a mechanistic non-teleological explanation of how the process might occur — except perhaps in exceptional “freak” circumstances when the natural course of chemical progression just happened to coincide with rather involved biological needs, without requiring any guidance from feedback mechanisms.

As for the primary question which implicitly asks whether there is any point in evolving an “x-distance” version when it is really a “y-distance” version which we will ultimately need, the answer seems to be twofold:- Firstly there probably is some advantage — some “transferability of training” — but no absolute advantage from the molecule’s own private point of view. Secondly, and more importantly, the advantage which might be<375> gained from such approximation to the optimal should be seen from the viewpoint of the system as a whole, rather than as a “promotion-system” for individual elements. In this light, we should see the advent of roughly-appropriate mechanisms and procedures as creating a suitable environment for further progress, by focussing the developmentally-influential ongoing activity onto more relevant transactions. But once the interim structures have served this purpose, aiding the evolution of still better structures, it is more than likely that they themselves will be bypassed as obsolete, *C’est la vie!*

-why?

376

Even if the structures discussed here turn out to be purely fictional, it will perhaps still be worth posing similar questions for any other structural evolution which seems likely to be occurring; — and considering whether the same suggested answers are pertinent in the new context.]

To conclude this sectional summary, we should recall several general principles of operation which have been considered as likely to apply. Firstly *parallelistic pluralism*: there are likely to be a number of alternative methods and structures for many tasks within a biological system, especially within the mental activities of the higher vertebrates; and these alternative systems should be considered as potentially operating in parallel — and perhaps in cooperation. Sabotaging one will therefore not<376> necessarily stop normal functioning, though it might impede its efficiency; so traditional notions of “the controlled-and-designed experiment” should be evaluated with some caution.

377

Secondly, although there may be such alternatives, some types are likely to be much *more common* or more readily implemented by the system; so we may often be justified in ignoring some-or-all of the theoretical alternative varieties. Thirdly, as we have just discussed parenthetically a couple of paragraphs ago, some alternatives may serve as *evolutionary staging-posts* — a practical necessity for the proper development of the system, but expendable in themselves. It may be that they themselves undergo the change “required” for the system, or the changing function may pass to other physical subsystems. Fourthly, and finally, such changes are seen as having a *basically random* fortuitous inception — on essentially Darwinian lines — and the apparently teleological nature of such “guided” developments is seen as stemming from a selection process, which is indeed guided, but on a post-hoc basis — judged on performance.

<sup>78</sup> There may well be more to this matter of optical distance than we would expect at first sight. Thus electromagnetic distinctions between “near field” and “far field” may well be involved — and/or the question of whether there is chemical-bond contact of any sort.<375>

## C8.2 Interpretations of Clinical Schizophrenias and Other Conditions, on the Basis of this Theory

In any attempt to devise a generalized theory to account for a wide and poorly integrated area of clinical phenomena, it is likely to be a useful policy to seek out some single work which offers a reasonably<377> balanced and comprehensive yet condensed coverage of the whole field. As well as essential description, this should include a balanced outline of existing partially-successful theories. For our present purposes, an eminently suitable survey of this type is available in the form of Chapman and Chapman's book: *Disordered Thought in Schizophrenia*, (1973); and page or chapter references during this section will refer to their work unless otherwise stated. Accordingly we shall now look at various distinguishable themes which arise within their book — often from the differing viewpoints of individual workers in the field — and try to reconcile them with the reductionist approach which has been discussed above. We may consider the themes in their approximate order of apparent importance, as judged by their salience in Chapman and Chapman's survey:-

378

### (1) Faulty clusterings of concepts.

This includes the formulation, traceable through Stransky and Kraepelin of a “loss of inner unity of thinking, feeling, and actions” (Chapman & Chapman, page 8), such as not sticking to the point; or (page 9) citing Bleuler, the patients “lose ... logical ordering of their trains of thought. ... familiar associations ... are absent”, while “the most unnatural combinations ... are formed, because their incongruity is not perceived ...”. Subsequently, in Chapter 5, Bleuler's (1911/1950) theorizing is discussed in<378> some detail as the concept of “Broken Associative Threads”; though the authors complain (page 110) that “Bleuler never explicitly defined ‘associative thread’ ..[but] implies that [it] .. is not an observable event, but a construct ...”.

379

In the light of our foregoing discussions, these observations and comments make interesting reading. Taking the authors' criticisms about observability first: If the theories developed in the present work are anywhere near the truth, then it is small wonder that Bleuler was unable to hazard any very credible guess as to what the “threads” might be in material terms, nor any details concerning how they might operate. And even if he had, then he would have been in an even worse position than we are now when it came to suggest ways in which such a mechanism might be directly *observed*. Clearly then, these threads would have had to be *constructs* in this sense.<sup>79</sup> But it is one of the arguments of the present work that this need not mean that the construct is necessarily limited to being a mere convenient fiction (Section C1.1), though this *could* be so. After all, as it is argued there, there is a case for suggesting that even our most respectable “observations” are fundamentally still constructs in the strict qualitative sense — though well separated from *acknowledged* “constructs” on some scale of corroboration and hence of indubitability.<379>

Not that we need accept Bleuler's “threads” at face-value, but it should now be apparent that a comparatively trivial translation can be made into the conceptual framework of the present theory of “call-signs” (intensive definitions of *one type*) and physically constrained sets (extensive definitions), both of which may be construed as having some functional and topological affinity with the “thread” concept. Clearly the present account does attempt a more detailed development, but this is not to belittle the pioneering conceptualizations of Stransky, Kraepelin, Bleuler, and others.

380

If we accept the plausibility of the conceptualizations of the previous section, then we will not find it difficult to attribute the patient's faulty thought-associations to a break-down in one-or-

<sup>79</sup> like the formal status of the “tape” concept (Chapters A1 and A3, above), before any structural interpretation was attempted.<379>

more of the postulated mechanisms by which the brain is supposed to represent *sets*. To be more specific, it is probably a failure of Tethered or Range-Bounded Extension — leaving the patient to make his way, as best he can, with the more primitive and ubiquitous Intensive-type of definition for his sets. This would seem to account for his “default solutions” in the form of syncretic thought (supposedly based on intensive definition), and arguably also for any “overinclusion” which he might exhibit (Chapter 9). Similarly any “Excessive yielding to Normal Biases” (Chapter 6 ) might also be seen as essentially the same mechanism; and the same again with the overusage of (Tag-using Intensive?) emotional<380> associations, as expressed in the passage from Jung (1906) quoted on page 226: “The pure laws of association play quite an insignificant role when confronted with the unlimited power of the emotional constellation.” All these manifestations may be seen as tendencies inherent pluralistically in the normal individual adult, but which come to the fore when the controlling and order-enhancing influence of extensive set-definition fails to operate properly.

381

Some interesting points are raised by the view that the schizophrenic might, in various ways, be showing signs of regressing back to an earlier stage of development, (Chapter 10). Here the emphasis seems to be on the loss of the ability to think abstractly — a matter which we will return to below under item “(4)” — but presumably any type of regression, anywhere on the  $M^iL$  scale, would come under the same heading. In general, when the individual loses some of his repertoire of set-handling ability at one of these levels (which we will call the “ $M^iL$ ” level), then as an additional-or-alternative strategy to making-do with syncretic thought at that level, he may happen to try reverting to some well-tried mode of thought belonging to the  $M^{i-1}L$  level; and this is clearly just a new form of words to describe “regression”. (In fact any reversion to syncretic thought should also be regarded as regression — indeed it might be argued that it is itself an  $M^{i-1}L$  phenomenon;<381> though such fine distinctions do not materially alter our present argument).

382

It is worth noticing that schizophrenic and regressive conditions cannot really be identified with normal childhood stages, nor with the mental orientations arising normally in more primitive cultures. Chapman and Chapman (page 215), in discussing the study by Bolles (1937), re-state one difference as: “The children, unlike schizophrenics, were able to shift from one approach to another in solving a problem and were able to disregard differences and grasp similarities.” Assuming that the assessment of “comparable mental age” (page 214) is above serious reproach in the light of the present theory, this is likely to indicate that the schizophrenics have an additional deficit — in the sets which organize the sets-under-consideration, a matter which we will discuss below under “(2)”. In any case we cannot ignore the fact that schizophrenics have bouts of comparative normalcy in which, presumably, the set-structure makes a partial recovery for long enough to operate on *still-existing* higher-level *elements*, such as schemata for abstract thoughts, which would simply not be accessible to children. Similarly, different background histories of experience are likely to produce different numerical weightings amongst the codings for different categories of element, and hence influence the “strengths” of mental-association differentially. Thus: “The younger children probably learned the stronger<382> meanings of words earlier, since they are the more common meanings” (page 220, discussing Chapman et al (1961)).

383

We have seen that a large number of the symptoms of schizophrenia may plausibly be attributed to this syndrome of a “faulty clustering of concepts”, which means apparently that some aspect of the individual’s ability to handle sets has somehow broken down. In fact we have so far concentrated on the simpler variations on this theme, leaving others to be discussed below as special cases. The type which we *have* looked at here seems to centre on one  $M^iL$  level at a time, though it is by no means clear whether actual patients customarily show this same simplistic bias; and it is more than likely that such an impression is merely an artefact arising from the way

we organize our collection and analysis of data — using *collective* populations of subjects, and expecting our data to produce *isolated orthogonal dimensions* at arbitrary levels of resolution chosen by *us*. Nevertheless, if we take this impression at face value, we are left to consider which single  $M^{\text{n}}L$  level or levels suffer from this failure, and produce their respective symptoms — some of which will be classed as “schizophrenic”, while perhaps others will not. In fact this issue has already been dealt with in Section C8.1 where it was suggested that it was the  $M^{\text{1}}L$  level which produced behaviour sufficiently bizarre to be regarded socially<383> as schizophrenic, while not yet so debilitating as to be regarded as physical or vegetative. In Piagetian terms then, this places the more essentially “schizophrenic” phenomena within the orbit of *Concrete Operational* failures: an inability to manipulate objects, symbols, and social-objects in a coherent “group-like” fashion involving set-manipulation, though rote performances and pre-set schemata might seem to work adequately in isolation.

Of course it might be pondered that such a state at one  $M^{\text{n}}L$  level could precipitate a similar deficiency at one-or-more other levels — resulting in a confounding of symptoms within the one patient. (And this might occur even if just one  $M^{\text{n}}L$  level were a sufficient initial cause for schizophrenia). In such circumstances, it would be somewhat misleading to state baldly that single simple  $M^{\text{n}}L$  phenomena were the cause of the whole syndrome of symptoms, even if this were strictly true in an indirect way.

(2) *Shakow’s Major and Minor Set,  
and his anomalous “Preparatory Interval” experiments.*

Shakow’s formulation of schizophrenia, (Chapter 12, Chapman and Chapman), attributes the symptoms to a “loss of major set” — where the word “set” is here used in the psychologist’s sense of “mental set” toward a particular subject-matter, and not the mathematical sense of a collection of entities which we have been using above. (This is perhaps just one of those unfortunate clashes of<384> terminology which is bound to arise from time to time when once-separate disciplines start to overlap. One might well argue that there is some common element of meaning between the two usages, but that does not help us much when we are trying to delineate precise meanings, especially at the exploratory stage as at present. Nevertheless, both usages are so well ingrained in their respective fields, that it seems prudent just to make the best of the situation — differentiating the ambiguous word “set” by adjectives such as “mental” or “mathematical” wherever the distinction is not clear from the context).

385

In Chapman and Chapman’s words: “Shakow defines ‘set’ as a state of readiness to respond to a particular stimulus and ‘major set’ as a state of readiness to respond appropriately, that is, in a way that facilitates adaptive behaviour” (bottom of page 244). These definitions are couched in an operationalist-oriented terminology which is of rather limited value for our present objective of postulating structure, but they do serve as a useful benchmark. ‘Minor’ or ‘Segmental’ set appears to be left simply as meaning “Non-major set”; thus (bottom of page 248): “Examples are [1] apparently aimless response, [2] response to isolated aspects of the task, [3] repetition of previous responses, and [4] response to irrelevant and internal stimuli” — thereby accounting “for the positive symptoms” of schizophrenia.<385>

It will be instructive to look at each of these items in turn, and attempt to give interpretations, in structural terms, in the light of the present theory.

386

Taking [M] ‘major set’ first, we may reasonably suppose that a “readiness to respond appropriately” will depend crucially on the adequate availability both of task-relevant schemata at the Concrete-Operations ( $M^{\text{1}}L$ ) level and also of situational-and-social schemata at the same or higher levels. Moreover, for efficient execution of anything but the most trivial of tasks, such schemata would seemingly have to base their organization on some sort of extensively-defined (mathematical)-set structure — and mere intensive-definition would not really be adequate. So if

this *is* what ‘Major Set’ entails, or largely entails, then its loss could be confidently expected to produce schizophrenic symptoms, and indeed we could then reasonably identify the situation with the failures discussed above under “(1)”.

Looking next at [2] “response to isolated aspects of the task”; this could be seen as a *failure to integrate* the various aspects of the task into one whole extensionally-defined set, and *maintain* it in functional form for long enough to make proper use of it. This could take the form of ■ failing to form an integrated inner mental *perception* of the task or the objects involved in it, or it could be ■ a failure to marshal the<386> relevant *action*-orientated schemes appropriately, but it is perhaps more probable that the failure would be ■ general and encompass all such mathematical-set transactions, to a greater-or-lesser average extent. Accordingly, wherever there is a non-materialization of an effective mathematical-set, its role is likely to be taken by some arbitrary would-be *member* of it<sup>80</sup>. But a *member* is not the same thing as any *set* it might belong to, and if the individual proceeds on the misleading assumption that it *is* the same, then we might well expect his behaviour will reflect this by his only taking cognizance of detached *parts* of what we would regard as the total situation. (Incidentally, this could also be taken as one explanation for the phenomenon of “narrowed attention”).

Two paragraphs back, the distinction was made between *task-relevant* schemata (at the  $M^1L$  level), and *situational-and-social* schemata (which were seen as either  $M^1L$  or  $M^2L$  phenomena, and quite possibly both).

Anyhow, the essential point here is that the very existence of a “task”-or-aim is often simply a particular aspect of the ongoing social situation — which normal people will usually take for granted and categorize correctly without conscious thought; whereas the faulty mechanisms within a schizophrenic’s mind are likely to<387> make the same mess of such socially “obvious” things, as they would for detail of the task itself. This would seem to account for two more of the symptoms attributed to ‘Minor Set’:- [1] “apparently aimless response” and [4] “response to irrelevant and internal stimuli”. After all, when one comes to think of it, it requires a considerable amount of developmental sophistication to divine what (if anything) one’s “proper aim” should be within a social context, or which stimuli are to be considered “relevant” given a particular complex context in which it is often *social convention* which defines what should be regarded as salient. If the patient’s mathematical-set-structure is unable to build up an adequate model of the ongoing social situation, in the terms which the culture expects, then he will assuredly wander into gross irrelevancies. Even if (like a computer) he were able to handle the task material itself with perfect proficiency, he would still need an absurd amount of guidance (like a computer!) if he is to avoid perpetrating “idiotic howlers”; but of course such proficiency might always desert him too, and in any case there is no guarantee that the guidance could be implemented.

This leaves [3] “repetition of previous responses” (now encoded internally). This may be regarded as similar to divining the social situation, as discussed in the previous paragraph, in that both entail some sort of monitoring and control of more basic action-oriented schemata. The emphasis is<388> now *perhaps* rather more introspective, on the lines of: “What are my own aims? And am I making any progress towards them? So, what is the next step?” However if we choose to claim that these aims and self-monitoring skills derive ultimately from the culture<sup>81</sup> — then the distinction, *if any*, becomes rather tenuous.

<sup>80</sup> — some of whose molecular elements might (in happier times) be capable of mutating into the nucleus of just such a set, on the lines discussed in connection with Figure C8.1/4, above

<sup>81</sup> — or perhaps even if they are merely due to experience based on the physical inevitabilities of the environment



[1+4+3] In any case, it seems plausible to attribute such self-monitoring activities to the workings of the postulated mathematical-set structures, and thus essentially just another example of the same basic phenomenon — though the actual sites of the relevant ultra-micro structures might differ for the different aspects of the patient’s overall repertoire, so the severity of malfunction need not be the same for the various symptoms, nor for the various **M<sup>n</sup>L** levels which could be involved.

We should not pass by this phenomenon of “repetition” without remarking on its apparent formal similarity to Piaget’s “Circular Reactions” in infants (Chapter A3, above). Not that we need read much into such a similarity, but some such schizophrenics may well not be properly aware that “I ha Or if the patien action is rewar logical-or-socia

390

Fig C8.2/1. At this point, the original 1978 version of this work replicated Rodnick and Shakow’s (1940) diagram of “Mean reaction times of twenty-five schizophrenic and ten normal subjects at the various preparatory intervals of the regular and irregular warning procedures”.

Partly for copyright reasons, those experimental findings have here been reorganized and somewhat simplified such as to illustrate the present discussion a bit more clearly.

The dark-blue dotted line at the bottom is a recent addition. — RRT, 2006. <390>

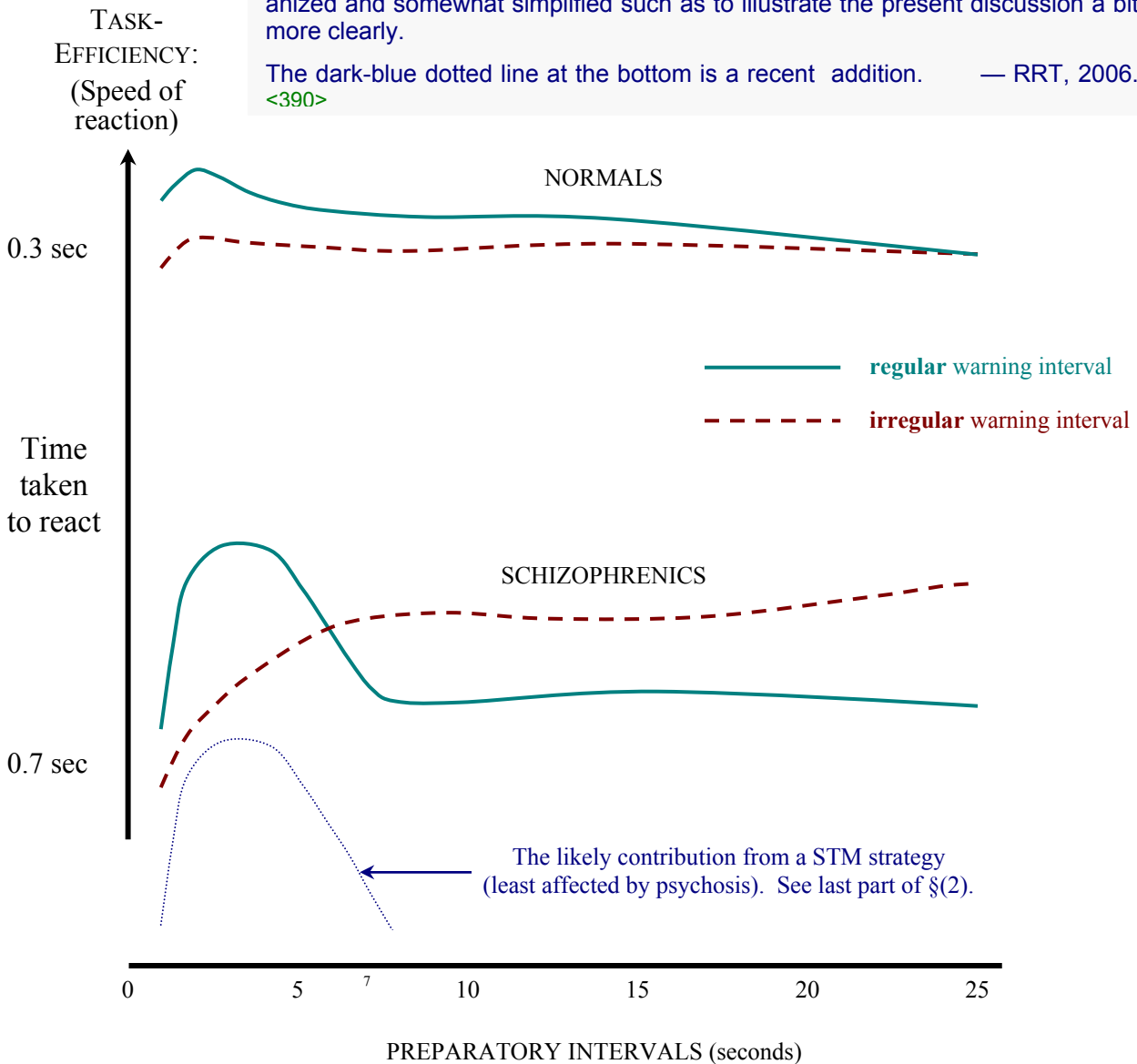

(390)

### Reaction speed, apparently depending on facility in handling mathematical sets

We may turn now to Shakow's findings of an anomalous pattern of reaction-times for schizophrenic patients (pages 244-246, Chapman and Chapman), see Figure C8.2/1.<390> In these experiments there were two stimuli: a preliminary bell, and then (1 to 25 seconds later) a light to which the subject was expected to respond as quickly as possible. If the subject had any way of knowing how soon to expect the light after he had heard the warning-bell, then one might expect him to be able to use this knowledge somehow such as to give him a quicker reaction when the light-signal duly arrived. Thus if a given trial occurred within a block of trials in which this "preparatory interval" was (say) 10 seconds for each case, then the subject might be able to make some use of the realization that this was the case; whereas if there were no such regularity in the length of the preparatory interval within a block of trials, there would seem to be no such helpful knowledge available for utilization.

391

If, for the moment, we look only at the result in Figure C8.2/1 for preparatory intervals of more than 6 seconds, then we notice that the normal subjects do indeed perform better for the "regular" presentations (except when the difference vanishes for the very long 25 sec. delay); but the schizophrenics actually performed *better* for the *irregular* presentations! Meanwhile the performance for these same schizophrenics *was* slowed down *as expected*, but only for those cases in which the preparatory interval was less than 6 seconds — and moreover a plausible explanation for this "crossed-graph" inconsistency was offered by Zahn, Rosenthal, and Shakow (1963). This explanation (page 247, Chapman and Chapman) traced some of the mental-set (as to expected-delay)<391> back to the delay encountered in each *immediately preceding* trial,<sup>82</sup> rather than to any constant value which the block-as-a-whole might have; and furthermore it seems that schizophrenics are *more inclined to use this strategy*. In the context of our present discussion, the important questions to ask are now: "What do we suppose is actually happening in micro-structural terms? And why should the structural configuration of a schizophrenic's brain favour one strategy, while that of a normal brain will favour another?"

392

In fact it would seem that we need not look very far because this phenomenon can be seen in terms entirely consistent with those used a few paragraphs ago. The normal subject's thinking will be ordered by set-structures which entail (i) the logico-social concept of the experimental *trial-block* as a meaningful entity existing over an extended time interval, and (ii) the logico-social concept of a *random mix* in which it is futile (or even counterproductive) to expect consecutive elements to be alike. On reflection, we can see that these concepts are by no means so trivial that we can merely take them for granted; and indeed their proper use is probably beyond the powers of a schizophrenic precisely because he will have troubles with mathematical-set structures, especially if he has<392> to hold them over the time taken for a trial-block to be completed.

393

The type of set-failure which we have been considering here will presumably relate to "monitoring-or-controlling" sets; but we should recall that we were earlier concerned also with the supposed "action-oriented" sets and their embodiment in action/perception schemata. If, in general, we expect the schizophrenic to be having difficulties with these sets as well, then we might expect to find evidence for this too somewhere in the graphs. In fact it is easy to see from the graphs in Figure C8.2/1 that the average performance-rate of the schizophrenic is about half that of normal subjects (as mentioned in passing on page 244, Chapman and Chapman), and it seems reasonable to attribute this to an inefficient action/perception set structure.

But there are some grounds for suspecting that we can infer still more from Figure C8.2/1. The Zahn *et al* (1963) explanation accounts for the [increasing efficiency-with-delay in the](#)

<sup>82</sup> a strategy which just happens to pay off for the longer delays, given the particular experimental design.<392>

“irregular-presentation” curve for schizophrenics, and with about the same sort of changes in gradient and curvature as shown on the figure — provided we are to trust the *consistency* of the ordinate speed-scale as we move left-or-right along the abscissa<sup>83</sup>. It rather looks then, as though the *absolute* values of the speed-ordinates might be reliable guides to underlying<393> phenomena. If we accept this argument, at least provisionally, then we might well ask what significance should be attached to the large “peaking” of performance at about 4 seconds delay for the regular/schizophrenic curve, and its much smaller counterpart at 2 seconds delay for the regular normal curve.

394

#### Two types of time estimate, with crossover at about 7 sec — implications in set-manipulation

This raises a number of diverse thoughts of a rather anecdotal nature, which I have no intention of developing very far here. However they may suggest some interesting lines of investigation, so I shall at least place them on record. To start with, there is the undocumented observation that computer-users operating an interactive tele-type terminal will normally be quite happy to wait for *up to 10 seconds* for the machine to respond, but any further delay is likely to cause irritation and impatience, or at least a conscious awareness of the delay. Next we might compare this to the supposed time-span for Short Term Memory which, judging from Wickelgren’s (1970) graphs, would seem to have a half-life of about 12 seconds, though perhaps a more generally acceptable figure would be around 7 seconds. One also gets the (perhaps misleading) impression that it is more difficult to make reasonably accurate estimates of time intervals greater than about 10 seconds, without resorting to such conscious and artificial devices as *counting* the estimated seconds. Accordingly, one might be forgiven<394> for suspecting that there is something qualitatively different available for processes which do not last much longer than about 10 seconds, and that this something may be intimately bound up with the recognized phenomenon of Short Term Memory (Wickelgren, 1968; Peterson and Peterson, 1959; Posner and Rossman, 1965).

395

This of course raises some questions about the role and nature of “biological clocks”. Concerning this I would suggest (i) that there *may* be “purpose-built” *slow transmission-lines*: non-TEM nerve-fibre modes (see Part B, above), *or else* linear molecules (reminiscent of those depicted in Figures C6.7/3 to C6.7/6, but without the encumbrance of logical gates along their length, so that a signal will traverse the path unconditionally, though subject to a more-or-less predictable delay); and (ii) that there is likely to be a definite *upper limit* to the delays which could be modelled in these ways without the use of a more elaborate mathematical-set structures such as various types of “rehearsal”, and (M<sup>2</sup>L?) counting procedures — each of which would probably have a practical upper limit also.

Anyhow, we might at least reasonably expect that the one-to-seven second delay intervals might be easier to embody into a useful schemoid *somehow*, thus accounting for the “peaking” of performance; and that<395> this might well be of extra benefit to schizophrenics, if only because it leaves them with a technique which is less adversely affected than others which they might otherwise have had to use.

396

Concerning the question of explaining why the same does not apply in the case of “irregular presentations”, it rather begins to look as though *for these short delays* there is a whole mechanism left more-or-less intact despite the schizophrenic condition, and that under these circumscribed circumstances the schizophrenic *is* able to benefit from the regularity of presentation in the same way as the normal subject — (though still subject to the *overall* slowness of reaction which we discussed earlier). In other words, this could be taken to support a view that there is a

<sup>83</sup> and not *just* trust it to have the right comparative relationship with other values at each different “preparatory interval” value

*pluralistic choice* of mechanisms capable of taking advantage of the block-regularity when this exists, but that one of these mechanisms can only work for the shorter-delay conditions. And if we accept that there are likely to be two or more moderately-autonomous mechanisms, then we might reasonably expect that in the normal individual each such mechanism will tend to specialize in some particular function. One (or more) is bound to be involved in the more-or-less permanently established schemata which presumably constitute “Long Term Memory”, while other likely roles for other such mechanisms will involve Short Term Memory-and/orAttention, or Consciousness (Popper’s “World 2”: Chapter A1, above).<396>

Given such postulated alternatives with moderate autonomy, then it would not be altogether surprising to find cases in which malfunctions had affected them *selectively* — leaving one (or more) intact despite disruption elsewhere. In the Shakow studies it seems likely that it is the more STM-oriented which has escaped serious disruption; but this need not be taken as representative because it is easy to imagine that if any of his would-be subjects had been suffering from such a disability, then he might well have found it impossible to get any sensible laboratory-oriented responses from them at all. So it may well be that any patients suffering from this debility, alone or in combination, tend to be overlooked in systematic studies of schizophrenics. Indeed such patients could conceivably be classified as suffering from some other clinical condition, and not be regarded as “schizophrenics” at all. Anyhow this may serve as a further pointer to the possibilities of subcategories within and across apparently-adequate clinical classifications.

### (3) *Loss of Abstract Thought and Logic.*

During Section C8.1 above (original-pages 368-369, subhead: “*Symptoms varying...*”), we considered what symptoms were likely to arise from defects at the various  $M^1L$  levels; and it was suggested that the symptoms most characteristic of schizophrenia were likely to have their origin from  $M^1L$  malfunctions. However it was also noted that loss of the ability to think abstractly and logically was<397> taken as a significant extra symptom suggesting a schizophrenic state, and that this defect was to be considered as a malfunction at the  $M^2L$  or “Formal Operations” level. If both types of symptom are both indicative of schizophrenia in some measure, and if they are traceable to inadequate mathematical-set-organizations within *different structures*, then this raises questions about what relationship, if any, there is between these structures.

Broadly speaking, we might expect the relationship between  $M^1L$  and  $M^2L$  defects to be either: (A) one in which some structural influence outside the two respective structures themselves comes to adversely affect them both in comparable degrees. (For instance, if we accept that the  $M^2L$  and  $M^1L$  structures both use the same material substrate — on some sort of recursive-like basis, as suggested in Section C5.4 and its Table — then the common cause could well be some defect within this common substrate). Or alternatively (B), a defect at one of these levels might be instrumental in precipitating, maintaining, or exacerbating a similar defect in the other. In fact there is no obvious reason to rule out the possibility of both types of causality occurring — either in different patients for each type, or even both within the same patient. [So the controversy over “organic” versus “psychogenic” aetiologies (Chapman and Chapman, pages 147-148) could perhaps be a contest over a non-issue — some schizophrenics suffering from (say)<398> generally-acting toxic effects within the substrate, some from the direct-or-indirect effects of misleading experience acting psychologically (see below), and some suffering from both.]

In the case of the psychogenetic causes, it has already been hinted here and in Section C8.1 that if the  $M^2L$  level has become defective to a socially-obvious extent, then it is probably some defect at the  $M^1L$  which is to blame — and not the reverse. After all, if the  $M^2L$  structures take as basic elements the schemata established by  $M^1L$  closure (as is supposed by the current theory),

then any breakdown at the  $M^1L$  level will tend to erode the schemata on which the  $M^2L$  level depends — either by directly disrupting these schemata, or more probably by simply failing to maintain and develop them properly. So if these various suggestions are correct, then such serious loss of abstract thought should either be thought of as a *secondary consequence* of more fundamental  $M^1L$  difficulties, *or else* as indicating some malfunction of the substrate common to both levels — or as a sign that the two different pathologies are occurring together.

There is also the likelihood of (C) a more involved *interactive* relationship between  $M^1L$  and  $M^2L$ . Consider, for instance, the orthodox view of abstraction (Chapman and Chapman, page 144) as the ability to single out “a common property from a range of stimuli” on each of a number of objects. What mechanisms is this skill likely<399> to entail? It rather looks as though the individual needs to be able to manipulate sets of various types of schemata, to represent objects, their properties (here *reified* as if they were objects ) and also actions connecting object-like things with object-like topologies. If such a task is to be feasible, one might reasonably suppose it essential to be able to organize these disparate entities in set-structures which stood higher in the  $M^1L$  hierarchy, than any of the entities directly involved. As the highest of the entities listed was what we would class as belonging at about the  $M^1L$  level, it would therefore seem to follow that any organizing set-structure would need to be at the  $M^2L$  level or higher. If this should happen to be true, it would go some way to reconciling the above “orthodox” view of the nature of abstraction, with the formal entailment of the  $M^2L$  level proposed here. But it also gives some indication of the possible interactive relationships which might exist between  $M^1L$  levels.

The possible choice of two or more different aetiologies for  $M^2L$  defects (perhaps also augmented by a volition-defect, which we will discuss next below, and maybe yet other causes) might shed some light on the diverse assortment of deviant behaviour which Goldstein<sup>84</sup> considered to exemplify *his* concept of “concreteness”,<400> and hence indicative of schizophrenia. Thus Chapman and Chapman (page 148) write: “Goldstein’s attempt to unite these diverse behaviours under a single principle tantalizes the reader with the hope that, if only he can penetrate Goldstein’s true meaning, he will obtain insight into the essence of schizophrenic thinking.” Whether the present account gets anywhere near this “true meaning”, or an acceptable substitute for it, is a matter for current debate. Anyhow, the comment continues: “...Despite his emphasis on loss of conscious volition [see below] as the [unifying] core phenomenon of the concrete attitude, Goldstein described concreteness in such diverse ways that clinicians with widely differing views can all find it congenial. Almost any conceivable error can be interpreted as concrete.”

The comment then goes on to point out that Goldstein denied the appropriateness of “intercorrelations between measures of the various kinds of concreteness”. Insofar as the different types of symptom do have independent causes, on the lines suggested above, then this criticism of intercorrelational studies would seem to be well-founded; and as it is suggested at the finish of this work, there is often a tendency to expect too much in the blind use of such techniques. However it is probably overstating the case to claim that such tests could tell us nothing useful: the above arguments imply possibilities of *some* inter-correlation; and even a null<401> result would be quite informative, implying a need for independent therapeutic treatments.

#### (4) *Loss of Volition or Conscious Control.*

It will be recalled that, in Sections C6.3 and C6.4, a previous attempt was made to postulate what the formal structural organization of “consciousness” might be. Unfortunately, though not

<sup>84</sup> Goldstein (1939, 1944/1964, 1959); Goldstein and Scheerer (1941, 1953); Goldstein and Salzman (1967).<400>

altogether surprisingly, the resulting suggestions were not particularly convincing in view of the sparseness of detail proposed,<sup>85</sup> so that it is difficult to test or corroborate the ideas with any precision, even if we are content just using *internal closure* criteria (see Chapter C1) — never mind any external experimental criteria of the more conventional type! However, for whatever value it might have in the present discussion, we may recall that it was supposed that two necessary conditions for consciousness were *attention* and *self-concept*, and that concepts such as *sentience* might conceivably be explicable in these terms.

*Attention* is discussed at the beginning of Section C6.3 (and in the third paragraph of Section C5.5)<sup>86</sup> in terms of a metaphorical fitting of a limited number of privileged schemata into “a room” or “control centre”. The implication is clearly that some sort of extensively-defined set is crucially involved, that this set and its<402> members have a temporary privileged access to the individual’s ongoing activity, and that there is some comparatively rigid limit to the number of direct members that can be admitted within the “attention span”<sup>87</sup> at any one time (G A Miller, 1956a, 1956b; Pascual-Leone, 1970). So, whatever the details of the physical mechanism which presumably underlies attention, it seems likely that it may be subject to broadly the same sort of defect as the  $M^1L$  and  $M^2L$  mathematical-sets which we have been considering above — though not necessarily at the same time, nor necessarily at the same physical sites, nor necessarily for the same aetiological reasons.

*Self-Concept* is considered above in paragraphs 6 to 8 of Section C6.3,<sup>88</sup> where it is suggested that the most central aspects of it are probably at the  $M^1L$  level, though there is also a case for placing them within the  $M^0L$  level — or perhaps some unique amalgam of both. Whatever the details, one’s self-concept or *ego* or *personal identity* is likely to be a much more involved construct than the schemata for ordinary external objects; but it still seems plausible, as far as we can see at this stage, that this complicated self-concept will nevertheless consist ultimately of a basic extensive-set schematic structure of physical molecular elements —<403> essentially similar to that postulated for other extensive sets.

Putting these two supposed components of consciousness back together, we might reasonably expect that the total phenomenon will still be describable, at least in principle, in terms of the various mathematical-set structures which we have been discussing. Of course there is also the further complication that an exhaustive model would have to account, not only for consciousness itself, but also for the way in which it *controls* ongoing activity: more-or-less correctly in normal individuals, or inadequately in individuals behaving according to the Goldstein formulation of Schizophrenia *as* a loss of conscious volitional control. However there is no obvious reason why the additional feature of a control-link should make the basic postulate of molecular set-structure untenable, though the complications implicit in this problem are formidable:-

Thus we may recall the topological dilemma concerning where consciousness should belong in the  $M^pL$  hierarchy; (Sec C3.2/paragr 7, and Sec C6.4/paragr 4).<sup>89</sup> Although no fully detailed account of likely mechanisms emerged from these deliberations, they did at least produce a logical solution to the immediate dilemma by placing consciousness, as such, in a category of its own — standing aside from the linear hierarchy of the  $M^pL$  scale. It thus seemed to occupy a potentially privileged position<404> of relatively easy control-access to schemata of all levels, on

<sup>85</sup> It is hoped that future theoretical investigation will remedy this deficiency.<402>

<sup>86</sup> Original pp.224-225 (see margin): “[...]”, which also invokes Section A1.4.

<sup>87</sup> One might profitably enquire whether each  $M^pL$  level might have its own private attention-span, and explore complications raised by this.<403>

<sup>88</sup> Orig.pp.246-247: “The second point ... Piagetian description.”

<sup>89</sup> Respectively: Orig.p.172 “As for consciousness...” — and O.p.265 “Section...”

average; though to the extent that there exists a body of subconscious and unconscious thoughts, it will be obvious that this privilege is certainly not total. Anyhow, to mark this supposedly exceptional status, it was suggested that consciousness be considered as being in an exceptionally-named level: the  $M^{top}L$  level.

So what then should we make of Goldstein's notion that "loss of conscious volition" is, or should be, the defining principle for identifying schizophrenia. From a strictly practical point of view, this is most unhelpful "because its presence or absence is almost impossible to judge" (Chapman and Chapman, page 149). And even as a theoretical basis there is precious little, at this stage, that one could do in the way of structural development if one were committed to this definitional dependence on "consciousness" as the fundamental construct. Not that the existence of such potential inconveniences necessarily means that Goldstein is wrong; though we might well pray that he is, because if he is right then there will be a great deal of theory for us to clarify in considerable detail before we are likely to have a reasonably accurate insight into the nature of schizophrenia. Nevertheless it is hoped that we do not reject his ideas merely because of wishful thinking in this direction!

But even if he *is* right, it still seems likely that any deeper, more-micro, level of explanation will involve<405> disturbance of one or more of the brain's postulated extensive-definition set structures; and it remains possible that whichever of these structures happen to be faulty in any given type of schizophrenia the faults will all fall within a reasonably circumscribed range of types of structural error afflicting essentially similar mechanisms, (at the molecular level, or whatever).

Finally it is perhaps worth considering that if Goldstein does happen to be wrong on this point, and loss of volitional control is merely a secondary symptom, then its logical status is likely to be much the same as that postulated for logical and abstract thinking in the immediately preceding discussion: item "(3)". In this case, the comments made there concerning causal chains from  $M^1L$  deficiencies to  $M^2L$  symptoms, are likely to apply comparably to causal chains from  $M^1L$  to " $M^{top}L$ " — or wherever we finally decide that consciousness should properly be located in the functional topology.

#### (5) *A Negativistic Attitude, or Paranoid Tendencies.*

It has already been argued in Section C7.7, that paranoia is primarily a *neurosis* rather than a psychosis, but that its nature is such as to encourage a certain amount of disorganization within some of the mathematical-set structure acquired by the brain, thus tending to produce some psychotic symptoms. (This question of *causes* of set-deterioration will be discussed below in its own right). But, as with many syndromes of this general type, it is quite on the cards that there was actually a small<406> amount of unwarranted and socially disadvantageous set-disorganization in the first place — along with a small amount of neurosis — and that the two tended to exacerbate each other in a positive feedback situation, so that the collective behavioural syndrome eventually escalated until it became socially evident. In such a situation, it is not a clearcut issue to attribute causality; in fact it constitutes an example of the "chicken and egg" dilemma. And even if the neurosis was indeed the root cause initially, it is likely that it would have passed unnoticed in many cases if there were no supporting feedback loop operating subsequently via psychotic disruption. In other words, it may not always be possible or desirable to make a complete logical distinction between the two types of disorder.

Accordingly it is perhaps sensible to include this *negativistic* syndrome under both headings: neurosis *and* psychosis. At any rate, it does often appear in the psychosis-category; and its symptoms are offered as correlating with a diagnosis of schizophrenia. Indeed this seems to be the main characteristic of the patients discussed by Laing (1960/1965, 1961/1971), as pointed out earlier in Sections C6.3 and C7.7. Thus if social "objects" such as public institutions come to be

seen as malevolent, then the individual will tend to reject such “objects” in the apparent-cause of bolstering his own self-identity schema. Such withdrawal of cathexis will sometimes take on an aggressive form such as diminished-cooperation, like<407> Kraepelin’s (1919) patient who persistently answered numerical questions with answers which all seemed to be deliberately wrong — a phenomenon described by Bleuler as “intellectual negativism”, (Chapman and Chapman, “evasion” page 9). Work propounding this viewpoint of the basic nature of schizophrenia includes Sullivan (1924, 1925, 1944/1964) where the patients are seen as having lost the motivation to communicate, and Haley (1959) where the concept of “motivated retreat” is used — as in Laing (1960, 1961); Chapman and Chapman, pages 228-230)

408

### C8.3 Some Comments on the Accepted Dimensions for Classifying schizophrenias and Related Conditions

Elsasser has suggested that the crucial difference between physics and biology lies in the fact that physics deals with mainly-homogeneous systems, while in biology it is inevitable that the systems be very markedly “inhomogeneous”. This inhomogeneity has been traced down to molecular level by experimental procedures for some aspects of biological function, such as genetic inheritance, though not in others such as memory — at least not in adequate experimental detail. Nevertheless it has been a principal objective of the present work to offer credible suggestions as to how memory *could* be accounted for at the molecular level, in terms of a very considerable degree of inhomogeneity — though not to the extent of leaving it in complete chaos.<408>

409

But as all too often occurs in practice, there is a price to be paid for progress. To the extent that our model of the brain becomes more inhomogeneous in its basic micro-structure, the more we should come to suspect the validity of those modelling techniques which we have come to value for homogeneous systems such as “the perfect gas”, or the civil engineer’s “three-dimensional space”. After all, even the real gases encountered by the physicist are not really “perfect” and under some conditions they produce “behaviour” which is not at all in accordance with Boyle’s law — thus leading to seemingly arbitrary artefactual models such as the cubic equations of van der Waals. In fact it is not until we enquire deeply into the basic structural nature of gases that we can make reasonable progress towards removing the appearance of arbitrariness which the (modified) cubic equation presents. In a similar spirit, we might well be wary therefore, of blindly transferring the mathematical assumptions of simple-paradigm behavioural psychology down into the realm of the molecular elements which are, according to the present theory, the basis of inhomogeneity underlying psychological phenomena.

In particular it may be doubted whether psychological systems can really be adequately and meaningfully expressed by “dimensions” in a Cartesian-coordinate system. It would appear that this assumption is commonly made, and moreover made quite unconsciously (as if the successful use of this conceptualization in applied physics were sufficient guarantee of its universal applicability!) This belief<409> in the applicability of Cartesian coordinates underlies many of the experimenter’s statistical tools, such as multiple-factor analysis, so the question is of some general relevance. Indeed the results of such procedures are unquestionably often technologically useful — just as Boyle’s law is often technologically useful. There may even be some discoverable structural basis for the constructs inferred and named on the basis of such analyses (Cattell, 1965), though the technique itself will not be much help in elucidating what that structural basis might be. However, one might perhaps feel that the method assumes away many of the interesting problems, so that any findings which do eventuate will merely have scratched the surface — leaving the “real workings of government” well hidden.

410

The sort of structural effects which are likely to conspire against this approach include: internal feedback and delay, internal interaction between elements or parts of the system, and



effects arising from the fact that the system is actually made up of heterogeneous discrete elements rather than a continuum. Now the interesting thing is that there is a good chance that, in principle, one could by-pass these difficulties by using a finer “level of resolution” into a large number of subsystems, to such an extent that *none* of the complications just listed are *internal* any more. In other words, one can hope for a reductionistic Utopia in which each individual *subsystem* is free from complications like<410> internal feedback, and whatever feedback there is will be *between* such subsystems. Experimentally though, this will probably not be much help if these subunits are too small, too delicate, and too numerous to be measured sufficiently; and even if we can infer the basic structure by other means, we may then still have huge problems in turning such information into a usable model — though we might, if we are lucky, find a special trick of the trade such as “Statistical Mechanics”.

411

Having said all that, let us re-examine some of the “dimensions” offered in the literature as being indicative of schizophrenia. And, more to the point, let us try to see past the orthodox behaviouristically-oriented formulation and comment on the likely structural basis for the dimensions in question.

### Process/Reactive

The *Process-Reactive Distinction* is discussed in Chapman and Chapman as probably constituting more than “merely two end-points on a continuum of premorbid adjustment” (page 334). The *Reactive* type is likened to Kraepelin’s manic depressive (page 28) and is seen as having a good chance of recovery, while the *Process* type of patient is likened to Kraepelin’s dementia praecox as a “typical” schizophrenic with: “inadequate prepsychotic adjustment, with little interest in other people or the activities of life ... develops gradually ... with no identifiable precipitating stress. ... usually ... affective flattening, ... prognosis is poor, ... deteriorating course”.<411>

412

Without attempting any very detailed analysis of these distinctions, some preliminary observations on the basis of the current theory might assist us to orient ourselves to the issues likely to be involved. One impression about these latter symptoms is that they seem more likely to have their origins deep within the personality structure of the individual, with significant components from experiences in early life, or in inherited biases within the mathematical-sets’ substrate, or both. Another impression is the likely importance of experiences involving affective relationships, or the genetically-determined nature of whatever structures serve to “encode” affective relationships (whether these be “tag”-involving procedures as has been suggested here, or some different arrangement).

As a tentative working hypothesis therefore, it might be useful to think of Process Schizophrenia as stemming from the individual’s failure to acquire *stable* object-like *socially-oriented* structures, at-or-about the Sensori-motor stage ( $M^0L$ ); — or as having acquired them without the “appropriate” affective affiliations (which might also have a direct or indirect bearing on their ultimate stability). We might then wish to distinguish between ▪ those cases which arose genetically, ▪ those generated through damaging experiences (of different sorts, perhaps), and ▪ those with various admixtures of these two influences. Behaviourally speaking though, there might be little difference between such categories.

413

By contrast, we might suppose that Reactive Schizophrenics suffer from<412> comparable disruptions at some higher  $M^N L$  level, probably the Concrete Operations ( $M^1L$ ) level, which would have presumably developed later and be more amenable to readjustment — as well as being less far-reaching in their consequences. whether or not genetic components are likely to make much contribution toward Reactive Schizophrenia would seem to depend on whether the relevant parts of the two respective  $M^N L$  levels operate within substrates which are both subject to the same genetic influences. Thus if both levels are likely to suffer the same genetic

disruption, then presumably the Process-symptoms will pre-empt any would-be development of Reactive symptoms; so anyone diagnosed as simply Reactive would presumably be free from any such *generally-acting* genetic defects — except perhaps in an auxiliary role. But of course, if each **M<sup>n</sup>L** level operated within a substrate which was genetically independent in origin (with respect to mechanisms relevant to our present discussion), then we might well expect to find occasional genetic components in any pre-disposition to Reactive Schizophrenia or manic-depressive personality, (and without them also promoting Process Schizophrenia at the same time).

### *Hebephrenic/Paranoid*

The *Hebephrenic-Paranoid Distinction* is implicit in the comparative properties discussed above in Section C8.2, in the two items “(1) and (5)” respectively, or indeed in the special *supposedly neurotic* affiliations of the<413> latter “paranoid” item *vis a vis* any of the other four; — and this developed a theme introduced earlier in Section C7.7.

414

Chapman and Chapman make some interesting comments concerning this supposed-dimension:

“Although the distinction between paranoid and nonparanoid patients accounts for some of the heterogeneity of performance among schizophrenics, the distinction is not clearly one of different disorders. As Kraepelin himself pointed out, few patients fit unambiguously into one subtype, and even those who do *may shift from one symptom picture to another* ... A patient may, for example, initially show predominantly paranoid symptoms, and later show predominantly hebephrenic or catatonic symptoms. Such changes indicate that these symptoms represent different stages of the same disorder rather than distinct disorders. Not all patients, however, shift symptom patterns”. (Page 30, emphasis added).

Such a dynamic evolution is clearly within the spirit of the above-mentioned danger of progression from a neurotic beginning into more-psychotic states. Whether these successive stages are to be regarded as representing “the same” disorder or not is perhaps a little beside the point and a matter of mere semantics; the crucial issue is to decide what the essential cybernetic dynamics are likely to be, and not to try to clothe such phenomena in a terminology which implies static configurations.<414>

“Progress on this problem is hindered both by the dearth of theory to guide the research and by the failure of research workers to use objective and reliable criteria for diagnosis of the paranoid subtype.” (Chapman and Chapman, pages 333-4). The current theory might perhaps help to fill this breach, or to inspire other theories which do; but of course that remains to be seen.

415

### *Acute/Chronic*

The *Acute-Chronic Distinction* is discussed by Chapman and Chapman (pages 321-331). Changes in symptom patterns over time are hardly surprising if the brain is viewed as a dynamic and more-or-less self-organizing system, as we have just seen in the preceding comments about paranoia. In such a system it is likely that an abnormal operation of set-structures at one **M<sup>n</sup>L** level, or even just an isolated part of such a level, will sometimes disturb the consolidation or maintenance of set-structures elsewhere — bringing the possibility that there will be *eventual* profound changes in the overall system. (A useful rough analogy is offered by consideration of the long-term economic consequences of a substantial increase in the price of oil!) In some cases the progression may be propagated through largely internal processes, such as those postulated for the paranoid’s decline into hebephrenia; in others the change may be largely brought about by external influences such as hospitalization or other institutionalization influences. But from a strictly cybernetic viewpoint, it is not necessarily important to distinguish between such *internal* and *external* mediators of<415> the exacerbating feedback loops; rather we should ask which loops can be broken through our “autonomous” intervention. Thus we might, because of socio-political reasons, be powerless to change the “external” influences of hospitalization, and yet we

416

might conceivably be able to stop the progression by medication — though whether this should be called “internal” or not is a moot point, and it constitutes another semantic issue.

Such chronicity should, of course, be taken into account; and it has considerable practical implications. But it looks as though it should properly be regarded as merely secondary as far as symptom-analysis is concerned, and not a particularly informative basis from which to try to derive a useful fundamental “dimension”. Of course if we were to get beyond a mere consideration of “time served” and look more deeply into the apparent changes of state in the various subsystems within the total system, then this would be real progress (and probably Utopian progress at that!); but it is questionable whether such information could be conveniently fitted onto one linear dimension, or perhaps even onto *any* Cartesian coordinate space.

Two other separate criteria, arising out of Goldstein’s overly inclusive category of “concreteness”, have been proposed as dimension-like dichotomies<sup>90</sup> by McGaughran (1954),<sup><416></sup> and McGaughran and Moran (1956, 1957) — as outlined by Chapman and Chapman (pages 156-8).

417

### *Public/Private*

Of these, the *Public-Private Distinction* might plausibly be attributed to the *acceptance* of the conceptual categories used conventionally within their culture, in the case of non-paranoid subjects, or *rejection* of such conceptualizations in the case of paranoids — either as an aggressive gesture against society in retaliation for its supposed malevolence, or for some arbitrary reason which has resulted in the past in a “malevolent” response from society, thus engendering the feeling of persecution lead to the paranoid state. Anyhow the findings of McGaughran and Moran (1957) and of Silverman and Silverman (1962) found a correlation of “privateness” of response with “paranoid-schizophrenia” diagnosis which tends to support this view of their common origin.

### *Open/Closed*

The other dimension-or-dichotomy arising from these studies is the *Open-Closed distinction* which refers to the use of *open-ended* categorizations versus *closed* unique “categories” which tend to constitute trivial one-member sets. The latter one-member tendency turns out to be associated with brain-damaged patients rather than schizophrenics — those whose sortings under a test were of the type that Goldstein described as ‘stimulus-bound’, or as an excessive response to the ‘immediate experience of the given thing or situation in its particular uniqueness.’” From this, and from the typical responses given, there is some basis for believing that these effects in brain-<sup><417></sup>damaged patients are symptoms of an underlying defect in which some of the ability to place objects into conceptual mathematical-sets has been erased completely; so that the individual makes do with individual items instead of the sets which might have contained them, and even for these single items he is dependent on the support of perceptual input due to the presumed shortage of adequate set-structures to constitute the normal attention-span.

418

By contrast, those particular types of schizophrenic which were used in these studies did seem to be able to apply concepts like “redness” to the objects which were presented to them, and therefore presumably they were able to form. mentally the mathematical-sets entailed in this type of classification. It is less clear whether or not these subjects had other well-defined set-forming aberrations, such as difficulty with  $M^2L$  control of such activities or whether their performance with solid objects is matched by a similar competence with “social objects”. It might perhaps be worth investigating the possibility that in the brain-damaged patients, there is a more uniform

419

<sup>90</sup> Despite McGaughran’s suggestion that these should be seen as continua, it is arguable that this view is only applicable to experimental measures, and not to underlying phenomena; or even if they do represent some statistical reality, there is nevertheless a discrete basis to them at the micro level.<sup><416></sup>

disruption across all types of mathematical-set activity at all levels, while those with experience-based schizophrenias have defects centring on that particular aspect of set-organization which is most related to the schizogenic experience. Or else, looking at the question more generally, perhaps all we should postulate is that there will be a *different distribution* of set-handling deficiencies, without attempting to specify<418> in advance just what the respective distributions should be; though from our present structure-oriented point of view this rather amounts to admitting temporary defeat! But of course our “intelligent guesses” at structure depend on there being some important and coherent rationale as a historical background to existing mechanisms — and arbitrary brain damage is unlikely to have much relevant rationale behind it!

419

### Attention focus

*The Narrowed-versus-Broadened Attention Distinction* — and related effects such as over-inclusion and distractability. The literature on this type of symptom is reviewed in Chapman and Chapman (Chapter 13, pp 253-285 ), and some of the theoretical issues have already been touched on in the present work (Section C5.5, para 3; Section C8.2, paras 13 and 34).<sup>91</sup> However our present aim is not so much to encompass the whole field as to test the potential explanatory power of the current structural theory in isolated typical cases, and in particular in those situations where existing explanations have the most difficulty in accounting for the facts (even if, in the end, their explanations do seem to be correct). Accordingly we shall confine our attention here to the comparative studies and interpretations offered by Broen (1966) which are discussed in Chapman and Chapman (pages 278-280). ;

Let us look first at Broen’s concept of “*response disorganization*” and re-interpret it in terms of the<419> current structural theory. Consider that the individual will generally need to discriminate between “*dominant*” responses (which are, in some sense, to be considered as appropriate) and “*competing*” responses — represented presumably by schemes or schemata which are physically available, but are *not* appropriate in the above sense. When stated in this way, it becomes easy to identify Broen’s *dominant responses* with member-schemoids listed in an appropriate set-structure and thus having “extensive definition”. This then would seem to be the relevant organization, and its absence would then be the “response disorganization” envisaged by Broen. The practical result of this deficiency would indeed be expected to be “that the frequency of the various response alternatives become more nearly equal for schizophrenics than for normal subjects”.

420

In the present work, we have often come across the idea that there are likely to be many categories of set-structure: notably between  $M^0L$  levels, but also probably for various different areas of activity (presumably also corresponding to different physical areas within the brain, though not necessarily distinguishable in macroscopic anatomical terms). Anyhow it would appear that Broen makes at least some distinction of this sort by singling out “*focusing responses*” for special consideration as what amounts to the operation of a particular set-structure designated for *attention-holding* purposes. <420> By way of contrast, the interpretation which follows below will envisage at least *two* relevant organizations for attention — corresponding to  $M^1L$  and  $M^2L$  thought processes respectively.

421

Given certain circumstances which we will come back to shortly, the patient’s attention is said to become “narrowed” — thus “reducing the range of stimuli they observe” down to those with the strongest “pull” or saliency. A promising structural interpretation of this progression is as follows:- The patient’s ability to comprehend *objects in extensive sets* is diminishing, due to some breakdown in set-organization in the relevant part of the  $M^0L$ - $M^1L$  interface, leaving the

<sup>91</sup> Section C5.5, para 3: o.p.223- “[...]” — Section C8.2(2) para 4: o.p.386-387 “Looking next...” — and Section C8.2(4) para 2: o.p.402-403 “Attention is...”

patient to do the best he can with the primitive techniques of *intensive-definition* calling of schemata. Consequently we might well expect that the actual object-schemata which actually reach attention will be those “shouting the loudest”, so to speak — which probably means either that their elemental molecular representatives are in a majority in some sense, or that sense-impressions from them have some sort of monopoly over the sensory-input channels. Accordingly the patient will tend to fixate on these “salient” items, having lost the ability to give a balanced consideration to the full range available to him in the real external world; or to put it in Piagetian terminology, his attention will no longer be “decentré”. moreover, when the patient does shift his attention to some other item such a move is likely to<421> follow syncretic associations rather than “logical categories” .

422

In other sets of circumstances, also outlined below, there is a loss of the patient’s apparent ability to guide himself to the use of “appropriate” criteria when sorting objects. Instead he will seemingly be content to make indiscriminate use of *any* attribute which he happens to light upon as being common to some of the objects, including such features as “shadows or scratches” which normal subjects automatically assume to be irrelevant. (This assumption of irrelevance *could* have a social-norm or formal-logic component; but it is perhaps more likely that it reflects a basic **M<sup>0</sup>L** awareness of the mathematical-group properties of *objects* as such, and therefore a feel for what is not-real-object but mere sensual artefact like shadows and perspective — accessory details which the **M<sup>1</sup>L**-stage artist will sensibly ignore until perhaps he acquires the **M<sup>2</sup>L** sophistication which enables him to rationalize their inclusion again for particular purposes).

Anyhow it would seem that, although the patient is apparently able to form mental extensive-sets of objects (as long as other pathologies are absent), he is *not* keeping proper extensive sets for some other feature of the task. This other feature could be the *properties* of objects including their **mathematical**-group-like nature, suggesting that the patient’s mental encoding of objects must be<422> tending to become mere empty ciphers devoid of genuine object-like characterization; — the name or form only, without the substance. Alternatively the phenomenon could be due to the loss of some set-structure which would normally provide guide-lines as to which would-be characteristics of objects are worthy of attention. On the face of it, this seems less likely — except insofar as *social* conventions may be a component in the choice of “appropriate” features.

423

We may now try to apply these formulations to the first of the two dilemmas which Broen considered, but concentrating on the non-paranoid patients for whom the relevant effect was greatest (as we might expect on the theoretical grounds outlined earlier). The dilemma lay in the apparently contradictory findings of Payne (1962) and Chapman (1961), because while Payne found more “overinclusion” amongst his *acute* patients, Chapman found more of *his version* of “overinclusion” in his *chronic* patients. (Broen himself suggests a solution to this dilemma using a somewhat different conceptual approach. It can plausibly be argued that his explanation is formally compatible in its essentials with the one given below; but that is an issue which we will not pursue here in any depth).

Payne’s concept of “overinclusion” amounted to his subjects using the very “shadows or scratches” which we have just been discussing. Such a “response disorganization”, arguably in the form of a loss of appreciation of<423> the “objectness” of objects, is in keeping with the sort of defect that one might expect from a non-paranoid schizophrenic — if the current theory is on the right track. There is, however, no obvious reason why such symptoms (and their underlying mechanisms) should diminish over time as originally-“acute” patients turn into “chronic” patients”. On the other hand though, it is quite plausible that this condition’s underlying mechanisms might remain more-or-less constant and yet the manifest effects arising from them might disappear somewhat with chronicity due to the masking action of some other development.

424

That, in fact, is the essential point made in Broen's explanation, and he identities the new development as the "narrowed observation" with which we began about four paragraphs ago.

By contrast, Chapman's (1961) version of "overinclusion" involved the gratuitous addition of items which were approximately correct by virtue of some sort of association. Such errors can reasonably be identified as syncretic thought, lacking the set-structure guidance of reliable extensive-definition of object sets, and so indicative of one form of mental decline. Not only that, but it is not difficult to imagine that such a deficiency could pre-empt the manifestation of Paynes's type of overinclusion — though the argument is scarcely clearcut enough to actually make reliable *predictions* of this sort. (That, of course, is unfortunate; and it is to be hoped that future developments will remedy this situation).<424>

The second dilemma investigated by Broen (1966) was the apparent disparity between the findings of Venables (1964) and Chapman (1956). According to Venables, chronic schizophrenics attend to a range of stimuli which is narrower than normal; and of course that is very much what we might expect from the theory of schizophrenia adopted in the present work, and the discussion of six paragraphs back in particular. However Chapman (1956) had found that the same general category of patient (chronic schizophrenics) were more distractable than normal subjects, and this seemed to imply that they therefore had a wider span of attention than the normal. In retrospect this might perhaps be seen as a semantic dispute over the term "wideness of span":- Does it mean the wideness of a narrowly-focussed but highly-rotatable searchlight beam? Or does it mean the wideness of a parachute-flare? Anyhow Broen offered what seems to be a very credible explanation along these lines, attributing the different experimental implications to the centripetal and centrifugal effects of the more salient items in the two respective cases; and such an explanation would appear to be entirely compatible with structural accounts of syncretic thought (in default of extensive set-structure) as expounded here.

### *In closing*

Some closing comments about the strengths and weaknesses of such explanatory exercises are, perhaps, called for at this stage. Attention is (apparently) a phenomenon of some considerable complexity; and the<425> current theory, with its emphasis on potentially-detailed substructure, is likely to have a lot to say about complex phenomena. Indeed the trouble is that it is likely to have too many possible explanations to offer, and the difficulty will then be in deciding which ones, if any, are likely to be correct — and in what combinations, and under what circumstances. In other words, we have a situation in which the stock criticism "It explains everything but predicts nothing" might be partly justified. Nevertheless we should perhaps be content *for the moment* to have a theory which *does* tend to "explain everything" — that is, one which offers too many plausible structurally-based solutions rather than none at all. However, to the extent that it is true that such explanations "predict nothing", this would be a clear indication that further work and elaboration is called for to fill in structural, qualitative and quantitative details of the theory and its implications.

### **C8.4 Aetiological Issues: By what mechanisms are Psychoses likely to Originate?**

It is clear that there are at least two different categories of cause for schizophrenia: "Anybody who at this stage of our knowledge takes a wholly genetic or wholly environmental view of aetiology is clearly in error" (Venables, 1975); so obviously any theoretical approach to the problem must be compatible with both. Moreover it seems likely that there are also different sub-categories within each of these two areas: different<426> parts of the presumed structural organization which are affected differently by *different genetic* factors, and also various qualitative types of initial disruption to set-organization which are likely to arise from *different experiential* anomalies. Any truly detailed explication of these causal chains will probably have

425

426

427

to await a detailed exposition of the underlying mechanisms, be they molecular or whatever. But meanwhile, we have now developed the present theory sufficiently for us to be able to indicate the likely broad outline of the processes leading to psychoses in general, and those relatively enduring psychotic states which we include under the term “schizophrenia” in particular. The experience-based aetiologies seem to be the most difficult of these to conceptualize, so we shall leave them till last; but the others can now be outlined quite briefly, given the conceptual framework which has been elaborated in the present work so far. Let us start with the schizomimetic effects as discussed in Chapman and Chapman (Chapter 15):-

### *Drugs.*

For any theory which postulates that crucial activities are being carried on at the molecular level, it is patently obvious that drugs are likely to produce specific disruptions to particular parts of the proposed mechanism. Offhand, for instance LSD and Mescaline might both stop the efficient activity of at least some of the extensive-set mechanisms — though arguably there would be a differential impact on different categories of such mechanism. Then maybe Sernyl somehow interferes with the <427> proper operation of the supposed “tag” effects, leading to feelings of unreality or depersonalization. Likewise perhaps Amphetamine has an impeding effect on the schemata related to the ego, thus promoting a predisposition toward paranoid feelings. (These illustrations are offered merely as impressionistic examples, and should not be taken too seriously as they stand). Anyhow, given the present conceptual framework and a measure of good fortune, systematic investigations along these lines could conceivably be highly rewarding.

428

### *Brain Damage.*

The present work has been primarily concerned with an ultra-micro view of the brain’s supposed activities, but clearly there are also meaningful things to be said about the same system when viewed in grosser terms (just as there is value in viewing aspects of economic phenomena both at the level of the individual *and* at the level of the firm — or industry, or nation). However our more macro pronouncements are likely to make better sense if we have a proper understanding, of the micro-phenomena, which are the basis of the macro-phenomena; — and having made better sense of the macro data we will then be in a better position to use it to shed further light on the micro-phenomena. In other words, there is room for profitable mutual cooperation between these two viewpoints. <428>

429

Thus the concepts involving intensive and extensive set-defining mechanisms postulated here, offer some new dimensions to the interpretation of the significance of brain lesions and any tendency there may be for the patient to recover from them; while of course brain-lesion data is very useful in clarifying some of the “geographical” mathematical-set-tendencies within the brain, and also its behavioural consequences provide useful benchmarks against which schizophrenic behaviour patterns can be usefully compared. If, for instance, we can identify the behaviour patterns of brain-damaged patients in terms of set-structure failure (and this seems likely), then it is likely to be an informative exercise to account for different distributions of the *types* of such failure in the two cases — with a reasonable chance of thereby shedding some light on the way the brain system is organized, and what aspects are most vulnerable to the different types of disruption.

### *Sleep Deprivation.*

Section C6.6 of the present work suggests that sleep may constitute special consolidation-periods in which set-structures are vetted for their “internal closure”, and that the coherence or “sanity” of surviving mental configurations is therefore likely to depend on this sleep activity. Accordingly we should not be surprised if sleep deprivation produces symptoms which resemble

the more permanent ones of schizophrenia. Moreover we can reasonably go further and suggest that a<429> selective deprivation of orthodox sleep (if that were possible) would selectively impoverish the  $M^0L$  level initially, while selective deprivation of REM sleep will preferentially upset the  $M^1L$  coherence. As an interesting further speculation we might consider whether *meditation* or “time to collect one’s thoughts” might serve the same sort of function for the  $M^2L$  level of logical thought; so perhaps such “high pressure” treatment as *Speeded Performance* could be expected to produce psychomimetic symptoms in the form of a trend toward non-logical Primary Process thinking. Flavell *et al.*’s (1958) findings might conceivably be interpreted in these terms, though of course it is unwise to make too much of such an analysis *post hoc* — and one should rather design new experiments specifically based on the new conceptualizations. (Chapman and Chapman, page 317).

### Sensory Deprivation.

It has been part of the general philosophy of the present work that the development and maintenance of useful set-structures within the brain (like useful concepts in science) depend on two complementary processes. These are the testing of *internal* consistency (as just discussed in connection with sleep), and secondly the testing of the *external* consistency of one’s mental structures *vis a vis* reality, by means of a more-or-less continual interaction between these domains. Clearly any prolonged sensory deprivation will interfere with this latter process and therefore, according to our<430> theory, some progressive deterioration of some aspects of mental organization are likely. (This indeed may be taken as a special case of a more general biological principle that organization tends to depend on the relevant structure actually being used. For example, an unused limb will tend to atrophy or develop inappropriately — apparently because its development and maintenance actually depend on the cues given by the stresses of life interacting with the system). Anyhow, suffice it here to say that such schizomimetic symptoms arising as a consequence of sensory deprivation would seem to be very much compatible with the current theory.

### Incidental Minor

Other schizomimetic-inducers could be interpreted as acting through some aspect of the brain’s overall set-structural organization *other than* the actual set-structure in question. In other words, it looks as though the self-stabilizing activities of this focal schema are specifically disrupted by the interfering “exogenous” action of some other schema within the total system. It will suffice for our present purposes if we merely identify the conditions which might plausibly be operating in this way, and also suggest the likely route of their presumed intervention.

- *Relaxed Attention* is produced by conscious intent, so we may presume that it is the complex ego-schema which deliberately lets certain set-supporting activities lapse, temporarily.
- In *Distraction* there is a (voluntary *or* involuntary) overload on the attention, thus disrupting<431> its proper function; and the source will presumably be the intrusion of irrelevant stimuli and their internal coding — unless perhaps we choose to blame the ego-schema again, for the “voluntary” situations.
- *Hypnosis*, insofar as we understand it at all, does seem to be exactly such an intervention — instigated and controlled by that other special schema representing supposedly-social demands: the superego.
- *Operant Training* may be devised by the experimenter to produce deviant responses; and this presumably operates through normal “ordinary” set-structures — and probably via essentially commonplace mutations to the focal set-structure itself, or to some other such structure normally instrumental in maintaining it.



### *Perception manipulation*

*Disruption of Perception* such as Aaronson's (1967) use of posthypnotic suggestion to induce the subject to believe that the normal "unquestionable" laws of nature had ceased to operate. Such a situation (which did in fact produce psychotic symptoms) would presumably have been seen by the subject as unwelcome evidence that he was losing his control over happenings in the external world. It thus turns out to be (subjectively and temporarily) a case of a general experiential arrangement which *does* lead to schizophrenia, and which rather looks like being the main-or-only experiential cause of schizophrenia. We shall come to this issue almost immediately, and conclude this section on that note; but first let us<432> deal with the question of inheritable pre-dispositions toward schizophrenia:-

433

### *Genetic Factors promoting Schizophrenia.*

When an engineer sets out to design an aircraft or a bridge, he will have to assume the competing demands of maximal strength versus minimal weight-or-cost — and probably other troublesome variables as well, like pollution-rate, resonance-frequency range and specificity, wind-resistance characteristics, and so on. If the final project is to be viable, taking the total existing conditions into account, then the "dimensional space" into which the design must fit will be comparatively small — and probably very much more restricted than the naive commentator might expect. Similarly, if the body is to avoid undue risk of infection and yet not have such an active immunological system that it destroys its own useful structures, then there will be a definite limitation to the range of acceptable "designs" for such a system; (though in practice here, the "design" will be by the rather uncomfortable process of natural selection).

It is not necessary to know all the details (about how molecular-based set-structures might operate) for us to realize that such a system is bound to have many aspects where the details of adjustment have to be "pre-designed" in much the same way. Thus it will be no good to the individual if his set structures are so stable that no new evidence can make any impression on these structures (nor *find* an appropriate mutant version); but on the<433> other hand the individual will also come to grief if his set-structures are so adaptable that no encoding of experience-based discoveries can be relied on to retain its information unchanged. The compromise required here is presumably between over-creativity and ultra-conservatism, but the basic principle of finding the proper balance between conflicting demands appears to be the same. Moreover, in the absence of "genetic engineering", the acceptable range will have to be found and maintained by the same unfair survival-of-the-fittest principle as that applying to immunological systems — though perhaps we are now talking about the survival of "mental health" rather than life itself. However the settings of these values will only "set the stage"; and actual "mental survival" will also depend on experiential factors:-

434

### *Schizogenic Environmental Conditions.*

It will be helpful to start by comparing some of the likely properties of ordinary mental schemata with those of the special ego schema. For one thing, the ramifications of the ego will almost certainly be much more far-reaching than those of any other schema; and this presumably amounts to saying that the ego-structure will be very much "bigger", in terms of membership and internal-closure-loops, than any other mental schema. Thus, if the individual has managed to assemble any recognizable ego-set at all, then the mutual corroboration amongst the closure loops of this complex set-structure will probably make it substantially more *stable* than any other mental schema. So on primarily structural grounds we have some reason to<434> believe that the ego-schema has a privileged stability status, and that is likely to mean that responses to its attempted disruption will appear to be qualitatively different from similar attempts on the integrity of other existing schemata.

435

If we look at the same issue from a functional viewpoint, it seems reasonable to regard the ego-structure as the *sine qua non* of a humanoid being's mental organization. In other words, like the King in chess, its integrity is equated with that of the system as a whole and cannot be regarded as negotiable, whatever the price. (Not that the brain would have been assembled according to any consciously argued "design", but presumably nature has had to keep trying until the appropriate arbitrary mutants present themselves for selection). So, on these grounds too, we might expect the ego to be especially protected from any serious threat to its essential integrity, even though other ordinary set-structures might come to be radically altered or superseded.

In this context, it is interesting to consider Masserman's (1971) view that psychoses (and other mental dysfunctions) arise from particular types of uncertainty concerning the environment — and the individual's own ability to cope with it:- "Doubts and trepidations about our capacities to predict and cope with impending and important events induce the internal physiological signals we interpret as 'anxiety', and variably actuate<435> the symbolically evasive (phobic), hopefully repetitive (compulsive ritualistic), regressive-dependent (depressive), reactively overassertive (paranoid), dysaffective and dereistic (schizoid), and other individualized attempts at mastery or denial which, depending on the extent and duration of their deviation from current cultural norms, are then labelled 'ideosyncratic', 'neurotic', 'sociopathic', or 'psychotic'".

436

Moreover we can get a clearer insight into the type of uncertainty which is involved here. The account given by Kimmel (1971a) traces the laboratory evidence on this effect to Yerofeeva (1916), and especially to Shenger-Krestovnikova (1921) whose experiment, with dogs, entailed a learned discrimination between circles and ellipses. Uncertainty was introduced in the latter case, by progressively using ellipses which were more-and-more circle-like — thus presumably eroding the dogs' confidence that they could really cope with a discrimination which they thought they had mastered. Anyhow the result was: "a neurotic-like breakdown without the use of any aversive stimulation whatever". One might perhaps quibble as to whether this might actually be classed as an aversive stimulus, though obviously it is not what one normally understands the term to mean; but we may recall that the current theory takes it that the accomplishment of internal closure should be regarded as rewarding-in-itself and accompanied by subjective feelings of satisfaction, so presumably a loss<436> of internal-closure will be unpleasant. Anyhow we can see that the two conceptualizations seem to be compatible, and the merely semantic difficulty should cause us no real problem.

437

If we can agree that the dog *does* feel this situation as casting uncertainty into its felt-ability to cope — as an attack on its ego-schema in other words — then according to the principles of privileged-protection for the ego put forward above, the dog will go to almost any extreme to try to redeem the situation. One interesting point is that the resulting breakdown was described as "neurotic-like" rather than psychotic. Perhaps we should not read too much into the distinction, but suppose we do take it at face-value; *Why* is it a neurotic response rather than a psychotic one? And what has happened to our explanation for schizophrenia?

One clue to the latter question is the course supposedly taken by some cases of paranoia (see Section C8.3 paragraph 10, and other references mentioned there)[1st para on o.p.415!! Next perhaps?]. There we had a condition with an arguable status as an initial neurosis, but with inbuilt tendencies to progress into psychosis. One interesting possibility is that whereas "paranoia", as usually categorized, entails a more-or-less *conscious* mistrust of *social* objects and processes; perhaps some other types of neurosis could be described as a less conscious, lower **M<sup>n</sup>L** level, mistrust of rather more-basic aspects of the environment. Such neuroses might<437> perhaps then run a similar risk of progressing into psychosis, though, if they were low **M<sup>n</sup>L** types, they might tend toward more hebephrenic or "Process" categories of schizophrenia.

438

As for “why ... neurotic?”, there is no obvious clearcut answer (if indeed the claim is well founded). Suppose however we were to postulate a wider category of paranoid-like neuroses on the lines just suggested, and envisaged them as all resulting from various different sorts of dangerously-close attacks on the ego; then from a structural point of view we might expect to find some rather desperate attempts to save the closure of the ego-structure by “amputating” that part of it which seemed to have become contaminated, and re-closing the remainder of the ego-elements into a somewhat diminished ego-structure. (This, of course is substantially what Laing suggests (1960); but the main difference is that we are here considering a basically similar process for a wider range of basic structures associated with the ego-structure, and not just the more social-object phenomena of traditional paranoids).

There is though, something appealing about the supposed origin in an attack on the ego-structure. That, after all, is what neurotic defense-mechanisms are supposed to be intimately involved in. Moreover, it could be this very feature which makes for the greater stability and duration in schizophrenia proper — as opposed to mere schizomimetic psychoses which perhaps always result from <438> attacks on schemata *other than* the ego itself.

### C8.5 Which Direction For Future Research?

439

We started in Section C1.1 by contemplating Chapman and Chapman’s (1973) ideas concerning future research into schizophrenia; and it was suggested that a mere tightening up of statistical design (on operationalist/behaviourist lines) as proposed by them, was not likely to produce greatly improved insight. Since then, some quite complex structures have been postulated here, on theoretical grounds, to account for schizophrenia and associated phenomena; so it is now pertinent to ask whether Chapman and Chapman’s proposed conventional and objective approach could ever have led to such complex conceptualizations, unaided by the “less respectable” techniques such as those used here.

Note that even if the theory offered here should turn out to be totally wrong, it would nevertheless have served to show that the underlying mechanism *could* plausibly be very much *more complex* (though orderly) than most psychological or computer-models would have us believe; so that doubt must remain concerning the practical usefulness of Chapman and Chapman’s proposal for future research.

It should be recognized that there are important uses for theories which spell out structural details of the supposed micro-structure, and that one of these uses is *to guide the experimenter* to those correlations-or-whatever which it might be most profitable to investigate. If the <439> lead should turn out to have been a false one, then at worst one has simply just done *yet another* experiment which has not done much to further our insight; but in practice it is likely that we can achieve some worthwhile modification of the structural theory which will enable us to try again.

440

In fact, in general, we may expect a useful interplay between the two approaches at many stages of an investigation: from initial considerations to concluding interpretations. Indeed, according to the epistemological arguments outlined in Section C1.1, there is little basis for adopting either experimental-investigation, nor internal-closure-seeking as *the* superior approach; rather we should consider the two as complementary. So let us, by all means, press on with suitable experimental studies; but we would do well to press on with structural theoretical developments also — and use these two approaches in a mutually guiding and supporting collaboration. <440>

## REFERENCES

- Concerning multiple-dates in the form “(a/c)” or “(a/b/c)”:-  
 The a = date of the original publication in the original language;  
 c = date of the version principally referred to; while b = date of first edition in English  
 (subject to occasional complications due to different publication dates in different countries).
- Aaronson, B. S. (1967). “Hypnosis, responsibility, and the boundaries of self”. *Amer. J. Clinical Hypnosis*, **9**, 229-246.
- Abbot, B. C., A. V. Hill, and J. V. Howarth. (1958). “The positive and negative heat production associated with a nerve impulse”. *Proc. Roy. Soc., B*, **148**, 149-187.
- Abelson, R. P. (1959/1967). “Modes of resolution of belief dilemmas”. In M. Fishbein (ed.) (1967); Chapter 38, pages 349-356.
- Abelson, R. P., and M. J. Rosenberg. (1958/1967). “Symbolic Psychologic: a model of attitudinal cognition”. In M. Fishbein (ed.) (1967); Chapter 37, pages 341-348.
- Agrawal, M. C., Y. K. Singh, and S. C. Gupta. (1977). “Variation in the surface-charge density of an excitable nerve membrane exposed to optical radiation”. *IEEE Transactions on Electromagnetic Computability*, **EMC-19**(1), 29-33.
- Ansell, G. B., and P. B. Bradley, eds. (1973). *Macromolecules and Behaviour*. Macmillan: London.
- Ashby, W. R. (1956/1964). *An Introduction to Cybernetics*. Methuen: London.
- Ashby, W. R. (1960: Second Edition). *Design for a Brain*. Chapman & Hall: London.
- Ayer, A. J. (1978). “On the cleansing of the metaphysical stables”. *The Listener*, **99**(2549), 268-270. [Originally broadcast under the title “Logical Positivism and its Legacy”, BBC-2].
- Baldwin, A.L. (1967). *Theories of Child Development*. Wiley: New York and London.
- Bannister, D (1968). “The myth of physiological psychology”. *Bull. Brit. Psychol. Soc.*, **21**, 229-231.
- Barlow, H.B., R.Fitzhugh, and S.W.Kuffler. (1957). *J. Physiol.*, **137**, 338-354.
- Barron, D.W. (1968). *Recursive Techniques in Programming*. MacDonald: London. Elsevier: New York.
- Bartlett, F.C. (1932). *Remembering: a study in experimental and social psychology*. Cambridge University Press.
- Beck, L.H., and W.R.Miles. (1947). “Some theoretical and experimental relationships between infrared absorption and olfaction”. *Science*, **106**, 511.
- Beckner, M.O. (1967). “Mechanism in Biology”. In P.Edwards (ed.) (1967) *Encycl. Phil.*, **5**, 250-252.
- Beer, S. (1972). *Brain and the Firm: the managerial cybernetics of organization*. Penguin: Harmondsworth, Middlesex.
- Bell, A.E. (1947). *Christian Huygens and the Development of Science in the Seventeenth Century*. Edward Arnold: London.
- Benade, A.H. (1960). *Horns, Strings and Harmony*. Anchor: Garden City, NY.
- Berscheid, E., and E.H.Walster. (1969). *Interpersonal Attraction*. Addison-Wesley.
- Bhaumik, D., K.Bhaumik, and B.Dutta-Roy (1976a). “On the possibility of ‘Bose condensation’ in the excitation of coherent modes in biological systems”. *Phys. Lett.*, **56A**(2), 145-148.
- Bhaumik, D., K.Bhaumik, and B.Dutta-Roy (1976b). “A microscopic approach to the Fröhlich model of Bose condensation of phonons in biological systems”. *Phys. Lett.*, **59A**(1), 77-80.
- Bishop, G.H. (1956). “Natural history of the nerve impulse”. *Physiol. Rev.*, **36**, 376-399.
- Bitterman, M.E. (1970). “Visual probability learning in the rat”. *Psychonomic Science*, **22**, 191-192.
- Bleuler, E. (1911/1950) . *Dementia Praecox or the Group of Schizophrenias*. International Universities Press: New York.
- Blum, M. (1962). “Properties of a neuron with many inputs”. In *Principles of Self-organization*, H. von Foerster and G.W. Zopf, eds., pp 95-120; Pergamon Press: Oxford.
- Bolles, M.M. (1937). “The Basis of Pertinence”. *Archives of Psychology*, (212), 1-51. [Monograph].
- Boyd, I.A. and M.R.Davy (1968). *Composition of Peripheral Nerves*. E & S Livingstone Ltd.: Edinburgh and London.

- Boyd, I.A. and K.U.Kalu. (1973). "The relation between axon size and number of lamellae in the myelin sheath for afferent fibres in groups I, II, and III in the cat". *J. Physiol., London*, **232**, 31P-33P.
- Bridgman, P.W. (1927). *The Logic of Modern Physics*. Macmillan: New York.
- Broen, W.E., jr. (1966). "Response disorganization and breadth of observation in schizophrenia". *Psychol. Rev.*, **73**, 579-585.
- Brown, J.S. (1961). *The Motivation of Behaviour*. McGraw-Hill: New York.
- Bruner, J.S. (1974). *Beyond the Information Given: Studies in the psychology of knowing*. George Allen & Unwin: London.
- Bruner, J.S., and B.M.Bruner. (1968). "On voluntary action and its hierarchical structure". *Intern. J. Psychol.*, **3**, 239-255. [Republished in Bruner (1974)].
- Bruner, J.S., J.J.Goodnow, and G.A.Austin. (1956/1967). *A Study of Thinking*. Wiley: London and New York.
- Bunge, M. (1962). *Intuition and Science*. Prentice-Hall: Eaglewood Cliffs, NJ.
- Bunge, M. (1973). *Philosophy of Physics*. D.Reidel Publishing Company: Dordrecht, Holland.
- Bureš, J., and O.Burešová (1970). "Plasticity in single neurones and neuronal populations". In Horn and Hinde (1970), 363-403.
- Burnett, G.M., A.M.North, and J.N.Sherwood, eds. (1974). *Transfer and Storage of Energy by Molecules: Vol. 4. The Solid State*. Wiley: London and New York.
- Carnap, R. (1928/1967). *The Logical Structure of the World [and Pseudoproblems in Philosophy]*. Routledge & Kegan Paul: London.
- Cattell, R.B. (1965/1967). *The Scientific Analysis of Personality*. Penguin: Harmondsworth, Middlesex
- Chamberlain, J.W., G.W.Chantry, H.A.Gebbie, N.W.B.Stone, T.B.Taylor, and G.Wyllie. (1966). "Submillimetre absorption and dispersion of liquid water". *Nature, London*, **210**, 790-791.
- Chapanis, N.P., and A.Chapanis. (1964). "Cognitive dissonance: five years later". *Psychological Bulletin*, **61**, 1-22.
- Chapman, L.J. (1956). "Distractibility in the conceptual performance of schizophrenics". *J. Abn. Soc. Psychol.*, **53**, 286-291.
- Chapman, L.J. (1961). "A reinterpretation of some pathological disturbances in conceptual breadth". *J. Abn. Soc. Psychol.*, **62**, 514-519.
- Chapman, L.J., A.G.Burstein, D.Day, and P.Verdone. (1961). "Regression and disorders of thought". *J. Abn. Soc. Psychol.*, **63**, 540-545.
- Chapman, L.J., and J.P.Chapman. (1973). *Disordered Thought in Schizophrenia*. Appleton-Century-Crofts: New York.
- Chung, S., S.A.Raymond, and J.Y.Lettvin. (1970). "Multiple meaning in single visual units". *Brain Behav. Evol.*, **3**, 72-101.
- Cohen, M.H., and A.Robertson (1971a). "Wave propagation in the early stages of aggregation of cellular slime molds". *J. Theor. Biol.*, **31**(1), 101-118.
- Cohen, M.H., and A.Robertson (1971b). "Chemotaxis and the early stages of aggregation in cellular slime molds". *J. Theor. Biol.*, **31**(1), 119-130.
- Coombs, J.S., D.R.Curtis, and J.C.Eccles. (1957). "The generation of impulses in motoneurons". *J. Physiol., London*, **139**, 232-249.
- Cope, F.W. (1973). "Electron-phonon (trapped photon) coupling and infrared coaxial transmission line theory of energy transport in mitochondria and nerve". *Bull. Math. Biol.*, **35**, 627-644.
- Copleston, F. (1960/1961). *A History of Philosophy*. Burns & Oates: London.
- Coppin, C.M.L., and J.J.B.Jack. (1972). "Internodal length and conduction velocity of cat muscle afferent nerve fibres". *J. Physiol., London*, **222**, 91P-93P.
- Craik, K. J. W. (1952). *The Nature of Explanation*. Cambridge University Press.
- Crew, H., ed. (1900). *The Wave Theory of Light: Memoirs by Huygens. Young and Fresnel*. American Book Company: New York.
- Crowther, J.G., and R.Whiddington. (1947). *Science at War*. HMSO: London.
- Darwin, C. (1859). *On the Origin of Species by Natural Selection, or the preservation of favoured races in the struggle for life*. John Murray: London.
- Diamond, I.T., and W.C.Hall. (1969). "Evolution of neocortex". *Science*, **164**, 251-262.

- Dixon, N.F. (1976). *On the Psychology of Military Incompetence*. Jonathan Cape: London.
- Dutton, J.M., and W.H.Starbuck. (1971). "Computer simulation models of human behaviour: a history of an intellectual technology". *IEEE Transactions on Systems, Man and Cybernetics*, **SMC-1**(2), 128-171.
- Eccles, J. C. (1964). *The Physiology of Synapses*. Springer: Berlin.
- Eccles, J. C. (1970). *Facing Reality: Philosophical adventures by a brain scientist*. London.
- Edwards, P., ed. (1967). *The Encyclopedia of Philosophy*. Macmillan, and Freepress: New York and London.
- Ellis, B. (1966). *Basic Concepts of Measurement*. Cambridge University Press.
- Elsasser, W.M. (1958). *The Physical Foundation of Biology*. Pergamon Press: Oxford.
- Elsasser, W.M. (1961). "Quanta and the concept of organismic law". *J. Theor. Biol.*, **1**, 27-58.
- Elsasser, W.M. (1966/1971). *Atom and Organism: A new approach to theoretical biology*. Princeton University Press: Princeton, NJ.
- English, H.B., and A.C.English. (1958). *A Comprehensive Dictionary of Psychological and Psychoanalytical Terms*. Longmans: London.
- Erikson, E. H. (1950/1973). *Childhood and Society*. Penguin: Harmondsworth, Middlesex.
- Evans, C.R., and A.D.J.Robertson, eds. (1968). *Key Papers: Cybernetics*. Butterworths: London.
- Eysenck, H. J. (1965). *Fact and Fiction in Psychology*. Penguin: Harmondsworth, Middlesex.
- Fenichel, O. (1946/1971). *The Psychoanalytic Theory of Neurosis*. Routledge & Kegan Paul: London.
- Ferenczi, S. (1926). "The psyche as an inhibiting organ"; in (his) *Further Contributions to the Theory and Technique of Psychoanalysis*. Institute of Psychoanalysis, and Hogarth Press: London.
- Finean, J.B. (1967). *Engström-Finean Biological Ultrastructure*. Academic Press: New York.
- Fishbein, M., ed. (1967). *Readings in Attitude Theory and Measurement*. Wiley: London and New York.
- Flavell, J.H., J.Draguns, L.D.Feinberg, and W.A.Budin. (1958). "A microgenetic approach to word association". *J. Abn. Soc. Psychol.*, **57**, 1-7.
- Franks, F., ed. (1972-1973). *Water: A comprehensive treatise* (4 vols.). Plenum Press: New York and London.
- Fraser, A., and A.H.Frey. (1968). "Electromagnetic emission at micron wavelengths from active nerves". *Biophys. J.*, **8**, 731-734.
- Freud, S. (1900/1964). *The Interpretation of Dreams* [volumes 4 and 5 of *The Standard Edition of the Complete Psychological Works of Sigmund Freud*. The Hogarth Press and the Institute of Psychoanalysis: London]
- Freud, S. (1914/1925/1957). "On narcissism: an introduction". In *Collected Papers of Sigmund Freud*, **IV**. Hogarth Press and Institute of Psychoanalysis: London. Pages 33-59.
- Freud, S. (1915/1925/1957). "Instincts and their vicissitudes". In *Collected Papers of Sigmund Freud*, **IV**. Hogarth Press and Institute of Psychoanalysis: London. Pages 60-33.
- Freud, S. (1917/1920). *Introductory Lectures on Psychoanalysis*. Boni & Liveright: New York.
- Freud, S. (1922). *Beyond the Pleasure Principle*. International Psychoanalytical Press: London.
- Freud, S. (1924a/1933). "Neurosis and psychosis". In *Collected Papers of Sigmund Freud*, **II**. Hogarth Press and Institute of Psychoanalysis: London. Pages 250-254.
- Freud, S. (1924b). "The loss of reality in neurosis and psychosis". In *Collected Papers of Sigmund Freud*, **II**. Hogarth Press and Institute of Psychoanalysis: London. Pages 277-282.
- Freud, S. (1927a). *The Ego and the Id*. Institute of Psychoanalysis, and Hogarth Press: London.
- Freud, S. (1927b). "Fetishism". In *The Complete Works of Sigmund Freud*. Hogarth Press and Institute of Psychoanalysis. Vol. **21**; pp 152-157.
- Freud, S. (1936). *The Problem of Anxiety*. Norton: New York.
- Fröhlich, H. (1968). "Long-range coherence and energy storage in biological systems". *Intern. J. Quantum Chem.*, **2**, 641-649.
- Fröhlich, H. (1975). "Evidence for Bose condensation-like excitation of coherent modes in biological systems". *Phys. Lett.*, **51A**(1), 21-22.
- Furth, H.G. (1969). *Piaget and Knowledge*. Prentice-Hall: New Jersey.
- Galbraith, J.K. (1977). *The Age of Uncertainty*. BBC: London.
- Gambling, T.E. (1978). *Beyond the Conventions of Accounting*. Macmillan: London. (In press).

- Gambling, T.E., and R.R.Traill. (1977). *Accounting for morale: fact, whitewash or fantasy?*  
Paper at the Workshop on Accounting in a Changing Social and Political Environment.  
(European Institute for Advanced Studies in Management; Oxford, April 1977).
- Gantt, W.H. (1971). "Experimental basis for neurotic behaviour". In Kimmel (1971b); Chapter 3, pages 33-47.
- Gardner, J.M. (1975). "Influencing the political system and the media". Tenth annual conference of the Australian Psychological Society; (Symposium: "Community Psychology: Return of the Magician").
- Gasking, D.A.T. (1960). "Clusters". *Australasian J. Phil.*, **38**, 1-36.
- Geren, B.B. (1954). "The formation from Schwann cell surface of myelin in the peripheral nerves of chick embryos". *Experimental Cell Research*, **7**, 558-562.
- Gillespie, D.T. (1970/1973). *A Quantum Mechanics Primer*. Intertext Educational Publications: New York.
- Ginsburg, H. and S.Opper. (1969). *Piaget's Theory of Intellectual Development*. Prentice-Hall: Eaglewood Cliffs, NJ.
- Glassman, E., and J.E.Wilson. (1969). *Pulse labelling of RNA during a short learning experience*. Paper presented at the annual conference of the British Psychological Society, Edinburgh.
- Gödel, K. (1931/1967). "On formally undecidable propositions of 'Principia Mathematica' and related systems". In J. van Heijenoort (1967), *From Frege to Gödel: a source book in mathematical logic, 1879-1931*; Harvard University Press: Cambridge, Massachusetts. Pages 596-616 .
- Goel, N.S., R.D.Campbell, R.Gordon, R.Rosen, H.Martinez, and M.Yčas. (1970). "Self-sorting of isotropic cells". *J. Theor. Biol.*, **28**, 428-468.
- Goel, N.S., and A.G.Leith. (1970). "Self-sorting of anisotropic cells". *J. Theor. Biol.*, **28**, 469-482.
- Goldstein, K. (1939). "The significance of special mental tests for diagnosis and prognosis in schizophrenia". *Amer. J. Psychiatry*, **96**, 575-587.
- Goldstein, K. (1944/1964) . "Methodological approach to the study of schizophrenic thought disorders". In J.S.Kasanin (ed.)(1964), *Language and Thought in Schizophrenia*. W.W.Norton: New York. Pages 17-40.
- Goldstein, K. (1959). "Concerning the concreteness in schizophrenia". *J. Abn. Soc. Psychol.*, **59**, 146-148.
- Goldstein, K., and M.Scheerer (1941). "Abstract and concrete behavior: an experimental study with special tests". *Psychological Monographs*, **53**(2, whole 239). {sic!}
- Goldstein, K., and M.Scheerer (1953). "Tests of abstract and concrete behavior". In A.Weider (ed.)(1953); *Contributions Toward Medical Psychology, II*. Ronald Press: New York. Pages 702-730.
- Goldstein, R.H., and L.F.Salzman. (1967). "Cognitive functioning in acute and remitted psychiatric patients". *Psychological Reports*, **21**, 24-26 .
- Goldstein, S.S., and W.Rall. (1974). "Changes of action potential shape and velocity for changing core conductor geometry". *Biophys. J.*, **14**, 731-757.
- Green, R.T., and V.J.Laxon. (1970). "The conservation of number, mother, water and a fried egg chez l'enfant".  
*Acta Psychologica*, **32**, 1-30.
- Griesinger, W. (1845/1861). *Pathologie und Therapie der psychischen Krankheiten*. Stuttgart.  
[Also published in English: (1867). *Mental Pathology and Therapeutics*. New Sydenham Society].
- Griffith, J.S. (1970). "The transition from Short- to Long-Term Memory".  
In Horn and Hinde (1970), pages 499-516.
- Grossman, Y., M.E.Spira, and I.Parnas. (1973). "Differential flow of information into branches of a single axon". *Brain Research*, **64**, 379-386.
- Haley, J. (1959). "An interactional description of schizophrenia". *Psychiatry*, **22**, 321-332.
- Hamilton, M. (1973). "Psychology in society: Ends or end?". (Presidential address). *Bull. Brit. Psychol. Soc.*, **26**(92), 185-189.
- Harrington, R.F. (1961). *Time-Harmonic Electromagnetic Fields*. McGraw-Hill: New York and London.

- Heaviside, O. (1893, 1899, 1912). *Electromagnetic Theory* (3 vols.).  
“The Electrician” Printing & Publishing Co. Ltd.: London.
- Hebb, D.O. (1949/1964). *The Organization of Behaviour*. Wiley: New York and London.
- Hess, A., and J.Z.Young. (1949). “Correlation of internodal length and fibre diameter in the central nervous system”. *Nature, London*, **164**(4168), 490-491.
- Hodgkin, A.L., and A.F.Huxley (1952a). “Currents carried by sodium and potassium ions through the membrane of the giant axon of *Loligo*”. *J. Physiol., London*, **116**, 449-472.
- Hodgkin, A.L., and A.F.Huxley (1952b). “The components of membrane conductance in the giant axon of *Loligo*”. *J. Physiol., London*, **116**, 473-496.
- Hodgkin, A.L., and A.F.Huxley (1952c). “A quantitative description of membrane current and its application to conduction and excitation in nerve”. *J. Physiol., London*, **117**, 500-544.
- Hodson, C., and L.Y.Wei. (1976). “Comparative evaluation of quantum theory of nerve excitation”. *Bull. Math. Biol.*, **38**(3), 277-293.
- Holland, B.W. (1972). “Dynamic specificity and the pairing of homologous chromosomes in meiosis”. *J. Theor. Biol.*, **35**, 395-397.
- Holloway, G.E.T. (1967). *An Introduction to the Child’s Conception of Space*.  
Routledge & Kegan Paul, and National Froebel Foundation: London.
- Horn, G., and R.A.Hinde, eds. (1970). *Short-Term Changes in Neural Activity and Behaviour*.  
Cambridge University Press.
- Horridge, G.A. (1962). “Learning leg position by the ventral nerve cord in headless insects”.  
*Proc. Roy. Soc., Series B*, **157**, 33-52.
- Horridge, G.A. (1968). *Interneurons*. Freeman: London and San Francisco.
- Hubel, D.H. (1963). “The visual cortex of the brain”. *Scientific American*, (Nov. 1963). [Republished in  
N. Chalmers et al. (1971), *The Biological Bases of Behaviour*; Harper & Row: London. Pages  
122-132].
- Hubel, D.H., and T.N.Wiesel (1959). “Receptive fields of single neurones in the cat’s striate cortex”.  
*J. Physiol.*, **148**, 574-591.
- Hubel, D.H., and T.N.Wiesel (1961). “Integrative action in the cat’s lateral geniculate body”.  
*J. Physiol., London*, **155**, 385-398.
- Hubel, D.H., and T.N.Wiesel (1962). “Receptive fields, binocular interaction and functional  
architecture in the cat’s visual center”. *J. Physiol., London*, **160**, 106-154.
- Hubel, D.H., and T.N.Wiesel (1963a). “Shape and arrangement of columns in cat’s striate cortex”.  
*J. Physiol., London*, **165**, 559-568B.
- Hubel, D.H., and T.N.Wiesel (1963b). “Receptive fields of cells in striate cortex of very young,  
visually inexperienced kittens”. *J. Neurophysiol.*, **26**, 994-1002.
- Hubel, D.H., and T.N.Wiesel (1965). “Receptive fields and functional architecture in two nonstriate  
visual areas (18 and 19) of the cat”. *J. Neurophysiol.*, **28**, 229-289.
- Hughes, M. (1965). “Neuronal pathways in the insect central nervous system”. In J.E.Traherne and  
J.W.L.Beament (eds.), *The Physiology of the Insect Central Nervous System*, Academic Press:  
London and New York.
- Hummel, D.O., K.Holland-Moritz, and E.Zoschke. (1972). “Spectra of aliphatic polyesters — some  
new results”. In P.Hepple (ed.), *Molecular Spectroscopy*; Institute of Petroleum: London. Pages  
297-308.
- Hunter, G. (1971). *Metalogic: An introduction to the metatheory of standard first order logic*.  
Macmillan: London and New York.
- Huxley, A.F., and Stämpfli. (1949). “Evidence for saltatory conduction in peripheral myelinated nerve  
fibres”. *J. Physiol., London*, **108**, 315-339.
- Hyland, M.E. (1977a). *Notes on the definition and use of hypothetical constructs*. Paper presented at  
the Exeter conference of the British Psychological Society, April 1977.
- Hyland, M.E. (1977b). *On the Nature and Use of Hypothetical Constructs: Rules for theory  
composition*. School of Behavioural and Social Sciences, Plymouth Polytechnic.
- Inhelder, B., and J.Piaget. (1959/1964). *The Early Growth of Logic in the Child: Classification and  
seriation*. Harper & Row: New York. Routledge & Kegan Paul: London



- Iversen, S.D. (1974). *Brain lesions and memory in animals*. Paper presented at the London conference of the British Psychological Society, December 1974.
- Jacob, F., and E.L.Wollman. (1961). "Viruses and genes". *Scientific American*, **204**, 92-107.
- Jahoda, M. (1972). *Social psychology and psycho-analysis: a mutual challenge*. Paper presented at the annual conference of the British Psychological Society, Nottingham, April 1972. [Main text published in *Bull. Brit Psychol. Soc.*, **25**, 269-274]
- Jenkins, F.A., and H.E.White. (1950). *Fundamentals of Optics*. McGraw-Hill: New York.
- Jouvet, M. (1967/1971). "The States of Sleep". *Scientific American*, February 1967. [Republished in N.Chalmers, R.Crawley, and S.P.R. Rose, eds (1971), *The Biological Bases of Behaviour*. Harper & Row: London and New York. Pages 199-210]
- Julesz, B. (1975). "Experiments in the visual perception of texture". *Scientific American*, **232**(4: April), 34-43.
- Jung, C. G. (1906/1936). "The psychology of dementia praecox". *Nervous and Mental Disease Monographs Series No 3*
- Kalu, K.U. (1973). *Conduction Velocity and Fibre Diameter in Myelinated Afferent Nerve Fibres of the Cat*, Ph.D. Thesis, Glasgow University.
- Karbowiak, A.E. (1965). *Trunk Waveguide Communication*. Chapman & Hall: London.
- Katz, B. (1966). *Nerve, muscle. and synapse*. McGraw-Hill: New York and London.
- Kaye, W. (1954). "Near-infrared spectroscopy: a review". *Spectrochim. Acta*, **6**, 257-287.
- Kelly, G.A. (1955). *The Psychology of Personal Constructs*. W. W. Norton: New York.
- Kilmer, W.L., W.S.McCulloch, and J.Blum. (1969). "A model of the vertebrate command system". *Intern. J. of Man-Machine Studies*, **1**(3), 270-310.
- Kim, J. (1967). "Explanation in science". In P. Edwards (ed.)(1967), *Encycl. Phil.*, **3**, 159-163.
- Kimble, D.P. (1969). "Possible inhibitory functions of the hippocampus". *Neuropsychologia*, **7**, 235-244.
- Kimmel, H.D. (1971a). "Introduction". In Kimmel (1971b), pages 1-10.
- Kimmel, H.D., ed. (1971b). *Experimental Psychopathology: Recent research and theory*. Academic Press; New York and London.
- Kinsler, L.E., and A.R.Frey. (1950/1962). *Fundamentals of Acoustics*. Wiley: New York.
- Kistenmacher, H., G.C.Lie, H.Popkie, and E.Clementi. (1974). "Study of the structure of molecular complexes. VI. Dimers and small clusters of water molecules in the Hartree-Fock approximation". *J. Chem. Phys.*, **61**, 546-561.
- Kleitman, N. (1963). *Sleep and Wakefulness*. University of Chicago Press.
- Koestler, A., ed. (1969). *Beyond Reductionism*. Hutchinson: London.
- Kollias, N., and W.R.Melander. (1976). "Laser-induced stimulation of chymotrypsin activity". *Phys. Lett.*, **57A**(1), 102-104.
- Krnjević, K. (1974). "Chemical nature of synaptic transmission in vertebrates". *Physiol. Reviews*, **54**(2), 418-540.
- Kuratowski, K. (1961). *Introduction to Set Theory and Topology*. Pergamon: Oxford.
- Laforgue, R. (1929). "The mechanisms of isolation in neurosis and their relation to schizophrenia". *Intern. J. of Psychoanalysis*, **10**, 170-182.
- Laing, R.D. (1960/1965). *The Divided Self*. Penguin: Harmondsworth, Middlesex.
- Laing, R.D. (1961/1971). *Self and Others*. Tavistock: London/Penguin: Harmondsworth, Middlesex.
- Landsberg, P.T., and D.A.Evans. (1970). "Free will in a mechanistic universe?" *Brit. J. Phil. Sci.*, **21**, 343-358.
- Lee, C-Y., and C. Chiang. (1976). "Nerve excitations by the coupling of the dipoles and the membrane matrix". *Bull. Math. Biol.*, **38**(1), 59-70.
- Leech, J.W., and D.J.Newman. (1959). *How to Use Groups*. Methuen: London.
- Leith, A.G., and N.S.Goel. (1971). "Simulation of movement of cells during self-sorting". *J. Theor. Biol.*, **33**, 171-188.
- Lettvin, J.R., H.R.Maturana, W.S.McCulloch, and W.H.Pitts. (1959). "What the frog's eye tells the frog's brain". *Proc. Inst. Radio Engineers*, **47**, 1940-1951.
- Lippold, O.C.J. (1970). "Long lasting changes in activity of cortical neurones" In Horn and Hinde (1970), pages 405-532

- Little, L.H. (1966). *Infrared Spectra of Adsorbed Species*. Academic Press: London and New York.
- Lindstrom, M. (1958). *Children's Art*. University of California Press.
- Livingston, R.B., K.Pfenninger, H.Moor, and K.Akert. (1973). "Specialized paranodal and interparanodal glial-axonal junctions in the peripheral and central nervous system: a freeze-etching study". *Brain Research*, **58**, 1-24.
- Lundström, I. (1974). "Mechanical wave propagation on nerve axons". *J. Theor. Biol.*, **45**, 487-499.
- McClare, C.W.F. (1971). "Chemical machines, Maxwell's Demon and living organisms". *J. Theor. Biol.*, **30**(1), 1-34.
- McCulloch, W.S. (1950/1968). "Machines that think and want". In Evans and Robertson (1968), pages 104-118.
- McCulloch, W.S., and W.H.Pitts. (1943). "A logical calculus of ideas immanent in nervous activity". *Bull. Math. Biophys.*, **5**, 115-133.
- McDougall, W. (1923/1931). *An Outline of Psychology*. Methuen: London.
- McGaughran, L.S. (1954). "Predicting language behavior from object sorting". *J. Abn. Soc. Psychol.*, **49**, 183-195.
- McGaughran, L.S., and L.J.Moran (1956). "'Conceptual level' vs. 'conceptual area' analysis of object-sorting behavior of schizophrenic and nonpsychiatric groups". *J. Abn. Soc. Psychol.*, **52**, 43-50.
- McGaughran, L.S., and L.J.Moran (1957). "Differences between schizophrenic and brain-damaged groups in conceptual aspects of object sorting". *J. Abn. Soc. Psychol.*, **54**, 44-49.
- Magat, M. (1948). "Sur la dispersion diélectrique de l'eau liquide". *J. de Chimie Physique*, **45**, 93-100.
- Malcolm, N (1967). "Wittgenstein, Ludwig J. J.". In P. Edwards (1967), *Encycl. Phil.*, **8**, 327-340.
- Mansfield, D.E., and M.Bruckheimer. (1965/1971). *Background to Set and Group Theory*. Chatto & Windus: London.
- Maratos, O. (1973) *The origin and development of imitation in the first six months of life*. Paper presented at the annual conference of the British Psychological Society, Liverpool, April 1973. [Abstract in *Bull. Br. Psychol. Soc.*, **26**, 157-158].
- Maratos, O. (1974). *Trends in the development of vocal imitation in the first six months of life*. Paper presented at the annual conference of the British Psychological Society, Bangor, April 1974. [Abstract in *Bull. Br. Psychol. Soc.*, **27**(95), 173]
- Maslow, A.H. (1954). *Motivation and Personality*. Harper & Row: New York.
- Masserman, J.H. (1971). "The principle of uncertainty in neurogenesis". In Kimmel (1971b), pages 13-32.
- Maturana, H.R., J.Y.Lettvin, W.S.McCulloch, and W.H.Pitts. (1959). "Anatomy and physiology of vision in the frog". *J. gen. Physiol.*, **43**(suppl.), 129-176.
- Maxwell, J.C. (1865). "A dynamical theory of the electromagnetic field". *Phil. Trans Roy Soc London*, **155**, 459-512.
- Mead, M. (1928/1954). *Coming of Age in Samoa*. Penguin: Harmondsworth, Middlesex.
- Mead, M. (1935/1950). *Sex and Temperament: in three primitive societies*. Wm. Morrow & Co.: New York.
- Mednick, S.A. (1964). *Learning*. Prentice-Hall: Eaglewood Cliffs, NJ.
- Miller, G.A. (1956a). "The magical number seven, plus-or-minus two: some limits on our capacity for processing information". *Psychol. Rev.*, **63**(2), 81-97.
- Miller, G.A. (1956b). "Information and memory". *Scientific American*, August 1956. [Republished in N.Chalmers, R.Crawley, and S.P.R. Rose (eds.)(1971), *The Biological Bases of Behaviour*; Harper & Rows London and New York. Pages 212-218].
- Miller, O. L., jr. (1973). "The visualization of genes in action". *Scientific American*, March 1973, 34-42, and 128.
- Miller, P.L. (1970). "Studies of learning in the insect central nervous system". In Horn and Hinde (1970), pages 475-498.
- Milner, B (1966). "Amnesia following operation on the temporal lobes". In C.W.M.Whitty, and O.L.Zangwill (eds.), *Amnesia*, Butterworth.
- Minkowski, H (1908/1923/1952). "Space and time". In H.A.Lorentz, A.Einstein, H.Minkowski, and H.Weyl, *The Principle of Relativity*, Dover: New York and London.

- Moens, P.B. (1973). "Mechanisms of chromosome synapsis at meiotic prophase". *Intern. Rev. Cytol.*, **35**, 117-134.
- Moncrieff, R.W. ( /1967). *The Chemical Senses*. Leonard Hill: London.
- Monod, J. , and F.Jacob (1961). "General conclusions: telenomic mechanisms in cellular metabolism, growth, and differentiation" *Cold Spring Harbor Symposia on Quantitative Biology*, **26**, 389-401.
- Nederveen, C.J. (1969). *Acoustical Aspects of Woodwind Instruments*. Fritz Knuf N.V.: Amsterdam.
- Nelson, J.O. (1967). "Moore, George Edward (1873-1958)". In P.Edwards (1967), *Encycl. Phil.*, **5**, 372-381.
- Norman, D.A. (1969). *Memory and Attention*. Wiley: London and New York.
- Norman, D.A., ed. (1970) . *Models of Human Memory*. Academic Press: New York.
- Oswald, I. (1964). "Physiology of sleep accompanying dreaming". In J.P.Ross (ed.), *Scientific Basis of Medicine: annual reviews*. Athlone Press: London.
- Oswald, I. (1966). *Sleep*. Penguin: Harmondsworth, Middlesex.
- Oswald, I. (1970). "Sleep the great restorer". *New Scientist*, **46**(698), 170-172.
- Pascual-Leone, J. (1970). "A mathematical model for the transition rule in Piaget's developmental stages". *Acta Psychologica*, **32**, 301-345.
- Passmore, J. (1967) . "Logical Positivism". In P. Edwards (1967), *Encycl. Phil.*, **5**, 52-57
- Pauling, L., and E.B.Wilson. (1935). *Introduction to Quantum Mechanics*. McGraw-Hill: New York.
- Payne, R.W. (1962). "An object classification test as a measure of overinclusive thinking in schizophrenic patients". *Brit. J. Soc. and Clin. Psychol.*, **1**, 213-221.
- Penfield, W. (1958/1967). *The Excitable Cortex in Conscious Man*. Liverpool University Press: Liverpool.
- Penfield, W., and L.Roberts. (1959). *Speech and Brain-mechanisms*. Princeton University Press: Princeton, NJ.
- Peterson, L.R., and M.J.Peterson. (1959). "Short-Term retention of individual verbal items". *J. Exp. Psychol.*, **58**, 193-198.
- Phillips, J.L., jr. (1969). *The Origins of Intellect: Piaget's Theory*. W.H.Freeman & Co.: San Francisco.
- Piaget, J. ( /1928/1951). *Judgement and Reasoning in the Child*. Kegan Paul, Trench, Trubner & Co. Ltd.: London. Harcourt, Brace & Co.: New York.
- Piaget, J. (1935/1953/1963). *The Origins of Intelligence in Children*. W.W.Norton: New York. Routledge & Kegan Paul: London.
- Piaget, J. (1941/1952/1969) . *The Child's Conception of Number*. Routledge & Kegan Paul: London.
- Piaget, J. (1945/1951/1962). [*La formation du symbole chez l'enfant*]: *Play, Dreams and Imitation in Childhood*. Routledge & Kegan Paul: London.
- Piaget, J. (1949). *Traité de logique*. Armand Collin: Paris.
- Piaget, J. (1952). "La logistique axiomatique ou 'pure', la logistique opératoire ou psychologique et les réalités auxquelles elles correspondent". *Methodos*, **4**(13), 72-85.
- Piaget, J. (1954/1968) . *The Construction of Reality in the Child*. Routledge & Kegan Paul: London
- Piaget, J. (1965/1972). *Insights and Illusions of Philosophy*. Routledge & Kegan Paul; London.
- Piaget, J. (1968/1971) *Structuralism*. Routledge & Kegan Paul: London.
- Piaget, J. (1972/1974). *The Child and Reality*. Frederick Muller: London.
- Piaget, J., and B.Inhelder (1948/1956/1963). *The Child's Conception of Space*. Routledge & Kegan Paul: London.
- Piaget, J., and B.Inhelder (1966/1971). *Mental Imagery in the Child*. Routledge & Kegan Paul: London.
- Piaget, J., and B.Inhelder (1969). "The gaps in empiricism". In Koestler (1969), pages 118-160.
- Pfaffman, C. (1951). "Taste and smell". In S.S.Stevens, (ed.), *Handbook of Experimental Psychology*. Wiley: New York. Pp 1143-1171.
- Pitcher, G. (1964). *The Philosophy of Wittgenstein*. Prentice-Hall: Eaglewood Cliffs, NJ.
- Popper, K.R. (1934/1959). *The Logic of Scientific Discovery*. Hutchinson & Co.: London.
- Popper, K.R. (1963/1969). *Conjectures and Refutations: the growth of scientific knowledge*. Routledge & Kegan Paul: London.
- Popper, K.R. (1972). *Objective Knowledge: An evolutionary approach*. Oxford University Press.

- Posner, M.I., and E.Rossman. (1965) "The effect of size and location of interpolated information reducing transformations upon short-term retention". *J. Exp. Psychol.*, **70**, 491-505.
- Pound, A. (1977). *The physiology and psychology of dreaming*. Paper presented at the annual conference of the British Psychological Society, Exeter, April 1977. [Abstract in *Bull. Brit. Psychol. Soc.*, **30**, 180].
- Prestige, M.C., and M.A.Wilson. (1974). "A quantitative study of the growth and development of the ventral root in normal and experimental conditions". *J. Embryol. and Exp. Morphol.*, **32**, 819-833.
- Pribram, K. H. (1971) . *Languages of the Brain: Experimental paradoxes and principles in neuropsychology*. Prentice-Hall: Eaglewood Cliffs.
- Pribram, K. H. (1972). "Cortical function in vision: serial and parallel processing mechanisms". *Proc. Ann. Conf. Brit. Psychol. Soc.*, Nottingham, (April 1972), page 20 (abstract only).
- Pribram, K.H., M.Nuwer, and R.J.Baron. (1974).  
 "The holographic hypothesis of memory structure in brain function and perception". In R.C.Atkinson, S.H.Krantz, R.C.Luce, and P.Suppes (eds.), *Contemporary Developments in Mathematical Psychology*. W.H.Freeman & Co.: San Francisco.
- Pysh, J.J., and R.G.Wiley. (1974). "Synaptic vesicle depletion and recovery in cat sympathetic ganglia electrically stimulated in vivo — evidence for transmitter secretion by exocytosis". *J. Cell Biol.*, **60**, 365-374.
- Radestock, P. (1879) . *Schlaf und Traum*. Leipzig.
- Ramo, S., J.R.Whinnery, and T. van Duzer. (1965). *Fields and Waves in communication electronics*. Wiley: New York.
- Ranck, J.B., jr. (1975). "Which elements are excited in electrical stimulation of mammalian central nervous system: A review". *Brain Research*, **98**(3), 417-440.
- Rasminsky, M., and T.A.Sears. (1972). "Internodal conduction in undissected demyelinated nerve fibres". *J. Physiol.*, **227**, 323-350.
- Ray, P. S. (1972). "Broadband complex refractive indices of ice and water". *Appl. Optics*, **11**(8), 1836-1844.
- Read, J. (1947). *Humour and Humanism in Chemistry*. G.Bell and Sons Ltd.: London.
- Rechstaffen, A., G.Vogel, and G.Shaikun. (1963). "Inter-relatedness of mental activity during sleep". *Arch. gen. Psychiat.*, **9**, 536-547.
- Rescher, N. (1973) . *The Coherence Theory of Truth*. Clarendon Press: Oxford. [Reviewed by L.S.Ford (1974), *Phil. and Phenomenological Research*, **35**(1), 118-120].
- Ressler, N. (1976). "Control of mitochondrial processes by the coupling of resonant energy to hydrogen-transfer reactions". *Perspectives in Biol. and Med.*, **19**(3), 388-401.
- Robertson, C.W., B.Curnutte, and D.Williams. (1973). "The infrared spectrum of water". *Molecular Physics*, **26**, 183-191.
- Robertson, J. D. (1960) . "Molecular structure and contact relationships of cell membranes". In J.A.V.Butler, and B.Katz (eds.), *Progress in Biophysics and Biophysical Chemistry*, **10**, 343-418. Pergamon Press: Oxford.
- Rodnick, E.H., and D.Shakow. (1940). "Set in the schizophrenic as measured by a composite reaction time index". *Amer. J. Psychiatry*, **97**, 214-225.
- Rushton, W.A.H. (1951). "A theory of the effects of fibre size in medullated nerve". *J. Physiol., London*, **115**, 101-122.
- Scherner, K.A. (1861). *Das Leben des Traumes*. Berlin.
- Scoville, W.B., and B.Milner. (1957). "Loss of recent memory after bilateral hippocampal lesions". *J. Neurol., Neurosurg., and Psychiatry*, **20**, 11-21.
- Shenger-Krestovnikova, N. R. (1921) . "Contributions to the question of differentiation of visual stimuli and the limits of differentiation by the visual analyser of the dog". *Bulletin of the Lesgaft Institute of Petrograd*, **3**, 1-43.
- Siegel, S., A.E.Siegel, and J.McM.Andrews. (1964). *Choice, Strategy and Utility*. McGraw-Hill: New York.
- Silverman, J. (1964a). "Scanning-control mechanism and 'cognitive filtering' in paranoid and nonparanoid schizophrenia". *J. Consulting Psychol.*, **28**, 385-393.

- Silverman, J. (1964b). "The problem of attention in research and theory in schizophrenia". *Psychol. Rev.*, **71**, 352-379.
- Silverman, L.H., and D.K.Silverman. (1962). "Ego impairment in schizophrenia as reflected in the object sorting test". *J. Abn. Soc. Psychol.*, **64**, 381-385.
- Skilling, H.H. (1948/1962). *Fundamentals of Electric Waves*. Wiley: London and New York.
- Slater, J.C. (1955). *Modern Physics*, McGraw-Hill: New York.
- Sloman, A. (1976). "What are the aims of science?". *Radical Philosophy*, **13**, 7-17.
- Smythies, J.R. (1969). "Aspects of consciousness". In Koestler (1969), pages 233-245.
- Spencer, P.S., C.S.Raine, and H.Wisniewski. (1973). "Axon diameter and myelin thickness — unusual relationships in dorsal root ganglia". *Anatomical Record*, **176**, 225-243.
- Spencer, W.A., and R.S.April. (1970). "Plastic properties of monosynaptic pathways in mammals". In Horn and Hinde (1970), pages 433-474.
- Sperry, R.W. (1953). "The effect of 180° rotation in the retinal field on visuomotor coordination". *J. exp Zool.*, **92**, 263-279.
- Stämpfli, R. (1954). "Saltatory conduction in nerve". *Physiol. Rev.*, **34**, 101-112.
- Stein, R.B. (1974). "Peripheral control of movement". *Physiol. Rev.*, **54**(1), 215-243.
- Stein, W.D. (1967). *The Movement of Molecules across Membranes*. Academic Press: New York and London.
- Steinberg, M.S. (1963). "Reconstruction of tissues by dissociated cells". *Science*, **141**, 401-408.
- Steiner, K-H. (1973). *Interactions between Electromagnetic Fields and Matter*. Pergamon Press: Oxford.
- Sterling, R.R. (1975). "Toward a science of accounting". *Financial Analysts Journal*, (Sep.-Oct. 1975), 42-53.
- Stumpf, H., ed./transl. (1973). See Steiner, K-H.
- Sullivan, H.S. (1924). "Schizophrenia: its conservative and malignant features". *Amer. J. Psychiatry*, **81**, 77-91.
- Sullivan, H.S. (1925). "Peculiarity of thought in schizophrenia". *Amer. J. Psychiatry*, **82**, 21-86.
- Sullivan, H.S. (1941/1964). "The language of schizophrenia". In J. S. Kasanin (1964). *Language and Thought in Schizophrenia*, Norton: New York.
- Szent-Györgyi, A. (1968). *Bioelectronica*. Academic Press: New York and London.
- Szymanski, H.A. (1964). *IR: Theory and Practice of Infra-Red Spectroscopy*. Plenum: New York.
- Tarski, A. (1969/1972). "Truth and Proof", *Scientific American*, June 1969. [Republished in O.Hanfling (1972), *Fundamental Problems of Philosophy*, Blackwell; Oxford. Pages 261-287].
- Tasaki, I. (1939). "The strength-duration relation of the normal, polarized and narcotized nerve fiber". *Amer. J. Physiol.*, **125**, 367-379.
- Tasaki, I. (1952). "Properties of myelinated fibers in frog sciatic nerve and in spinal cord as examined with micro-electrodes". *Jap. J. of Physiology*, **3**, 73-94.
- Tasaki, I. (1953). *Nervous Transmission*. Chas.C.Thomas: Springfield, Ill.
- Tasaki, I. (1968). *Nerve Excitation: A macromolecular approach*. Chas.C.Thomas: Springfield, Ill.
- Teitelbaum, P. (1967). *Physiological Psychology*. Prentice-Hall: Eaglewood Cliffs, NJ.
- Thomas, L.C., L.Austin, and D.R.Davies. (1954). "The examination of nervous tissue by infrared spectrophotometry". *Spectrochim. Acta*, **6**, 320-330.
- Thompson, R.F. (1967). *Foundations of Physiological Psychology*. Harper & Row: London and New York.
- Thomson, W. (1855a). "On the electro-statical capacity of a Leyden phial and of a telegraph wire insulated in the axis of a cylindrical conducting sheath". *Phil. Mag. (series 4)*, **9**, 531-535.
- Thomson, W. (1855b). "On the theory of the electric telegraph". *Proc. Roy. Soc. London*, **7**, 382-399.
- Thorndike, E.L. (1911/1965). *Animal Intelligence: experimental studies*. Hafner Publ. Co.: New York.
- Threadgold, L.T. (1967). *The Ultrastructure of the Animal Cell*. Pergamon Press: Oxford.
- Tinbergen, N. (1951). *The Study of Instinct*. Clarendon Press: Oxford.
- Townsend, R. (1970). *Up the Organization: How to stop the corporation from stifling people and strangling Profits*. M.Joseph: London.

- Traill, R.R. (1970). "Boolean operators: a critique of their conceptual usefulness in modelling adaptable neural nets". In J.Rose, *Progress of Cybernetics*, **2**, 861-871. Gordon & Breach: London and New York.
- Traill, R.R. (1975a). *Thinking as mental model-building: a Piagetian-cum-mechanistic explanation of the 'engram'*. Monograph 12, Institute of Cybernetics, Brunel University. [[www.ondwelle.com/OSM04.pdf](http://www.ondwelle.com/OSM04.pdf)]
- Traill, R.R. (1975b). "Sensori-motor development of object concepts: a mechanistic hypothesis". Paper presented at the tenth annual conference of the Australian Psychological Society, La Trobe University, August 1975. In Traill (1976e), pages 5-10.
- Traill, R.R. (1975c). "Self-construction of personal identity: an extension of the mechanistic mental object hypothesis". Paper presented at the tenth annual conference of the Australian Psychological Society, La Trobe University, August 1975. In Traill (1976e), pages 11-13.
- Traill, R.R. (1976a). "Acquisition of knowledge without transcendental assistance: an extended Piagetian approach". *Kybernetes*, **5**(2), 73-82. [— also Chapters A1 and A2 of this present work, see above — new-page 22].
- Traill, R.R. (1976b). *The gulf between behavioural psychology and fundamental physiology: a systematic attempt to bridge the gap*. Monograph 15, Institute of Cybernetics, Brunel University. (Paper presented at the workshop on Memory during the annual conference of the British Psychological Society, York, April 1976). [[www.ondwelle.com/OSM05.pdf](http://www.ondwelle.com/OSM05.pdf)]
- Traill, R.R. (1976c). *On modelling reality: the 'camera fallacy' in our approach to scientific method, and sometimes to mental functioning*. Paper presented at the annual conference of the British Psychological Society, York, April 1976. [Abstract in *Bull. Brit. Psychol. Soc.*, **29**, 222-223].
- Traill, R.R. (1976d). "Mechanistic modelling: of consciousness?" In Traill (1976e), pages 25-30.
- Traill, R.R. (1976e). *Short papers and letters on the 'linear micro-element' theory of mental mechanism and related questions of Scientific Method*. Monograph 18, Institute of Cybernetics, Brunel University. [www.ondwelle.com/OSM06.pdf](http://www.ondwelle.com/OSM06.pdf)
- Traill, R.R. (1977). *Toward a Theoretical Explanation of electro-chemical interaction in memory-use: the postulated role of infra-red components and molecular evolution*. Monograph 24, Institute of Cybernetics, Brunel University. [— also Part B of this present work, now available online in a separate document: [[www.wbabin.net/physics/traill8.pdf](http://www.wbabin.net/physics/traill8.pdf) or [www.ondwelle.com/MolecMemIR.pdf](http://www.ondwelle.com/MolecMemIR.pdf)]
- Traill, R.R. (1978a). "Analytical theory of sensori-motor spatial development". *Kybernetes*, **7**, 61-71. [— also Chapter A3 of this present work, see above — new-page 35].
- Traill, R.R. (Ref '5/77'). "Toward more valid yet feasible computer-models of biological social systems: the diary of a socio-philosophical programmer". (*Incomplete*).
- Trevarthen, C. (1974). *Intersubjectivity and imitation in infants*. Paper presented at the annual conference of the British Psychological Society, Bangor, April 1974. [Abstract in *Bull. Brit. Psychol. Soc.*, **27**, 185].
- Trevarthen, C. (1975). *New techniques in assessing infant behaviour*. Paper presented at the tenth annual conference of the Australian Psychological Society, La Trobe University, August 1975.
- Trinkaas, J. P. (1969). *Cells into Organs*. Prentice-Hall: Eaglewood Cliffs, NJ.
- Turrell, G. (1972). *Infrared and Raman Spectra of Crystals*. Academic Press: London and New York.
- Tyrrell, S. (1977). *Interaction of medical and social intervention*. Paper presented at the Symposium on Perimeters of Social Repair; Eugenics Society, London, September 1977.
- Venables, P.H. (1963). "Selectivity of attention, withdrawal, and cortical activation". *Archives of General Psychiatry*, **9**, 74-78.
- Venables, P.H. (1964). "Input dysfunction in schizophrenia". In B.A.Maher, *Progress in Experimental Personality Research*, **1**, 1-47. Academic Press: New York.
- Venables, P.H. (1976). *A working model of schizophrenia which fits some of the data*. Paper presented at the annual conference of the British Psychological Society, York, April 1976. [Abstract in *Bull. Brit. Psychol. Soc.*, **29**, 216-217].
- Volkelt, J. (1875). *Die Traum-Phantasie*. Stuttgart.
- Waddington, C.H. (1966). *Principles of Development and Differentiation*. Macmillan: New York.
- Wait, J.R., and D.A.Hill. (1974). "Guided electro-magnetic waves along an axial conductor in a circular tunnel". *IEEE Transactions on Antennas and Propagation*, **AP-22**(4), 627-630

- Waldron, R.A. (1969). *Theory of Guided Electromagnetic Waves*. Van Nostrand Reinhold: London
- Walsh, W.H. (1967). "Kant, Immanuel". In P.Edwards (1967), *Encycl. Phil.*, **4**, 305-324.
- Walter, C.H. (1965/1970). *Traveling Wave Antennas*. Dover: New York.
- Watson, G.N. (1922/1962). *A Treatise on the Theory of Bessel Functions*. Cambridge University Press.
- Watson, J.B. (1919). *Psychology from the standpoint of a Behaviourist*. J.B.Lippincott,Co.: Philadelphia and London.
- Watson, J.B. (1928). *The Ways of Behaviourism*. Harper & bros.: New York and London.
- Watson, J.B. (1931: second edition). *Behaviourism*. Holt, Rinehart & Winston: London.
- Watson, J.B., and W.McDougall. (1928). *The Battle of Behaviourism: an exposition and an exposure*. Psyche Miniatures, General Series, 19: London.
- Watson, W.E. (1914). "Physiology of neuroglia". *Physiol. Rev.*, **54**(2), 245-271.
- Waxman, S.G. (1972). "Regional differentiation of the axon: a review with special reference to the concept of the multiplex neuron" *Brain Research*, **47**, 269-288.
- Webb, S.J., and M.E. Stoneham. (1977). "Resonances between  $10^{11}$  and  $10^{12}$  Hz in active bacterial cells as seen by laser Raman spectroscopy". *Phys. Lett.*, **60A**(3). 267-268.
- Wiener, N (1948/1965). *Cybernetics or Control and Communication in the animal and the machine*. MIT Press: Cambridge, Massachusetts.
- Weiss, P.A. (1969). "The living system: determinism stratified". In Koestler (1969), pages 3-42, and 54-55.
- Wetherick, N.E. (1976/1977). *Consciousness in experimental psychology*. Paper presented at the conference on Consciousness and Conscious Experience, Philosophy of Psychology Group, Windsor, April 1976. Also published in *J. Phenomenological Psychology*, **8**.
- Whitehead, A.N., and B.Russell. (1910, 1912, 1913). *Principia Mathematica* (3 vols.). Cambridge University Press.
- Wickelgren, W .A. (1968). "Sparing of Short Term Memory in an amnesic patient: implications for strength theory of memory". *Neuropsychologia*, **6**, 235-244.
- Wickelgren, W .A. (1970). "Multitrace strength theory". In Norman (1970), pages 65-102 .
- Willshaw, D.J., H.C.Longuet-Higgins, and O.P.Buneman. (1970). *Nature*, **225**, 178.
- Wittgenstein, L. (1921/1961). *Tractatus Logico-Philosophicus*. Routledge and Kegan Paul: London.
- Wittgenstein, L. (1953/1968). *Philosophical Investigations*. Basil Blackwell: Oxford.
- Wolman, B.B. (1970). *Children Without Childhood*. Grune & Stratton: New York and London.
- Woolsey, C.N. (1958). "Organization of somatic sensory and motor areas of the cerebral cortex". In H.F.Harlow and C.N.Woolsey, *Biological and Biochemical Bases of Behavior*. University of Wisconsin Press: Madison, Wis.
- Yerofeeva, M.N. (1916). "Contribution to the study of destructive conditioned reflexes". *Comptes rendus de la societe biologique*, **79**, 239-240.
- Zahn, T.P., D.Rosenthal, and D.Shakow. (1963). "Effects of irregular preparatory intervals on reaction time in schizophrenia". *J. Abn. Soc. Psychol.*, **67**, 44-52.
- Ziman, J.M. (1960). *Electrons and Phonons*. Oxford University Press.