



Wavelengths Switching and Allocation
Algorithms in Multicast Technology using
M-Arity Tree Networks Topology

A thesis submitted in partial fulfilment of the requirements for the
degree of Doctor of Philosophy (PhD) to:
Electronic and Computer Engineering
School of Engineering and Design
Brunel University
United Kingdom

By:

Rafed Sabbar Abbas

August 2014



Wavelengths Switching and Allocation Algorithms in Multicast Technology using M-Arity Tree Networks Topology

A thesis submitted in partial fulfilment of the requirements for the degree of Doctor of Philosophy (PhD) to:
Electronic and Computer Engineering
School of Engineering and Design
Brunel University
United Kingdom

By:

Rafed Sabbar Abbas

Supervised by:

Prof. Hamed S. Al-Raweshidy

August 2014

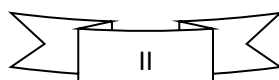



Abstract

In this thesis, the m-arity tree networks have been investigated to derive equations for their nodes, links and required wavelengths. The relationship among all parameters such as leaves nodes, destinations, paths and wavelengths has been found. Three situations have been explored, firstly when just one server and the leaves nodes are destinations, secondly when just one server and all other nodes are destinations, thirdly when all nodes are sources and destinations in the same time. The investigation has included binary, ternary, quaternary and finalized by general equations for all m-arity tree networks.

Moreover, a multicast technology is analysed in this thesis to transmit data carried by specific wavelengths to several clients. Wavelengths multicast switching is well examined to propose split-convert-split-convert (S-C-S-C) multicast switch which consists of light splitters and wavelengths converters. It has reduced group delay by 13% and 29% compared with split-convert (S-C) and split-convert-split (S-C-S) multicast switches respectively. The proposed switch has also increased the received signal power by a significant value which reaches 28% and 26.92% compared with S-C-S and S-C respectively.

In addition, wavelengths allocation algorithms in multicast technology are proposed in this thesis using tree networks topology. Distributed scheme is adopted by placing wavelength assignment controller in all parents' nodes. Two distributed algorithms proposed shortest wavelength assignment (SWA) and highest number of destinations with shortest wavelength assignment (HND-SWA) algorithms to increase the received signal power, decrease group delay and reduce dispersion. The performance of the SWA algorithm was almost better or same as HND-SWA related to the power, dispersion and group delay but they are always better than other two algorithms. The required numbers of wavelengths and their utilised converters have been examined and calculated for the researched algorithms. The HND-SWA has recorded the superior performance compared with other algorithms. It has reduced number of utilised wavelengths up to about 19% and minimized number of the used wavelengths converters up to about 29%.

Finally, the centralised scheme is discussed and researched and proposed a centralised highest number of destinations (CHND) algorithm with static and dynamic scenarios to reduce network capacity decreasing (C_d) after each wavelengths allocation. The CDHND has reduced (C_d) by about 16.7% compared with the other algorithms.

To

His holy majesty the great leader

Imam Mahdi (God Accelerate his reappearance)

And his deputy Grand Ayatollah

Shaikh Mohammed Al-Yaqobi

Dearest Adored Parents

The Merciful Heart "Nahla"

Wonderful Beloved Sisters and Brothers

Lovely Beautiful wife "Zeinab"

ACKNOWLEDGEMENTS

I would like to express my sincere appreciation and gratitude to my father who encouraged me from my childhood to success and get higher education. I hope that he is still alive to see his dream.

I would like to express my deepest gratitude to my mother who spent lot of time to pray for me. Many thanks for your great sacrifices dearest mum. You are a source of inspiration for me in all my life. Without your help, it would not be possible for me to finish the PhD degree.

My lovely and wonderful sisters and brothers, without your tremendous support, help and prayers I would not have made it through my PhD degrees.

I would like to express gratitude and deep thanks to my wife for supporting me at all times and thanks for patiently listening to all of my complaints during the development of this thesis.

I would like to thank my supervisor Professor Hamed Al-Raweshidy for his valuable advices and guidance during the PhD period. He has been very helpful and supportive for all these years.

My gratitude goes to my colleagues in the Wireless Networks and Communications Centre (WNCC), who have been supportive throughout this period. I would like to acknowledge the great attitude of all the staff members that I have interacted with at Brunel University and specifically in the department of Electronic and Computer Engineering.

Contents

Chapter One: Background and Motivations.....	2
1.1 Background.....	2
1.1.1 Wavelength assignment schemes	2
1.1.2 Wavelength Assignment Technologies	3
1.2 Motivations	4
1.3 Aim and Objectives	5
1.4 Contributions to knowledge.....	6
1.5 Organisation of the thesis	8
1.6 References.....	9
Chapter Two: Optical Fibre Communication.....	14
2.1 Introduction	14
2.2 Fibre Attenuation Loss	15
2.3 Chromatic Dispersion.....	16
2.4 Networks Topologies.....	17
2.5 Wavelengths Switching	19
2.6 Centralised and Distributed Algorithms	21
References.....	22
Chapter Three: M-Arity Networks	28
3.1 Introduction	28
3.2 Number of Wavelengths Calculation	29
3.3 Number of Nodes Formula	30
3.4 Tree network	30
3.5 Symmetric Tree Networks (Arity Tree Network)	31
3.6 Symmetric not random networks	32
3.6.1 One-to-Many.....	33
3.6.2 One-to-All	43
3.6.3 All-to-All	48
3.7 Summary	54
References.....	55
Chapter Four: Wavelengths Multicast Switching	61
4.1 Introduction	61
4.2 Wavelengths Splitter	62
4.3 Wavelengths Conversion (WC)	63

4.3.1	Wavelengths Conversion Degree (WCD)	64
4.3.2	Wavelength Conversion Availability (WCA)	64
4.3.3	Conversion Techniques	64
4.3.4	Wavelength Conversion Range (WCR)	66
4.4	Multicast Switch Techniques	81
4.5	Results and Discussion	85
4.6	Summary	89
	References	90
Chapter Five: istributed Wavelengths Assignment Processes		101
5.1	Introduction	101
5.1.1	Local and Metropolitan Networks	104
5.1.2	Single and multimode fibres	105
5.1.3	Why Optical Fibre ?	106
5.1.4	Refraction	107
5.1.5	Factors Governing Refraction	107
5.1.6	Refractive Index (n)	108
5.1.7	Dispersion	109
5.2	Dispersion for Various Wavelengths	111
5.3	State of art	117
5.4	Wavelength assignment algorithms	117
5.4.1	Multicast Wavelength Assignment Algorithm (MWAA)	118
5.4.2	New Greedy Wavelength Assignment (NGWA) algorithm	118
5.4.3	Shortest Wavelength Assignment (SWA) algorithm	118
5.4.4	Highest Number of Destinations with Shortest Wavelength Assignment (HND-SWA) algorithm	120
5.5	Results and Discussion	122
5.6	Summary	128
	References	129
Chapter Six: avelengths and Their Converters Number		136
6.1	Introduction	136
6.1.1	Wavelength	137
6.1.2	Wavelengths Capacity	138
6.1.3	Conversion Cost	139
6.2	Wavelengths assignment algorithms	141

6.3	Results and Discussion	144
6.4	Summary	149
	References.....	149
Chapter Seven: entralsed Wavelengths Assignment Technology		156
7.1	Introduction	156
7.2	Multicast Technology	158
7.3	Tree Network Analysing	158
7.3.1	Network capacity	159
7.3.2	Network Capacity decreasing (Cd) in Multicast	160
7.3.3	Centralised Wavelength Assignment algorithms	160
7.3.3.3	<i>Network Capacity Decreasing</i>	162
7.4	Results and Discussion	165
7.5	Summary.....	167
	References.....	168
Chapter Eight: onclusion and Future Work.....		171
8.1	Conclusion	171
8.1.1	m-arity tree networks	171
8.1.2	Multicast switching.....	172
8.1.3	Distributed Wavelengths Selection	172
8.1.4	Centralised Wavelengths Selection	173
8.2	Future Works.....	173
Author's Publication.....		175

List of Figures

Figure 2- 1: Communication through a medium	14
Figure 2- 2: Attenuation for various wavelengths and the transmission windows in optical fibres	15
Figure 2- 3: Optical network topologies	18
Figure 2- 4: Job of each device (a) Hub, (b) switch and (c) Router	20
Figure 3- 1: Symmetric (Arity ordinal) tree networks (a) Binary (b) Ternary (c) Quaternary	28
Figure 3- 2: N-node linear array network.....	29
Figure 3- 3: Ring network.....	30
Figure 3- 4: One-to-many binary tree network.....	33
Figure 3- 5: Binary tree network.....	34
Figure 3- 6: Ternary tree	37
Figure 3- 7: Quaternary tree.....	40
Figure 3- 8: M-arity network with height h	43
Figure 3- 9: One-to-many Binary tree network	44
Figure 3- 10: All-to-all binary tree network.....	49
Figure 4- 1: Optical fibre splitter one-to-four.....	62
Figure 4- 2: Wavelengths conversion	63
Figure 4- 3: Four wave mixing technique (a) outside, (b) inside	65
Figure 4- 4: Phase changing	68
Figure 4- 5: Frequency difference	68
Figure 4- 6: Four-wave mixing converter in VPI	72
Figure 4- 7: Waves power for various WCR	75
Figure 4- 8: Group delay for various WCR	76
Figure 4- 9: Different methodology of WC.....	77
Figure 4- 10: Wave power for a single converter.....	78
Figure 4- 11: Wave power for two consecutive converters.....	78
Figure 4- 12: Wave power for three consecutive converters	79
Figure 4- 13: Group delay for a single converter	80
Figure 4- 14: Group delay for two consecutive converters	80
Figure 4- 15: Group delay for three consecutive converters.....	81
Figure 4- 16: 2x2 C-S-C-S multicast switch	81
Figure 4- 17: Multicast Switch	82
Figure 4- 18: S-C Wavelengths Multicast Switching.....	83
Figure 4- 19: S-C-S Wavelengths Multicast Switching	84
Figure 4- 20: S-C-S-C Wavelength Multicast Switching	85
Figure 4- 21: Wave power for different wavelengths multicast switches in quaternary tree	85

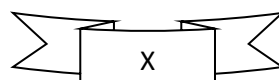

Figure 4- 22: Group delay for different wavelengths multicast switches in quaternary tree	86
Figure 4- 23: Wave power for different converted wavelengths in multicast switches in octonary tree	87
Figure 4- 24: Group delay for different converted wavelengths in multicast switches in octonary tree	87
Figure 4- 25: Wave power for different converted wavelengths in multicast switches in sedenary tree	88
Figure 4- 26: Group delay for different converted wavelengths in multicast switches in sedenary tree	89
Figure 5- 1: Different wavelength assignments scheme (a) static (fixed) (b) dynamic and (c) hybrid scheme.....	101
Figure 5- 2: Different wavelengths assignment types (a) centralised (b) distributed.	103
Figure 5- 3: Two LAN connected by a switch	105
Figure 5- 4: Single-mode and multi-mode fibre types.....	106
Figure 5- 5: Refraction in various medium.....	107
Figure 5- 6: Refraction through a Prism	107
Figure 5- 7: Dispersion for different wavelengths for transmission fibre and the dispersion compensating fibre.....	110
Figure 5- 8: Stander and dispersion shifted.....	111
Figure 5- 9: Dispersion for various wavelengths	112
Figure 5- 10: Power for various wavelengths	113
Figure 5- 11: Analysing wavelengths through 10 km optical fibre	114
Figure 5- 12: Dispersion for various supplied power values	115
Figure 5- 13: Group Delay for various supplied power values.....	116
Figure 5- 14 : Quaternary tree with various wavelengths to different destinations .	119
Figure 5- 15: Quaternary tree network with shortest wavelength assignment (SWA) algorithm	120
Figure 5- 16: Quaternary tree network with highest number of destinations with shortest wavelength (HND-SWA) algorithm	122
Figure 5- 17: Dispersion for various algorithms in binary network	123
Figure 5- 18: Group delay for various algorithms in binary network	124
Figure 5- 19: Signal power for various algorithms in binary network	124
Figure 5- 20: Dispersion for various algorithms in quaternary network.....	125
Figure 5- 21: Signal power for various algorithms in quaternary network.....	125
Figure 5- 22: group delay for various algorithms in quaternary network.....	126
Figure 5- 23: Dispersion for various algorithms in random network	126
Figure 5- 24: Group delay for various algorithms in random network	127
Figure 5- 25: Signal power for various algorithms in random network.....	127

Figure 6- 1: Different types of waves.....	137
Figure 6- 2: Wavelengths converter	140
Figure 6- 3: Ternary tree with different available wavelengths	141
Figure 6- 4: Ternary tree with SWA algorithm	142
Figure 6- 5: Ternary tree with HND-SWA algorithm	144
Figure 6- 6: Number of utilized wavelengths in a binary tree network	144
Figure 6- 7: Number of utilized wavelengths converters in a binary tree network ..	145
Figure 6- 8: Number of utilized wavelengths in a ternary tree network.....	146
Figure 6- 9: Number of utilized wavelengths converters in a ternary tree network .	146
Figure 6- 10: Number of utilized wavelengths in a quaternary tree network.....	147
Figure 6- 11: Number of utilized wavelengths converters in a quaternary tree network.....	147
Figure 6- 12: Number of utilized wavelengths in a random tree network.....	148
Figure 6- 13: Number of utilized wavelengths converters in a random tree network	148
Figure 7- 1: Network capacity decreasing	159
Figure 7- 2: Part of quaternary tree network show network capacity decreasing ...	163
Figure 7- 3: Part of ternary tree network show the capacity decreasing.....	164
Figure 7- 4: Capacity Decreasing in Binary network	166
Figure 7- 5: Capacity Decreasing in Ternary network	166
Figure 7- 6: Capacity Decreasing in Random tree	167

List of Tables

Table 1-1: Wavelength range used in different fibre types	4
Table 3- 1: M-ary numbering	31
Table 3- 2: Number of nodes, links, destinations and leaf nodes per each level in one-to-many binary tree network.....	34
Table 3- 3: Number of nodes, links, destinations and leaf nodes per each level in one-to-many ternary tree network	37
Table 3- 4: Number of nodes, links, destinations and leaf nodes per each level in one-to-many quaternary tree network	40
Table 3- 5: Number of nodes, links, destinations and leaf nodes per each level in one-to-all binary tree network.....	44
Table 3- 6: Number of nodes, links, destinations and leaf nodes per each level in one-to-all ternary tree network	46
Table 3- 7: Number of nodes, links, destinations and leaf nodes per each level in one-to-all quaternary tree network	47
Table 3- 8: Number of nodes, links, destinations and leaf nodes per each level in all-to-all binary tree network	49
Table 3- 9: Number of nodes, links, destinations and leaf nodes per each level in all-to-all ternary tree network.....	51
Table 3- 10: Number of nodes, links, destinations and leaf nodes per each level in all-to-all quaternary tree network	53
Table 4- 1: Wavelengths Conversion Setup	73
Table 4- 2: Wavelengths to frequencies conversion.....	75
Table 4- 3: Three WCs methods setup.....	80
Table 5- 1: Dispersion, Group Delay and Power for 10 and 30 km at 1300 and 1550 nm	116
Table 5- 2: quaternary tree as a table	119

Chapter one

Background and Motivations

Brief background of the wavelength assignment is presented in this chapter. Motivations of this work, aim and objectives are well demonstrated in this chapter. Furthermore, the procedures and processes to achieve the main contributions of this research are described. Finally, the remaining chapters in this thesis are outlined and overviewed.

1.1 Background

Wavelength division multiplexing (WDM) has made a real revolution in the optical fibre networks by supporting a high number of channels (wavelengths) in the optical fibres. According to the huge number of wavelengths supported by WDM, each specific candidate wavelength has to carry data from source to specific client. Therefore, wavelength assignment (WA) is defined [1] as the wavelength chosen in the light path between their source and destination/s. The number of wavelengths supported by WDM is varied from one fibre type to another and which type of WDM has been used (CWD or DWDM). However, the latest number of wavelengths transmitted with WDM [2] using single fibre is 432 wavelengths with a capacity of 171 Gb/s.

1.1.1 Wavelengths assignment schemes

Wavelength assignment schemes can be divided into three schemes [3] static, dynamic and hybrid. In the static wavelength assignment (SWA) scheme, a specific wavelength is dedicated to each destination; therefore, the number of destinations is equal to the number of available wavelengths in the network or vice versa. However, it is used in the small and limited networks and it is also used in the sensitive networks when the wavelength always needs to be available like health and military use.

The dynamic wavelength assignment (DWA) scheme assigns wavelengths to destinations based on the required data transfer? Thus it is allowing each wavelength to be assigned to different target at various times. Therefore, it utilizes the network resources in a more efficient way. The hybrid wavelength assignment (HWA) scheme is basically a compilation of these two schemes (static and dynamic).

Wavelength-routed all-optical WDM network [4] is considered to be a favourable nominee for the next generation of wide-area backbone networks. The knowledge of the huge increase in the global data transmission [5] which is approaching 11.2 Exabyte (EB) in the next four years (2017), provides a high motivation to develop telecommunication networks using superior enhanced wavelength assignment algorithms in WDM technology.

Wavelength assignment WDM technology increases network capacity of number of calls by significantly increasing transmission using several different signals in a single fibre [6-9] and a sufficient algorithm to allocate the fitted wavelength in this fibre is proposed.

In multi-fibre [10-12] environment, every link contains multiple fibres. Therefore, the same wavelength can be transmitted in the same link provided that they use different fibres. By utilizing multi-fibre methodology, the wavelengths will be re-used sundry times and the number of served calls will be maximized in the optical fibre network.

1.1.2 Wavelengths Assignment Technologies

Wavelength allocation can be made to just a single destination [13] when the data is restricted to one client and no any other customer can receive the carried information, and this process called uni-cast. The method which chooses wavelength/s to send data from one source to several users (encoded to one group) at the same time [14], is called multicast. This procedure has been adopted by the research in this thesis. There is another technique to transmit wavelength carrying information (especially radio and TV programmes) [15] to the public and generally for any client who likes to receive these telecast, which is called broadcast.

Wavelength ranges (bands) that have been used in WDM are various from 1260 nm – 1660 nm [16], while wavelengths that are used are depending on different types of optic fibres. They utilize dissimilar band of wavelengths for downstream and upstream (table 1.1) data transmission, to minimize the attenuation caused by scattering and absorption.

Plastic Optical Fibre (POF)	Multimode Graded Index Fibre	Single-mode Fibre
650 nm		
850 nm	850 nm	
	1300 nm	1300 nm
		1550 nm

Table 1-1: Wavelength range used in different fibre types

1.2 Motivations

According to the great insistence demand for the ultra-wide bandwidth and huge network capacity, the wavelength assignment algorithms in WDM technology have been a tremendously active topic for a large amount of scientific researches. There is a large number of researches focused on different targets in this technique especially on saving energy [17-20], quality of service (QoS) [21-23], blocking probability or network capacity [24-26], number of utilized wavelength's converters [27] and number of needed wavelengths [28].

The essential motivation behind the work in this thesis is to save energy of the optical network by decreasing number of used wavelength's converters (WC), increasing network capacity (NC) by minimizing the decrease in network capacity after each wavelength assignment (WA), reducing the network cost by minimize number of applied wavelengths and finally maximizing QoS by reducing wavelength conversion range (WCR) as much as possible which leads to the reduction of dispersion in the output wavelength from its converter.

- 1) Cost is the main topic in any optical network which is required to be designed. At any time, price is very important for all customers and if any company needs more users then it has to reduce the expense of its service as much as it can. Many researchers have tried to minimize. Their network cost by different techniques and procedures. Wavelength converters are extremely expensive devices in the active optical network. In this research, network cost is decreased by reducing the number of used wavelength converters.
- 2) One of the prime reasons to preferring optical fibre network to the other wired and wireless networks is because of the high number of calls (capacity) that can be served. Several hundreds of wavelengths can carry calls from source to various clients using just one single fibre. This huge bandwidth has to be

utilized by intelligent methods to save and to avoid wasting the resources of this network. Therefore, this work has taken this issue into consideration to save network capacity by using a smart wavelength assignment algorithm.

- 3) Environment needs help! As a result of emissions to the environment of harmful gases like CO_2 which affects the climate, it needs help. One of the main sources of these pollutants to the environment is non-clean power generation plants. Therefore, reducing the energy is necessary and urgent to preserve the environment in which we live. Reducing energy was and is still the main cause of a lot of research in various fields. The objective is to reach the clean and pure environment which has significant positive effects on the health of all creatures. That provides a motivation to make a part of our research on energy saving and how this work can reduce consumed energy as much as possible.
- 4) The revolution in the new and continuously improving technologies is concentrating on providing pleasure and enjoyment to the clients. One of these objectives is quality of service (QoS) which is applied for the telecommunication generally and on the computer network specially. QoS term refers to the ability of the network to provide a better service for the end user using different technologies. QoS includes all the parts which leads to a perfect connection, such as less dispersion, decrease the cross-talk, minimizing response time, no or less lost data, reduction of signal-to-noise ratio, and so on. Thus the QoS was one of the motivations behind this work.

1.3 Aim and Objectives

The aim of the research presented in this thesis is to find appropriate wavelength assignment algorithm using multicast technology in tree network topology in WDM optical fibre to increase network capacity, minimize network cost and network power consumption and enhance provided quality of service. In other words the aim is to design a new processing to assign wavelength to each coming call by using an optimized algorithm in multicast tree networks.

To achieve this aim, the objectives are constructed and arranged as follows below:

- a) Find the adequate network topology to be designed and investigated using the convenient algorithm to capture the compatible wavelength.
- b) Derive equations to calculate the prerequisite wavelengths to supply destinations and number of necessary devices (routers, switches, wavelength converters...etc.) to carry data from their source to clients.
- c) Investigate the suitable wavelengths assignment proposing various methods to improve network performance. Wavelength continuity constraint is required for the centralized processing scheme, therefore it is considered for the localised wavelength assignment. In this agenda, the passive optical term is taken in account. Passive components (light splitters, optical fibres, WDM, isolators, circulators...etc.) have been built in the passive network designs.
- d) To ensure that the network capacity after each allocation is reduced as minimally as possible to maintain its availability to feed destinations. This is achieved by choosing the wavelength that has the highest number of destinations.
- e) Design energy and quality saver switch to dispense wavelengths to all required users. VPI modulator is used to build the proposed switch in the wavelength assignment network to display the power consumption, dispersion and group delay.
- f) To offer a wavelength selection technique using a distributed scheme. In this programme the active optical expression is adopted. The main active components (wavelengths converters (WC), routers, switch...etc.) have been considered in this project.
- g) Overcome the expenditure of the distributed wavelength allocation method by concentrating on reducing the number of utilized WCs. Number of used wavelengths is also decreased to constrict the network outlays.

1.4 Contributions to knowledge

Almost all network topologies that have been studied by most researches can be divided into three cases. The first is the mesh network, which has been investigated in several research using NJ-LATA, USNET, NSFNET [29], while,

other work has investigated the second topology which is called ring network [30]. Third topology which is called tree network has been examined [31] using random design of trees.

The first contribution of this work is to propose symmetric (Ary or arity) tree networks. In the symmetric (Ary or Arity) tree networks, all nodes in the network (except leaf nodes) have a specific number of children such as binary, ternary, quaternary...etc. In the binary tree network, all nodes (except leaf nodes) have two connected children. While in the ternary tree network, all nodes (except leaf nodes) have three children. The network capacity (accepted calls) has been explored and equations have been derived for these Arity networks. The number of needed wavelengths to serve calls and the number of nodes for these symmetric networks are calculated by these derived equations. Various cases for these networks are presumed (one-to-many, one-to-all and all-to-all cast).

The fundamental contributions of this research are to assume appropriate wavelengths assignment (WA) in WDM optical fibre networks in two scenarios (centralized and distributed). DWA is a proficient technique to select an appropriate wavelength from source to clients. The centralized wavelength assignment (CWA) algorithm has been proposed to save network capacity (number of calls can be served) by minimizing number of utilised wavelengths and reducing the decrease in network capacity after each wavelength assignment.

In the distributed wavelengths allocation (DWA), active devices have been used such as wavelength converters. Therefore, it concentrates in its processing to minimize the number of used converters to save cost and energy. Other contribution in the DWA is to increase quality of service (QoS) by choosing the shortest wavelength. That will maximize wavelength power, which leads to minimizing dispersion in the converted wavelength. The number of utilized wavelengths has been shrunk in the proposed DWA.

The other contribution is to propose a new multicast wavelength switch. This switch has reduced wavelength conversion range (WCR) which is the difference between the input and the output wavelength. This idea has helped also to

minimize dispersion which is caused by high WCR. This leads also to obtain better QoS.

1.5 Organisation of the thesis

The research in this thesis is about the wavelengths switching and assignment in optical fibre. It consists of eight chapters. The chapters are inter-dependant and therefore the reader has to read them in details and follow them sequentially. The first chapter contains an introduction about the whole thesis subject. It includes also the main aim of this research work, objectives, motivations and contributions. The second chapter is about the previous works and related research. It also comprises a history for this work and an overview on the wavelengths switching and assignment in various tree networks in optical fibres.

The third chapter presents the analysis of the tree networks and their types. The symmetric tree networks are the adopted topologies and the number of required nodes, links wavelengths equations have been derived and formulated. However, the fourth chapter investigates the wavelength multicast switching using light splitters and wavelengths converters. The proposed multicast switch is compared with two other switches. The main advantages of using our proposed switch are to increase the transmitted wave's power and reduce the group delay. Moreover, it has decreased the number of wavelengths converters which are very expensive energy consumption devices. The fifth chapter has investigated the wavelengths assignment in distributed scheme and proposed a new algorithm to multicast wavelengths to different destinations. The new algorithm has concentrated on increasing signal power, minimize group delay and dispersion.

The sixth chapter investigates the effect of the wavelengths allocation algorithm on the number of required wavelengths to carry multi-casted data from source to various clients. It also investigates how to reduce the number of wavelengths converters in multicast technology. It works on the distributed scheme when the wavelengths selection is processed in all parents' nodes. The seventh chapter contains the wavelength assignment algorithm for multicast technology in a centralised scheme. This scheme is proposed to simplify the multicast network and reduce its expense. The eighth chapter holds the conclusion and the future work.

1.6 References

- [1] Kavitha, E.; Sreenivasa Rao, D.; "Dynamic wavelength allocation in WDM optical networks", (*IJCSE*) *International Journal on Computer Science and Engineering*, vol. 02, no. 09, pp. 2900-2904, Sep 2010.
- [2] Nippon Telegraph and Telephone (NTT), " 69.1-Tbit/s Optical Transmission Technology Using Digital Coherent Multilevel QAM Format", NTT Network Innovation Laboratories, [available] online on: http://www.ntt.co.jp/RD/OFIS/active/2010pdf/pdf/h_nw06_e.pdf, accessed on Aug 2013.
- [3] Yueping Cai; Matsuura, M.; Kishi, N.; Miki, T., "Hybrid static-dynamic wavelength/waveband allocation scheme for novel broadcast and select star-ring optical regional network," *Communications, 2007. APCC 2007. Asia-Pacific Conference on*, vol., no., pp.513-516, 18-20 Oct. 2007.
- [4] Chatterjee, M.; Barat, S.; Majumder, D.; Bhattacharya, U., "New strategies for static routing and wavelength assignment in de Bruijn WDM networks," *Communication Systems and Networks (COMSNETS), 2011 Third International Conference on* , vol., no., pp.1-4, 4-8 Jan. 2011.
- [5] Vlachos, N., King, P., "Internet Traffic Classification and Features: Current Levels and Future Projections, 14th Annual Post Graduate Symposium on the Convergence of Telecommunications, Network and Broadcasting, Crowne Plaza Hotel, Liverpool, vol., no., pp., 24th-25th June 2013.
- [6] Lopez, E.T.; Lazaro, J.A.; Polo, V.; Prat, J., "Bandwidth assignment criteria against Rayleigh Backscattering effect in TDM-PON single-fibre wavelength-reuse networks," *Transparent Optical Networks (ICTON), 2011 13th International Conference on*, vol., no., pp.1-4, 26-30 June 2011.
- [7] Chatterjee, B.C.; Sarma, N.; Sahu, P.P., "Priority based routing and wavelength assignment with traffic grooming for optical networks," *Optical Communications and Networking, IEEE/OSA Journal of*, vol.4, no.6, pp.480-489, June 2012.

- [8] Rashedi, A.; Kavian, Y.S.; Ghassemlooy, Z., "Artificial Bee Colony model for routing and wavelength assignment problem," *Transparent Optical Networks (ICTON), 2011 13th International Conference on*, vol., no., pp.1-5, 26-30 June 2011.
- [9] Singal, A.; Kaler, R. S., "Performance Evaluation of Algorithms for Wavelength Assignment in Optical Ring Network," *Advanced Computing & Communication Technologies (ACCT), 2012 Second International Conference on*, vol., no., pp.161,166, 7-8 Jan. 2012.
- [10] Coiro, A.; Listanti, M.; Valenti, A.; Matera, F., "Power-Aware Routing and Wavelength Assignment in Multi-Fibre Optical Networks," *Optical Communications and Networking, IEEE/OSA Journal of*, vol.3, no.11, pp.816-829, November 2011.
- [11] Bampas, E.; Pagourtzis, A.; Pierrakos, G.; Potika, K., "On a Noncooperative Model for Wavelength Assignment in Multifiber Optical Networks," *Networking, IEEE/ACM Transactions on*, vol.20, no.4, pp.1125-1137, Aug. 2012.
- [12] Dewiani; Hirata, K.; Higami, Y.; Kobayashi, S.-Y., "Dynamic routing and wavelength assignment in multifiber WDM networks with sparse wavelength conversion," *ICT Convergence (ICTC), 2012 International Conference on*, vol., no., pp.567-572, 15-17 Oct. 2012.
- [13] Patel, A.N.; Ji, P.N.; Jue, J.P.; Ting Wang, "Routing, wavelength assignment, and spectrum allocation in wavelength-convertible flexible optical WDM (WC-FWDM) networks," *Optical Fibre Communication Conference and Exposition (OFC/NFOEC), 2012 and the National Fibre Optic Engineers Conference*, vol., no., pp.1-3, 4-8 March 2012.
- [14] Daldoul, Y.; Ahmed, T.; Meddour, Djamel-Eddine, "IEEE 802.11n aggregation performance study for the multicast," *Wireless Days (WD), 2011 IFIP*, vol., no., pp.1-6, 10-12 Oct. 2011.
- [15] Penhoat, J.; Guillouard, K.; Bonjour, S.; Lemlouma, T., "Definition of a context-aware broadcasting method," *Wireless Personal Multimedia Communications (WPMC), 2011 14th International Symposium on*, vol., no., pp.1-5, 3-7 Oct. 2011.
- [16] Hayes, J.; " Understanding Wavelengths in Fibre Optics", *The Fibre Optic Association, Inc.*, [available] online on: <http://www.thefoa.org/tech/wavelength.htm>, accessed on Aug 2013.

- [17] Ricciardi, S.; Careglio, D.; Palmieri, F.; Fiore, U.; Santos-Boada, G.; Sole-Pareta, J., "Energy-Aware RWA for WDM Networks with Dual Power Sources," *Communications (ICC), 2011 IEEE International Conference on*, vol., no., pp.1-6, 5-9 June 2011.
- [18] Zuqing Zhu; Xiaoliang Chen; Fan Ji; Liang Zhang; Farahmand, F.; Jue, J.P., "Energy-Efficient Translucent Optical Transport Networks With Mixed Regenerator Placement," *Lightwave Technology, Journal of*, vol.30, no.19, pp.3147-3156, Oct.1, 2012.
- [19] Rui Wang; Han Hyub Lee; Sang Soo Lee; Mukherjee, B., "Energy saving via dynamic wavelength sharing in WDM-PON," *Optical Network Design and Modeling (ONDM), 2013 17th International Conference on*, vol., no., pp.235-239, 16-19 April 2013.
- [20] Bianco, A.; Bonetto, E.; Ahmad, A., "Energy awareness in the design of optical core networks," *Optical Fibre Communication Conference and Exposition and the National Fibre Optic Engineers Conference (OFC/NFOEC), 2013*, vol., no., pp.1-3, 17-21 March 2013.
- [21] Ramesh Kumar, K.; Banu, R.S.D.W., "A novel QoS aware crosstalk reducing routing wavelength assignment in all optical networks with path protection consideration," *Communications and Signal Processing (ICCSP), 2012 International Conference on*, vol., no., pp.47-51, 4-5 April 2012.
- [22] Radivojevic, Mirjana R.; Matavulj, Petar S., "Highly flexible and efficient model for QoS provisioning in WDM EPON," *Optical Communications and Networking, IEEE/OSA Journal of*, vol.5, no.8, pp.921-931, Aug. 2013.
- [23] Souza, F.S.H.; Guidoni, D.L.; Mateus, G.R., "Formulations for the RWA problem with traffic grooming, protection and QoS in WDM optical networks," *Computers and Communications (ISCC), 2012 IEEE Symposium on*, vol., no., pp.000265-000270, 1-4 July 2012.
- [24] He, J.; Brandt-Pearce, M.; Subramaniam, S.S., "Analysis of Blocking Probability for First-Fit Wavelength Assignment in Transmission-Impaired Optical Networks," *Optical Communications and Networking, IEEE/OSA Journal of*, vol.3, no.5, pp.411-425, May 2011.
- [25] Chaiwong, K.; Wichaidit, S.; Phromsuphorn, P.; Wardkein, P., "Performance analysis of node architecture in WDM mesh network," *Advanced Communication*

- Technology (ICACT), 2013 15th International Conference on*, vol., no., pp.128-132, 27-30 Jan. 2013.
- [26] Xin Wang; Balasis, F.; Sugang Xu; Tanaka, Y., "Distributed GMPLS optical control in translucent wavelength convertible WDM networks," *Network Operations and Management Symposium (APNOMS), 2012 14th Asia-Pacific*, vol., no., pp.1-8, 25-27 Sept. 2012.
- [27] Iyer, S.; Singh, S.P., "A novel offline PLI-RWA, regenerator placement and wavelength converter placement algorithm for translucent optical WDM networks," *Signal Processing and Communications (SPCOM), 2012 International Conference on*, vol., no., pp.1-5, 22-25 July 2012.
- [28] Keri, M.; Oki, E.; Matsuura, M., "Wavelength Assignment in Multi-Carrier Distributed Optical Ring Networks with Wavelength Reuse," *Optical Communications and Networking, IEEE/OSA Journal of*, vol.3, no.4, pp.281-289, April 2011.
- [29] Saleh, M.A.; Kamal, A.E., "Approximation Algorithms for Many-to-Many Traffic Grooming in Optical WDM Networks," *Networking, IEEE/ACM Transactions on*, vol.20, no.5, pp.1527-1540, Oct. 2012.
- [30] Kadohata, A.; Tanaka, T.; Inuzuka, F.; Watanabe, A.; Hirano, A., "Wavelength defragmentation algorithm for transparent multi-ring networks with multiple fibres per link," *Optical Fibre Communication Conference and Exposition and the National Fibre Optic Engineers Conference (OFC/NFOEC), 2013*, vol., no., pp.1-3, 17-21 March 2013.
- [31] Bampas, E.; Pagourtzis, A.; Pierrakos, G.; Potika, K., "On a Noncooperative Model for Wavelength Assignment in Multifiber Optical Networks," *Networking, IEEE/ACM Transactions on*, vol.20, no.4, pp.1125-1137, Aug. 2012.

Chapter two

Optical Fibre Communication

2.1 Introduction

In the communication system, a signal is transferred from one device called transmitter to another device in the second side called receiver. The data is transmitted from one end user to other through a medium (wireless, optical, copper... etc.) [1]

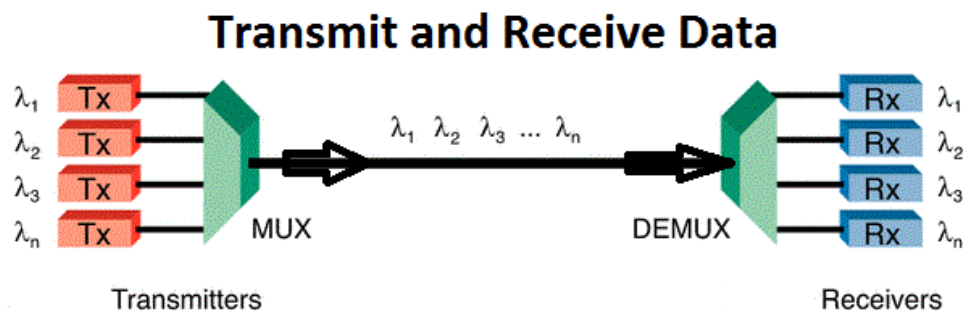

Figure 2- 1: Communication through a medium

The first phenomenon of light transmission through a medium was discovered in 1854, while the first glass fibre was made in the 1920s and their practical use has been started in 1950s. The optical fibre communication was mainly used in medical applications about 1970.

The optical communication had a very high loss about (1000 dB/km) and it was reduced by the end of 1970s to reach just (0.2 dB/km) in the region of 1550 nm. The first microwave system was implemented in 1948 to carry about 100 Mb/s at frequency of 4 GHz. The data rate in coaxial system was increased to about 274 Mb/s in 1975. [2]

2.2 Fibre Attenuation Loss

Transmission through the fibre optic suffers from attenuation for the far distance and the attenuation is directly proportional to the length of the fibre and inversely proportional with the transmitted wavelength. The main acceptable range of wavelengths in optical fibre is 1300 to 1600 nm and the attenuation can be formulated in equation below: [3]

$$\alpha = A \frac{1}{\lambda^4} + B + C \quad (2.1)$$

Where,

(A) is the Rayleigh scattering coefficient

(B) is the combined wavelength-independent scattering loss

(C(λ)) is all the other wavelength-dependent loss

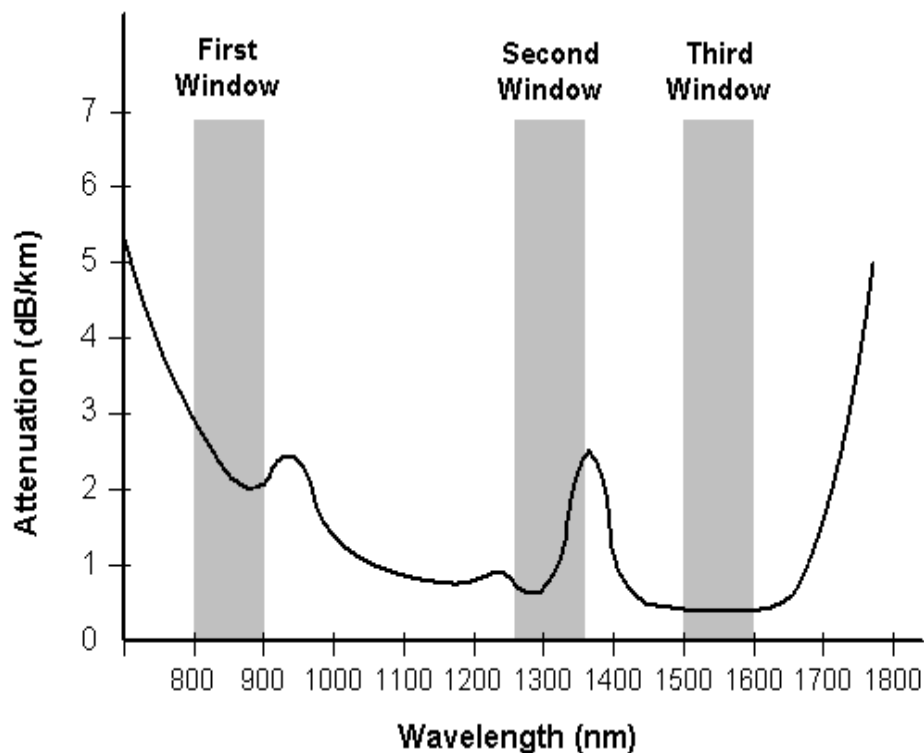

Figure 2- 2: Attenuation for various wavelengths and the transmission windows in optical fibres [4]

2.3 Chromatic Dispersion

The dispersion is generally defined as the separation of a wave into its components according to a given characteristic such as wavelengths. The dispersion in single-mode fibre is divided to a material and waveguide dispersion. The material dispersion is caused by the material that the fibre is made from. While the waveguide dispersion is caused by the wavelength effects and it is directly proportional to the wavelength and inversely proportional to the radius of the single-mode fibre. There is another dispersion type called polarization mode dispersion (PMD) which is caused by the polarization of the different components of the signal. They travel at different speeds because of the various refractions of the components when they refract off the glass. [5]

The dispersion is investigated in different works to be reduced. The length of fibre has reached 100 km to transmit 10 Gbps with the minimum bit error rate (10^{-40}) using wavelength of 1550 nm. The single-mode fibre (SMF) and dispersion compensating fibre (DCF) has been used to get a best performance. [6]

Dispersion is managed in four-wave mixing (FWM) by using orthogonal frequency division multiplexing (OFDM) system with an optical phase conjunction module. [7].

According to the high effect of the dispersion on the quality of the signals and detecting signal in the receiver, the work has investigated the reduction of dispersion. It is minimized by modifying the radius of the fibre and using single-mode fibre [with $\text{SiO}_2:\text{GeO}_2$ (13.5) core and SiO_2 cladding] [8]. The polarization mode dispersion (PMD) is investigated using 40-Gbps-per-wavelength system. The wavelengths used are the C band, which are centralized in 1550 nm and they are transmitted to distances as far as 2852 km. [9].

A high data rate is transmitted in the system and the PMD value is improved using WDM. It is based on the concept of splitting optical signals into fast and slow polarization components and improving the slow one while using the fast one for the output [10]. The effect of the temperature on the chromatic dispersion is analysed for the 40-Gbps system. The experiment is demonstrated through six types of optical

fibres [11]. The chromatic dispersion compensation (CD) is investigated in passive optical network for up to 68 km. The pre and post-compensation is implemented by using fibre Bragg grating in WDM. [12]

2.4 Networks Topologies

The optical fibre networks are investigated in various topologies for different benefits and to obtain several advantages in their performance. There are six famous network topologies in optical fibre technology listed below:

- a. The bus network in which each node (computer or other devices) is connected to the central optical fibre, cable or link called the bus.
- b. The star network topology is a central server connected to all the workstations directly.
- c. The ring network topology is when the computers are connected in a circle loop configuration. Each workstation is directly connected to two others. The remaining workstations are indirectly connected and the data is passing through one or more nodes to reach destination.
- d. The token protocol is used in a star or ring topology, and the signal passes in only one direction.
- e. The mesh network topology is one of two configurations, first one called full mesh and the second called partial mesh. In the full mesh topology, each computer is connected directly to all the other nodes. In the partial mesh topology, some workstations are connected to all the other nodes, and some are connected only to those others which they exchange the most data.
- f. The tree network topology consists of two or more star networks connected to each other. The central computers of the star networks are connected to a main bus.

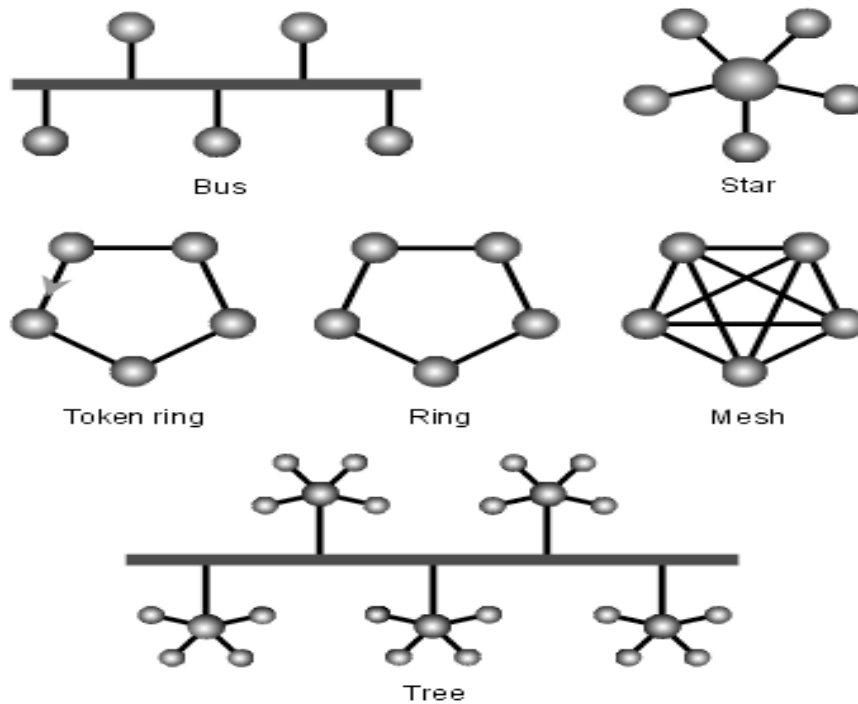

Figure 2- 3: Optical network topologies [13]

The algorithms differ according to the topology of the examined network. The failure protection in conventional passive optical networks is investigated for the tree and ring topologies. WDM-PONs is implemented in the network's architectures to review their performance and how to overcome the fibre links failure in these two topologies. [14]

Four topologies of networks (bus, star, tree and ring) are investigated to explore the signal quality factor, received power, the maximum number of users supported for different input signal's powers. The 10-Gbps data rate is transmitted to prove that the tree network topology provides a low-cost solution for a large geographical area. [15] Ring and partial mesh networks are examined to improve the power consumed to transmit optical fibre signals. [16]

Point-to-multipoint technology in a tree topology optical access network is investigated. [17] Optical ring network has been implemented using multiple fibres [18], waveband switching [19], to minimize switching cost [20] or to minimize transceivers cost and number of wavelengths. [21]

A Binary tree is implemented to investigate transmission delay combined to the classical bottom-up calculation of the channel transfer function. [22] Topology inference is discussed to avoid the problem of anonymous routers. [23] A distributed multicast technology is researched in tree network for the internet to increase the number of nodes on the topology. [24] The tree network is designed to investigate certain asymptotic properties of impulse response in periodic distributed network. [25]

A bus and a star [26] topology are investigated in a controller area network (CAN), while Amrinder, Suresh and Choi have studied linear and ring topologies to reduce number of hops and the traffic delay. [27] The mesh network has been investigated using two heuristic algorithms in group-cast technology [28], while dynamic multicast technology in mesh network was investigated to minimize blocking probability for two schemes. [29]

2.5 Wavelengths Switching

In telecommunication technology, one user (e.g. computer) can connect with another user using a medium (cable, fibre...etc.), while three users need three fibres to connect all users with each other. Four users need six fibres to connect all users with each other and that can reach up to about $(\frac{N(N-1)}{2})$ for N users. That will lead to a large amount of fibres where some fibres will be rarely used. Therefore switches have to be provided to overcome this problem. [30]

Switches work in layer 2 and 3 to connect nodes with each other and enable data to reach their address with different local area networks (LAN) [31]. There are switch, router and hub in a network and they have different performances. Hub is the device that the data is broadcasted to all devices connected to it, even if some devices are not meant to receive these data. However, switch connects different computers in LAN and sends data to a specific destination. Using switches in a network increases its performance and security. A router is used to connect several networks (at least two) and it works in layer 2 (data link layer) to forward data to the best route. [32].

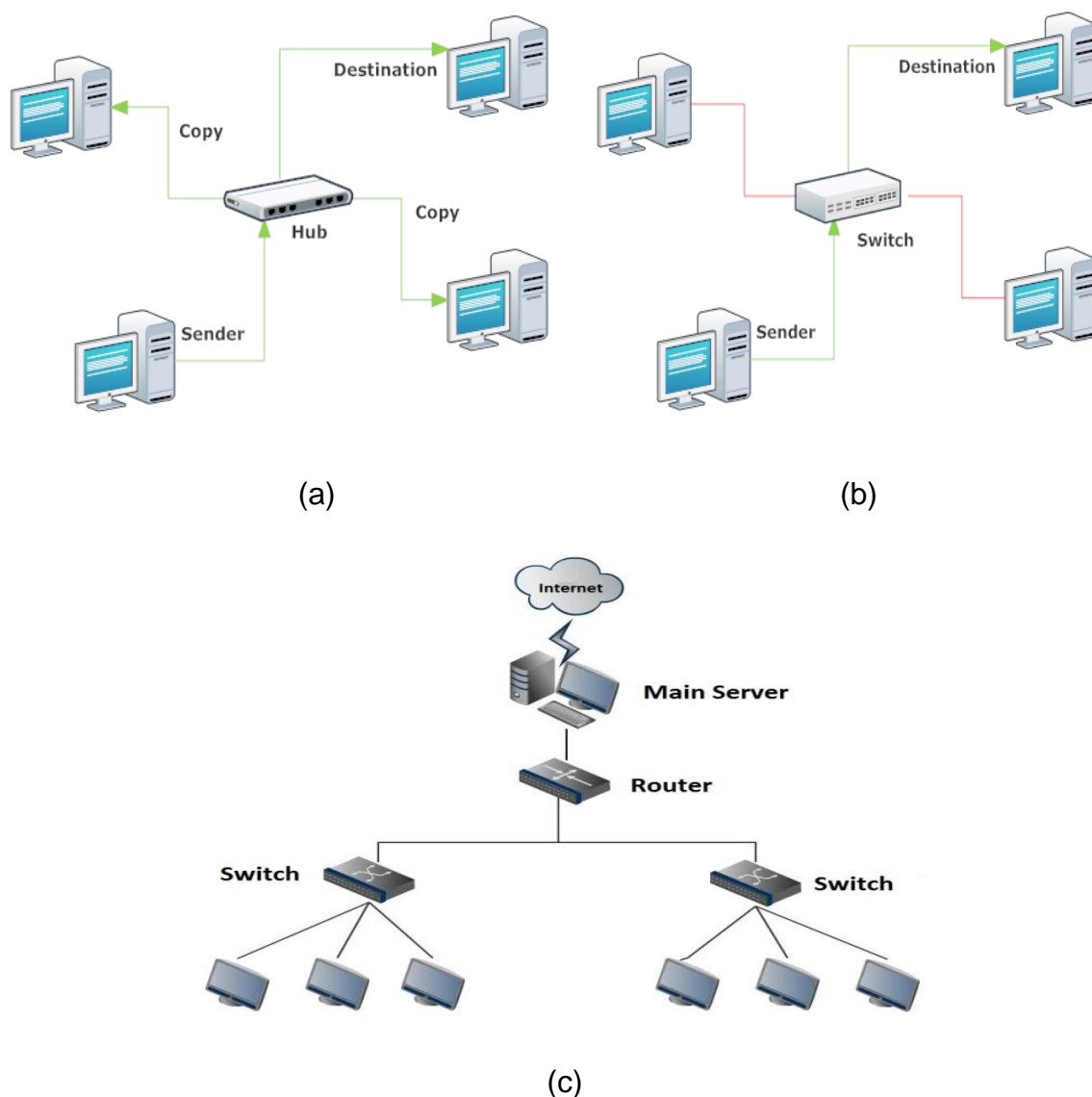

Figure 2- 4: Job of each device (a) Hub, (b) switch and (c) Router [33]

Dynamic waveband switching is investigated using time and wavelength division multiplexer to obtain high throughput and less delay [34]. The wavelength switching is proposed in all-optical routing with passively routed optical data based on their wavelengths. They use wavelength division multiplexing scheme to efficiently route multicast optical packets to reduce energy consumption, power and transmission delay [35]. Sub-wavelength technology is implemented by dividing a wavelength into parts according to time slots. The automatic switched optical network (ASON) based on synchronous digital hierarchy (SDH) is employed in the backbone network [36]. Multicast is compared with unicast technology to improve network performance related to the packet loss probability [37]. The pump-wavelength selection in an

optical packet switching (OPS) with parametric wavelength converters (PWC), which is proposed to maximize successfully transmitted packets. PWC can provide a multiple wavelength conversion and choosing a pump-wavelength selection can convert any wavelength in the both downstream and upstream [38]. Wavelength switching is proposed using optical packet switch (OPS) to reduce wavelength conversion complexity. They have used splitting-converting (S-C) methodology to transmit input wavelengths to different output links [39].

2.6 Centralised and Distributed Algorithms

Centralised algorithm is represented by a central control in a special node in the network and it performs all the network's processes and holds the whole network information such as links situations, nodes status, and wavelengths utilization ...etc. It proceeds enquires to the control centre which chooses a certain wavelength to transmit data from source to destination. In the distributed algorithm, the wavelength reservation control is placed in all parent nodes. Each parent node selects the appropriate wavelength to its children. The information for all children nodes is stored in their parent nodes. Therefore it is called a distributed algorithm because the controllers are distributed throughout whole network. The centralised algorithm is simple to implement because it does not need information exchange from each node for computing but it is still effective in small size networks. Moreover, the centralised algorithm has lower blocking probability because the central controller knows the update information of the whole network. But the centralised algorithm is unreinforced due to the existence of the single point of failure. When any washout happens in the central controller, the whole network will not work properly. The other disadvantage of the centralised algorithm is that it lacks of scalability. When the network is great the large user information needs to be transmitted and the signalling information has to be recorded and stored in the central control. This leads to an increase computing time which will result in the bottleneck for the whole network [40]. Centralised algorithm is expensive [41].

References

- [1] S. C. Gupta, "TEXTBOOK ON OPTICAL FIBER COMMUNICATION AND ITS APPLICATIONS", PHI Learning Pvt. Ltd., vol., Ed. 2, pp. 1-3, Apr. 2012.
- [2] Govind P. Agrawal, "Fibre-Optic Communication Systems", Wiley Series in Microwave and Optical Engineering, John Wiley & Sons, vol. 222, Ed. 4, pp. 3-9, Feb. 2012.
- [3] Alexis Mendez, T. F. Morse, "Specialty Optical Fibers Handbook", Academic Press, vol., no., pp. 36, Oct. 2011.
- [4] Maccao communication, online available: http://maccao.communications.museum/eng/exhibition/secondfloor/moreinfo/2_8_3_OpticalFibres.html, accessed Apr. 2014.
- [5] Ajoy Ghatak; K. Thyagarajan, "Optical Waveguides and Fibers", fundamentals of photonics, University of Connecticut, vol., no., pp. 268-276, 2000.
- [6] Miziya, K.; Sudheer, S.K.; Kuriakose, A.C., "Characterization of an optical communication system utilizing dispersion compensating fibre and nonlinear optical effects," Computing, Communications and Networking Technologies (ICCCNT), 2013 Fourth International Conference on , vol., no., pp.1,6, 4-6 July 2013.
- [7] Pechenkin, V.; Fair, I.J., "On Four-Wave Mixing Suppression in Dispersion-Managed Fibre-Optic OFDM Systems with an Optical Phase Conjugation Module," Lightwave Technology, Journal of, vol.29, no.11, pp.1678-1691, June1, 2011.
- [8] Ebadi, A.; Seraji, F.E.; Mohajerani, E.; Darvishi, S., "Study of dispersion and its relationship with power confinement in a single-mode optical fibre," Laser and Fibre-Optical Networks Modeling (LFNM), 2011 11th International Conference on, vol., no., pp.1-2, 5-9 Sept. 2011.

- [9] Yipsirimetee, T.; Kaewplung, P., "Optimal dispersion compensation and polarization-mode dispersion compensation in all-optical 40 Gbps-per-channel-based WDM wavelength-routed optical fibre networks," Wireless and Optical Communications Conference (WOCC), 2012 21st Annual, vol., no., pp.158-162, 19-21 April 2012
- [10] Manohari, R.G.; Sabapathi, T., "Analysis and reduction of polarization mode dispersion in an optical fibre," Recent Advancements in Electrical, Electronics and Control Engineering (ICONRAEeCE), 2011 International Conference on, vol., no., pp.438-441, 15-17 Dec. 2011.
- [11] Hamp, Michael J.; Wright, J.; Hubbard, M.; Brimacombe, B., "Investigation into the temperature dependence of chromatic dispersion in optical fibre," Photonics Technology Letters, IEEE, vol.14, no.11, pp.1524-1526, Nov. 2002.
- [12] Bobrovs, V.; Spolitis, S.; Ivanovs, G., "Comparison of chromatic dispersion compensation techniques for WDM-PON solution," Future Internet Communications (BCFIC), 2012 2nd Baltic Congress on, vol., no., pp.64-67, 25-27 April 2012.
- [13] Margaret Rouse, available online: <http://whatis.techtarget.com/definition/network-topology>, posted Jun. 2010, networking and communication, whatis.om, [accessed on] 17 Apr. 2014.
- [14] Cedric F. Lam, "Passive Optical Networks: Principles and Practice", Academic Press, vol., no., pp. 245-263, Oct. 2011.
- [15] Singh, S., "Performance Comparison of Optical Network Topologies in the Presence of Optimized Semiconductor Optical Amplifiers," Optical Communications and Networking, IEEE/OSA Journal of, vol.1, no.4, pp.313-323, September 2009.
- [16] Xin Miao; Xi Chen, "Research on Optical Fibre Transport Network Topology Optimization Supporting Smart Grid Core Services," Intelligent System Design and Engineering Application (ISDEA), 2010 International Conference on, vol.2, no., pp.232-235, 13-14 Oct. 2010.

- [17] Mitcsenkov, A.; Bakos, P.; Paksy, G.; Cinkler, T., "Technology-independent topology design heuristics for point-to-multipoint optical access networks," *Optical Network Design and Modeling (ONDM)*, 2013 17th International Conference on, vol., no., pp.298-303, 16-19 April 2013.
- [18] Nagatsu, Naohide; Watanabe, A.; Okamoto, S.; Sato, K., "Architectural analysis of multiple fibre ring networks employing optical paths," *Lightwave Technology, Journal of*, vol.15, no.10, pp.1794-1804, Oct 1997.
- [19] Eilam, T.; Moran, S.; Zaks, S., "Lightpath arrangement in survivable rings to minimize the switching cost," *Selected Areas in Communications, IEEE Journal on*, vol.20, no.1, pp.172-182, Jan 2002.
- [20] Turkcu, O.; Subramaniam, S., "Optimal Wavebanding in WDM Ring Networks," *Networking, IEEE/ACM Transactions on*, vol.22, no.1, pp.179-190, Feb. 2014.
- [21] Gerstel, O.; Ramaswami, R.; Sasaki, G.H., "Cost-effective traffic grooming in WDM rings," *Networking, IEEE/ACM Transactions on*, vol.8, no.5, pp.618-630, Oct 2000.
- [22] Delestre, C.; Ndo, G.; Labeau, F., "A binary tree network topology for statistical and physical PLC channel modeling," *Power Line Communications and Its Applications (ISPLC)*, 2013 17th IEEE International Symposium on, vol., no., pp.327-332, 24-27 March 2013.
- [23] Hongbin Wang; Wei Ding; Haiting Zhu, "A method of tree network topology inference based on hierarchical host table," *Systems and Informatics (ICSAI)*, 2012 International Conference on, vol., no., pp.1477-1481, 19-20 May 2012.
- [24] Hoerdtd, M.; Magoni, D., "Distribution of multicast tree states over the IPv6 network topology," *Communications*, 2004 IEEE International Conference on, vol.4, no., pp.1991-1995 Vol.4, 20-24 June 2004.

- [25] Sabolic, D.; Malaric, Roman; Bazant, A., "Some Properties of Impulse Response of Distribution Networks with Periodic Tree-Type Topology," Power Delivery, IEEE Transactions on, vol.26, no.4, pp.2416-2427, Oct. 2011.
- [26] Barranco, M.; Proenza, J.; Almeida, L., "Quantitative Comparison of the Error-Containment Capabilities of a Bus and a Star Topology in CAN Networks," Industrial Electronics, IEEE Transactions on, vol.58, no.3, pp.802-813, March 2011.
- [27] Arora, A.S.; Subramaniam, S.S.; Hyeong-Ah Choi, "Logical topology design for linear and ring optical networks," Selected Areas in Communications, IEEE Journal on, vol.20, no.1, pp.62-74, Jan 2002.
- [28] Panayiotou, T.; Ellinas, G.; Antoniadis, N., "Protection algorithms for groupcast sessions in transparent optical networks with mesh topologies," Optical Network Design and Modeling (ONDM), 2013 17th International Conference on, vol., no., pp.179-183, 16-19 April 2013.
- [29] Xiaojun Yu; Gaoxi Xiao; Tee-Hiang Cheng, "Dynamic multicast traffic grooming in optical WDM mesh networks: Lightpath versus light-tree," Optical Communications and Networking, IEEE/OSA Journal of, vol.5, no.8, pp.870-880, Aug. 2013.
- [30] Wojciech Kabacinski, "Nonblocking Electronic and Photonic Switching Fabrics", Springer, vol., no., pp. 1-2, Dec. 2005.
- [31] Radia Perlman, "Interconnections: Bridges, Routers, Switches, and Internetworking Protocols", Addison-Wesley professional computing series, Apc Series, Addison-Wesley Professional, vol., no., pp. 25-26, 2000.
- [32] <http://online-source.net/2011/12/19/hub-vs-switch-vs-router/>
- [33] June Jamrich Parsons, Dan Oja, "New Perspectives on Computer Concepts, Introductory", Available Titles Skills Assessment Manager (SAM) - Office 2007 Series, New Perspectives New perspectives series, Comprehensive, Cengage Learning, vol., ed. 11, pp. 261, Mar. 2008.

- [34] Dixit, A.; Lannoo, B.; Colle, D.; Pickavet, M.; Demeester, P., "Dynamic bandwidth allocation with optimal wavelength switching in TWDM-PONs," *Transparent Optical Networks (ICTON)*, 2013 15th International Conference on, vol., no., pp.1-4, 23-27 June 2013.
- [35] Koochi, S.; Shafaei, A.; Hessabi, S., "An Optical Wavelength Switching Architecture for a High-Performance Low-Power Photonic NoC," *Advanced Information Networking and Applications (WAINA)*, 2011 IEEE Workshops of International Conference on , vol., no., pp.1-6, 22-25 March 2011.
- [36] Weisheng Hu; Weiqiang Sun; Yaohui Jin; Wei Guo; Hao He; Lilin Yi, "Sub-wavelength switching for future Internet," *Transparent Optical Networks (ICTON)*, 2011 13th International Conference on , vol., no., pp.1-4, 26-30 June 2011.
- [37] Qirui Huang; Wen-De Zhong, "Wavelength-Routed Optical Multicast Packet Switch with Improved Performance," *Lightwave Technology, Journal of*, vol.27, no.24, pp.5657-5664, Dec.15, 2009.
- [38] Kitsuan, N.; Oki, E., "Performance of dynamic pump-wavelength selection for optical packet switch with chained parametric wavelength conversion," *Optical Communications and Networking, IEEE/OSA Journal of*, vol.6, no.2, pp.165-179, Feb. 2014.
- [39] Hamza, K.S.; Elbadawy, H.; Taha, I., "A novel Optical Packet Switch architecture with reduced wavelength conversion complexity," *High-Capacity Optical Networks and Enabling Technologies (HONET)*, 2009 6th International Symposium on, vol., no., pp.80-85, 28-30 Dec. 2009.
- [40] Lu Ruan, Dingzhu Du. "Optical Networks — Recent Advances: Recent Advances", of *Network Theory and Applications*, Springer, vol. 6, no., pp. 190-191, Sep. 2001.
- [41] Nikolettseas, José D.P. Rolim, "Theoretical Aspects of Distributed Computing in Sensor Networks", *Monographs in Theoretical Computer Science. An EATCS Series*, Springer, vol., no., pp. 260, Jan. 2011.

Chapter three

M-Arity Networks

3.1 Introduction

This chapter reports on the theory to allocate a wavelength in the tree networks coordinated arrangement in arity ordinal. Wavelength is the required metric to support all-to-all uni- multi- and broadcast in the network according to its depth, considering the fact that if the node is only a target, a source or target or is only and source at the same time. Equations are derived for one and two direction (downstream and upstream). Trade-off between wavelength cost and wavelength conversion cost considered therefore novel research concentrates on wavelength allocation without conversion. Moreover, node types have been taken in account with three cases.

All-optical network technology has the key for the current and future revolution in the communication. In the past few years, the wavelength-division –multiplexing (WDM) networks have been the strongest candidate for the future high requirement to provide enormous available network. Dense wavelength-division-multiplexing (DWDM) can provide a hundreds of channels (wavelengths) for each individual optical fibre. There are dual and simplex fibre cables.

The dual core system [1] allows data to be transferred in bi-directional, as opposed to simplex fibre cables, which typically only propagate data in one direction.

A dynamic routing and wavelength assignment (RWA) scheme in multi-fibre WDM networks with sparse wavelength conversion is proposed in [2]. Multicast in arity ordinal tree network has been introduced in [3].

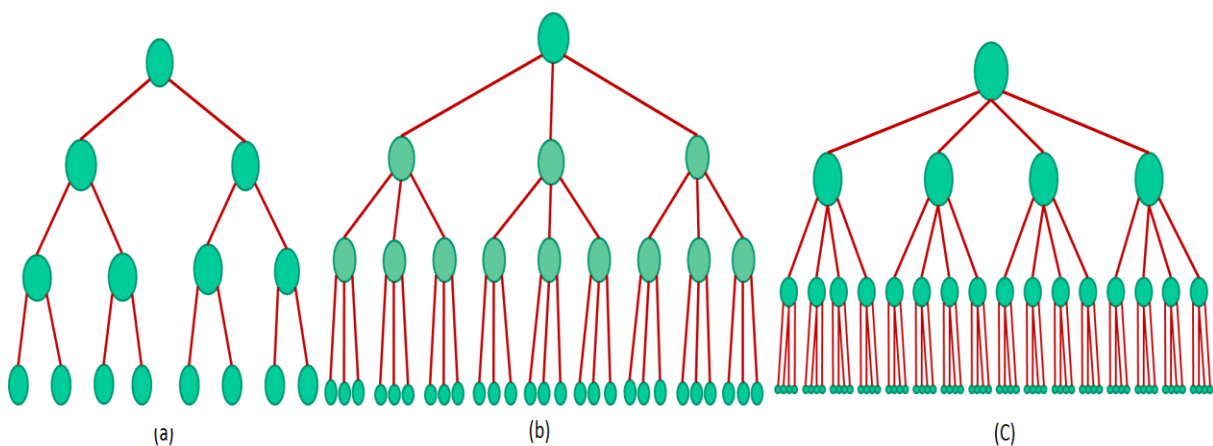

Figure 3- 1: Symmetric (Arity ordinal) tree networks (a) Binary (b) Ternary (c) Quaternary

This chapter designs and implements various algorithms for solving the static RWA problem with the objective of minimizing the maximum number of requested wavelengths based on LP relaxation formulations [4]. A novel wavelength assignment algorithm based on the method of optimal grouping of non-overlapping connections is proposed for a linear array network [5], while [6] presents a mathematical model for wavelength assignment to minimize number of wavelengths needed in wavelength reusable multi-carrier distributed (WRMD) wavelength-division-multiplexing (WDM) mesh networks. The problem of grooming sub-wavelength many-to-many traffic into high-bandwidth wavelength channels in optical wavelength division multiplexing (WDM) mesh networks is addressed in [7].

In [8] a naïve method of supporting functionality in a multicast-incapable (MI) environment is proposed by creating a virtual topology consisting of light-paths from the multicast source to each destination of the multicast session.



Figure 3- 2: N-node linear array network

3.2 Number of Wavelengths Calculation

Wavelengths are important parameter in any network. Each device can provide a specific number of call capacities depending on the available number of wavelengths. Thus the source, that supplies sixteen wavelengths, is better than other source that provides eight wavelengths. Device, that has more available wavelengths, is certainly more expensive but it has obviously less blocking probability, assuming the same load. However, the required number of wavelengths in any network has to be calculated in the first steps of the network design. Linear network [9] is investigated to find the equation of number of needed wavelengths for the data transmission researched to reach each individual destination node. In this work, they found equations for the required wavelength's number according to the nodes number in the network.

In this work [10], they have investigated the needed wavelengths in the ring network scenario. They have found formulas for the required wavelengths according to the number of nodes in ring network.

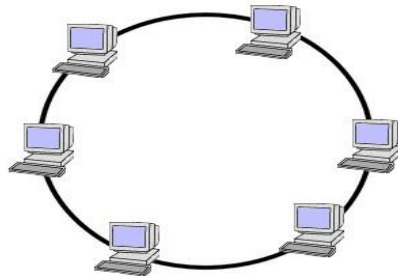

Figure 3- 3: Ring network

In this work [11], number of utilized wavelengths is reduced in the all-optical ring network. The array waveguide grating routers (AWGRs) [12] is used in all-to-all interconnections for N nodes to decrease number of utilized wavelengths.

3.3 Number of Nodes Formula

Nodes are main parts of any network which are connecting links with each other. They are called tree edges and they are directed from the root of the network toward the network leaves and they connect end-point (source) to end-point (destinations) [13]. It is an important object to calculate number of needed nodes and their job before network implementing and building. They are very useful in practical network operation; therefore, they investigated number of required nodes in an underwater network and they called them as signal sources [14]. According to the importance of the nodes number, the network structure is analysed and a mathematical model is developed to predict the number of nodes in a reordered binary decision diagram (ROBDD). This model is used to calculate the highest number of nodes which can be produced for a given number of variables [15]. Number of active nodes is investigated using network address translation (NAT). They have improved the network performance by investigating various aspects of schemes [16].

3.4 Tree network

There are various network topologies used in the optical fibre network such as tree, ring, mesh, bus. The tree network is chosen in this work because routing calculations are not required. In the mesh and ring network there is time consuming to find the

best route while in the tree network has one route to each destination and there is no need to waste time for routing. The other reason is the link stress which is distributed to all links in the tree while it is concentrated on the main link in the bus network. The disadvantage of the use of the tree network is that an error in any parent node will cause a breakdown in communication to all children and grandchildren nodes that pass through it.

3.5 Symmetric Tree Networks (Arity Tree Network)

The tree networks are investigated according to various schemes. Some of the works adopted symmetric tree networks (arity or m-ary networks) such as binary, ternary, quaternary ...etc. [17].

Number of Children	Name
1	Unary
2	Binary
3	Ternary
4	Quaternary
5	Quinary
6	Sedenary
7	Septenary
8	Octonary
9	Nonary
10	Denary
11	Undenary
12	Duodenary

Table 3- 1: M-ary numbering

Other works have implemented random tree networks in their researches [18-22]. A binary tree network is implemented to investigate its performance and improve it by increasing throughput and decreasing latency. They have also minimized packet losses [23]. They proposed an Optical-Network-on-Chip (ONoC) which significantly reduces the packet latency through simulations using a binary network. [24].

Tag-collision in radio frequency identification (RFID) system is investigated using a ternary tree network ($M=3$) [25]. The work in [26] proposes a broadcast encryption scheme with traitor tracing based on the ternary tree structure. They could reduce the number of labels stored in clients' devices and the length of the header by about

15% for the number of devices reach more than 65500 network devices. The ternary tree is implemented in this work to reduce the number of iterations and covers larger subgroup using broadcast messages than subgroup formed in binary tree based approaches [27]. The works [28-31] have adopted a ternary tree network and used it to be investigated in their research. Quaternary tree network is implemented and adopted in many research works [32-35].

3.6 Symmetric not random¹ networks

Tree networks can be symmetric when the parent nodes have specific number of children. When the parent node has two children, it is called binary network and when it has three children it is called ternary and if it has four children called quaternary ...etc. However, the random tree network does not have a specific number of children and thus some parent nodes have one child and some have two and some have three ...etc. the reasons behind choosing symmetric networks are:

- i. Networks' nodes, links, needed wavelengths are calculable, thus network engineering designers can easily find the required infrastructures. This facilitates the process of network building and implementation.
- ii. The parent nodes are balanced, that means the routers, switches and other devices in the whole network have the same load (even two, three, four or more destinations). Unlike the random tree networks, the switch devices do not have the same load, some of them has low load (one, two or three destinations) and some of them have high load (more than three destinations).
- iii. The network plan is clear if the area needs a small network (binary or ternary), or it needs a large network such as quaternary or bigger.
- iv. The links will be balanced and there are same calls per link. Unlike the random network where some links has low number of calls and other is full of calls.
- v. The data rate and signal power will be easily balanced if that required being same for all destinations.

¹By random we mean non symmetric

A network has number of paths (P_i) from all sources to all destinations and that what is called network capacity which is number of paths (P_i) in the network. Networks can be divided to three networks in this chapter.

1. Network with one source and just the leaf nodes are destinations and it is called one-to-many.
2. Network with one source and all other nodes are destinations and it can be called one-to-all.
3. Network with all are sources and destinations at the same time and that is called all-to-all.

3.6.1 One-to-Many

Network that has one source and only the leaf nodes (L) are destinations, where the number of destinations (D_i) equal to number of leaf nodes (L) and also equal to number of allocated wavelengths (A_w). To make calls from a source (root node) to all leaf nodes a number of wavelengths (A_w) is needed to carry these calls. If the height (h) between source (v) and destinations (D_i) are equal 1 that means root node (v) has number of children (m) equal to number of arity (A) of the network.

The networks which are to be studied here are arity ordinal (A) tree networks. That means when every parent node has the same number (m) of children, where $m > 1$. That calls also a perfect binary, ternary, quaternary ... etc.

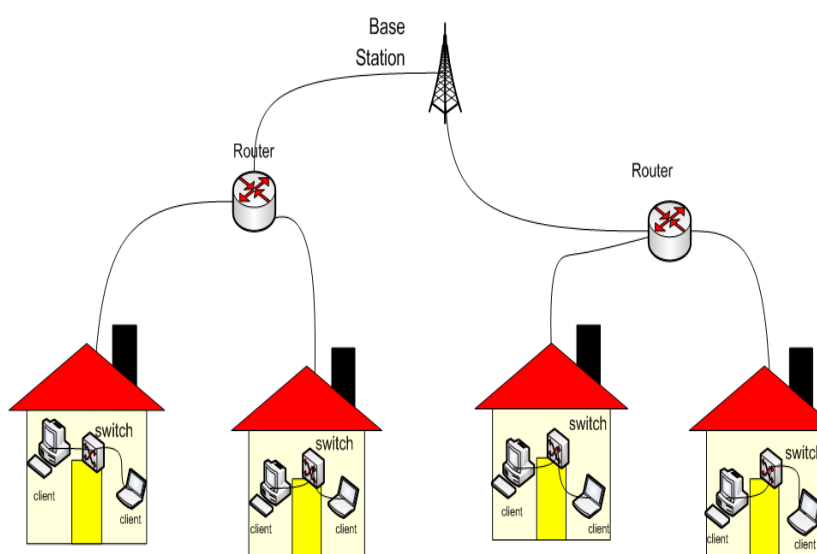

Figure 3- 4: One-to-many binary tree network

So, we need (A_w) wavelengths to send data to all (D_i), Therefore, ($A_w = D_i, A_w \in W$)

When (W) is all the candidate wavelengths in the network. If height (h) is increased to more than 1, the number of children will be increased and number of wavelengths has to be increased also.

- a. Binary tree ($A=2$) has height (h) and each parent has two children the leaf nodes will be found below, and we need wavelengths (A_w) to send data to all required destinations (D_i).

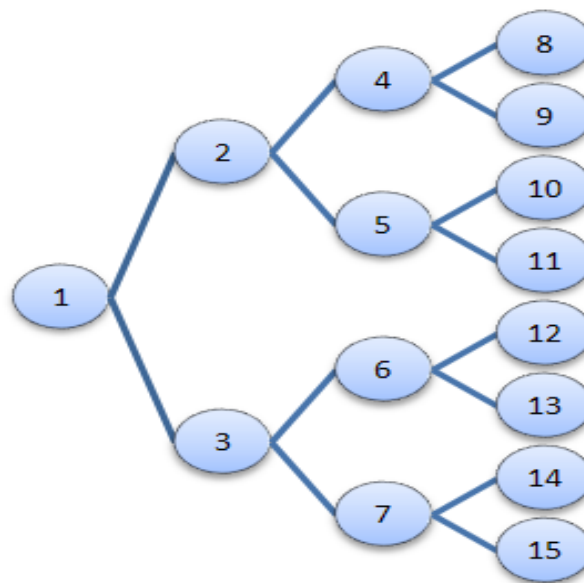

Figure 3- 5: Binary tree network

Height of tree (h_i)	Number of nodes (N_i)	Number of leaf nodes (L_i)	Number of destinations (D_i)	Number of paths (P_i)
height 1	3	2	2	2
height 2	7	4	4	4
height 3	15	8	8	8
height 4	31	16	16	16

Table 3- 2: Number of nodes, links, destinations and leaf nodes per each level in one-to-many binary tree network

While the arity is 2, we divide number of leaf nodes on the arity number (A).

$$2/2=1, 4/2= 2, 8/2=4, 16/2=8$$

As it is seen, results are 1, 2, 4, 8 and these are geometrical progression of the arity number 2.

Let n is a positive integer number and $n > 1$, to find the relationship between arity (A) of the tree, height (h) of the network and leaf nodes (L) number.

$$A * n = L \quad (3.1)$$

$$2 * n = 2 \rightarrow n = 1, 2 * n = 4 \rightarrow n = 2, 2 * n = 8 \rightarrow n = 4, 2 * n = 16 \rightarrow n = 8 \quad (3.2)$$

$$h_1: n = 2^0, h_2: n = 2^1, h_3: n = 2^2, h_4: n = 2^3 \dots h_h: n = 2^{h-1} \quad (3.3)$$

While the exponent of the arity is equal to the height number of the tree, so the equation (3.3) can be written.

$$h_h: n = 2^{h-1}$$

Insert n value in equation (3.2) to prove it.

$$h_1: 2 * 2^{1-1} = 2 \rightarrow 2^1 = 2, h_2: 2 * 2^{2-1} = 4 \rightarrow 2^2 = 4, h_3: 2 * 2^{3-1} = 8 \rightarrow 2^3 = 8, h_4: 2 * 2^{4-1} = 16 \rightarrow 2^4 = 16, h_i: 2 * 2^{h-1} = L \rightarrow 2^h = L$$

Hence,

$$\text{Leaf nodes}(L) = 2^h \quad (3.4)$$

While, $L = A_w$, so

Number of wavelengths needed to make a calls to all leaf nodes = Network capacity
(number of calls =

$$A_{w_i} = 2^h, \text{ where } i = h \text{ and } h \geq 1 \quad (3.5)$$

Number of nodes in the binary network according to the number of leaf nodes

$$N_i = (L * 2) - 1 \quad (3.6)$$

Number of nodes in the binary network according to the height,

$$N_i = 2^{i+1} - 1, \text{ where } i = h \text{ and } i \geq 0 \quad (3.7)$$

Also, Number of nodes in the binary network according to the number of leaf nodes is,

$$h_1: N_1 = L_1 + 1, \quad h_2: N_2 = L_2 + N_1, \quad h_3: N_3 = L_3 + N_2, \quad h_4: N_4 = L_4 + N_3, \\ h_i: N_i = L_i + N_{i-1} \quad (3.8)$$

If we compensate the value of N_i in the equation of N_{i+1} :

$$\begin{aligned} h_2: N_2 &= L_2 + L_1 + 1, h_3: N_3 = L_3 + L_2 + L_1 + 1, h_4: N_4 = L_4 + L_3 + L_2 + L_1 + 1, \\ h_i: N_i &= L_i \dots + L_3 + L_2 + L_1 + 1 \end{aligned} \quad (3.9)$$

Hence, Number of nodes in the binary network according to the number of leaf nodes:

$$N_i = \sum_{n=1}^i L_n + 1 \quad (3.10)$$

Number of nodes in the binary network according to the height is:

If we compensate eq. 3.4 in eq. 3.9,

$$h_2: N_2 = 2^2 + 2^1 + 2^0, h_3: N_3 = 2^3 + 2^2 + 2^1 + 2^0, h_4: N_4 = 2^4 + 2^3 + 2^2 + 2^1 + 2^0, h_i: N_i = 2^i + 2^4 + 2^3 + 2^2 + 2^1 + 2^0 \quad (3.11)$$

Hence,

$$N_i = \sum_{n=0}^i 2^n, \text{ where, } i \geq 0 \quad (3.12)$$

Hence, if we look to column two in table 3.2, we can find that the number of nodes is as shown below:

$$h_1: N_1 = 2^2 - 1, h_2: N_2 = 2^3 - 1, h_3: N_3 = 2^4 - 1, h_i: N_i = 2^{i+1} - 1$$

Hence, can be written as

$$N_i = 2^{i+1} - 1, \text{ where } i = h, i \geq 0 \quad (3.13)$$

Equations above are for a one direction data transmission. When the transmission assumed in two directions, equations have to be multiplied by 2.

- b. Ternary tree has arity of 3 ($A=3$) and each parent has three children. We have proved that the number of wavelengths (A_w) equal to number of destinations (D_i) and also equal to number of paths (network capacity). To find number of wavelengths (A_w) needed to feed all destinations (D_i), we could follow the same method above.

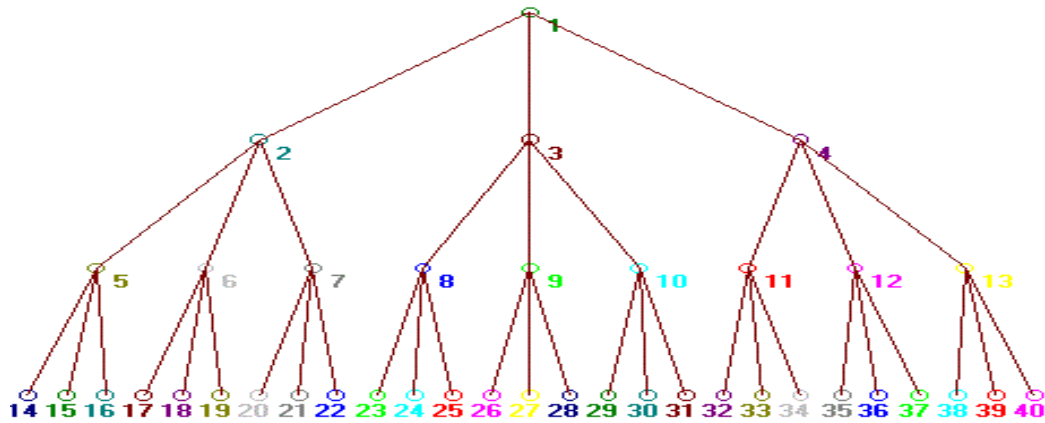

Figure 3- 6: Ternary tree

Height of tree (h_i)	Number of nodes (N_i)	Number of leaf nodes (L_i)	Number of destinations (D_i)	Number of paths (P_i)
height 1	4	3	3	3
height 2	13	9	9	9
height 3	40	27	27	27
height 4	121	81	81	81

Table 3- 3: Number of nodes, links, destinations and leaf nodes per each level in one-to-many ternary tree network

However, the arity is 3; we divide number of leaf nodes on the arity number (A).

$$3/3=1, 9/3= 3, 27/3=9, 81/3=27$$

As it is seen results are 1, 3, 9, 27 and these are geometrical progression of the arity number 3.

Let n is a positive integer number and $n > 1$, to find the relationship between arity (A) of the tree, height (h) of the network and leaf nodes (L) number.

$$A * n = L \tag{3.15}$$

$$3 * n = 3 \rightarrow n = 1, 3 * n = 9 \rightarrow n = 3, 3 * n = 27 \rightarrow n = 9, 3 * n = 81 \rightarrow n = 27 \tag{3.16}$$

As it is seen results of $n=1, 3, 9, 27$ and these are geometrical progression of the arity number 3.

$$h_1: n = 3^0, h_2: n = 3^1, h_3: n = 3^2, h_4: n = 3^3 \dots h_i: 3^{i-1}, h \geq 0 \tag{3.17}$$

While the exponent of the arity is equal to the height number of the tree, so the equation (3.17) can be written.

Height (h): $n=3^{h-1}$, insert n value in equation (3.16) to prove it.

$$h_1: 3 * 3^{1-1} = 3 \rightarrow 3^1 = 3$$

$$h_2: 3 * 3^{2-1} = 9 \rightarrow 3^2 = 9, h_3: 3 * 3^{3-1} = 27 \rightarrow 3^3 = 27, h_4: 3 * 3^{4-1} = 81 \rightarrow 3^4 = 81, h_4: 3 * 3^{h-1} = L \rightarrow 3^h = L$$

Hence,

$$\text{Leaf nodes } (L) = 3^h \quad (3.18)$$

Wherever we have proved that $L = A_w$, so

Number of wavelengths needed to make a calls to all leaf nodes = Network capacity
(number of calls) =

$$A_{w_i} = 3^h, \quad h \geq 0 \quad (3.19)$$

We can add N_0 to table (3.3) it can be the number of nodes in height 0 which is just one node, so $N_0 = 1$

Number of nodes in the ternary network according to the number of leaf nodes,

$$h_1: N_1 = L_1 + 1, \quad h_2: N_2 = L_2 + N_1, \quad h_3: N_3 = L_3 + N_2, \quad h_4: N_4 = L_4 + N_3, \\ h_i: N_i = L_i + N_{i-1} \quad (3.20)$$

If we compensate the value of (N_i) in the equation of (N_{i+1}) :

$$h_2: N_2 = L_2 + L_1 + 1, \quad h_3: N_3 = L_3 + L_2 + L_1 + 1, \quad h_4: N_4 = L_4 + L_3 + L_2 + L_1 + 1, \\ h_i: N_i = L_i + L_{i-1} + L_{i-2} + \dots + L_1 + 1 \quad (3.21)$$

Hence, Number of nodes in the ternary network according to the number of leaf nodes:

$$N_i = \sum_{n=1}^i L_n + 1 \quad (3.22)$$

Number of nodes in the ternary network according to the height,

If we compensate eq. 3.18 in eq. 3. 21,

$$h_2: N_2 = 3^2 + 3^1 + 1, h_3: N_3 = 3^3 + 3^2 + 3^1 + 1, \quad h_4: N_4 = 3^4 + 3^3 + 3^2 + 3^1 + 1, \\ h_i: N_i = 3^i + 3^{i-1} + 3^{i-2} + \dots + 3^1 + 1 \quad (3.23)$$

Hence,

$$N_i = \sum_{n=1}^i 3^n + 1, \quad \text{where,} \quad i \geq 0$$

$$h_2: N_2 = 3^2 + 3^1 + 3^0, \quad h_3: N_3 = 3^3 + 3^2 + 3^1 + 3^0, \quad h_4: N_4 = 3^4 + 3^3 + 3^2 + 3^1 + 3^0, \quad h_i: N_i = 3^i + 3^4 + 3^3 + 3^2 + 3^1 + 3^0$$

Hence,

$$N_i = \sum_{n=0}^i 3^n, \quad \text{where,} \quad i \geq 0 \quad (3.24)$$

Hence, if we look to column two in table.3, we can find that the number of nodes is as shown below:

$$h_1: N_1 = 3^2 - 1 = 8 \Rightarrow \frac{8}{2} = 4, \quad h_2: N_2 = 3^3 - 1 = 26 \Rightarrow \frac{26}{2} = 13, \quad h_3: N_3 = 3^4 - 1 = 80 \Rightarrow \frac{80}{2} = 40, \quad h_i: N_i = (3^{i+1} - 1) / 2$$

Hence, can be written as,

$$N_i = \frac{3^{i+1} - 1}{2}, \quad \text{where,} \quad i = h, \quad i \geq 0 \quad (3.25)$$

Equations above are for a one direction data transmission. When the transmission assumed in two directions, equations have to be multiplied by 2.

- c. Quaternary tree has arity of 4 ($A=4$) and each parent has four children. We have proved that the number of wavelengths (A_w) equal to number of destinations (D_i) and also equal to number of paths (network capacity). To find number of wavelengths (A_w) needed to feed all destinations (D_i), we could follow the same method above.

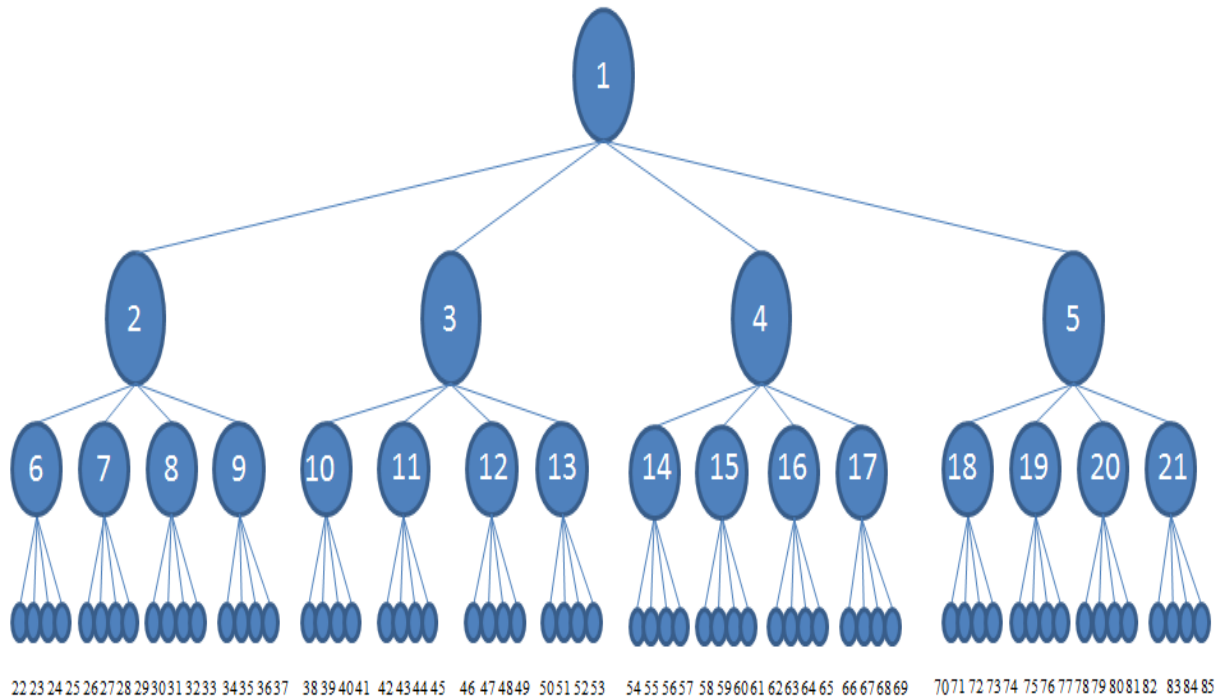

Figure 3- 7: Quaternary tree

Height of tree (h_i)	Number of nodes (N_i)	Number of leaf nodes (L_i)	Number of destinations (D_i)	Number of paths (P_i)
height 1	5	4	4	4
height 2	21	16	16	16
height 3	85	64	64	64
height 4	341	256	256	256

Table 3- 4: Number of nodes, links, destinations and leaf nodes per each level in one-to-many quaternary tree network

While the arity is 4, we divide number of leaf nodes (L_i) on the arity number (A).

$$4/4=1, 16/4= 4, 64/4=16, 256/4=64$$

As it is seen results are 1, 4, 16, 64 and these are geometrical progression of the arity number 4.

Let n is a positive integer number and $n > 1$, to find the relationship between arity (A) of the tree, height (h) of the network and leaf nodes (L) number.

$$A^n=L \tag{3.26}$$

$$4^n=4 \rightarrow n=1, 4^n=16 \rightarrow n=4, 4^n=64 \rightarrow n=16, 4^n=256 \rightarrow n=64 \tag{3.27}$$

As it is seen results of $n=1, 3, 9, 27$ and these are geometrical progression of the arity number 4.

$$h_1: n = 4^0, \quad h_2: n = 4^1, \quad h_3: n = 4^2, \quad h_4: n = 4^3 \dots h_i: 4^{i-1}, h \geq 0 \quad (3.28)$$

While the exponent of the arity is equal to the height number of the tree, so the equation (3.28) can be written.

Height (h): $n=3^{h-1}$, insert n value in equation (3.27) to prove it.

$$h_1: 4 * 4^{1-1} = 4 \rightarrow 4^1 = 4, \quad h_2: 4 * 4^{2-1} = 16 \rightarrow 4^2 = 16, \quad h_3: 4 * 4^{3-1} = 64 \rightarrow 4^3 = 64, \quad h_4: 4 * 4^{4-1} = 256 \rightarrow 4^4 = 256, \quad h_i: 4 * 4^{h-1} = L \rightarrow 4^h = L$$

Hence,

$$\text{Leaf nodes } (L) = 4^h \quad (3.29)$$

Wherever, we have proved that $L = A_w$, so

Number of wavelengths needed to make a calls to all leaf nodes =

$$\text{Network capacity (number of calls)} = A_{w_i} = 4^h, h \geq 0 \quad (3.30)$$

We can add N_0 to table 3.4 it can be the number of nodes in height 0 which is just one node, so $N_0 = 1$

Number of nodes in the quaternary network according to the number of leaf nodes,

$$h_1: N_1 = L_1 + 1, \quad h_2: N_2 = L_2 + N_1, \quad h_3: N_3 = L_3 + N_2, \quad h_4: N_4 = L_4 + N_3, \quad h_i: N_i = L_i + N_{i-1} \quad (3.31)$$

If we compensate the value of N_i in the equation of N_{i+1} :

$$h_2: N_2 = L_2 + L_1 + 1, \quad h_3: N_3 = L_3 + L_2 + L_1 + 1, \quad h_4: N_4 = L_4 + L_3 + L_2 + L_1 + 1, \quad h_i: N_i = L_i \dots + L_3 + L_2 + L_1 + 1 \quad (3.32)$$

Hence, Number of nodes in the quaternary network according to the number of leaf nodes:

$$N_i = \sum_{n=1}^i L_n + 1, \quad i \geq 0 \quad (3.33)$$

Number of nodes in the quaternary network according to the height,
 If we compensate eq. 3.29 in eq. 3.32,

$$h_2: N_2 = 4^2 + 4^1 + 4^0, \quad h_3: N_3 = 4^3 + 4^2 + 4^1 + 4^0, \quad h_4: N_4 = 4^4 + 4^3 + 4^2 + 4^1 + 4^0, \quad h_i: N_i = 4^i \dots + 4^4 + 4^3 + 4^2 + 4^1 + 4^0 \quad (3.34)$$

Hence,

$$N_i = \sum_{n=0}^i 4^n, \quad \text{where,} \quad i = h, \quad i \geq 0 \quad (3.35)$$

Hence, if we look to column two in table 3.4, we can find that the number of nodes is as shown below:

$$h_1: N_1 = 4^2 - 1 = 15 \Rightarrow \frac{15}{3} = 5, \quad h_2: N_2 = 4^3 - 1 = 63 \Rightarrow \frac{63}{3} = 21, \quad h_3: N_3 = 4^4 - 1 = 255 \Rightarrow \frac{255}{3} = 85, \quad h_i: N_i = (4^{i+1} - 1)/3$$

Hence, can be written as,

$$N_i = \frac{4^{i+1} - 1}{3}, \quad \text{where,} \quad i = h, \quad i \geq 0 \quad (3.36)$$

Equations above are for a one direction data transmission. When the transmission assumed in two directions, equations have to be multiplied by 2.

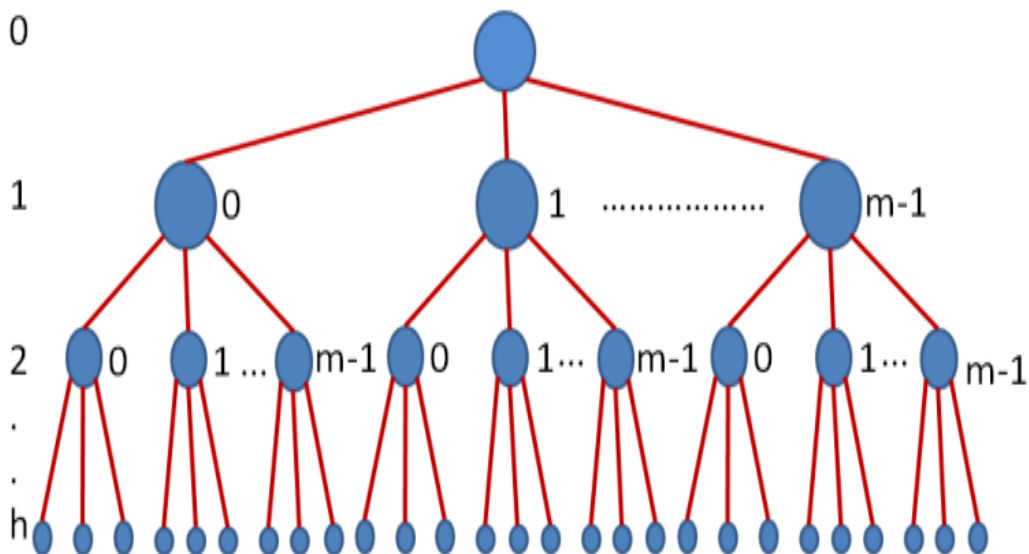

Figure 3- 8: M-arity network with height h

d. General equations for arity ordinal tree networks when the networks have one source and only the leaf nodes (L) are destinations are,

$$\text{Number of Leaf nodes } (L) = \text{Number of wavelengths } (A_{w_h}) = A^h, h \geq 1, A_w \in W \quad (3.37)$$

$$\text{Number of nodes } (N_h) = \sum_{n=1}^h L_n + 1, \quad h \geq 1 \quad (3.38)$$

$$\text{Number of nodes } (N_h) = \sum_{n=0}^h A^n, \quad h \geq 0 \quad (3.39)$$

$$\text{Number of nodes } (N_h) = \frac{A^{h+1} - 1}{A - 1}, \quad h \geq 0 \quad (3.40)$$

3.6.2 One-to-All

Network with one source and all other nodes are destinations (D_i), number of destinations (D_i) equal to number of nodes except the root node ($N_i - 1$) and naturally equal to number of allocated wavelengths (A_w) because each destination need one wavelength and not more. To make calls from a source (root node) to all nodes (destinations) need number of a wavelengths (A_w) to carry these calls. If the height (h) between source (v) and destinations (D_i) are equal 1, that means root node (v) has number of children (m) equal to arity of the network (A).

As we have mentioned, the networks to be studied here are arity ordinal (A). That means when every parent node has the same number (m) of children, where $m > 1$. That calls also a perfect binary, ternary, quaternary ... etc.

So we need (A_w) wavelengths to send data to all (D_i), Therefore, $A_w = D_i, A_w \in W$ When (W) is the number of all candidate wavelengths in the network. If height (h) is increased to more than 1, the number of children is increased and number of wavelengths has to be increased also.

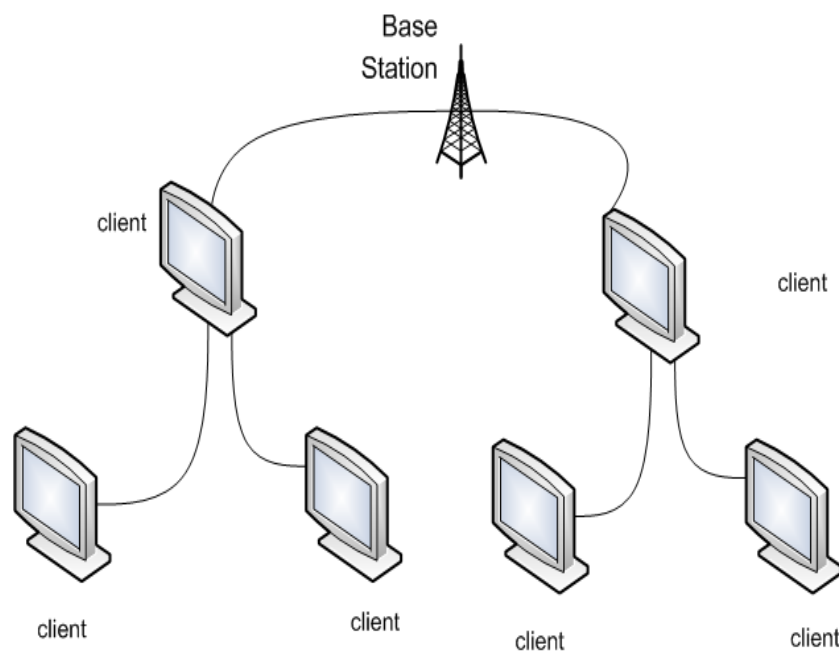

Figure 3- 9: One-to-many Binary tree network

- a. Binary tree ($A=2$) has height (h) and each parent has two children number of nodes (N_i) is found in eq. 3.10 and 3.14. We will find also number of wavelengths (A_w) to send data to all required destinations (D_i).

Height of tree (h_i)	Number of nodes (N_i)	Number of leaf nodes (L_i)	Number of destinations (D_i)	Number of paths (P_i)
height 1	3	2	2	2
height 2	7	4	6	6
height 3	15	8	14	14
height 4	31	16	30	30

Table 3- 5: Number of nodes, links, destinations and leaf nodes per each level in one-to-all binary tree network

As we can see in column 4 in table 3.5, number of destinations is represented in equation below:

$$h_1: D_1 = L_1, \quad h_2: D_2 = L_1 + L_2, \quad h_3: D_3 = L_1 + L_2 + L_3, \quad h_4: D_4 = L_1 + L_2 + L_3 + L_4, \\ h_i: D_i = L_1 + L_2 + L_3 + L_4 + \dots + L_i, \quad \text{where } i \geq 1 \quad (3.41)$$

Hence,

$$D_i = \sum_{n=1}^i L_n, \quad \text{where } i = h \text{ and } h \geq 1 \quad (3.42)$$

Compensate L_i by its value in eq. 3.4,

$$D_i = \sum_{n=1}^i 2^n, \quad \text{where } i = h \text{ and } h \geq 1 \quad (3.43)$$

While, $D_i = P_i = A_w = (N_i - 1)$, so number of wavelengths needed to feed all destinations is:

$$A_{w_i} = N_i - 1, \quad \text{where } i = h \text{ and } h \geq 1 \quad (3.44)$$

$$A_{w_i} = 2^{n+1} - 2, \quad \text{where } i = h \text{ and } h \geq 1 \quad (3.45)$$

We have proved also in eq. 3.10 and 3.13 the relationship between number of nodes in binary tree with number of leaf nodes and with height of the tree network.

Equations above are for a one direction data transmission. When the transmission assumed in two directions, equations have to be multiplied by 2.

- b. Ternary tree ($A=3$) has height (h) and each parent has three children, number of nodes (N_i) is found in. We will find also number of wavelengths (A_w) to send data to all required destinations (D_i).

Height of tree (h_i)	Number of nodes (N_i)	Number of leaf nodes (L_i)	Number of destinations (D_i)	Number of paths (P_i)
height 1	4	3	3	3
height 2	13	9	12	12
height 3	40	27	39	39
height 4	121	81	120	120

Table 3- 6: Number of nodes, links, destinations and leaf nodes per each level in one-to-all ternary tree network

As we can see in column 4 in table 3.6, number of destinations is represented in equation below:

$$\begin{aligned} h_1: D_1 &= L_1, \quad h_2: D_2 = L_1 + L_2, \quad h_3: D_3 = L_1 + L_2 + L_3, \quad h_4: D_4 = L_1 + L_2 + L_3 + L_4, \\ h_i: D_i &= L_1 + L_2 + L_3 + L_4 + \dots + L_i, \quad \text{where } i \geq 1 \end{aligned} \quad (3.46)$$

Hence,

$$D_i = \sum_{n=1}^i L_n, \quad \text{where } i = h \text{ and } h \geq 1 \quad (3.47)$$

Compensate L_i by its value in eq. 3.18,

$$D_i = \sum_{n=1}^i 3^n, \quad \text{where } i = h \text{ and } h \geq 1 \quad (3.48)$$

While, $D_i = P_i = A_w = (N_i - 1)$, so number of wavelengths needed to feed all destinations is:

$$A_{w_i} = N_i - 1, \quad \text{where } i = h \text{ and } h \geq 1 \quad (3.49)$$

$$A_{w_i} = \left[\frac{(3^{h+1} - 1)}{2} \right] - 1, \quad \text{where } i = h \text{ and } h \geq 1 \quad (3.50)$$

We have proved also in eq. 3.22 and 3.25 the relationship between number of nodes in binary tree with number of leaf nodes and with height of the tree network.

Equations above are for a one direction data transmission. When the transmission assumed in two directions, equations have to be multiplied by 2.

- c. Quaternary tree ($A=4$) has height (h) and each parent has four children, number of nodes (N_i) is found in. We will find also number of wavelengths (A_w) to send data to all required destinations (D_i).

Height of tree (h_i)	Number of nodes (N_i)	Number of leaf nodes (L_i)	Number of destinations (D_i)	Number of paths (P_i)
height 1	5	4	4	4
height 2	21	16	20	20
height 3	85	64	84	84
height 4	341	256	340	340

Table 3- 7: Number of nodes, links, destinations and leaf nodes per each level in one-to-all quaternary tree network

As we can see in column 4 in table 3.7, number of destinations is represented in equation below:

$$h_1: D_1 = L_1, \quad h_2: D_2 = L_1 + L_2, \quad h_3: D_3 = L_1 + L_2 + L_3, \quad h_4: D_4 = L_1 + L_2 + L_3 + L_4, \\ h_i: D_i = L_1 + L_2 + L_3 + L_4 + \dots L_i, \quad \text{where } i \geq 1$$

Hence,

$$D_i = \sum_{n=1}^i L_n, \quad \text{where } i = h \text{ and } h \geq 1 \quad (3.51)$$

Compensate L_i by its value in eq. 3.29,

$$D_i = \sum_{n=1}^i 4^n, \quad \text{where } i = h \text{ and } h \geq 1 \quad (3.52)$$

While, $D_i = P_i = A_w = (N_i - 1)$, so number of wavelengths needed to feed all destinations is:

$$A_{w_i} = N_i - 1, \text{ where } i = h \text{ and } h \geq 1 \quad (3.53)$$

$$A_{w_i} = \left[\frac{(4^{n+1} - 1)}{3} \right] - 1, \text{ where } , i = h \text{ and } h \geq 1 \quad (3.54)$$

We have proved also in eq. 3.33 and 3.36 the relationship between number of nodes in binary tree with number of leaf nodes and with height of the tree network.

Equations above are for a one direction data transmission. When the transmission assumed in two directions, equations have to be multiplied by 2.

d. General equations for arity ordinal tree networks when the networks have one source and all other nodes (\mathbf{D}_i) are destinations are,

$$\text{Number of wavelengths } (A_w) = \sum_{n=1}^h A^n, \quad h \geq 1, \quad A_w \in W \quad (3.55)$$

$$A_{w_h} = \left[\frac{(A^{h+1} - 1)}{A - 1} \right] - 1, \quad h \geq 1 \quad (3.56)$$

3.6.3 All-to-All

Network with all nodes are sources –except leaf nodes- and all are destinations (\mathbf{D}_i) –except root node- in the same time, number of destinations (\mathbf{D}_i) equal to number of nodes except the root node ($\mathbf{N}_i - 1$) and naturally equal to number of allocated wavelengths (\mathbf{A}_w) because each destination need one wavelength and not more. To make calls from the sources (\mathbf{N}_i) to all destinations (\mathbf{D}_i) need number of a wavelengths (\mathbf{A}_w) to carry these calls. If the height (h) for the tree is equal 1, that means root node (v) has number of children (m) equal to arity of the network (A).

As we have mentioned in 1 and 2, the networks to be studied here are arity ordinal (A). That mean when every parent node has the same number (m) of children, where $m > 1$. That calls also a perfect binary, ternary, quaternary ... etc.

So we need (\mathbf{A}_w) wavelengths to send data to all (\mathbf{D}_i), Therefore, $\mathbf{A}_w \neq \mathbf{D}_i, \mathbf{P}_i = \mathbf{A}_w, \mathbf{A}_w \in W$, because in this step the number of destinations has many paths and different candidate wavelengths to be connected depend on the height of the tree.

When (W) is the number of all candidate wavelengths in the network and height (h) is increased to more than 1, the number of paths is increased and number of wavelengths has to be increased also.

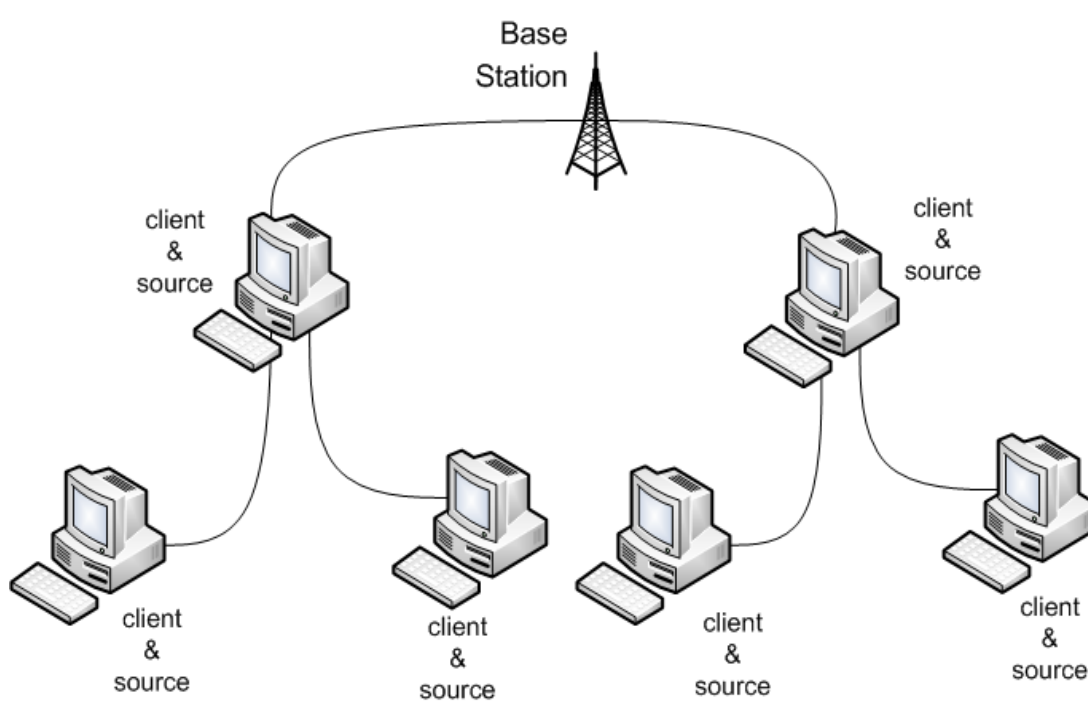

Figure 3- 10: All-to-all binary tree network

a. Binary tree ($A=2$) has height (h) and each parent has two children number of nodes (N_i) is found in eq. 3.10 and 3.13. We will find also number of wavelengths (A_w) to send data through different paths (P_i) to all required destinations (D_i).

Height of tree (h_i)	Number of nodes (N_i)	Number of leaf nodes (L_i)	Number of destinations (D_i)	Number of paths (P_i)
height 1	3	2	2	2
height 2	7	4	6	10
height 3	15	8	14	34
height 4	31	16	30	98

Table 3- 8: Number of nodes, links, destinations and leaf nodes per each level in all-to-all binary tree network

As we can see in column 5 in table 3.8, number of paths is represented in equation below:

$$h_1: P_1 = L_1, \quad h_2: P_2 = L_1 + 2L_2, \quad h_3: P_3 = L_1 + 2L_2 + 3L_3, \quad h_4: P_4 = L_1 + 2L_2 + 3L_3 + 4L_4, \quad h_i: D_i = L_1 + 2L_2 + 3L_3 + 4L_4 + \dots + iL_i, \text{ where } i \geq 1$$

Hence,

$$P_i = \sum_{n=1}^i nL_n, \quad \text{where, } \quad i = h \text{ and } h \geq 1 \quad (3.57)$$

Compensate L_i by its value in eq. 3.4,

$$P_i = \sum_{n=1}^i n2^n, \quad \text{where, } \quad i = h \text{ and } h \geq 1 \quad (3.58)$$

While, $P_i = A_w$, so number of wavelengths needed to feed all destinations is:

$$A_{w_i} = \sum_{n=1}^i n2^n, \quad \text{where, } \quad i = h \text{ and } h \geq 1 \quad (3.59)$$

$$h_1: (2^2) - m = P_1 \Rightarrow m = 2, \quad h_2: (2 * 2^3) - m = P_2 \Rightarrow m = 6, \quad h_3: (3 * 2^4) - m = P_3 \Rightarrow m = 14, \quad h_i: (i2^{i+1}) - m = P_i \Rightarrow m = D_i, \\ \text{while } D_i = 2^{n+1} - 2$$

Hence,

$$A_{w_n} = (n2^{n+1}) - (2^{n+1} - 2),$$

$$A_{w_n} = (n2^{n+1}) - 2^{n+1} + 2$$

$$A_{w_n} = (n - 1)2^{n+1} + 2, \quad \text{where } n = h \text{ and } h \geq 1 \quad (3.60)$$

We have proved also in eq. 3.10 and 3.13 the relationship between number of nodes in binary tree with number of leaf nodes and with height of the tree network.

Equations above are for a one direction data transmission. If the transmission assumed in two directions, equations have to be multiplied by 2.

- b. Ternary tree ($A=3$) has height (h) and each parent has two children number of nodes (N_i) is found in eq. 3.22 and 3.25. We will find also number of wavelengths (A_w) to send data through different paths (P_i) to all required destinations (D_i).

Height of tree (h_i)	Number of nodes (N_i)	Number of leaf nodes (L_i)	Number of destinations (D_i)	Number of paths (P_i)
height 1	4	3	3	3
height 2	13	9	12	21
height 3	40	27	39	102
height 4	121	81	120	426

Table 3- 9: Number of nodes, links, destinations and leaf nodes per each level in all-to-all ternary tree network

As we can see in column 5 in table 3.9, number of paths is represented in equation below:

$$h_1: P_1 = L_1, \quad h_2: P_2 = L_1 + 2L_2, \quad h_3: P_3 = L_1 + 2L_2 + 3L_3, \quad h_4: P_4 = L_1 + 2L_2 + 3L_3 + 4L_4, \quad h_i: D_i = L_1 + 2L_2 + 3L_3 + 4L_4 + \dots iL_i, \text{ where } i \geq 1$$

Hence,

$$P_i = \sum_{n=1}^i nL_n, \quad \text{where, } \quad i = h \text{ and } h \geq 1 \quad (3.61)$$

Compensate L_i by its value in eq. 3.18,

$$P_i = \sum_{n=1}^i n3^n, \quad \text{where, } \quad i = h \text{ and } h \geq 1 \quad (3.62)$$

While, $P_i = A_w$, so number of wavelengths needed to feed all destinations is:

$$A_{w_i} = \sum_{n=1}^i n3^n, \quad \text{where, } i = h \text{ and } h \geq 1 \quad (3.63)$$

$$h_1: (3^2) - m = P_1 \Rightarrow m = 3, \quad h_2: (2 * 3^3) - m = P_2 \Rightarrow m = 12, \quad h_3: (3 * 3^4) - m = P_3 \Rightarrow m = 39, \quad h_i: (i3^{i+1}) - m = P_i \Rightarrow m = k$$

$$h_1: \left(3^2 - \left[\frac{3^{2+1}-1}{2}\right] - 1\right) \div k = P_1 \Rightarrow k = 2, \quad h_2: \left((2 * 3^3) - \left[\frac{3^{2+1}-1}{2}\right] - 1\right) \div k = P_2 = > k = 2, \quad h_3: \left((3 * 3^4) - \left[\frac{3^{3+1}-1}{2}\right] - 1\right) \div k = P_3 \Rightarrow k = 2, \quad h_i: \left((i3^{i+1} - \left[\frac{3^{i+1}-1}{2}\right] - 1\right) \div k = P_i$$

while $k = 2$

Hence,

$$A_{w_n} = \frac{(n3^{n+1}) - \left(\frac{3^n - 1}{2}\right) - 1}{2}$$

$$A_{w_n} = \frac{(n3^{n+1}) - \left(\frac{3^n - 3}{2}\right)}{2}$$

$$A_{w_n} = \frac{\left(\frac{2n3^{n+1} - 3^n + 3}{2}\right)}{2}$$

$$A_{w_n} = \left(\frac{2n3^{n+1} - 3^n + 3}{4}\right)$$

$$A_{w_n} = \left(\frac{(2n - 1)3^n + 3}{4}\right), \quad \text{where } n = h, \quad h \geq 1 \quad (3.64)$$

We have proved also in eq. 3.22 and 3.25 the relationship between number of nodes in binary tree with number of leaf nodes and with height of the tree network.

Equations above are for a one direction data transmission. When the transmission assumed in two directions, equations have to be multiplied by 2.

- c. Quaternary tree ($A=4$) has height (h) and each parent has two children number of nodes (N_i) is found in eq. 3.33 and 3.36. We will find also number of wavelengths (A_w) to send data through different paths (P_i) to all required destinations (D_i).

Height of tree (h_i)	Number of nodes (N_i)	Number of leaf nodes (L_i)	Number of destinations (D_i)	Number of paths (P_i)
height 1	5	4	4	4
height 2	21	16	20	36
height 3	85	64	84	228
height 4	341	256	340	1252

Table 3- 10: Number of nodes, links, destinations and leaf nodes per each level in all-to-all quaternary tree network

As we can see in column 5 in table 3.10, number of paths is represented in equation below:

$$h_1: P_1 = L_1, \quad h_2: P_2 = L_1 + 2L_2, \quad h_3: P_3 = L_1 + 2L_2 + 3L_3, \quad h_4: P_4 = L_1 + 2L_2 + 3L_3 + 4L_4, \quad h_i: D_i = L_1 + 2L_2 + 3L_3 + 4L_4 + \dots iL_i, \text{ where } i \geq 1$$

Hence,

$$P_i = \sum_{n=1}^i nL_n, \quad \text{where, } \quad i = h \text{ and } h \geq 1 \quad (3.65)$$

Compensate L_i by its value in eq. 3.29,

$$P_i = \sum_{n=1}^i n4^n, \quad \text{where, } \quad i = h \text{ and } h \geq 1 \quad (3.66)$$

While, $P_i = A_w$, so number of wavelengths needed to feed all destinations is

$$A_{w_i} = \sum_{n=1}^i n4^n, \quad \text{where, } \quad i = h \text{ and } h \geq 1 \quad (3.67)$$

$$h_1: (4^2) - m = P_1 \Rightarrow m = 3, \quad h_2: (2 * 4^3) - m = P_2 \Rightarrow m = 12, \quad h_3: (3 * 4^4) - m = P_3 \Rightarrow m = 39, \quad h_i: (i4^{i+1}) - m = P_i \Rightarrow m = k$$

$$h_1: \left(4^2 - \left[\frac{4^{2+1}-1}{3}\right] - 1\right) \div k = P_1 \Rightarrow k = 3, \quad h_2: \left((2 * 4^3) - \left[\frac{4^{2+1}-1}{3}\right] - 1\right) \div k = P_2 = > k = 3, \quad h_3: \left((3 * 4^4) - \left[\frac{4^{3+1}-1}{3}\right] - 1\right) \div k = P_3 \Rightarrow k = 3, \quad h_i: \left((i4^{i+1} - \left[\frac{4^{i+1}-1}{3}\right] - 1\right) \div k = P_i$$

while $k = 3$

Hence,

$$A_{w_n} = \frac{(n4^{n+1}) - \left(\frac{4^n - 1}{3}\right) - 1}{3}$$

$$A_{w_n} = \frac{(n4^{n+1}) - \left(\frac{4^n - 4}{3}\right)}{3}$$

$$A_{w_n} = \frac{\left(\frac{3n4^{n+1} - 4^n + 4}{3}\right)}{3}$$

$$A_{w_n} = \left(\frac{3n4^{n+1} - 4^n + 4}{9}\right)$$

$$A_{w_n} = \left(\frac{(3n - 1)4^n + 4}{9}\right), \quad \text{where } n = h, \quad h \geq 1 \quad (3.68)$$

We have proved also in eq. 3.33 and 3.36 the relationship between number of nodes in binary tree with number of leaf nodes and with height of the tree network.

Equations above are for a one direction data transmission. When the transmission assumed in two directions, equations have to be multiplied by 2.

d. General equations for arity ordinal tree networks when the networks have all nodes as sources –except leaf nodes- and in the same time all are destinations (D_i) –except root node- ,

$$\text{Number of wavelengths } (A_{w_h}) = \sum_{n=1}^h nA^n, \quad h \geq 1, A_w \in W \quad (3.69)$$

$$\text{Number of wavelengths } (A_{w_h}) = \left(\frac{((A-1)h-1)A^{h+A}}{(A-1)^2}\right), \quad h \geq 1, A_w \in W \quad (3.70)$$

3.7 Summary

In this chapter, the symmetric (arity or m-Ary) networks have been proposed to be implemented instead of random networks. The number of required nodes, links, and wavelengths has been calculated by deriving their equations for different tree topologies and for the general symmetric tree networks. The reasons behind choosing the arity networks are mentioned and analysed.

There three situations of networks are investigated and described. The one-to-many case when there is just one source and just the leaves are destinations. The one-to-all case when there is just one source and all other nodes are destinations. The all-to-all case when all nodes are sources and destinations in the same time.

References

- [1] Kai Chang, "Fibre-Optic Communication Systems", A John Wiley & Sons, INC., USA, 2010.
- [2] Dewiani; Hirata, K.; Higami, Y.; Kobayashi, S.-Y., "Dynamic routing and wavelength assignment in multifiber WDM networks with sparse wavelength conversion," *ICT Convergence (ICTC), 2012 International Conference on*, vol., no., pp.567-572, 15-17 Oct. 2012.
- [3] Rafed Sabbar Abbas, Hamed Saffa Al-Raweshidy, "A New Centralized Multicast Wavelength Allocation Algorithm in Optical Fibre Network", *International Journal of Soft Computing and Software Engineering [JSCSE]*, Vol. 2, No. 11, pp. 13-19, Nov. 2012.
- [4] Christodouloupoulos, K.; Manousakis, K.; Varvarigos, E., "Comparison of Routing and Wavelength Assignment Algorithms in WDM Networks," *Global*

- Telecommunications Conference, IEEE GLOBECOM, IEEE*, vol., no., pp.1-6, Nov. 30 2008-Dec. 4 2008.
- [5] Sabrigiriraj, M.; Meenakshi, M.; Roopkumar, R., "Wavelength assignment in WDM linear array," *Electronics Letters*, vol.43, no.20, pp.1111-1113, September 27 2007.
- [6] Sitorus, B.; Kitsuwana, N.; Oki, E., "A mathematical model for wavelength assignment in multi-carrier distributed optical mesh networks," *Optical Internet (COIN), 2012 10th International Conference on*, vol., no., pp.20-21, 29-31 May 2012.
- [7] Saleh, M.A.; Kamal, A.E., "Approximation Algorithms for Many-to-Many Traffic Grooming in Optical WDM Networks," *Networking, IEEE/ACM Transactions on*, vol.20, no.5, pp.1527-1540, Oct. 2012.
- [8] Gadkar, Arush; Plante, Jeremy; Vokkarane, Vinod M.; "Multicast overlay for high-bandwidth applications over optical WDM networks," *Optical Communications and Networking, IEEE/OSA Journal of*, vol.4, no.8, pp.571-585, Aug. 2012.
- [9] Billah, A.R.B.; Bin Wang; Awwal, A. A S, "Effective traffic grooming in WDM rings," *Global Telecommunications Conference, 2002. GLOBECOM '02. IEEE*, vol.3, no., pp.2726-2730, 17-21 Nov. 2002.
- [10] Poulain, D.; Tomasik, J.; Weisser, M.; Barth, D., "Optimal receiver cost and wavelength number minimization in all-optical ring networks," *Telecommunications (ConTEL), Proceedings of the 2011 11th International Conference on*, vol., no., pp.411-418, 15-17 June 2011.
- [11] Yin, Yawei; Proietti, Roberto; Nitta, Christopher J.; Akella, Venkatesh; Mineo, Christopher; Yoo, S.J.B., "AWGR-based all-to-all optical interconnects using limited number of wavelengths," *Optical Interconnects Conference, 2013 IEEE*, vol., no., pp.47-48, 5-8 May 2013.
- [12] Rudy Guerra, Darlene R. Goldstein, "Meta-analysis and Combining Information in Genetics and Genomics", Chapman & Hall/CRC Mathematical and Computational Biology, CRC Press, vol., no., pp. 287, Dec.2010.
- [13] Anower, S.; Frater, M.R.; Ryan, M.J., "Estimation by cross-correlation of the number of nodes in underwater networks," *Telecommunication Networks and*

- Applications Conference (ATNAC), 2009 Australasian, vol., no., pp.1-6, 10-12 Nov. 2009.
- [14] Anower, S.; Frater, M.R.; Ryan, M.J., "Estimation by cross-correlation of the number of nodes in underwater networks," Telecommunication Networks and Applications Conference (ATNAC), 2009 Australasian, vol., no., pp.1-6, 10-12 Nov. 2009.
- [15] Tekeoglu, A.; Altiparmak, N.; Tosun, A.S., "Approximating the Number of Active Nodes Behind a NAT Device," Computer Communications and Networks (ICCCN), 2011 Proceedings of 20th International Conference on, vol., no., pp.1-7, Aug. 2011.
- [16] Eric McDaniel," Names of Bases (Octal, Hexadecimal, etc.)", available on: <http://mathforum.org/library/drmath/view/60405.html>, accessed on 15 May 2014.
- [17] Toldo, M.; Magli, E., "A resilient and low-delay P2P streaming system based on network coding with random multicast trees," Multimedia Signal Processing (MMSP), 2010 IEEE International Workshop on, vol., no., pp.400-405, 4-6 Oct. 2010.
- [18] Janson, T.; Mahlmann, P.; Schindelbauer, C., "A Self-Stabilizing Locality-Aware Peer-to-Peer Network Combining Random Networks, Search Trees, and DHTs," Parallel and Distributed Systems (ICPADS), 2010 IEEE 16th International Conference on, vol., no., pp.123-130, 8-10 Dec. 2010.
- [19] Hwa-Chun Lin; Sheng-Wei Wang, "Splitter placement in all-optical WDM networks," Global Telecommunications Conference, 2005. GLOBECOM '05. IEEE, vol.1, no., pp.5, 28 Nov.-2 Dec. 2005.
- [20] De, T.; Sen, S., "Multicast routing and wavelength assignment in sparse splitting all optical networks," Wireless and Optical Communications Networks, 2006 IFIP International Conference on, vol., no., pp.5, 2006.
- [21] Eira, A.; Pedro, J.; Pires, J., "Optimized design of multistage passive optical networks," Optical Communications and Networking, IEEE/OSA Journal of, vol.4, no.5, pp.402-411, May 2012.
- [22] Gumaste, A.; Mehta, S.; Vaishampayan, R.; Ghani, N., "Demonstration of Omnipresent Ethernet: A Novel Metro End-to-End Communication System

- Using Binary {+} Source Routing and Carrier Ethernet," *Lightwave Technology, Journal of*, vol.28, no.4, pp.596-607, Feb.15, 2010.
- [23] Binzhang Fu; Yinhe Han; Huawei Li; Xiaowei Li, "Accelerating Lightpath setup via broadcasting in binary-tree waveguide in Optical NoCs," *Design, Automation & Test in Europe Conference & Exhibition (DATE)*, 2010 , vol., no., pp.933,936, 8-12 March 2010.
- [24] Ching-Nung Yang; Yu-Ching Kun; Jyun-Yan He; Chih-Cheng Wu, "A practical implementation of ternary query tree for RFID tag anti-collision," *Information Theory and Information Security (ICITIS)*, 2010 IEEE International Conference on , vol., no., pp.283-286, 17-19 Dec. 2010.
- [25] Fukushima, K.; Kiyomoto, S.; Miyake, Y.; Sakurai, K., "Towards optimal revocation and tracing schemes The power of the ternary tree," *Security and Cryptography (SECURITY)*, 2011 Proceedings of the International Conference on , vol., no., pp.37-49, 18-21 July 2011.
- [26] Tripathi, Sachin; Biswas, G.P., "Design of efficient ternary-tree based group key agreement protocol for dynamic groups," *Communication Systems and Networks and Workshops*, 2009, COMSNETS 2009, First International, vol., no., pp.1-6, 5-10 Jan. 2009.
- [27] Werner, D.H.; Bretones, A.R.; Long, B. R., "Radiation characteristics of thin-wire ternary fractal trees," *Electronics Letters*, vol.35, no.8, pp.609-610, 15 Apr 1999.
- [28] Wei Wang; Jianfeng Ma; SangJae Moon, "Ternary Tree based Group Key Management in Dynamic Peer Networks," *Computational Intelligence and Security*, 2006 International Conference on , vol.2, no., pp.1265,1268, 3-6 Nov. 2006.
- [29] Gupta, A.K.; Wang, H., "On embedding ternary trees into Boolean hypercubes," *Parallel and Distributed Processing*, 1992. Proceedings of the Fourth IEEE Symposium on , vol., no., pp.230-235, 1-4 Dec 1992.
- [30] Yanushkevich, S.N.; Shmerko, V.P.; Stankovic, R.S.; Dziurzanski, P.; Popel, D.V., "Experimental verification of the entropy based method for minimization of switching functions on pseudo ternary decision trees," *Telecommunications in Modern Satellite, Cable and Broadcasting Services*, 1999. 4th International Conference on , vol.2, no., pp.452-459 vol.2, 1999.

- [31] Marston, R. E.; Shih, J. C., "Modified quaternary tree bucketing for Voronoi diagrams with multi-scale generators," Multiresolution Modelling and Analysis in Image Processing and Computer Vision, IEE Colloquium on, vol., no., pp.11/1-11/6, 21 Apr 1995.
- [32] Yang, O. W, "Two-centre tree topologies for metropolitan area networks," Communications, IEE Proceedings-, vol.141, no.4, pp.280-288, Aug 1994.
- [33] Mathew, S.K.; Krishnamurthy, R.K.; Anders, M.A.; Rios, R.; Mistry, K.R.; Soumyanath, K., "Sub-500-ps 64-b ALUs in 0.18- μ m SOI/bulk CMOS: design and scaling trends," Solid-State Circuits, IEEE Journal of, vol.36, no.11, pp.1636-1646, Nov 2001.
- [34] Al-Rabadi, A.; Perkowski, M., "Multiple-valued Galois field S/D trees for GFSOP minimization and their complexity," Multiple-Valued Logic, 2001. Proceedings. 31st IEEE International Symposium on, vol., no., pp.159-166, 2001.

Chapter Four

Wavelengths Multicast Switching

4.1 Introduction

There are two types of wavelengths switching that have been used in dynamic wavelength assignment (DWA) (unicast and multicast switching). The required wavelengths depend on the network traffic such as video conference, distance learning, HDTV, multimedia document distribution or just individual calls. A multicast switch [1] is multicast capable if it can replicate a packet from the incoming link on a particular wavelength to multiple outgoing links on the same wavelength. However, it was defined [2] as a technique to transmit information from a single source to multiple destinations. The multicast definition in [2] is more practical because it can multicast packets from the incoming link on a particular wavelength to multiple outgoing links on different wavelengths as it can be seen in our work in this chapter.

Next Generation Network (NGN) requires the interchanges between communications and broadcasting and many multimedia services and it attracts attentions because of that. The extremely large capacity of bandwidth to deliver video data is required for these multimedia services even though they are compressed [3]. Therefore, multicast technique is becoming a very necessary tendency to reduce bandwidth requirement due to various generated NGN services. International Telecommunications Union (ITU) develops multicast technical requirements [4] and a framework to support multicast capabilities for produced NGN services. In this case, the data will be sent to several destinations by using just a single wavelength. Therefore WDM capacity of served calls will be increased and the network will serve thousands of required data transmissions instead of hundreds.

The multicast technology has been investigated in many research works and been used to optimize its performance. Link load and path length has been minimized [5] to support large number of nodes in the network. They propose a new heuristic algorithm and it called power of node (PON), which improves the bandwidth and link delay of each node in the network. Power consumption was the main improvement [6] by implementing two types of multicast node architecture. One is with passive light splitter which requires wavelength continuity constraint. The other one contains

wavelength converters which do not need same wavelength along the path because of the wavelength conversion. The work [7] formulates two integer linear programming (ILP) models for the multicast technology (the separate and the joint ILP). The separate ILP processes one request each time in a sequential way while, the joint ILP processes all multicast requests together.

In this work, the method is implemented using Virtual Photonics Integrated (VPI) version 8.6. VPI software System is specified for optical experiments and they have three products. First one is the Transmission Maker Optical Systems which is used to get results for the work in this thesis. Second one is Component Maker Optical Amplifiers and the third one is the Component Maker Photonic Circuits.

Wave analyser in VPI software obtains the results for each converted wavelength individually. Therefore, the results have been collected one by one and exported to Microsoft Excel to draw the chart for all converted wavelengths. From these charts the results will be analysed and well explained.

The main devices have been used in this work are wavelengths converters specially the four-wave mixing (FWM), splitters (S), semiconductor optical amplifiers (SOA), laser diodes as a laser source, signal analyser and the optical fibres.

4.2 Wavelengths Splitter

A multicast wavelength needs light splitters [8] that split one light wave to more than one output. The output light may be in the same wavelength if there is no wavelength conversion or it will be in a different wavelength if there is a wavelength conversion. Light from an input fibre is collimated firstly [9], and then it is sent through the optic beam splitting. That is dividing light into several outputs. Both types of splitters one-to-many and two-to-many splitters [10] can be constructed in various ways with as many as eight or more outputs can reach 32 or 64 out-port. That can also be with both low return losses and low insertion losses.



Figure 4- 1: Optical fibre splitter one-to-four [10]

Splitters manufacturers determine the distributed ratio of the light between the outputs. Usually, the splitting ratio [11] can be 50%-50%, 90%-10%, 95%-5% and 99%-1%. For example, the using of 50%-50% splitter with 60 mW using one-to-two splitting, the output will be 30 mW to the both outputs. However, any value of light distribution ratio can be achieved if customers need it. The ratio can be in dB also.

4.3 Wavelengths Conversion (WC)

To understand the work in this chapter, many topics have to be well analysed. Wavelength conversion is one of them. It can be defined [12] as the change of an input wavelength to a different output wavelength without loss of any data carried on the incoming wavelength. The device which makes this process is called wavelength converter. The reason behind using wavelength conversion is to overcome the blocking probability caused by the wavelength use in the other link of its path. Wavelength conversion can convert an incoming wavelength by changing it to another available wavelength. The optical transmitter (1) is sending data to Kent using wavelength (λ_1) and sending other data to London using wavelength (λ_2). In this case, if the optical transmitter (2) wants to send data to London using wavelength (λ_2), the switch has to convert incoming (λ_2) to (λ_1) because wavelength (λ_2) is already busy from the switch to London.

In this situation, the call coming from transmitter (2) will be blocked if there is no wavelengths conversion in the switch infrastructure. This is the main advantage of the wavelength conversion which is reducing number of blocked calls.

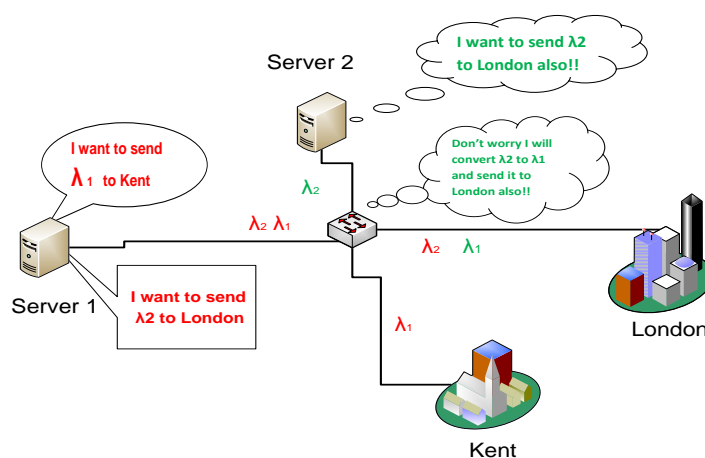

Figure 4- 2: Wavelengths conversion

4.3.1 Wavelengths Conversion Degree (WCD)

There are various types of converters and wavelength converters. The wavelength converters can be sorted out to different degrees. The full degree converters [13] can convert ingoing wavelength to any outgoing wavelength. In this case the degree (d) of the converter is equal to the number of wavelengths ($W-1$) in the network. However there are converters that have limited degree of conversion [14]. When the ingoing wavelength can be converted to just one other outgoing wavelength that means $d=1$, and when the converter can convert the input wavelength to only two output wavelengths that means $d=2$. However, there is no conversion in the node when $d=0$ and that device has no wavelength conversion capability. The wavelength conversion degree is costly and it affects the expense of the converter. The converter device, which has a higher conversion degree, is surely more expensive and complex than the converter device that has lower conversion degree.

4.3.2 Wavelength Conversion Availability (WCA)

In any optical network, the nodes may have wavelength conversion availability or not. In the case where all nodes in a network have this capability that is called full wavelength conversion [15]. While in other networks, if the some nodes have wavelength conversion ability and some have not, this is called a sparse wavelength conversion. Many research works have mixed types of conversion degrees and wavelength conversion tendency. This is required to minimize cost using sparse scheme [16] or to reduce blocking probability [17] or even to decrease time delay caused by conversion [18]. The wavelength converters (WC) are very expensive and they have also implementation complexity. Therefore, minimizing number of WC is reducing network cost and its building complexity. However that will lead to an increase in blocking probability and this is the trade-off between cost and blocking in any network.

4.3.3 Conversion Techniques

Due to the high importance of using wavelength conversion in optical networks, there are different techniques that have been proposed and investigated. Mainly, the semiconductor optical amplifier (SOA) is used in the most methods to get a better quality of the converted wavelengths. Four-wave mixing (FWM) in semiconductor optical amplifier is the technique that is using the frequency mixing by pumping a

new frequency with the input one. The pumped wave has to be much stronger than the probe one [19]. The concept of FWM in SOA has been utilized to convert wavelengths with up to 50 Gbps [20]. While [21] demonstrates an 112Gbps using FWM scheme. The outgoing wavelength from the FWM is (λ_{out}) and ingoing wavelength is (λ_{in}), the pumping continuous wave (CW) has to be (λ_{pump}). Where $\lambda_{out} = \lambda + \alpha$, $\lambda_{in} = \lambda - \alpha$ and $\lambda_{pump} = \lambda$

$$\lambda_{out} = 2\lambda_{pump} - \lambda_{in} \tag{4.1}$$

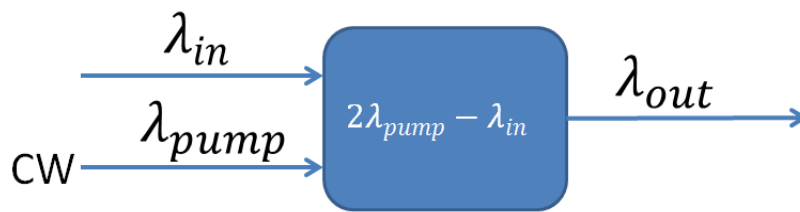

(a)

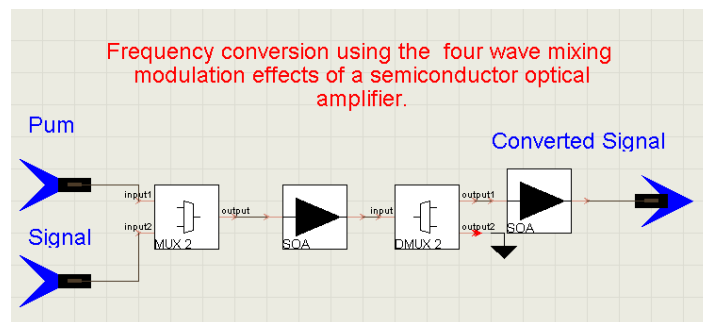

(b)

Figure 4- 3: Four wave mixing technique (a) outside, (b) inside

FWM technique is used in SOA. After mixing frequencies, they are launched into SOA but there is another technique which uses a semiconductor ring laser (SRL). The results [22] showed that using SRL is better in performance and it requires lower power and experiences less cross-talk.

The other conversion technique is cross modulation which is using an active semiconductor optical device like SOA and lasers. It has two modes: cross gain mode (XGM) and cross phase mode (XPM). XGM is always inverting the input wavelength in the output [23], unlike XPM which may invert or not the ingoing wavelength. The XPM in SOA proposed using nonlinear optical loop mirror (NOLM)

and Mach-Zender interferometer (MZI). The XGM is simple and easy to configure wavelength conversion. XGM has high conversion efficiency (η) which is formulated in Eq.4.2 and it has also a high bit rate up to 40 Gbps [24].

$$\eta = 10 \log \frac{P_{out}}{P_{in}} \quad (4.2)$$

Despite these benefits of XGM wavelength conversion, there are many disadvantages such as the huge needed power to feed semiconductor optical amplifier (SOA). XGM also suffers from a large noise figure (NF) which is defined in Eq.4.3.

$$NF = 10 \log \frac{SNR_{in}}{SNR_{out}} \quad (4.3)$$

Where, SNR_{in} and SNR_{out} are signal to noise ratio for input and output wavelengths respectively.

To overcome the disadvantages of the XGM, the cross phase mode (XPM) scheme may be used by utilizing more SOAs in its configuration [25]. Furthermore, XPM and XGM do not provide a good transparency and quality of received bit rate and also modulation performance. FWM scheme can be utilized to convert wavelengths to vanquish the disadvantages of XGM and XPM schemes. However, FWM wavelength conversion using nonlinearity of the semiconductor optical amplifier (SOA) is been the significantly favoured methodology in the most networks because of its advantages. FWM serves a good transparency and quality of received bit rate and also modulation performance unlike XGM and XPM methods. Moreover, FWM protects and safeguards the phase and amplitude of information carried by the converted wavelength. That is because FWM does not change the optical characteristics in the converted wavelength when the conversion using SOA has taken place. The main feature of the FWM technique is the high bit rate quality and quantity which reaches up to tens of gigabits, whilst being simple to implement and having low dispersion. [26]

4.3.4 Wavelength Conversion Range (WCR)

Conversion range is the difference between the input and output wavelengths of the wavelength converter (WC) device as defined by Eq.4.4. The WCR could be in a

very short range (0.1 nm) or may be in a very high range (315 nm). In [27] an ultra-wideband range was converted from 1625 nm to 1310 nm and vice versa.

$$WCR = \lambda_{out} - \lambda_{in} \quad (4.4)$$

The conversion range has been divided into up-conversion (from long to short wavelength) and down-conversion (from short to long wavelength). In a specific case, cross-phase modulation (XPM) technology is extremely beneficial for wideband wavelength conversion. Research work has demonstrated that a wide wavelength range from 1300 to 1550 nm can be converted using a single 1.3 μm SOA [28].

Up-conversion using cross gain modulation has better performance than down-conversion [29]. As a result of the significant effect of the conversion range on the performance of the converted wavelength, it has to be thoroughly investigated in any work utilizing wavelength conversion.

The work in this chapter, investigates the wavelength conversion range which has to be taken in account due to its effect on the signal power and conversion time delay. FWM has been used [30] to convert wavelengths with range of 100.2 nm with a data rate of 40 Gbps. However other researches work [31] achieved ultra-wide conversion range with 200 nm from 1300 nm to 1500 nm. That has been achieved by using designed nonlinear dispersion-shifted fibre (DSF) pumped by a CW 1399 nm using power of 310 mW.

4.3.4.1 Group Delay (GD)

In the work presented in this chapter, there are several topics that have to be explained and defined. One of these topics is Group Delay (GD) which is defined [32] as the delay of the input wavelength passed through a device or it is the negative slope of the phase response. GD has been defined mathematically by the rate of change of the total phase shift with respect to the angular frequency as shown in Eq. 4.5. It is measured by time unit and it is affected by the phase and frequency differences. It is denoted usually by (τ_g) but we refer to it as (GD) for it in this work.

$$GD = -\frac{d\phi}{d\omega} \tag{4.5}$$

Where,

$(d\phi)$ is difference in phase

$(d\omega)$ is difference in angular frequency

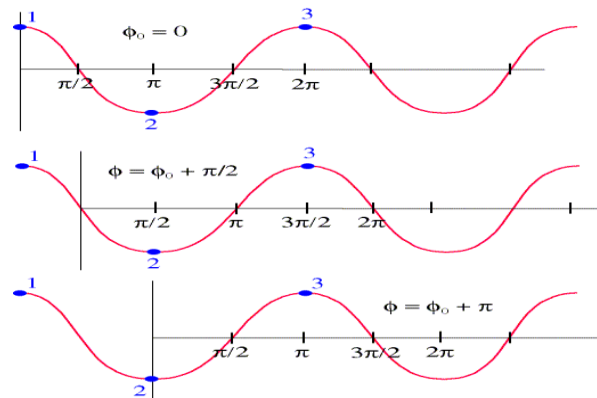

Figure 4- 4: Phase changing

The lag and lead terms are important to know the phase status of the two or more waves. Wave one lags wave two means that wave one is behind wave two by a specific value. While, if wave one leads wave two, that means wave one ahead of the wave two by a particular value.

It appears from the figure above how the phase can be varied from one wavelength to another. The first wave is leading the second wave by $\pi/2$ and the phase difference is $\pi/2$ if the second wave is the input and the first wave is the output. While, the phase difference is $-\pi/2$ when the first wave is the input and the second wave is the output. The phase change can be wider such as the difference between first and third waves. The third wave is lagging the first wave by π , so the phase change is π .

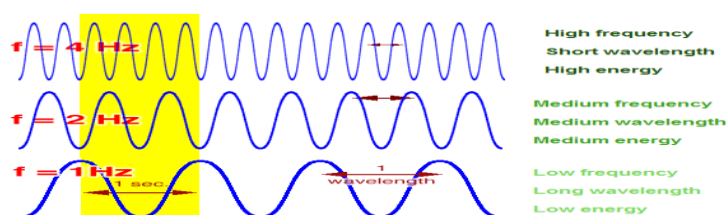

Figure 4- 5: Frequency difference

Waves have different cycles in a second. If it completes a cycle in a second that called one hertz (1 Hz) such as the third wave, while, if it completes a cycle in a half second that means it has a frequency of two hertz (2 Hz). So, the frequency difference between first and second waves is 2 Hz. However, it can be larger such as the difference between first and third waves which is 3 Hz. What we need in this topic is to calculate GD which is the angular frequency (ω). It is measured in radians (rad) which is the angle that equal to the length of a corresponding arc of the unit circle [33].

The relationship between ordinary frequency (f) and angular frequency (ω) is shown in Eq. 4.8.

$$f = \frac{1}{T} \quad 4.6$$

$$\text{and } \omega = \frac{2\pi}{T} \quad 4.7$$

Therefore,

$$\omega = 2\pi f \quad 4.8$$

Where,

(T) is the time period of one complete wave measured by second

(f) is the ordinary frequency for one cycle measured by Hz

(ω) is the angular frequency for one whole wave measured by rad

According to the angular frequency equation (4.8), if the third wave in figure 4.5 has angular frequency of $2\pi \text{ rad}$, then the first wave has angular frequency of $8\pi \text{ rad}$. Therefore, the angular frequency difference is $6\pi \text{ rad}$ between first and third waves. However, it is just $3\pi \text{ rad}$ between second and third waves. Now, it is clear to find phase and angular frequency which can be used to find GD.

The GD has been investigated and experimented to find the effect of the WCR on it. To find the effect of WCR, there is a software implementation that has been built to find the value of the GD in the long and short WCR. The preferred wavelength band

in optical fibres is centralised on 1300 nm [34], because of its low attenuation and low losses. Therefore, the conversion range is set to convert wavelength from different values to 1300 nm. Another reason behind choosing this conversion method is to measure the GD with the same effect of the dispersion, because dispersion is affecting the group delay and at the same time the dispersion is affected by different frequencies.

4.3.4.2 Signal's Power

Each wave has a specific value of power affected by various parameters such as input power, injected power, length of transmission, number of devices that the wave come through, number of processes in each device...etc. Wave power is needed to be analysed in this chapter because it is affected by the wavelength conversion range (WCR).

In telecommunication, decibel (dB) unit is used for measuring signal power. It has been proposed by Bell Telephone Laboratories and it was convenient for telephone engineering in the 1920s [35]. This unit has been very popular in communication engineering to calculate the signal attenuation at each distance unit such as mile, kilometre...etc. It is used to minimize numbers of zeroes, so instead of writing 100 W it will be 20 dB and instead of writing 1000 W it will be 30 dB...etc. The second advantage of dB is that the multiplication operation is simplified to an addition operation.

The gain of the power, losses in optical fibre or signal to noise ratio (SNR) is always measured by dB or dBm. How that is calculated, is defined in the following Eq. 4.9. The unit decibel (dB) which is ten times logarithm based on ten of the output power to the input power, is one tenth of bel (B) but telecommunication engineering prefers using dB instead of B because of the small amount of the measured power in this area.

$$G_{dB} = 10 \log_{10} \frac{P_{out}}{P_{in}} \quad 4.9$$

Where, (G_{dB}) is power gain in decibel

(P_{out}) is the output power in watt

(P_{in}) is the input power in watt

The power in the microwave, radio or optical network is measured by dBm, which is relative to the power measured in (mW) instead of using dBW which mention to the power measured in watt (W). However, dBW is always 30 more than dBm because if 1 mW = 0.001 W the decibel power will be 0 dBm which is equal to -30 dBW. Therefore, power in dBm is found in Eq. 4.10.

$$P_{dBm} = 10 \log_{10} \frac{P}{1 \text{ mW}} = 30 + P_{dBW} \quad 4.10$$

where,

(P_{dBm}) power in decibel for power in milliwatt

(P_{dBW}) power in decibel for power in watt

4.3.4.3 Various Conversion Ranges

Wavelength conversion is very important topic in wavelength switching in optical fibre networks. It has a significant effect on power consumption, delay and even quality of service (QoS). In this section, the output wave power is investigated and there are different tests to identify the effect of the WCR on the converted wavelengths.

WCR is experimented for various ranges starting from 250 nm with ultra-wide band conversion availability to 10 nm with narrow band conversion availability. The conversion range has been set to be converted from different wavelengths to 1300 nm. Wavelength with value 1300 nm has been chosen because of its low attenuation, dispersion and losses.

Moreover, it has high energy level because energy is inversely proportional with the wavelength and directly proportional with the frequency of any wave as shown in equation 4.13.

$$f = \frac{c}{\lambda} \quad 4.11$$

$$\text{and } f = \frac{E}{h} \tag{4.12}$$

$$\text{then, } E = \frac{hc}{\lambda} \tag{4.13}$$

where,

(c) is speed of light

(f) is frequency

(λ) is wavelength

(h) is Planck's constant ($6.62606896(33) \times 10^{-34} \text{ J s} = 4.13566733(10) \times 10^{-15} \text{ eV}$)

The four-wave mixing conversion method has been adopted in this work because of its QoS and it is illustrated as shown in figure 4.6.

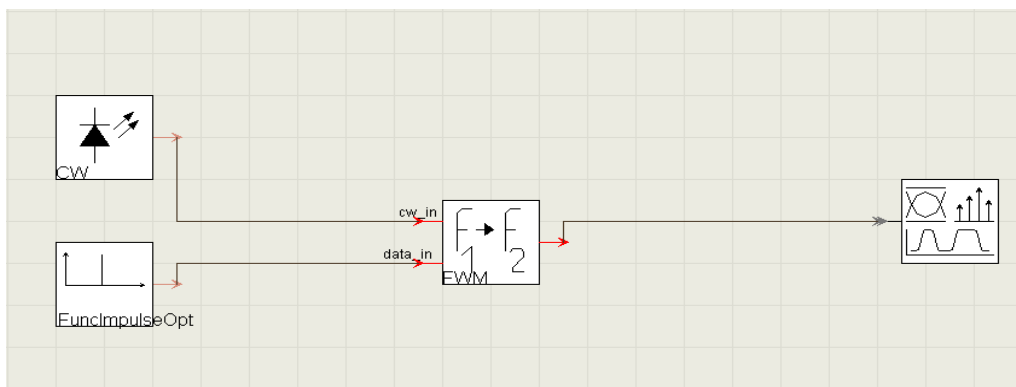

Figure 4- 6: Four-wave mixing converter in VPI

It consists of a continuous wave connected to a semiconductor optical amplifier (SOA), input data which is represent the input wavelength, the SOA as a converter to obtain the new converted wavelength at the output and finally a signal analyser to analyse the characteristic of the converted wavelength. The input data has been set as a pulse to be clear at the output and to be easily distinguished throughout the outgoing continuous wave.

To examine the effect of the WCR on the converted wavelengths power, the module has been set as shown in table 4.1.

Continuous Wave (CW) Pump Wave	
Emission Frequency	212.159-229.889 THz
Wavelength	1414-1304.98 nm
Power	1 mW
Line Width	1 MHz
Input Wavelength	
Pulse Frequency	193.548-229.008 THz
Wavelength	1550-1310 nm
Peak Power	1 W
Semiconductor Optical Amplifier (SOA)	
Channel Spacing	100 GHz
Bandwidth	25 THz
Pump Frequency	212.159-229.889 THz
Input Frequency	193.548-229.008 THz
Output Frequency	230.7692 THz
Insertion Loss	0.0 dB

Table 4- 1: Wavelengths Conversion Setup

To find the effect of the WCR on the wave power and group delay, wavelength conversion has been performed with different wavelengths to wavelength with value 1300 nm. The conversion setup has been varied twenty five times by decreasing WCR by ten nm each step.

The converted wavelength powers are sketched and line chart type is used as shown in figure 4.7. Moreover, VPI software uses frequencies instead of wavelengths. Therefore, wavelengths have been converted to frequencies just to set them up in the software and obtain the results. Wavelengths are converted by using the formula 4.14 which is linking frequency, wavelength and light speed.

$$f = \frac{C}{\lambda} \tag{4.14}$$

(f) is the wave frequency

(C) is the light speed

(λ) is the wavelength

The input, pump and output wavelengths have been converted to frequencies and set up in the FWM converter in VPI to get obtain for each conversion following the table 4.2 below. The wavelengths conversion used the preferred wave bands in optical fibres which lie between 1300 nm and 1550 nm.

Conversion Range	Input Wavelength	Input Frequency	Pump Frequency	Pump Wavelength
250	1550	193.5483871	212.1587935	1414.03519
240	1540	194.8051948	212.7871974	1409.859257
230	1530	196.0784314	213.4238157	1405.653812
220	1520	197.3684211	214.0688105	1401.41854
210	1510	198.6754967	214.7223483	1397.153125
200	1500	200	215.3846	1392.857242
190	1490	201.3422819	216.0557409	1388.530565
180	1480	202.7027027	216.7359514	1384.17276
170	1470	204.0816327	217.4254163	1379.783491

160	1460	205.4794521	218.124326	1375.362416
150	1450	206.8965517	218.8328759	1370.909187
140	1440	208.3333333	219.5512667	1366.423453
130	1430	209.7902098	220.2797049	1361.904857
120	1420	211.2676056	221.0184028	1357.353036
110	1410	212.7659574	221.7675787	1352.767622
100	1400	214.2857143	222.5274571	1348.148241
90	1390	215.8273381	223.2982691	1343.494516
80	1380	217.3913043	224.0802522	1338.806062
70	1370	218.9781022	224.8736511	1334.082488
60	1360	220.5882353	225.6787176	1329.323399
50	1350	222.2222222	226.4957111	1324.528392
40	1340	223.880597	227.3248985	1319.697059
30	1330	225.5639098	228.1665549	1314.828986
20	1320	227.2727273	229.0209636	1309.923752
10	1310	229.0076336	229.8884168	1304.98093
	1300	230.7692308	230.7692154	

Table 4- 2: Input and pump wavelengths to frequencies in the wavelengths conversion

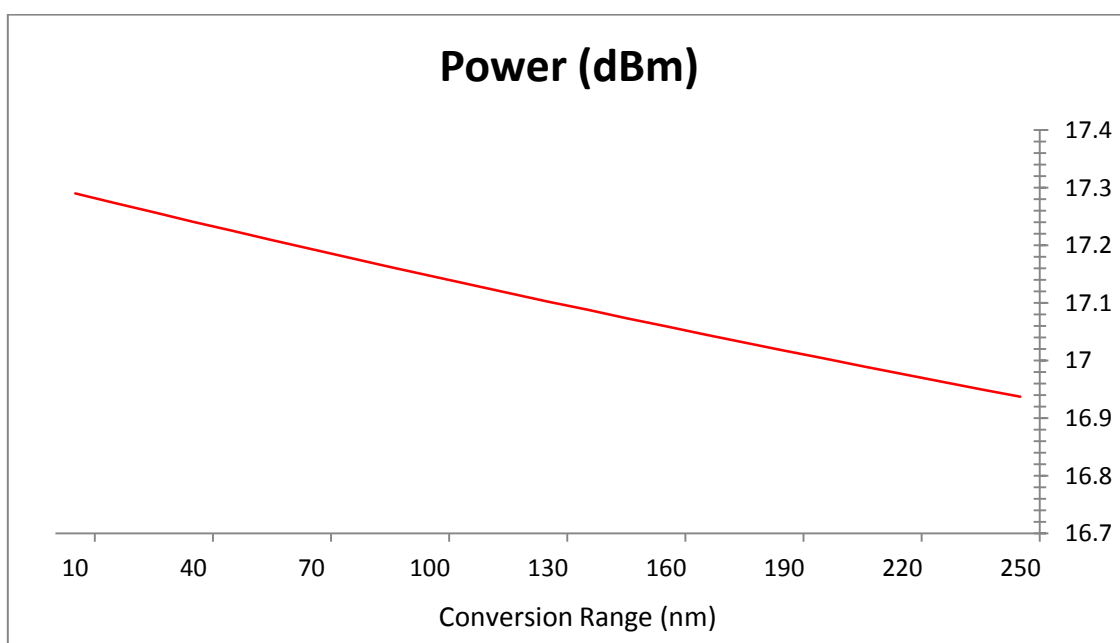

Figure 4- 7: Waves power for various WCR

The input wavelength has been varied from 1550 nm to 1310 nm and each step the input wavelength is reduced by 10 nm. That means, the conversion is run from (1550, 1540, 1530, 1520, 1510, 1500, 1490, 1480, 1470, 1460, 1450, 1440, 1430, 1420, 1410, 1400, 1390, 1380, 1370, 1360, 1350, 1340, 1330, 1320, 1310 nm) to 1300 nm. The waves' powers decreased linearly when the WCR is increased.

As shown in figure 4.7, the output-wave's power of conversion range of 250 nm (from 1550 nm to 1300 nm) is just 16.93 dBm. While the output-wave's power of conversion range of 10 nm (from 1310 nm to 1300 nm) has reached 17.30 dBm. That means the converted wave's power is inversely proportional to the WCR. Therefore, the WCR has to be minimized as much as possible to maintain higher wave power for the converted wavelength.

In the proposed multicast switch in this work, the WCR has been decreased by a significant value compared with other work as explained in section 4.5 in this chapter.

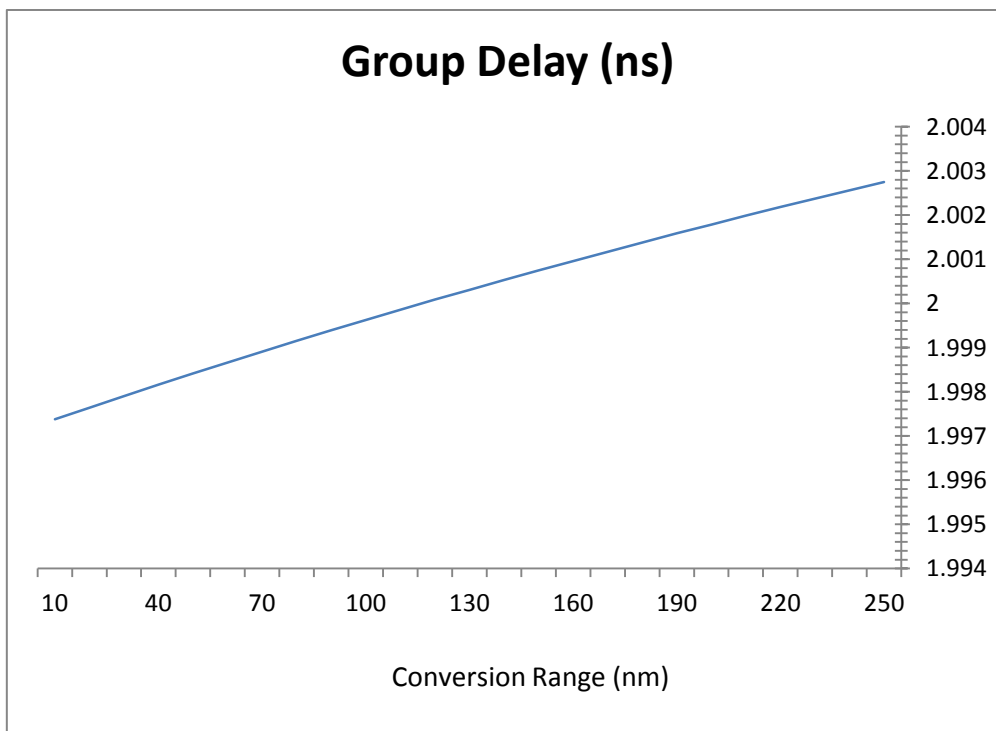

Figure 4- 8: Group delay for various WCR

The four-wave mixing conversion has been built as shown in figure 4.6 using VPI transmission maker optical systems software. The input wavelength has been varied

also from 1550 nm to 1310 nm and it decreased by 10 nm in each step exactly as in the previous experiment to measure the converted wave's powers. The group delay has a linear relationship with the WCR and it is directly proportional with the WCR as shown in figure 4.8. When the WCR is increased from 10 nm (from 1310 nm to 1300 nm) to 250 nm (from 1550 nm to 1300 nm) the group delay is also increased from 1.997 ns to about 2.003 ns. So, the WCR difference between each two conversions which is 10 nm, leads to (~ 210 fs). While the GD for the ultra-wide conversion range band (250 nm), reached approximately (5375 fs) which is equal to (5.375 ps). Therefore, this work in this chapter has taken care of the WCR and it has characterised it so that it can be used to reduce the range as much as possible.

4.3.4.4 Conversion Methodologies

There are different wavelengths conversions methodologies that have been used to obtain better performance. Wavelength conversions have various conversion degree and ability to convert all or some wavelengths. Moreover, in the wavelength conversion there are different methods of using one converter to convert ultra-wide band or using several number of converters in serial to make ultra-wide band of wavelength conversion. The second method is preferred in this work despite its expensive components but it has better output because of its high power and low GD.

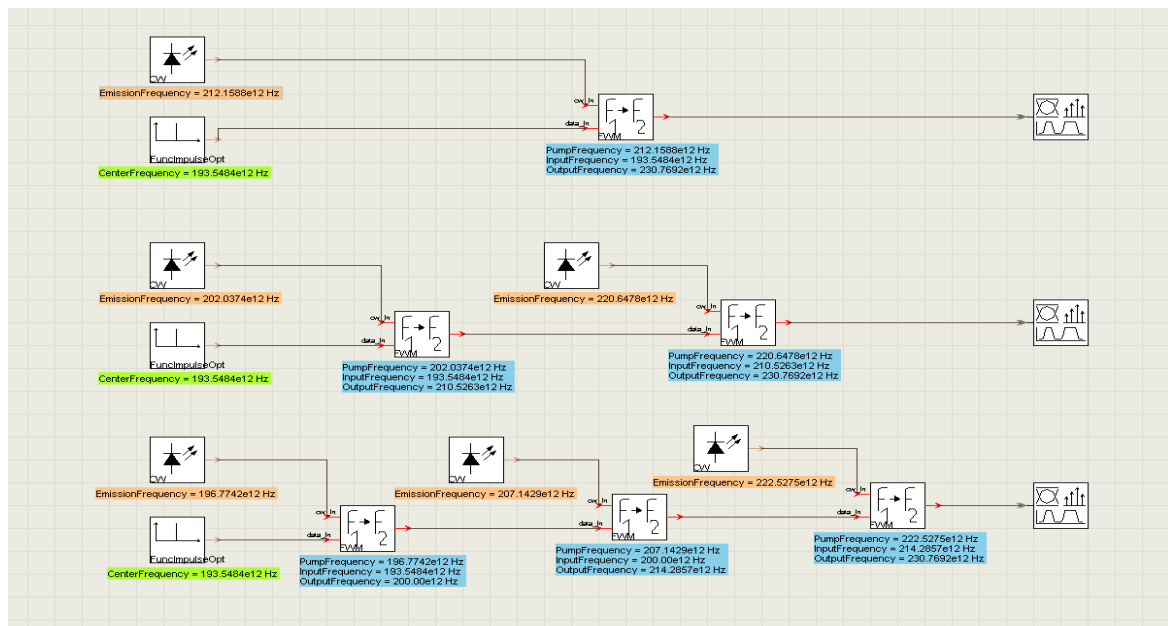

Figure 4- 9: Different methodology of WC

The results show the significant difference between these three conversion methods.

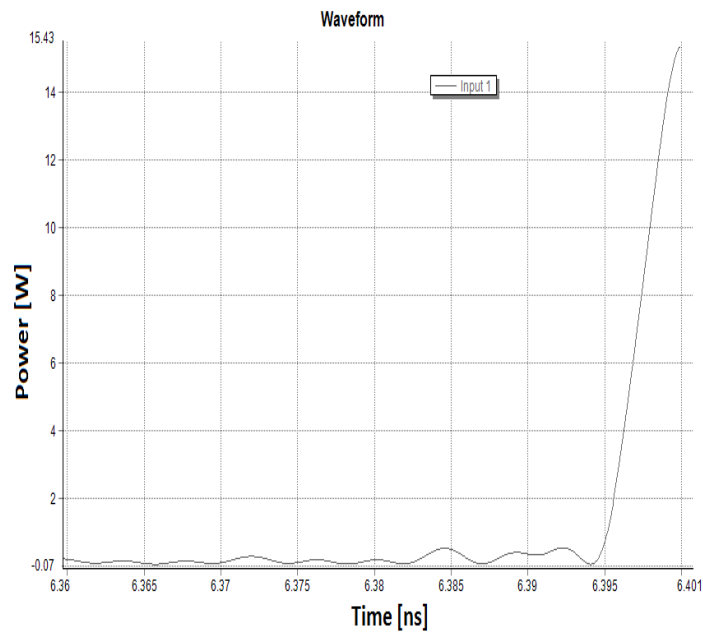

Figure 4- 10: Wave power for a single converter

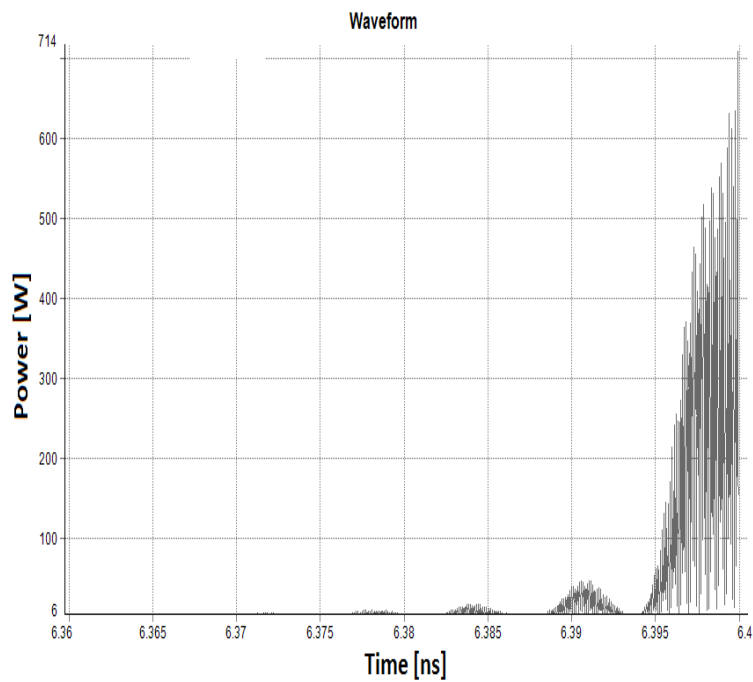

Figure 4- 11: Wave power for two consecutive converters

The WCR for these three methods has been experimented for converting wavelength 1550 nm to wavelength 1300 nm, which means WCR of 250 nm. The setup has followed the values shown in table 4.3. The wave power for wavelength converted by just one single WC convert range of 250 nm is just about 15.35 W

(~11.861 dBW), while the wave power for wavelength converted by two consecutive WCs each one convert 125 nm has reached approximately 710 W (~ 28.573 dBW).

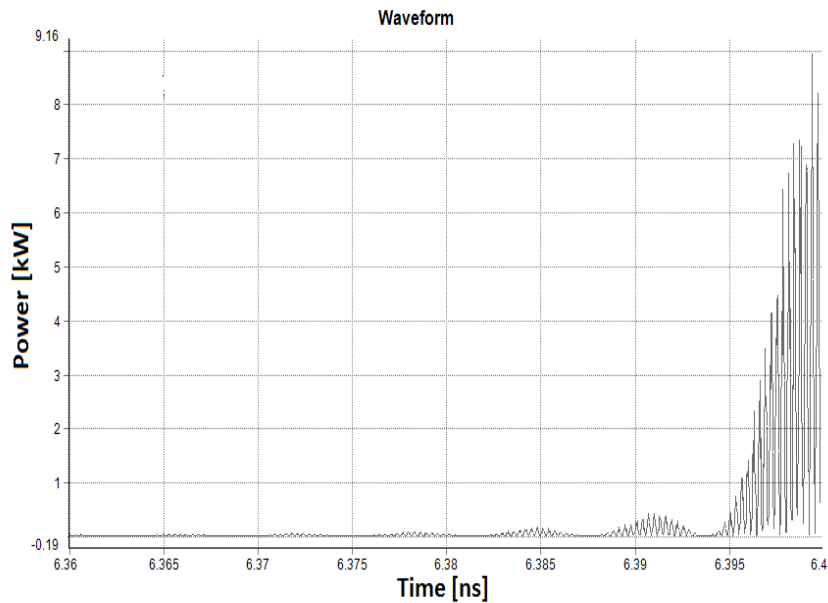

Figure 4- 12: Wave power for three consecutive converters

However, the wave power for wavelength converted by three sequential WCs has obtained the highest value which has reached 8925 W (39.506 dBW). Using three consecutive WCs has increased the wave power by a significant value greater than using two and one converters. Utilizing two sequential WCs also has higher wave power than utilising just one WC. The work in this thesis has taken advantage of this fact to build new multicast switch that increases waves' powers which lead to obtain high quality of service (QoS). At the same time it has at least the same number of wavelength converters, if not less.

One Single Wavelength Converter pump power is 1 W, input power is 1 mW	Wavelength nm	1550	1300		
	Frequency THz	193.5484	230.7692		
	Pump Frequency THz	212.1588			
Two Consecutive Wavelengths Converters pump power is 1 W, input power is 1 mW	Wavelength nm	1550	1425	1300	
	Frequency THz	193.5484	210.5263	230.7692	
	Pump Frequency THz	202.0374	220.6478		

Three Consecutive Wavelengths Converters pump power is 1 W, input power is 1 mW	Wavelength nm	1550	1500	1400	1300
	Frequency THz	193.5484	200	214.2857	230.7692
	Pump Frequency THz	196.7742	207.1429	222.5275	

Table 4- 3: Three WCs methods setup

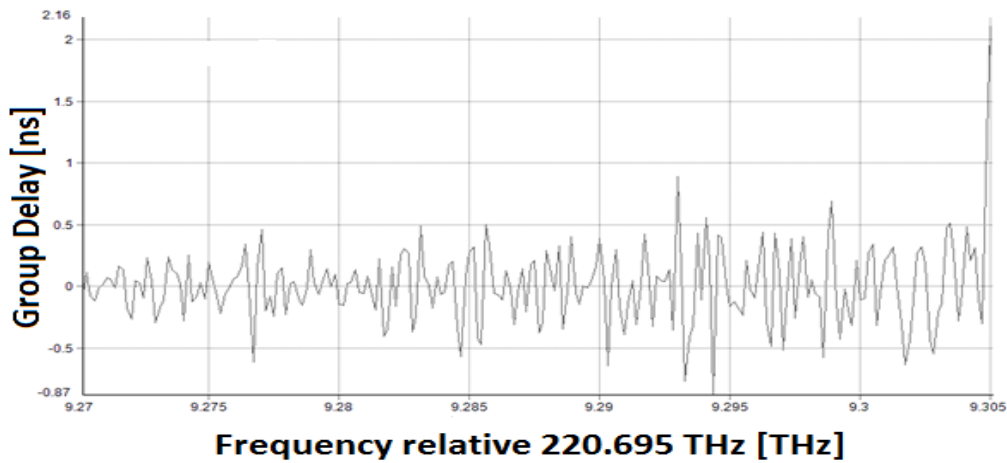

Figure 4- 13: Group delay for a single converter

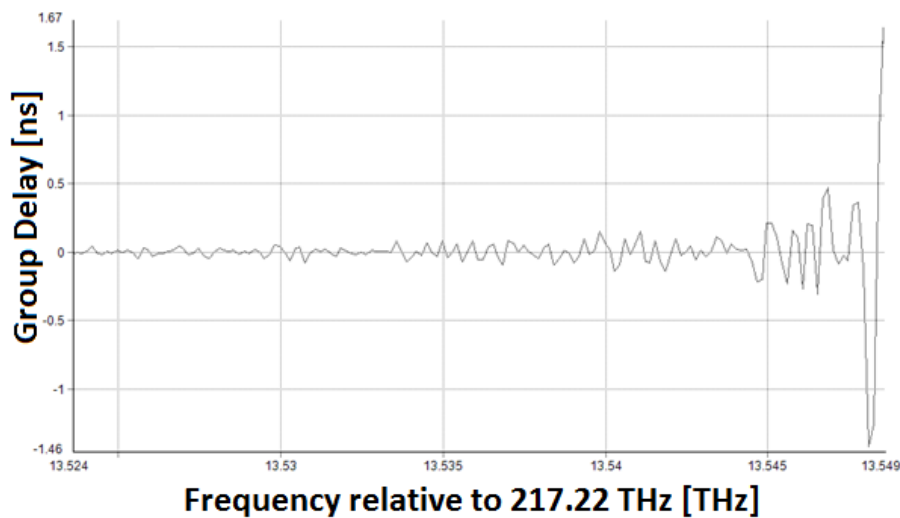

Figure 4- 14: Group delay for two consecutive converters

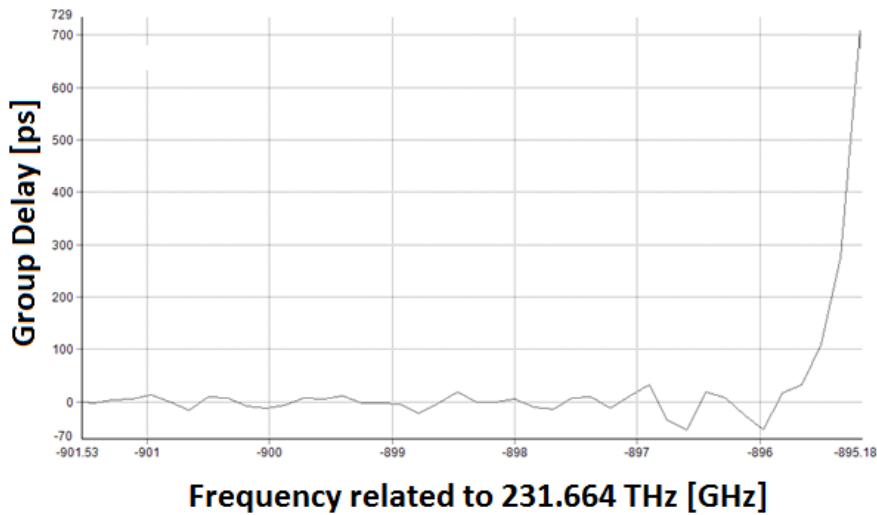

Figure 4- 15: Group delay for three consecutive converters

The two conversion methods have been built following the same setup in table 4.3 and the GD results are shown in figure 4.13, 4.14 and 4.15. Using one WC has taken about 2.15 ns to convert wavelength 1550 nm to 1300 nm. The two sequential WCs methodology has taken approximately 1.629 ns. However, the lowest GD has been recorded by utilising three consecutive WCs and it was approximately just 0.7 ns. That means the third procedure has minimized group delay by about 1.45 ns. This advantage has been taken in account in the proposed multicast switch in this chapter to reduce group delay for the whole network.

4.4 Multicast Switch Techniques

Multicast switching allows the input signal to be routed to any number of output fibres. By using multicast switching with light splitters and wavelength converters, the input wavelengths can be routed from any input fibre to any number of output fibres for any wavelength. A four-wavelength 2x2 fibre switch using wavelength converters (WC) and light splitters (LS) is illustrated in Fig. (4.16).

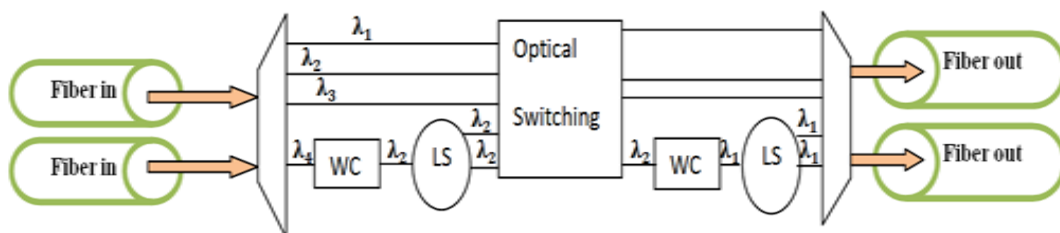

Figure 4- 16: 2x2 C-S-C-S multicast switch

The switch [36] has been proposed to multicast wavelengths using wavelength conversion. In this switch, the number of converters is more than the light splitters to build it and it is called S-C multicast switch. It is known that using converters is a significant cost and in any network, the designer has to find the most ideal infrastructure as a trade-off between cost, power consumption, size, etc. Multicast request is illustrated in figure 4.17, where the server multicasts data to all four computers. The red wavelengths are busy with other data transfer, while green wavelengths are available for sending data. The multicast request is using wavelength one (λ_1) to the multicast switch. The switch has to use WC to send data to all clients. However, as shown in figure 4.17, the wavelength number three is available to clients one and three, while wavelength number four is available to clients two and four.

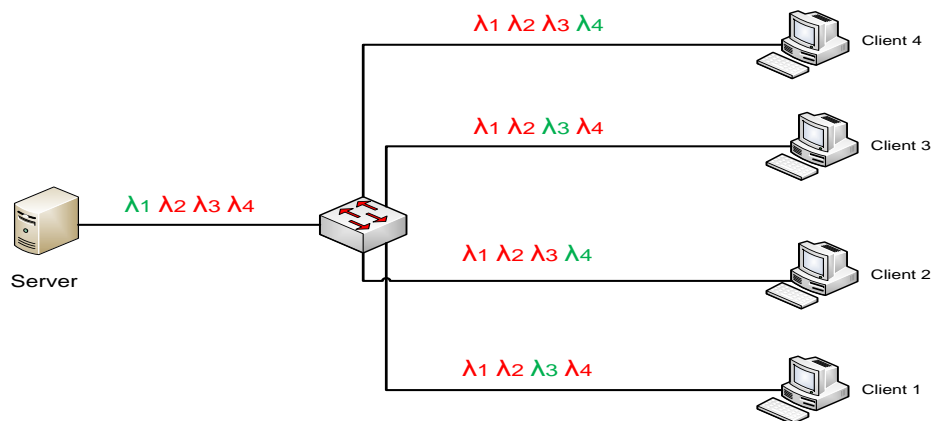

Figure 4- 17: Multicast Switch. Green are available wavelengths, red are non-available wavelengths

This switch has followed two steps method, which is called (S-C). The switch performance is to split the input wavelength to multiple wavelengths and then convert them to any requested wavelength as shown in Fig (4.18). Therefore, it needs one splitter to divide input wavelength to four and four converters to convert λ_1 as input wavelength to $2 \times \lambda_2$ and $2 \times \lambda_3$ in the output fibres.

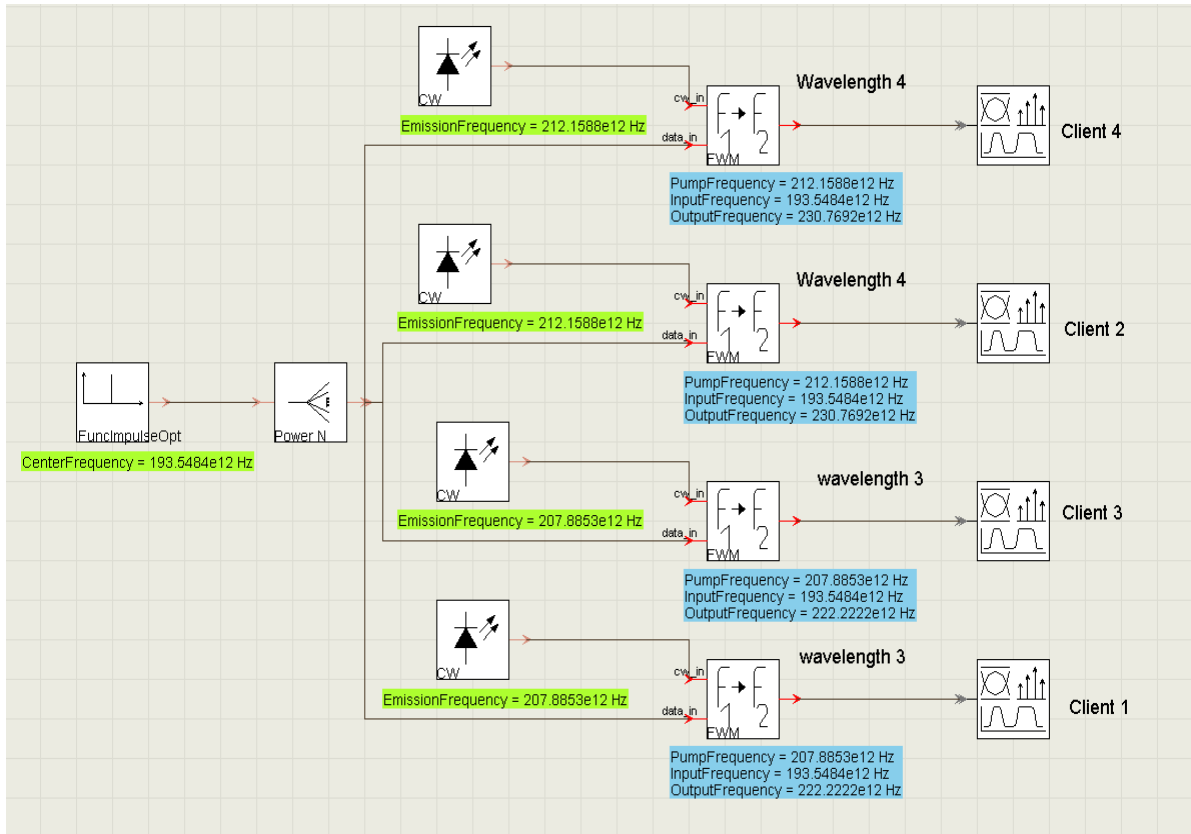

Figure 4- 18: S-C Wavelengths Multicast Switching

A better switch has been produced [36] by decreasing the number of converters. The new switch is called split convert split (S-C-S). It multicasts a wavelength to different destinations with three steps, instead of two steps as it proposed in (S-C) switch. The input wavelength has to be split to the requested number of wavelengths in the first step, then converted to the requested wavelengths in the second step, and in the final step split to the number of the children requested as shown in Fig (4.19). By this method, S-C-S switch needs three splitters and two converters to produce $2 \times \lambda_2$ and $2 \times \lambda_3$ outputs from a λ_1 as input wavelength.

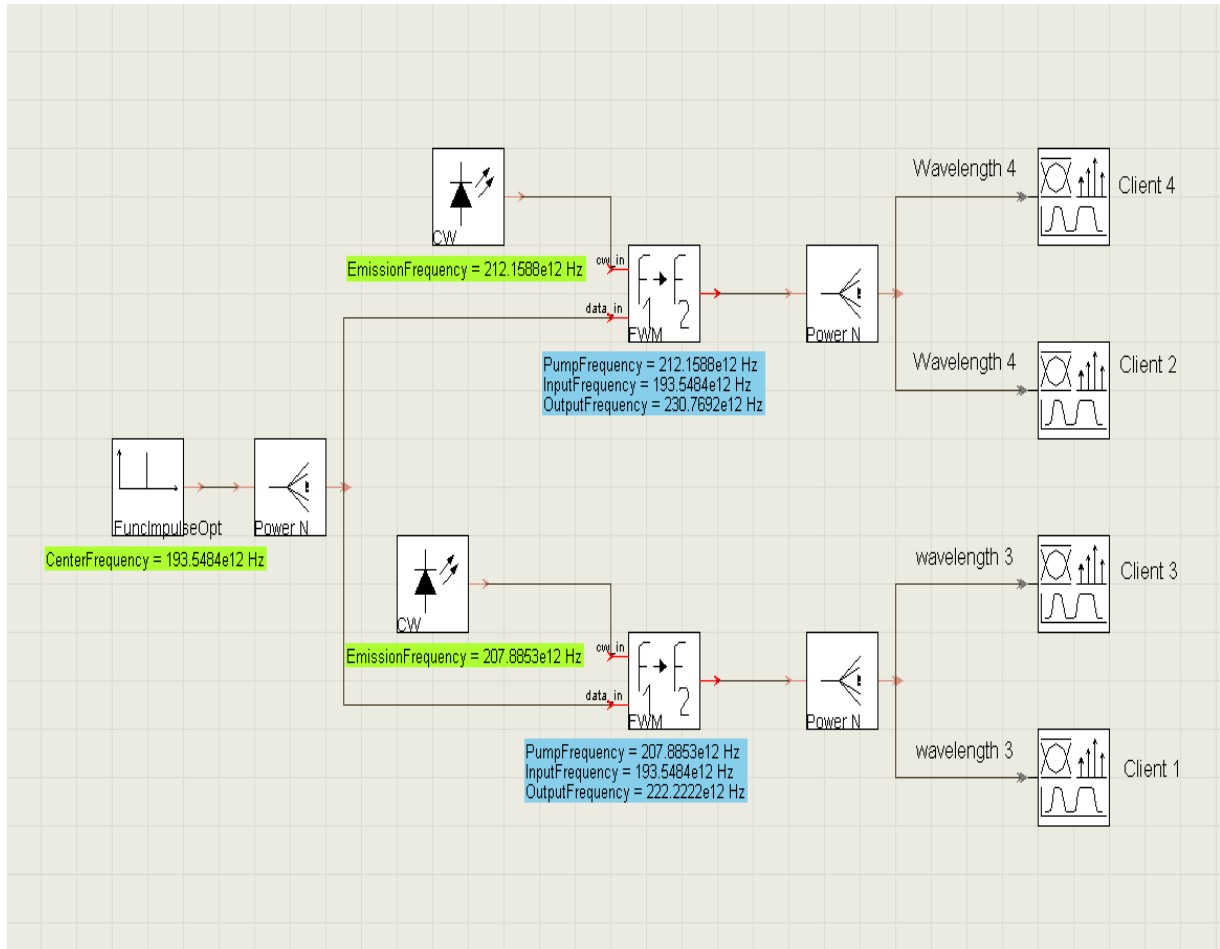

Figure 4- 19: S-C-S Wavelengths Multicast Switching

In our proposed switch, there are two steps for each wavelength required. The new proposed switch is called Split-Convert-Split-Convert switch (S-C-S-C). It splits the input wavelength to the required number of wavelengths if needed and then converts it to the nearest required wavelength and finally splits it to the required number of the output wavelength if there is need of another wavelength, then it converts the converted wavelength to the new requested wavelength and splits it to the required number of outputs. S-C-S-C switch has decreased the number of splitters compared to the S-C-S switch and reduced also number of WC compared with the S-C switch. It repeats these steps to obtain any number of other wavelengths requested in the output as shown in Fig (4.20). By our method we need two splitters and two converters to get $2 \times \lambda_2$ and $2 \times \lambda_3$ output form a λ_1 as input wavelength.

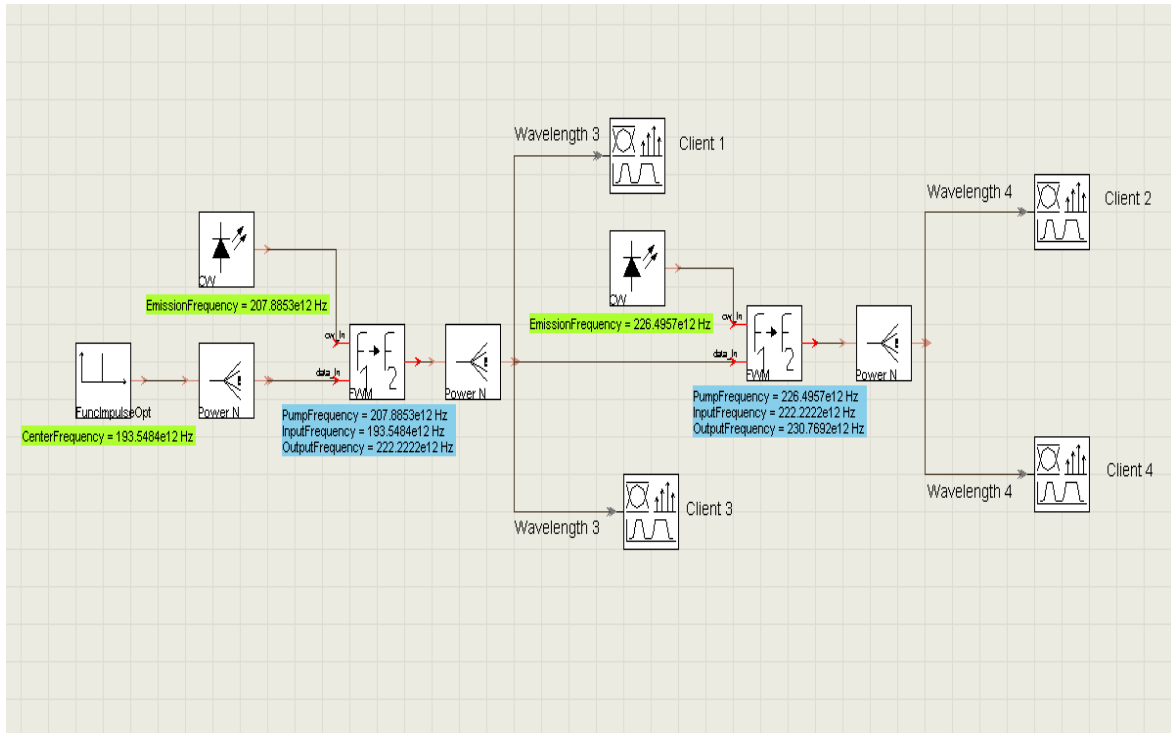

Figure 4- 20: S-C-S-C Wavelength Multicast Switching

4.5 Results and Discussion

By our suggested switch we have reduced number of light splitters (LS), wavelength converters (WC), decreased the conversion degree (CD), and the conversion range (CR).

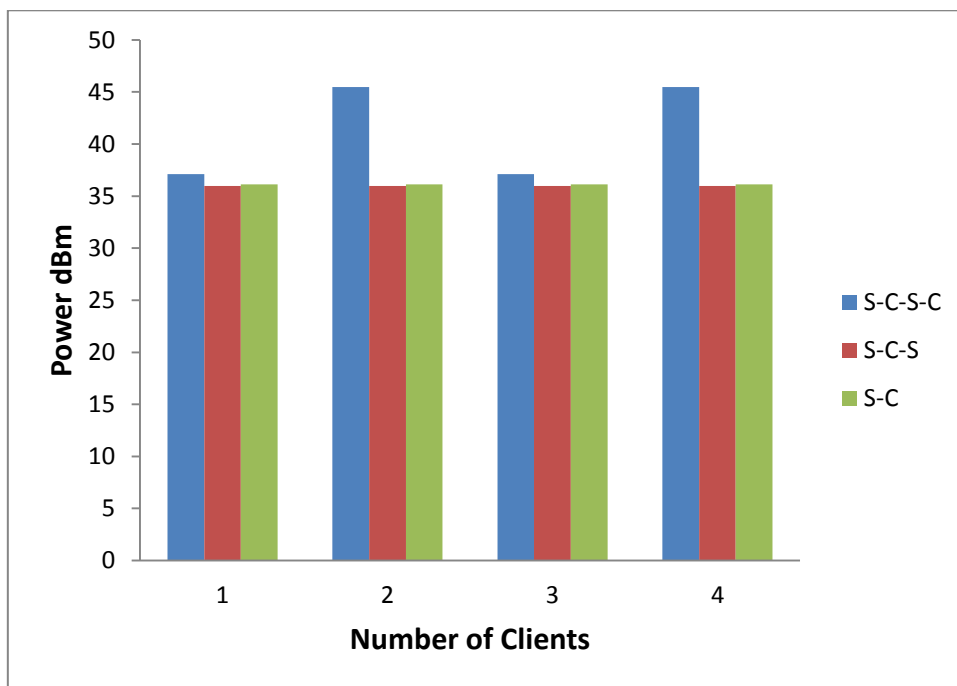

Figure 4- 21: Wave power for different wavelengths multicast switches in quaternary tree

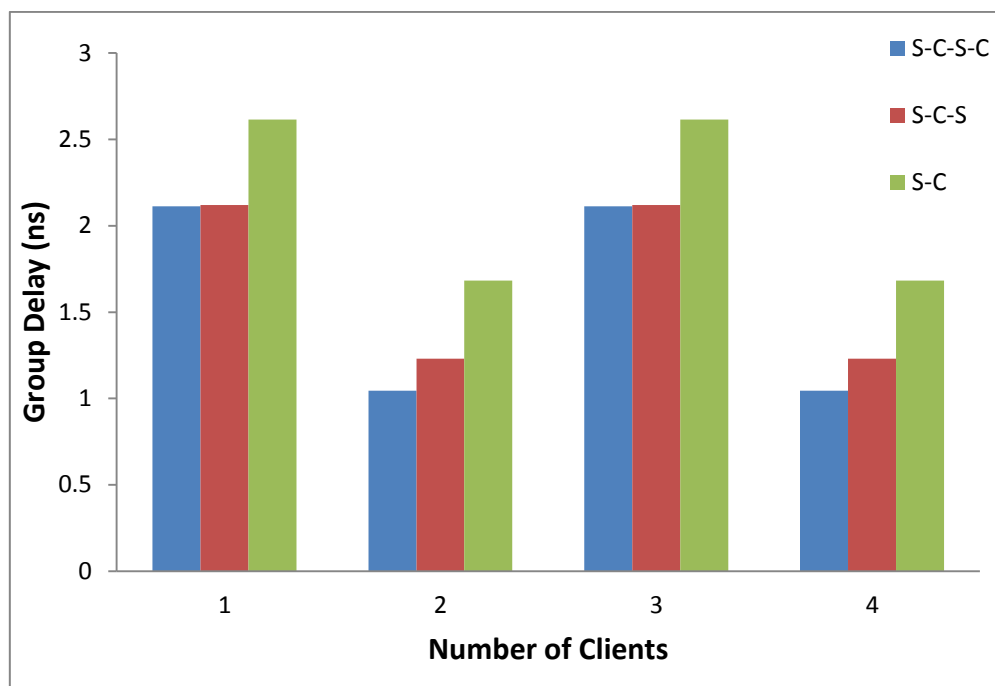

Figure 4- 22: Group delay for different wavelengths multicast switches in quaternary tree

The S-C-S-C wavelength conversion design has taken advantage of reducing WCR to increase converted wave power and decrease GD. The proposed multicast switch has taken advantage of connecting the WCs in series instead of parallel as is used in S-C and S-C-S multicast switches.

The multicast request is quaternary tree, which is illustrated in figure 4.17, has four wavelengths in the network and there are just two wavelengths available to clients, which are wavelength three and wavelength four. One wavelength is available to each client and the request has been generated randomly.

Our wavelength multicast switch has increased average wave power up to 14.8% compared with S-C-S conversion method and 14.3% compared with S-C conversion method. The S-C-S-C methodology has decreased also GD by about 34.1% compared with the S-C conversion procedure and about 5.76% compared with the S-C-S conversion process.

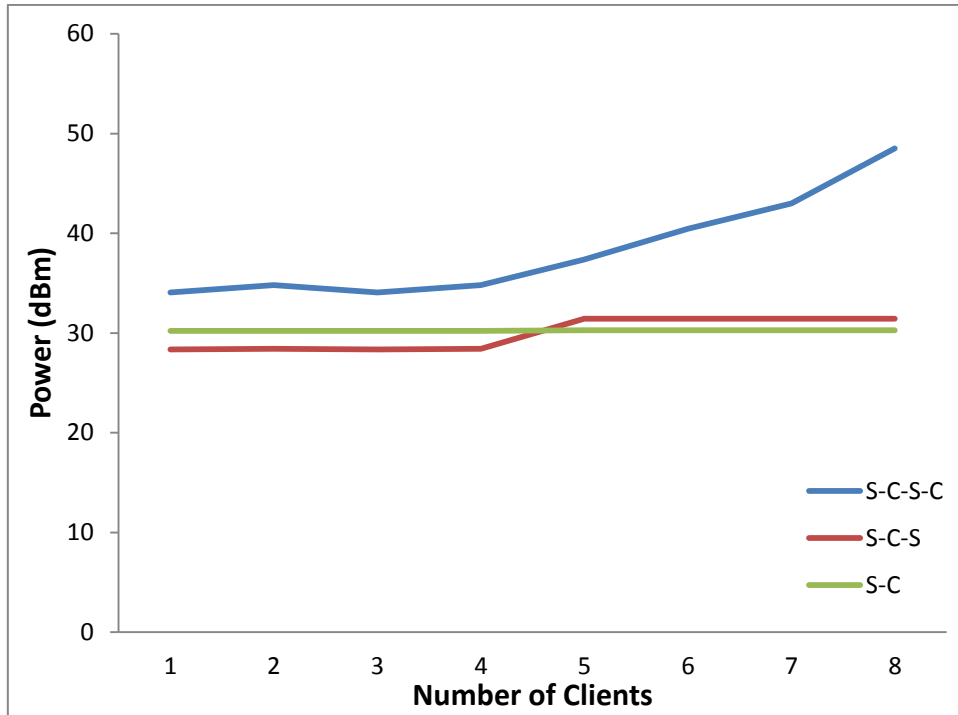

Figure 4- 23: Wave power for different converted wavelengths in multicast switches in octonary tree

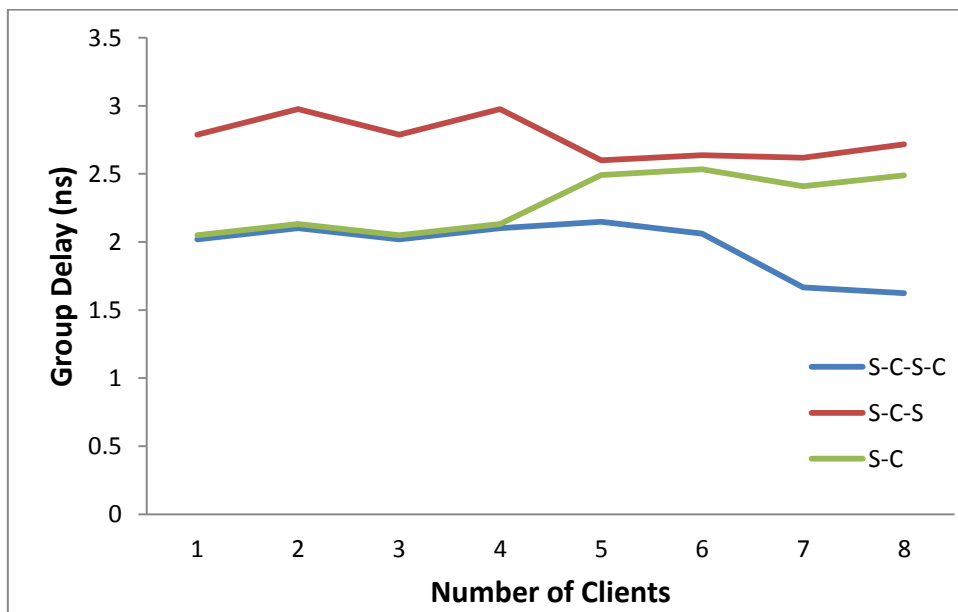

Figure 4- 24: Group delay for different converted wavelengths in multicast switches in octonary tree

Power and group delay has been simulated by using VPI transmission maker software. The octonary tree has been used to compare the three multicast switches. There are eight wavelengths used in this multicast, the first and third clients have the same wavelength available which is wavelength two, while the second and fourth

clients have wavelength three. The other remaining clients has different wavelength to each one. This is a random generation to test the proposed multicast switch. The input wavelength is 1550 nm and the output wavelengths are (1510, 1475, 1440, 1405, 1370, 1335 and 1300). The results show that the S-C-S-C has improved the average wave power by 28% and 26.92% compared with S-C-S and S-C respectively. The S-C-S-C has improved GD also by about 28.7% and 12.98% compared by S-C-S and S-C respectively. The graphs are not straight lines because each node has its own specific characteristics.

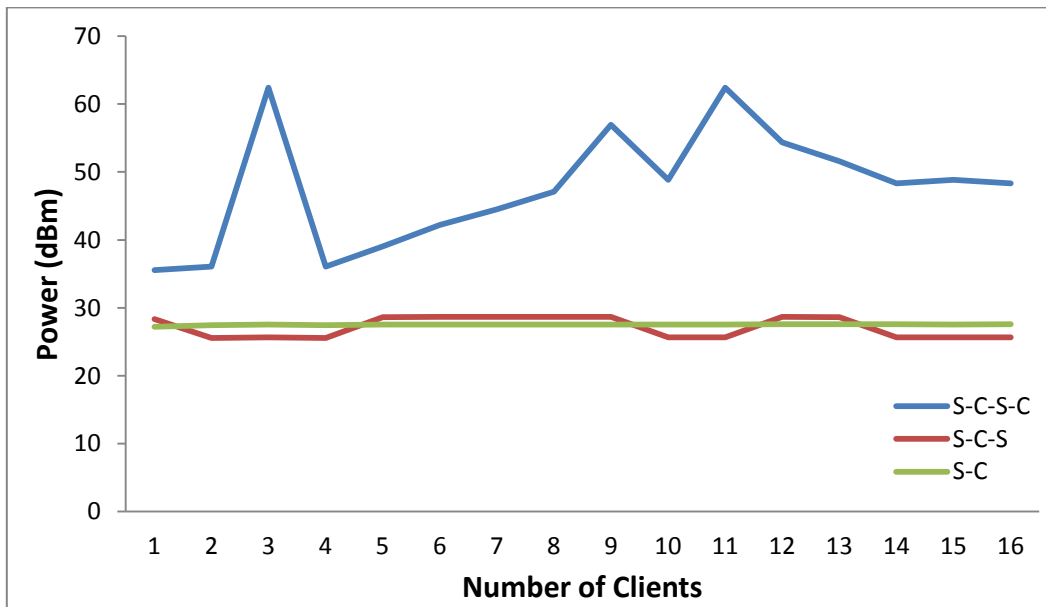

Figure 4- 25: Wave power for different converted wavelengths in multicast switches in sedenary tree

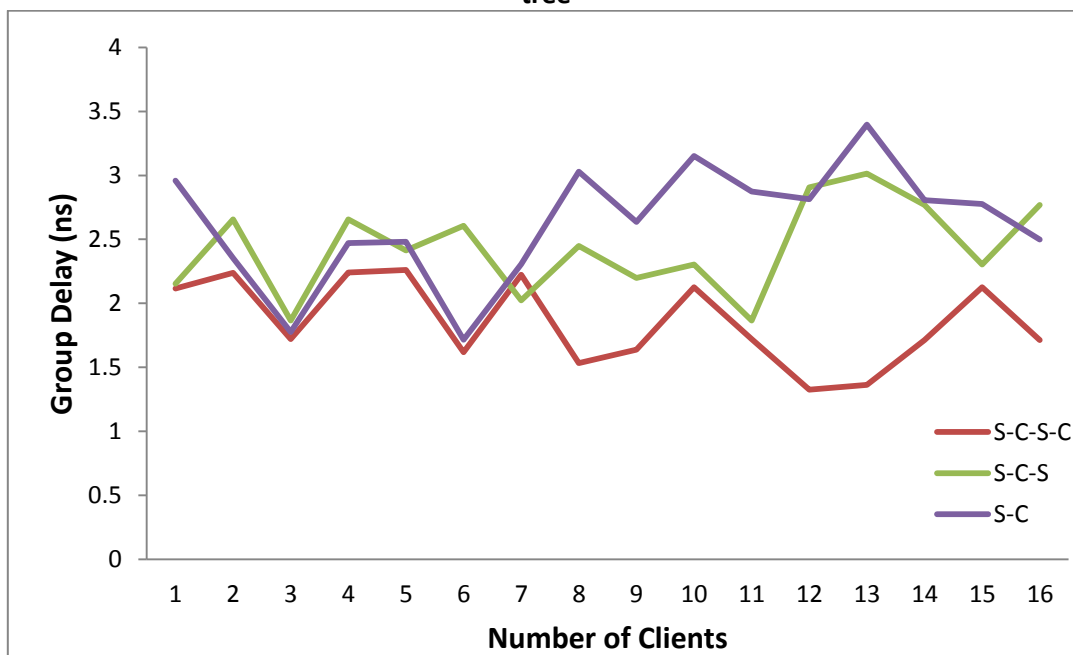

Figure 4- 26: Group delay for different converted wavelengths in multicast switches in sedenary tree

By implementing a sedentary tree (hexadecimal) which contains sixteen ports, the wave power and GD results are illustrated in figure 4.24 and 4.25 respectively. Each port has one wavelength available and the total number of available wavelengths in the network is sixteen wavelengths. There are some ports that have the same wavelength such as (11 and 3, 10 and 15, 2 and 4), while other ports have different wavelengths than others. There is a significant optimization in our proposed multicast switch compared with the other two multicast switches related to the converted wave power. While in the group delay, the improvement of our proposed multicast switch is still fairly well compared with the other two multicast switches. The results in figures 4.25 and 4.26 show that the S-C-S-C switch has reduced GD by about 21.66% and 26.9% compared with S-C-S and S-C respectively. The S-C-S-C has improved average wave power by 76.46% and 73.19% compared by S-C-S and S-C respectively.

4.6 Summary

In this chapter, wavelength switching has been discussed and analysed using VPI software. The wavelength switching in this chapter has used light splitters and wavelength converters to multicast waves to various clients. There are many factors affecting the transmitted signal's power and group delay such as wavelength conversion range (WCR), wavelength conversion techniques and wavelength methodologies.

The signal power has been affected inversely with WCR. Therefore, the proposed switch in this chapter has minimized conversion range as much as possible, while GD has been affected directly with the WCR and the proposed switch has reduced GD by decreasing WCR.

In this chapter, the wavelength conversion techniques has been analysed and proved that using FWM technique has the best transparency, bit per second quantity and converted signal's power. Therefore, the FWM has been chosen to be the technique to convert wavelengths in this work.

Wavelength conversion methodology has been investigated for different conversions using single or several converters connected in series. Connection of sequential

converters has better performance related to signal power and GD. Increasing the number of sequential converters leads to a decrease in GD and an increase in signal power. Therefore, this work in this chapter has taken advantage of these characteristics in the wavelength multicast switch.

The switch has been proposed in this chapter to multicast wavelengths to different clients. It concentrates on increasing signal power and decreasing GD. It has been compared with two others switches to show its better performance.

References

- [1] Jianping Wang; Biao Chen; Uma, R. N., "Dynamic wavelength assignment for multicast in all-optical WDM networks to maximize the network capacity," *Selected Areas in Communications, IEEE Journal on*, vol.21, no.8, pp.1274-1284, Oct. 2003.
- [2] Gee-Swee Poo; Zhou, Y., "A, new multicast wavelength assignment algorithm in wavelength-routed WDM networks," *Selected Areas in Communications, IEEE Journal on*, vol.24, no.4, pp.2-12, 2006.
- [3] Young Hwan Kwon; Bok Rae Jung; Wong, E.; Jun Kyun Choi, "Multicast scheduling mechanism to support less loss ratio for frequently used multicast service in multicast switch," *Information Networking, 2009. ICOIN 2009. International Conference on*, vol., no., pp.1-5, 21-24 Jan 2009.
- [4] Y. ngn-mcasts, "NGN multicast-based service framework", *ITU-T SG 13 Draft Recommendation*, TD-WP3-0419, Geneva, Switzerland, vol., no., pp.16-27, May 2008.
- [5] Chunde Yang; Zhenyu Zhong, "A P2P streaming media application layer multicast technology under the constraint of delay and bandwidth," *Consumer Electronics, Communications and Networks (CECNet), 2011 International Conference on*, vol., no., pp.3847-3850, 16-18 April 2011.
- [6] Sambo, N.; Meloni, G.; Berrettini, G.; Paolucci, F.; Malacarne, A.; Bogoni, A.; Cugini, F.; Poti, L.; Castoldi, P., "Demonstration of data and control plane for optical multicast at 100 and 200 Gb/s with and without frequency conversion,"

- Optical Communications and Networking, IEEE/OSA Journal of*, vol.5, no.7, pp.667-676, July 2013.
- [7] Gong, Long; Zhou, Xiang; Liu, Xiahe; Zhao, Wenwen; Lu, Wei; Zhu, Zuqing, "Efficient resource allocation for all-optical multicasting over spectrum-sliced elastic optical networks," *Optical Communications and Networking, IEEE/OSA Journal of*, vol.5, no.8, pp.836-847, Aug. 2013.
- [8] Jawhar, S.; Cousin, B.; Lahoud, S., "Efficient placement of light splitters in heterogeneous optical networks," *High-Capacity Optical Networks and Enabling Technologies (HONET), 2010*, vol., no., pp.204-209, 19-21 Dec. 2010.
- [9] Ozoptics, "BEAM SPLITTERS/COMBINERS", Ottawa, Canada, [available] online: http://www.ozoptics.com/ALLNEW_PDF/DTS0095.pdf, accessed 02/09/2013, vol., no., pp.1-8, Jan 2011.
- [10] Optical light splitter, Shenzhen Jassonfiber Optoelectronics Co., LTD, Long Gang of Shenzhen, P. R. China [available] online: <http://www.jassonfiber.com/index.php?s=/nview/120/607.html>, accessed 02/09/13.
- [11] David Goff R., Kimberly Hansen S., "Fiber Optic Reference Guide: A Practical Guide to Communications Technology", Taylor & Francis, USA, vol. 260, no. 3, pp. 115-117, 2002.
- [12] Xiangdong Qin; Yuanyuan Yang, "Multicast connection capacity of WDM switching networks with limited wavelength conversion," *Networking, IEEE/ACM Transactions on*, vol.12, no.3, pp.526-538, June 2004.
- [13] Dewiani; Hirata, K.; Higami, Y.; Kobayashi, S.-Y., "Dynamic routing and wavelength assignment in multifiber WDM networks with sparse wavelength conversion," *ICT Convergence (ICTC), 2012 International Conference on*, vol., no., pp.567-572, 15-17 Oct. 2012.
- [14] González-Ortega, M.A.; López-Ardao, J.C.; Suárez-González, A.; Fernandez-Veiga, M.; Lopez-Garcia, C., "Loss Differentiation in OBS Networks With Limited or No Wavelength Conversion," *Lightwave Technology, Journal of*, vol.28, no.13, pp.1944-1957, July1, 2010.
- [15] Qirui Huang; Wen-De Zhong, "Wavelength-Routed Optical Multicast Packet Switch with Improved Performance," *Lightwave Technology, Journal of*, vol.27, no.24, pp.5657-5664, Dec.15, 2009.

- [16] Qiwu Wu; Xianwei Zhou; Jianping Wang; Zhizhong Yin; Lingzhi Jiang, "A Low-Cost Delay-Constrained Routing and Wavelength Assignment Algorithm in WDM Networks with Sparse Wavelength Conversions," *Photonics and Optoelectronics, 2009. SOPO 2009. Symposium on*, vol., no., pp.1-4, 14-16 Aug. 2009.
- [17] Tintor, V.; Urošević, D.; Anđelić, B.; Radunović, J.; Mladenović, N., "Variable neighbourhood search for resolving routing and wavelength assignment problem in optical wavelength-division multiplexing networks," *Communications, IET*, vol.5, no.14, pp.2028,2034, Sept. 23 2011.
- [18] Iyer, S.; Singh, S.P., "A novel offline PLI-RWA, regenerator placement and wavelength converter placement algorithm for translucent optical WDM networks," *Signal Processing and Communications (SPCOM), 2012 International Conference on*, vol., no., pp.1,5, 22-25 July 2012.
- [19] Gvind Agrawal, "Applications of Nonlinear Fiber Optic", *Academic Press*, vol. no., pp. 349-353, Jul 2010.
- [20] Matsuura M.; Calabretta N.; Raz O.; and Dorren H. J. S., "Multichannel wavelength conversion of 50-Gbit/s NRZ-DQPSK signals using a quantum-dot semiconductor optical amplifier," *Opt. Express*, vol. 19, no. 26, pp. B560–B566, Dec. 2011.
- [21] Jianjun Yu; Ming-Fang Huang, "Polarization insensitive wavelength conversion techniques for 100Gb/s polarization-diversity signal," *OptoElectronics and Communications Conference, 2009. OECC 2009. 14th*, vol., no., pp.1-2, 13-17 July 2009.
- [22] Perez-Serrano, A.; Javaloyes, J.; Balle, S., "Multichannel Wavelength Conversion Using Four-Wave Mixing in Semiconductor Ring Lasers," *Photonics Technology Letters, IEEE*, vol.25, no.5, pp.476-479, March1, 2013.
- [23] Krishna Sivalingam M.; Suresh Subramaniam, "Optical WDM Networks: Principles and Practice", Springer publisher, The springer international series in engineering and computer science, vol. 352, no., pp. 62-68, Mar 2000.
- [24] Anupjeet Kaur; Kulwinder Singh; Bhawna Utreja, "Performance analysis of semiconductor optical amplifier using four wave mixing based wavelength Converter for all Optical networks", *Engineering Research and Applications (IJERA), International Journal of*, vol. 3, no. 4, pp. 108-113, Aug 2013.

- [25] Farah Diana Mahad; Abu Sahmah Supa'at M.; Idrus Sevia Mahdaliza; Forsyth David, "Comparative performance testing of SOA wavelength conversion techniques for future all optical systems," *Light and Electron Optics (Optik), International Journal for*, vol. 124, issue 12, pp. 1254-1259 Jun 2013.
- [26] Yousuf Khambaty, "Efficient Wavelength Conversion Using Four Wave Mixing in Semiconductor Optical Amplifier for Intensity Modulated Differential Phase Shift Keying Signal", The University of Texas at San Antonio. Electrical & Computer Engineering, ProQuest, vol., no., pp. 34-35, 2008.
- [27] Matsuura, M.; Kishi, N.; Miki, T., "Ultra wideband Wavelength Conversion Using Cascaded SOA-Based Wavelength Converters," *Lightwave Technology, Journal of*, vol.25, no.1, pp.38-45, Jan. 2007.
- [28] Lacey J. P. R.; Pendock G. J.; Tucker R. S., "All-optical 1300-nm to 1550-nm wavelength conversion using cross-phase modulation in a semiconductor optical amplifier," *IEEE Photon, Technol. Letter of*, vol. 8, no. 7, pp. 885–887, Jul. 1996.
- [29] Robert K. Willardson, Eicke R. Weber, Elsa Garmire, Alan Kost, "Nonlinear Optics in Semiconductors II". *Academic Press*, vol. 49, no., pp. 146-148, Nov 1998.
- [30] Ophir, N.; Chan, J.; Padmaraju, K.; Biberman, A.; Foster, A.C.; Foster, M.A.; Lipson, M.; Gaeta, A.L.; Bergman, K., "Continuous Wavelength Conversion of 40-Gb/s Data Over 100 nm Using a Dispersion-Engineered Silicon Waveguide," *Photonics Technology Letters, IEEE*, vol. 23, no. 2, pp. 73-75, Jan.15, 2011.
- [31] Sylvestre, T.; Maillotte, H.; Lantz, E.; Tchofo Dinda, P.; Moubissi, A. B.; Pitois, S., "Wavelength conversion from 1.3 μm to 1.5 μm bands in a nonlinear dispersion-shifted fibre," *Lasers and Electro-Optics Europe, 2000. Conference Digest. 2000 Conference on*, vol., no., pp. 10-15 Sept. 2000.
- [32] Robert Schilling A.; Robert Joseph Schilling; Sandra Harris L.; "Fundamentals of Digital Signal Processing Using MATLAB", *Cengage Learning*, vol. 766, no., pp. 350-354, Dec 2010.
- [33] Thyagarajan K. S.; Ajoy Ghatak, "Fiber Optic Essentials", *John Wiley & Sons*, vol. 344, no., pp. 57-62, Aug 2007.

- [34] Raymond Serway A.; Chris Vuille, "College Physics, Volume 1", *Cengage Learning*, vol., no., pp.445-449, Jan 2011.
- [35] Shawn Jackman M.; Matt Swartz; Marcus Burton; Thomas Head W.; "CWDP Certified Wireless Design Professional Official Study Guide: Exam PW0-250", *John Wiley & Sons*, vol., no., pp., Feb 2011.
- [36] Qirui Huang; Wen-De Zhong, "Wavelength-Routed Optical Multicast Packet Switch with Improved Performance," *Lightwave Technology, Journal of*, vol.27, no.24, pp.5657-5664, Dec.15, 2009.
- [37] Gee-Swee Poo and Yinzhu Zhou, "A New Multicast Wavelength Assignment Algorithm in Wavelength-Routed WDM Networks", *IEEE Journal on selected areas in communications*, vol. 24, no. 4, pp. 2-12, April 2006.

Chapter Five

Distributed Wavelengths Assignment Processes

5.1 Introduction

Wavelength assignment (WA) has a significant importance in wavelength division multiplexing (WDM) in optical fibre network. To allocate a specific candidate wavelength from a source to selected destination/s, there are numerous algorithms applied. Different topologies, mesh, tree and ring, have been investigated using either uni-or multi-casting. Wavelength assignment schemes can be divided into three schemes [1] static, dynamic and hybrid. In the static wavelength assignment (SWA) scheme, a specific wavelength is dedicated to each destination; therefore the number of destinations is equal to the number of available wavelengths in the network.

However, it is used in small and limited networks and it is also used in sensitive networks when the wavelength must be always available like in health and military use. To obtain an ideal idea about static wavelength assignment, we can assume that a graph G and it represents a network. Each link between two nodes represents a fibre link. Each call has to assign one wavelength to reach its destination. To assign five calls (figure 5.1 a) from the optical transmitter to all five homes, it needs one wavelength for each call. That means it needs five wavelengths to serve all these calls.

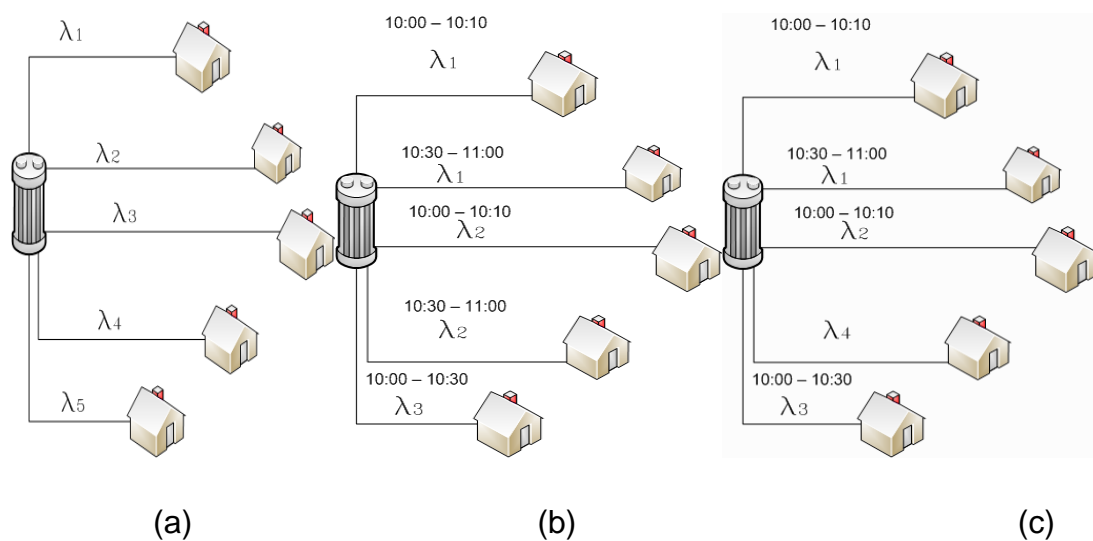

Figure 5- 1: Different wavelength assignments scheme (a) static (fixed) (b) dynamic and (c) hybrid scheme.

The dynamic wavelength assignment (DWA) scheme assigns a wavelength to destinations based on the required data transfer, thus allowing each wavelength to be assigned to different targets at various times [2]. Therefore, it utilizes the network resources in a more efficient way. In this scheme, it needs just two wavelengths to serve three calls described above.

It uses (λ_1) to serve call from the optical transmitter to the first house at a specific time say 10:00 to 10:10 and uses also (λ_1) to serve call from optical transmitter to the second house at another time say 10:30 to 11:00 (figure 5.1 b). That will minimize number of used wavelengths in an optical network. The dynamic wavelength allocation (DWA) is one of the best solutions for the high data rate and high bandwidth, which the wavelength division multiplexer (WDM) can provide.

The hybrid wavelength assignment (HWA) scheme is basically a compilation of these two schemes (static and dynamic). Some destinations have a fixed wavelength (uses (λ_4) house 4) and other houses use dynamic wavelengths (figure 5.1 c).

There are different (DWA) types according to the assignment schemes (centralized and distributed). In the centralized DWA (figure 5.2 a) there is a single controller selecting a wavelength in the cell, and the disadvantage with this scheme is the enormous amount of computation and communication which makes it impractical.

For a new call, a free wavelength from the central pool is selected that would maximize the number of members in its co-wavelength set and minimize the mean square of distance between cells using the same wavelength. In centralized control, requests arriving at each node have to be sent to the centralized operation server and will be processed and served one by one [3].

That is depending on the queuing discipline carried out at the centralized point. The benefit of using centralized scheme is easy to manage and process all network resources and it is convenient to monitor the present status of the network. However, the optimization procedure for some performance of different parameters in the network can be activated at any time for some performance or cost considerations.

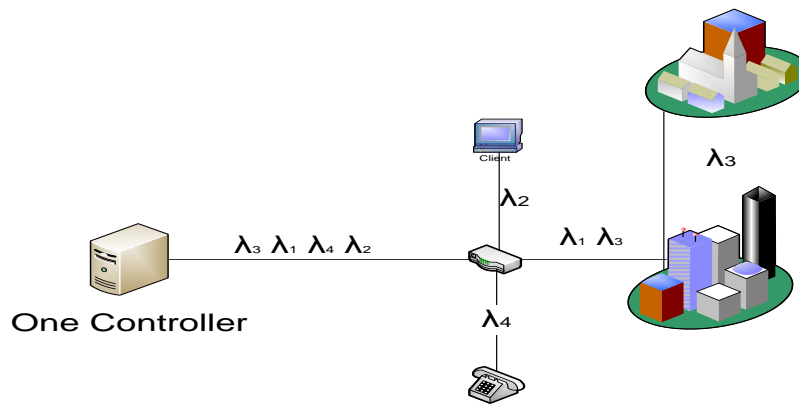

(a)

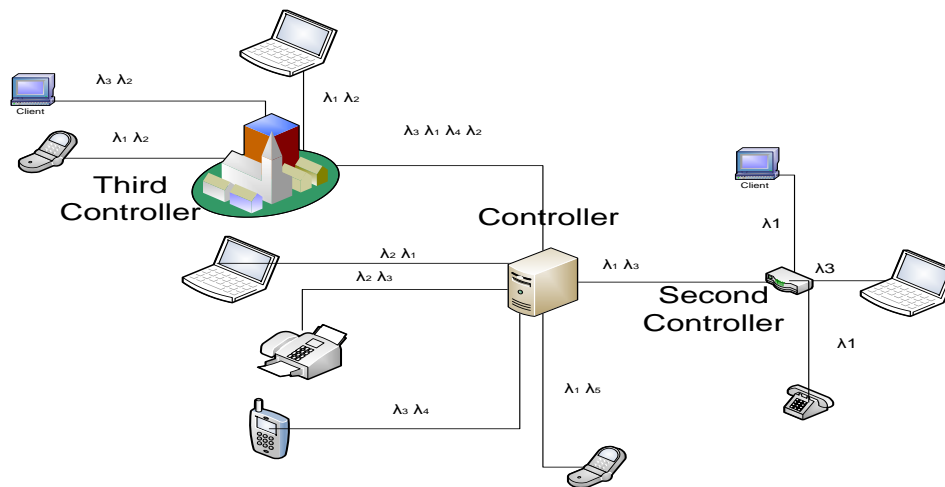

(b)

Figure 5- 2: Different wavelengths assignment types (a) centralised (b) distributed.

In the distributed DWA there are many controllers in the cell or the controllers are spread in all nodes or some of them (sparse). The distributed DWA has advantages of shorter delay and disruption period, simpler implementation, less computational complexity; any problem can affect one node not the whole network and it is easier to fix problems. In the distributed DWA scheme, the controllers in the network nodes expand and the status is collected by messages from and to the neighbours of each node. That will help controllers to process locally orders in a short period of time [4].

Each one of the wavelength assignment schemes has different algorithms to allocate an appropriate wavelength to carry data such as (First Available, Randomly, Locally Optimized, Most Usage, Least Usage, and Mean Square) [5].

Moreover, the advantages of the distributed wavelength allocation scheme are the wide bandwidth of the link (fibre), the huge degree of wavelength modulation utilises the network more efficiently with high and definitive reliability, and the ability to provide high quality of service among modules and nodes. [6]

The distributed computation scheme is significantly maximizing network flexibility. Distributed nodes usually adopt on-line path computation algorithms. In this case, the path is computed by the transmitting node which determines a few paths to the receiving nodes taking into account both links metrics and administrative constraints. [7]

5.1.1 Local and Metropolitan Networks

Local area network (LAN) and Metropolitan Area Network (MAN) are the family of IEEE 802 standards. LAN is described as the network that connects devices in a single office, warehouse or even different buildings in a campus or block. It provides a medium to high data rate, short delays such as few milliseconds or less. It serves distances of at least 2 km and up to few tens of kilometres [8].

MAN is a network that serves several blocks and buildings to complete cities such as London, Par. That means it provides and connects diverse local networks. Wavelengths used in MAN have a medium to high data rate providing various integrated telecommunication traffic such as videos, voices and data, while it supports different devices including bridges, routers, gateways, terminals ...etc. [9]

The Physical layer of MAN supports the ability of receive and transmit modulated signals assigned to various wavelengths, in case of broadband or to a single wavelength band, in the case of baseband using time division multiplexing (TDM). It serves stations at distances as far as fifty kilometres. Many LAN can be connected together to the MAN using a switch which can filter out traffic not intended for the neighbouring network to reduce the amount of the flowed traffic. [10]

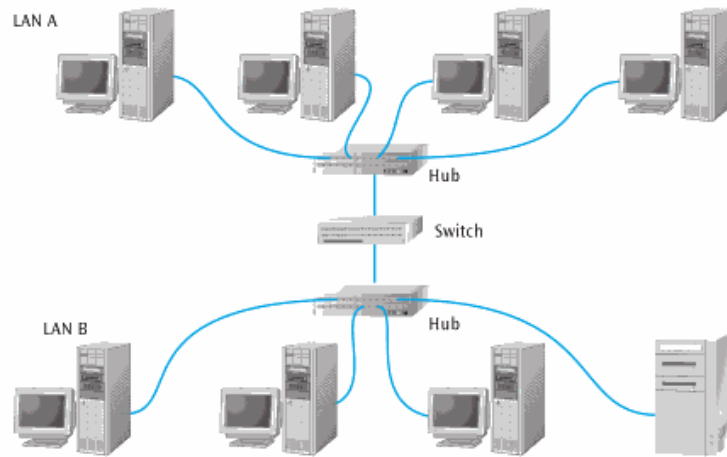

Figure 5- 3: Two LAN connected by a switch

5.1.2 Single and multimode fibres

Optical fibre is a very thin wire that made of glass and its diameter is about one-tenth of millimetre 0.1 mm [11]. Optical fibres can be divided into two classes based on their modal properties single-mode fibre and multimode fibre. Single-mode fibres are step-index while multimode fibres are step- or graded –index, which depend on index of refraction with radial distance from the fibre index [12]. Even though the cost of copper is low, but with the huge demand of the wide bandwidth and high speed for long distances, has meant that copper can't serve these requirements, because of its low bandwidth and slow speed (up to 6.3 Mbit/s). However, single-mode optical fibre has been proposed to overcome the difficulties of the copper used to transmit data for 10 – 20 km at 1300 and 1550 nm with better transmission characteristics than at 850 nm.

The 1300nm and 1550 nm have the lowest attenuation compared with the other wavelengths to transmit data over longer distances. For long distances of up to 50 km, single-mode is utilized while multimode fibre is used for short distances of up to 2 km [13].

The single-mode fibre planes to carries much wider bandwidth at 1300 nm. At the end of 1982, the single-mode fibre has been used to transmit 400Mbit/s at 1300 nm. However the cost of the optical fibre has reduced its use to much longer distance than copper wires. At that time, it is used even for short distances in military agencies.

Engineering has taken care of manufacturing planes with non-metallic airframes to avoid electromagnetic interference from enemy radars. That led to install fibres in the

Marine Corps AV-8B Harrier jet. Moreover, optical fibre has been utilized in radar installations because of its low attenuation and the high speed especially for the radar dish which is far from the control centre.

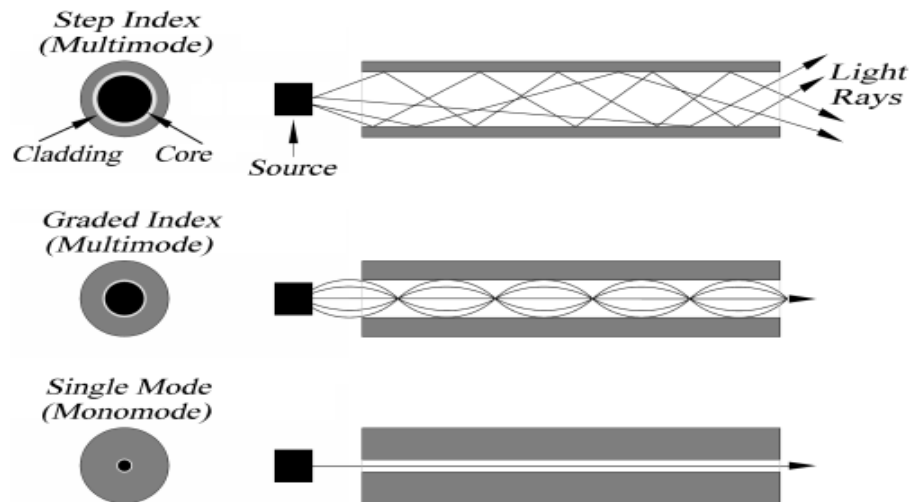

Figure 5- 4: Single-mode and multi-mode fibre types [14]

The total attenuation for the three wavebands 850 nm, 1300nm and 1550 nm in optical fibre are <2, <0.5 and <0.2 dB/km. although the wavelength 1550 nm has the lowest losses, but the wavelength 1300 nm has zero dispersion for dispersion non-shifted single-mode fibre [15].

5.1.3 Why Optical Fibre?

Optical fibre has made a revolution in data transmission because of its characteristics that made it suitable for various services. Some of the reasons of using optical fibre are listed below: [16]

- Its high speed to transmit data for a much longer distance than copper wire;
- It has huge bandwidth to transmit many signals in the same fibre;
- The low attenuation of the optical fibre has made it first choice to send data;
- Inviolability to electromagnetic intervention;
- It cannot be tapped simply because of its data security;
- The optical fibre could be easily Non-conductive;
- Danger of spark is not expected as opposed to copper wires;

5.1.4 Refraction

Refraction can be defined as the change of direction of any wavelength which can occur when the speed of the wavelength changes as it passes from one medium to another in a non-straight angle [17].

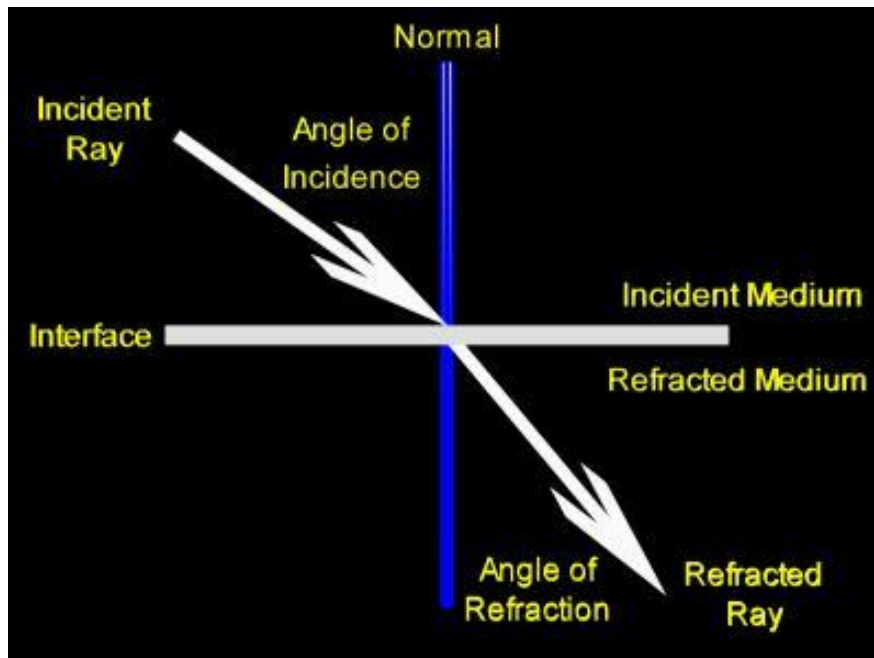

Figure 5- 5: Refraction in various medium [18]

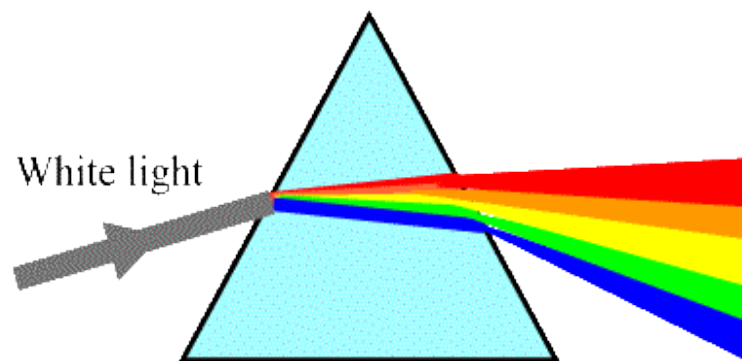

Figure 5- 6: Refraction through a Prism [19]

5.1.5 Factors Governing Refraction

The amount of refraction of light at a boundary between two media depends on three things [20]. **The nature of the media (embodied in a characteristic quantity called the *index of refraction* for a medium).**

1. The angle of incidence for the light ray on the boundary.

2. The wavelength of light.

The short wavelength travel faster than the long wavelength [21], therefore the work in this chapter concentrates on assigning the shortest wavelength in the proposed algorithm.

5.1.6 Refractive Index (n)

The refractive index (n) of a material is the ratio of the speed of light (c) in a vacuum to the velocity of light in the material (cS) [22]. Refractive index equation is as below:

$$n = \frac{c}{v} \quad (5.1)$$

(n) refractive index

(c) light speed in vacuum

(v) electromagnetic speed in the material

The refractive index of a material is always greater than 1.

For example; water = 1.33, diamond = 2.42, glass = 1.5, air = 1.

According to the refractive index equation (4.1), the refractive index of the air is 1 because the speed of light in free space it equal to the speed of light in air ($c = v$). While in optical fibre or glass the speed is about ($2 \times 10^8 \text{ m/s}$) and light speed in free space is ($3 \times 10^8 \text{ m/s}$). Therefore, refractive index calculated as shown below:

$$n = \frac{c}{v} = \frac{3 \times 10^8 \text{ m/s}}{2 \times 10^8 \text{ m/s}} = 1.5 \quad (5.2)$$

While the speed of the wave depends on the angular frequency in the formula:

$$v = \frac{\omega}{k} \quad (5.3)$$

where,

(ω) is the angular frequency

(k) is the propagation constant (each material has a certain propagation constant)

The time needed for wave to travel in a medium is: [23]

$$t = \frac{n \cdot L}{c \cos \theta} \quad (5.4)$$

$$t = \frac{c L}{c v \cos \theta} \quad (5.5)$$

$$t = \frac{L}{v \cos \theta} \quad (5.6)$$

(c) is light speed in free space

(v) is light speed in the material

(n) is refractive index of the material

(L) the length of the fibre

(θ) is the angle of the wave with the y-axis

5.1.7 Dispersion

Dispersion is the separation of a complex wave into its component parts according to a given characteristic, such as frequency or wavelength. The separation of electromagnetic radiation into constituents of different wavelengths simply limits the light propagation along the fibre. [24]

Dispersion value is related to the second derivative of the propagation constant (β) [25]

$$D = \frac{-2\pi c}{\lambda^2} \frac{d^2\beta}{d\omega^2} \quad (5.7)$$

$$\frac{d^2\beta}{d\omega^2} = \frac{1}{c} \left(2 \frac{dn_e}{d\omega} + \omega \frac{d^2n_e}{d\omega^2} \right) \quad (5.8)$$

$$\beta = k_0 n_e \quad (5.9)$$

$$k_0 = \frac{\omega}{c} = \frac{2\pi}{\lambda} \quad (5.10)$$

$$n_e = \Delta n_e + n_0 \quad (5.11)$$

$$D = \frac{-2\pi c}{\lambda^2} \frac{d^2 k_0 \Delta n_e}{d\omega^2} + \frac{-2\pi c}{\lambda^2} \frac{d^2 k_0 n_0}{d\omega^2} = D_{\text{waveguide}} + D_{\text{material}} \quad (5.12)$$

(c) is light speed

(β) is propagation constant

(ω) is angular frequency

(n_e) is effective index

(k_0) is free space wave number

(λ) is wavelength

(n_0) is refractive index of the cladding

Fibre dispersion can be categorized into material (intermodal) dispersion and chromatic dispersion. Material (intermodal) dispersion is caused by the fact that different propagation modes in a fibre travel at different speeds. Usually a large number of modes coexist in a multimode fibre; therefore intermodal dispersion is the major source of dispersion in multimode fibres.

Chromatic dispersion is originated from the fact that different frequency components in each propagation mode may travel at slightly different speeds and therefore it is the dominant dispersion source in single-mode fibres. Both intermodal dispersion and chromatic dispersion may cause optical signal pulse broadening and waveform distortion in fibre-optic systems. [26]

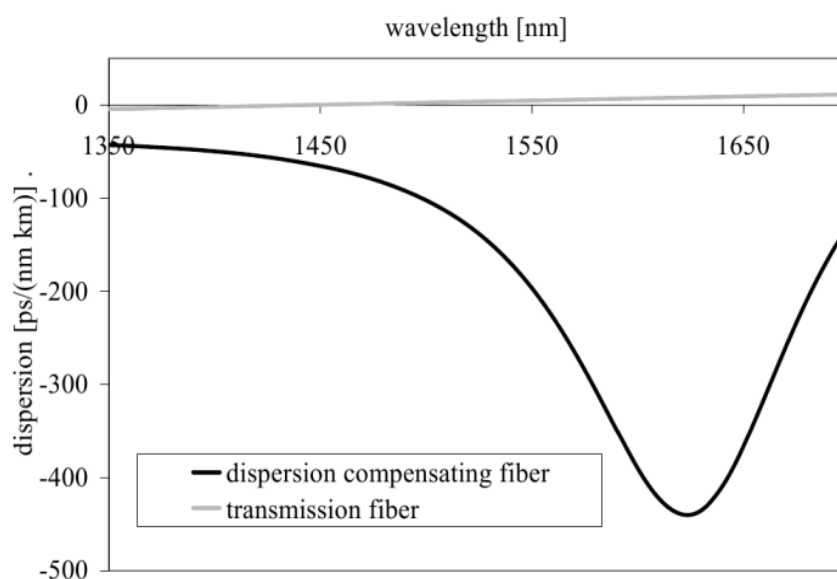

Figure 5- 7: Dispersion for different wavelengths for transmission fibre and the dispersion compensating fibre

5.2 Dispersion of Various Wavelengths

There are various terms can reduce and effect dispersion. Firstly high data rate can highly harm and deform a signal more than low data rate. Secondly dispersion coefficient (D) can be reduced by manufacturing fibres with low material dispersion. Thirdly, minimizing spectral width (B) can reduce dispersion that can occur by using an LED that has a spectral width of 50 nm. Fourthly, using wavelengths that have low dispersion can decrease dispersion also. Another method to reduce dispersion for specific wavelength is by using dispersion-shifted fibre, which has a zero dispersion wavelength at 1550 nm (figure 5.8).

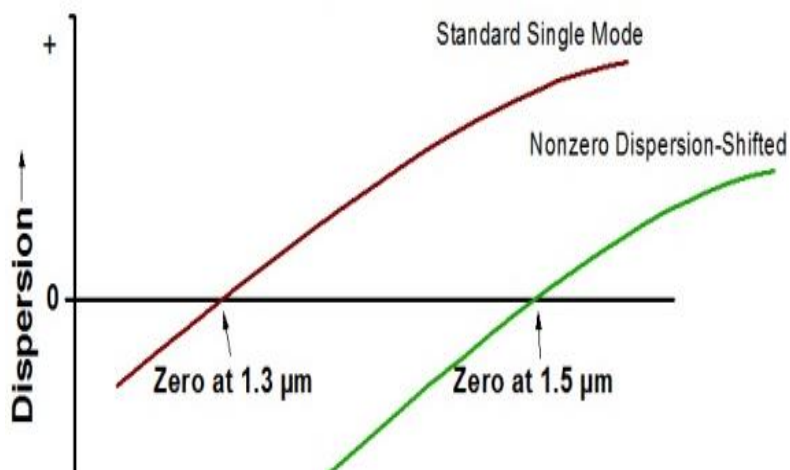

Figure 5- 8: Stander and dispersion shifted [27]

The advantage of this fibre is its zero-dispersion at wavelength 1550 nm which has the minimum value of attenuation 0.2 dB/km. However, the dispersion-shifted fibres have particular faults such as they cause more crosstalk among neighbouring wavelengths in WDM applications fibre [28]. The last method has been adopted in this chapter.

The dispersion has different values for various wavelengths. The VPI software has been used to find the effect of using wavelengths from four bands (O, E, S and C bands) which have been described below: [29]

- I. O-band (original) – A range from 1260 nm to 1360 nm
- II. E-band (extended) – A range from 1360 nm to 1460 nm
- III. S-band (short wavelength) – A range from 1460 nm to 1530 nm
- IV. C-band (conventional) – A range from 1530 nm to 1565 nm

To find the dispersion values for several wavelengths the optical fibre used is original optical fibre with zero-dispersion at 1300 nm. That means the implemented network is without using dispersion-shifted optical fibre, which is called non-shifted optical fibre. The length of the fibre used is 10 km which is the average length of the metropolitan area networks (MANs).

The Impulse Generator (Optical) has been used to produce and send pulses with diverse wavelengths (1550, 1530, 1510, 1490, 1470, 1450, 1435, 1420, 1405, 1390, 1375, 1360, 1345, 1330, 1315 and 1300 nm). This module generates an optical delta pulse, which lasts a single sample period. It can be used for testing the temporal response or spectral response of optical fibres [30]. The peak power of the impulse generator is set to ($1 * 10^{-3}$ W) and the data rate is (10^9 bit/s).

The length of the used optical fibre is (10^3 m), the refractive index is 1.47 non-unit, attenuation is ($0.2 * 10^{-3}$ dB/m) and the central wavelength is 1300 nm.

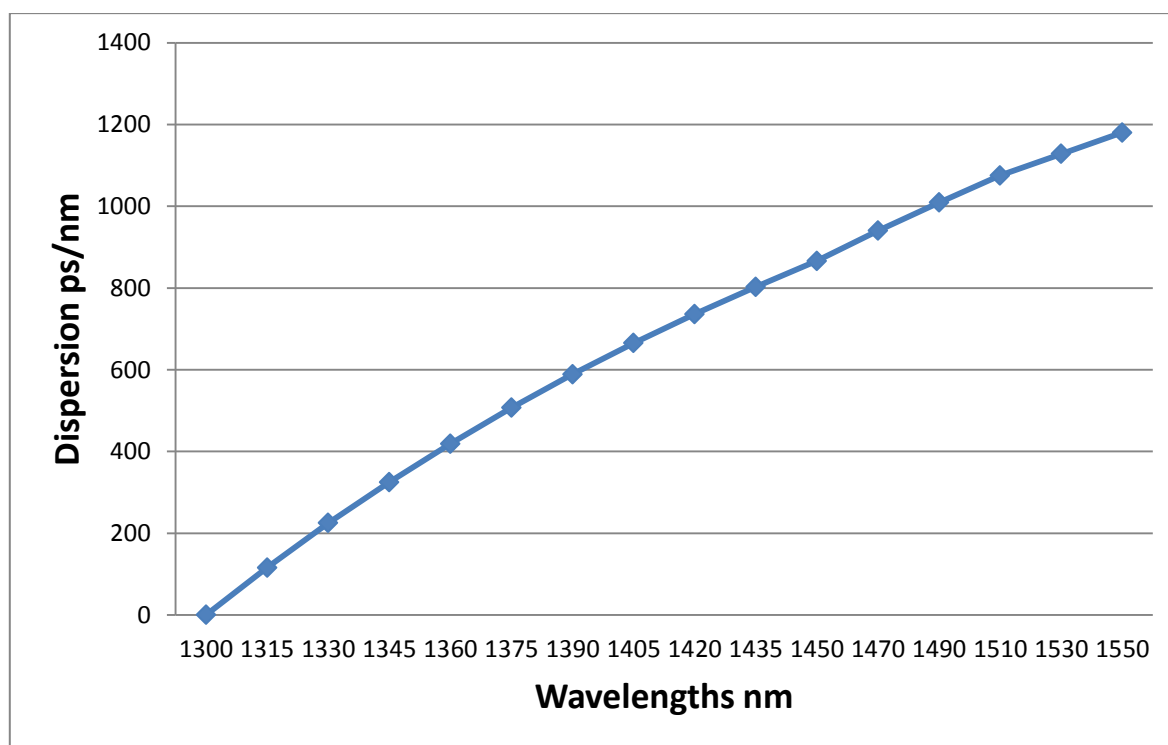

Figure 5- 9: Dispersion for various wavelengths

As it is clear that wavelength 1300 nm has zero-dispersion in the optical fibre, dispersion is increased when the wavelength is maximized. It is varied from zero ps/nm up to 1200 nm/ps at 1550 nm. Total dispersion (material (intermodal)

dispersion and chromatic dispersion) is degrading the performance of the speed of the wavelength in optical fibre communication and transmission.

Either negative or positive dispersion results in pulse expansion of the transmitted wavelengths. The expansion occurs because the dispersion is increasing when the length of the fibre is longer, which forces a limitation of the maximum distance and data rate without a regeneration process. [31]

Therefore this work has adopted the idea of minimizing dispersion by choosing the shortest wavelength. By assuming the shortest wavelength in this work is zero-dispersion 1300 nm, this will help to reduce dispersion at the end clients.

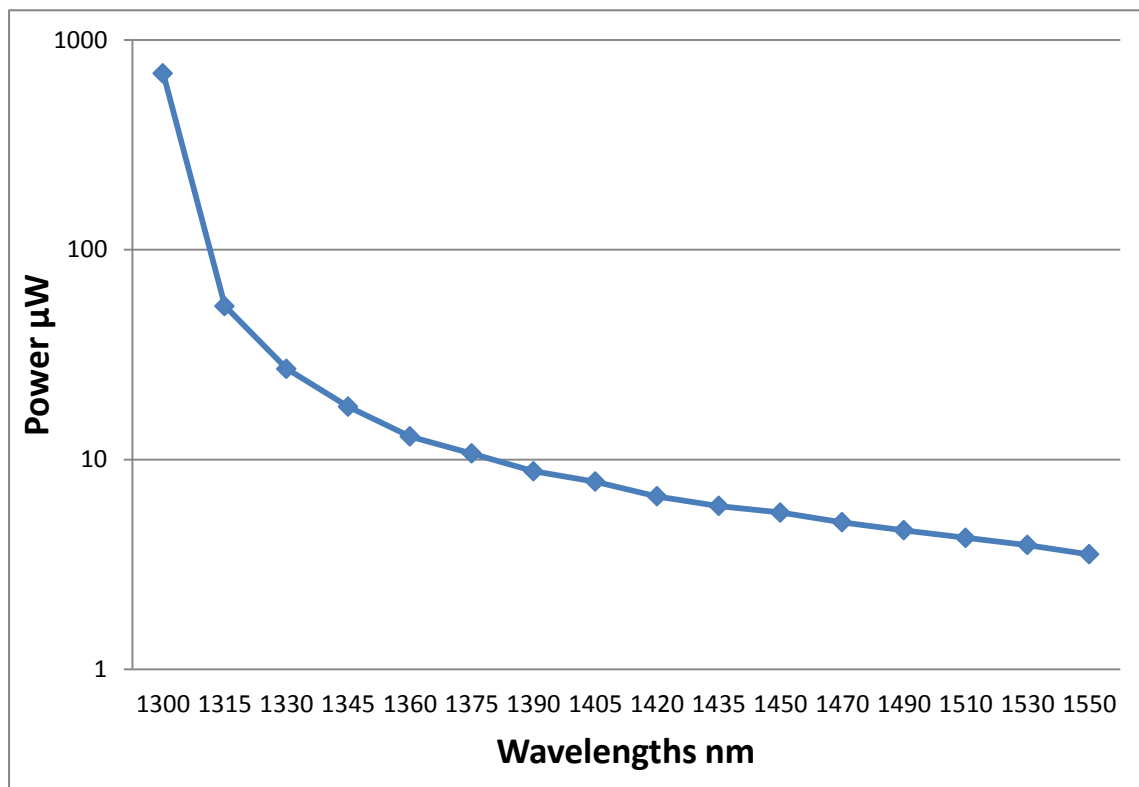

Figure 5- 10: Power for various wavelengths

Wavelengths have different energy themselves. According to the equations below, it can be obvious that the energy is inversely proportional to the wavelength. Since the power of the signal is presented in equation (5.13) and it is dependent on the energy, it can be seen that the power of the signal is inversely proportional to the wavelength of the signal as presented in equation (5.15). [32]

$$P = \frac{E}{t} \tag{5.13}$$

$$E = \frac{h * c}{\lambda} \tag{5.14}$$

$$P = \frac{h * c}{\lambda * t} \tag{5.15}$$

(*P*) is power of the signal

(*E*) is the energy of the signal

(*t*) is the time

(*h*) is the Planck's constant ($6.626 \times 10^{-34} J.s$)

(*c*) is the speed

(λ) is wavelength

The end clients can get high quality of service when they receive a high power of the transmitted signal. Since the power of the signal is strong for the short wavelengths, therefore, the chosen wavelength in this work is the shortest wavelength. As the shortest wavelength used is 1300 nm, so this work concentrate on choosing the shortest wavelength to 1300 nm.

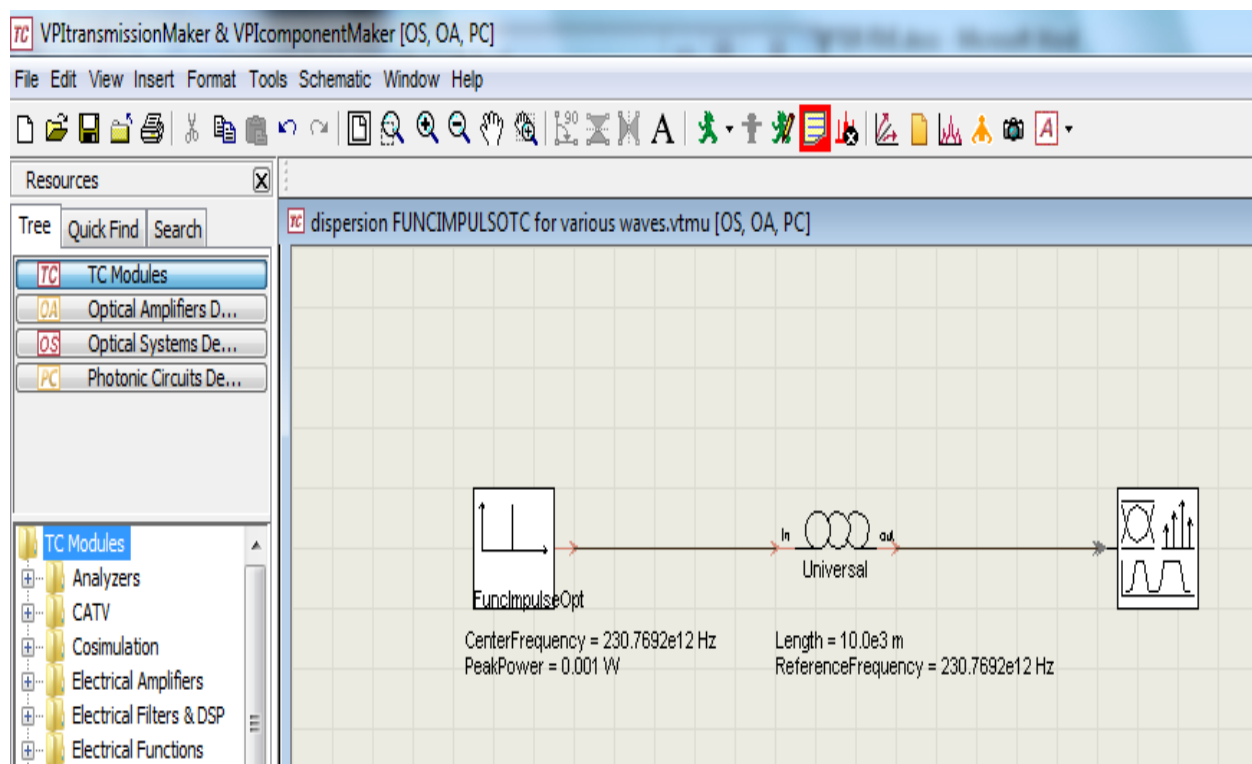

Figure 5- 11: Analysing wavelengths through 10 km optical fibre

The simple module as shown above is implemented to investigate the effect of the supplied power. The FuncImpulseOpt (function of optical impulse) is set to transmit an impulse with wavelength at 1300 nm. It has transmitted this wavelength through 10 km optical fibre with different power values. It starts with 0.0001 W and this is varied to 0.001, 0.01, 0.1, 1 and 10 W. By increasing supplied power of the FuncImpulseOpt, the analyser shows that the dispersion has been decreased by a significant value from (0.12 ps/nm) to about (0.000713 ps/nm) at 0.0001 and 10 W respectively. The figure below shows that the dispersion is inversely proportional to the supplied power. Therefore using the high power wavelengths produce lower dispersion.

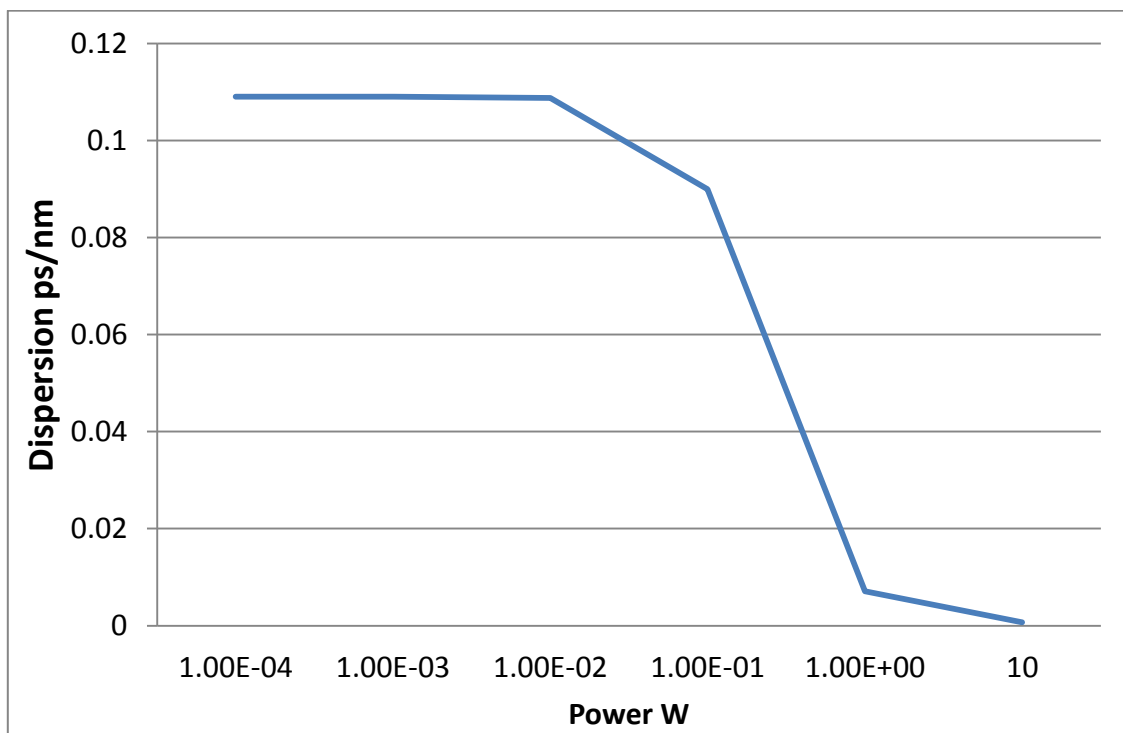

Figure 5- 12: Dispersion for various supplied power values

The other benefit can be obtained from the investigation of the various values of power, is its effect on the group delay (GD). The power has decreased group delay by a high value. GD is reducing from about (0.1 ns) to about (0.001 ns) at 0.0001 and 10 W respectively as shown in figure 5-13 below. Therefore, this work has taken this advantage to minimize GD as much as possible.

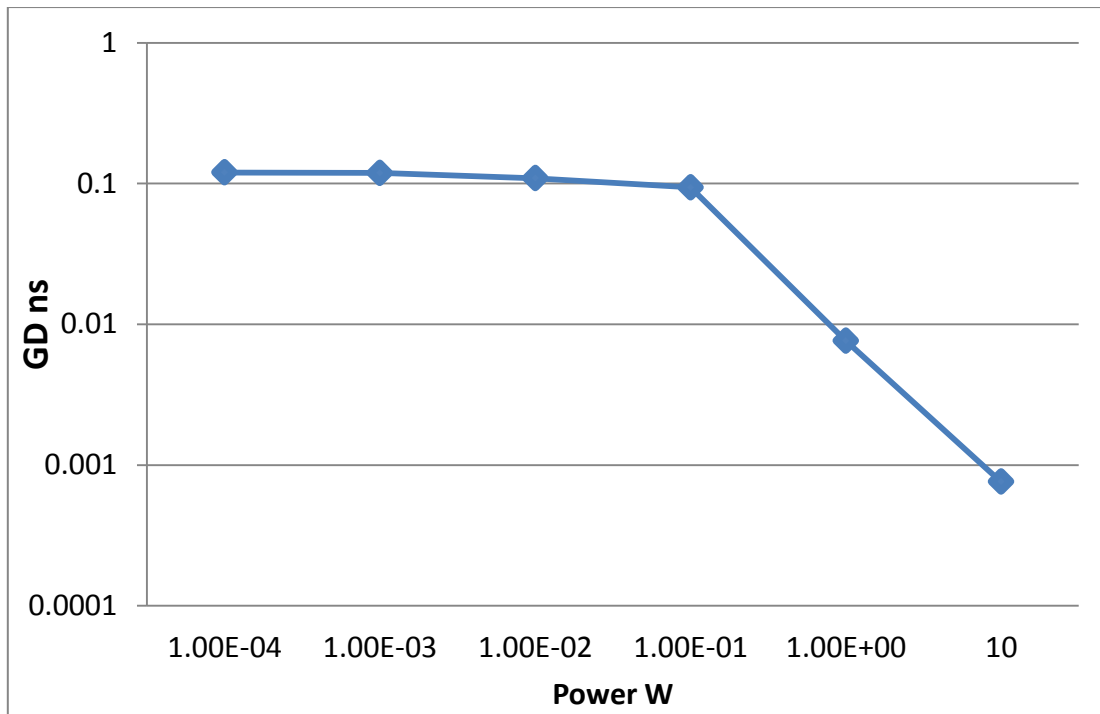

Figure 5- 13: Group Delay for various supplied power values

	10km	30km
1300	3.5e6 ps/nm	6.12e6 ps/nm
	1.543 ns	3.19 ns
	1.628 W	210.89e-3 W
1550	3.66e6 ps/nm	6.13e6 ps/nm
	1.545 ns	3.2 ns
	1.626 W	210.76e-3 W

Table 5- 1: Dispersion, Group Delay and Power for 10 and 30 km at 1300 and 1550 nm

To implement our network, we have to investigate the effect of the distance on the output wavelengths. The distance of 10 km and 30 km has been implemented using two different wavelengths (1300 nm and 1550 nm). According to the table above that shows the advantage of using short wavelengths can be acceptable until about 30 km. The GD is about the same at both wavelengths at different distances while the power is slightly different. However the significant difference is in dispersion which is varied from (3500000 ps/nm) to (3660000 ps/nm) (reduction is 160000 ps/nm) at 1300 nm and 1550 nm respectively at 10 km, while the difference is reduced to 10000 ps/nm at 30 km. Therefore, the maximum distance adopted in this work is 30 km.

5.3 State of art

The wavelength multicast in tree networks has been investigated in [35]-[39]. In [35] they studied wavelength assignment for WDM multicast to minimize the wavelength costs. Work in [36] proposed two improved virtual source based algorithms that constructs all-optical multicast trees (nodes have splitter and converter).

Their results show that their mechanism builds light-trees with the least wavelength channel cost and with the smallest number of wavelengths under certain number of multicast sessions.

They proposed in [37] novel two tree construction algorithms. Since the proposed tree algorithms take account of the number of wavelengths available for each link, this algorithm can select those links which have larger number of available wavelengths.

Chatterjee, Sarma, and Sahu [38] proposed an advantage of based on dispersion-reduction wavelength allocation (PDRWA) algorithm to minimize the total dispersion in the optical fibre network. In this scheme, the connection requests having a same source-destination (s-d) pair are groomed first to avoid intermediate (O/E/O) conversation. Then these sponsored connection requests with wavelengths having a higher dispersion, are assigned to the light- paths with shorter distance and longer light-paths are assigned the wavelengths having lesser dispersion.

Moscholios, Logothetis, Stylianakis and Vardakas [39] have analysed and proposed three algorithms for dynamic wavelength assignment in a WDM-TDMA PON, by separately considering random or quasi-random input-traffic. They concentrate on choosing a random scheme to avoid time processing for wavelengths allocation.

5.4 Wavelength assignment algorithms

WDM has made a revolution in the optical fibre networks by increasing number of transmitted wavelengths into fibre optics. They can reach 160 wavelengths [33] which is a huge number compared with the single wavelength that has been sent in the beginning of optical fibre manufacturing. While it can be feasible to have hundreds of wavelengths per fibre where each wavelength can carry about 40 Gb/s. [34]

Even if the number of wavelengths is huge in WDM, it has to be processed carefully and selected by an appropriate algorithm. There are several methods to allocate wavelength to operate data transmission to clients.

Wavelength assignment algorithm proposed in this chapter concentrates on maximizing the signal power and minimizing dispersion on the received wavelength. The explained algorithms in this work are about multicast technology when the same data or calls are sent to multi-destinations.

5.4.1 Multicast Wavelength Assignment Algorithm (MWAA) [40]

This multicast algorithm is proposed in [40] and they have proposed multi and uni-wavelength assignment. The uni-wavelength assignment is called $k=1$. It allocates the input wavelength which is available on the output. If the input wavelength is not available on the output, then it appropriates the wavelength randomly.

5.4.2 New Greedy Wavelength Assignment (NGWA) algorithm [41]

The NGWA wavelength assignment algorithm is used to minimize wavelength conversion. The algorithm allocates wavelength in two steps; the first step is called a partial step and the second step is called complete step. In the partial step, it assigns the available wavelength in the maximum output links using the bottom to top method. If there is more than one wavelength, it allocates all the candidate wavelengths. In the complete step, it allocates the wavelength that has the most-used scenario in the whole network. If the wavelengths do not feed all destinations, the NGWA algorithm chooses any wavelength randomly to reach the destinations.

5.4.3 Shortest Wavelength Assignment (SWA) algorithm

To select a specific wavelength to carry data or calls from source to different destinations, it needs a certain algorithm for the wavelength selection processing. One of the two proposed algorithms in this chapter is to allocate the shortest wavelength available that is to decrease dispersion, GD and increase the signal power. The available wavelengths can be varied to different destinations.

The SWA algorithm selects the shortest wavelength which is 1300 nm or the nearest one to this wavelength. If there are more destinations available, it chooses another wavelength which is the nearest one to the 1300 nm.

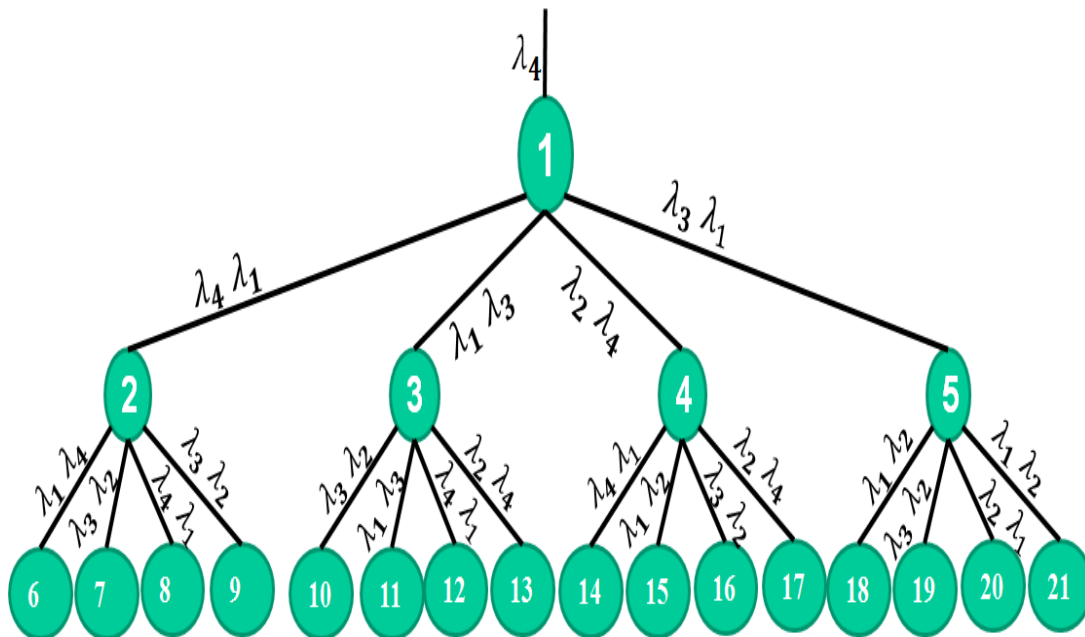

Figure 5- 14 : Quaternary tree with various wavelengths to different destinations

The quaternary tree with two levels is illustrated in figure (5.14). There are four wavelengths implemented in this network

($\lambda_1 = 1300, \lambda_2 = 1350, \lambda_3 = 1450$ and $\lambda_4 = 1550$ nm) and assumed to be two random wavelengths available to each destination. The shortest wavelength assignment (SWA) algorithm is choosing shortest wavelength in the first step.

In the second step, if there are more destinations that need feeding, it selects the second shortest wavelength and so on until all destinations receive the transmitted data. The wavelengths will be allocated as shown in figure (5.15).

The tree network is defined as a table

$\lambda_{in}=1550$	Dest. 1	Dest. 2	Dest. 3	Dest. 4
λ_1	1	1	0	1
λ_2	0	0	1	0
λ_3	0	1	0	1
λ_4	1	0	1	0

Table 5- 2: quaternary tree as a table

Algorithm: *shortest wavelength allocation*

Constant: *width (number of wavelengths), length (number of destinations)*

Input: *multicast tree, input_wavelength*

Output: *assigning wavelength*

Begin

For $n=1$ to width do

Find shortest wavelength;

Assign the shortest wavelength;

Remove the assigned wavelength's destinations;

Repeat for all remaining destinations;

End for

End

It is a simple algorithm and there is a quick time for processing because there are not many choices. It has to select the shortest wavelength and it is one wavelength in all situations not like other algorithms which need to compare among several wavelengths and then choose one of them as shown in the two algorithms above.

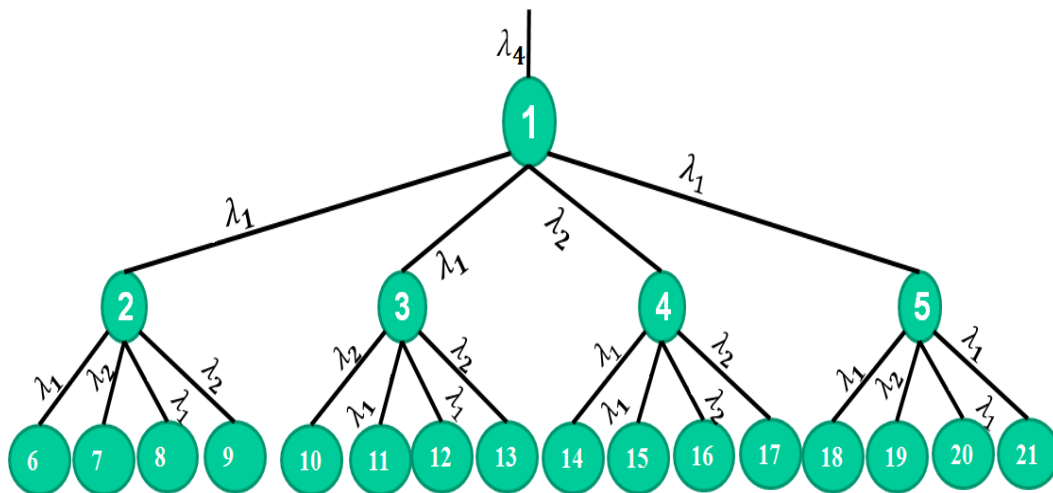

Figure 5- 15: Quaternary tree network with shortest wavelength assignment (SWA) algorithm

5.4.4 Highest Number of Destinations with Shortest Wavelength Assignment (HND-SWA) algorithm

There are some disadvantages (which will be analysed in detail in the next chapter) in using the previous algorithm (SWA) such as many wavelengths used to transmit

data and a lot of wavelength conversion which leads to increased number of wavelength converters. The other disadvantage of SWA is the high cost and high power consumption because of the large number of used wavelength converters. To overcome these disadvantages, we propose another algorithm, which combines the SWA and HND algorithms.

HND algorithm selects the wavelength that can reach maximum number of destinations. That wavelength is used to carry data to its destinations. While the multicast is the technology that is used in this work, one or more wavelength/s may be enough for this technology. If one wavelength is not enough the HND algorithm will choose another wavelength that has maximum number of destinations in the remaining available wavelengths and soon until all clients receive data.

There is a situation facing this algorithm when there are two or more wavelengths that have same number of destinations. In this case, the HND algorithm selects a random wavelength while the proposed HND-SWA algorithm makes the selection of the shortest wavelength/s. By using HND-SWA algorithm, the disadvantages of the SWA and HND algorithms are vanquished.

Algorithm: *highest number of destinations with shortest wavelength allocation*

Constant: *width (number of wavelengths), length (number of destinations)*

Input: *multi cast tree, input_wavelength*

Output: *assigning wavelength, number of selected wavelengths, wavelengths converters number*

Begin

For n=1 to width do

Calculate number of destinations for each wavelength

Find wavelength with maximum destinations

If there are two or more wavelengths with the same number of destinations

Choose shortest one

Else

Assign it

End if

Remove the assigned wavelengths destinations;

Repeat for all remaining destinations

End for

End

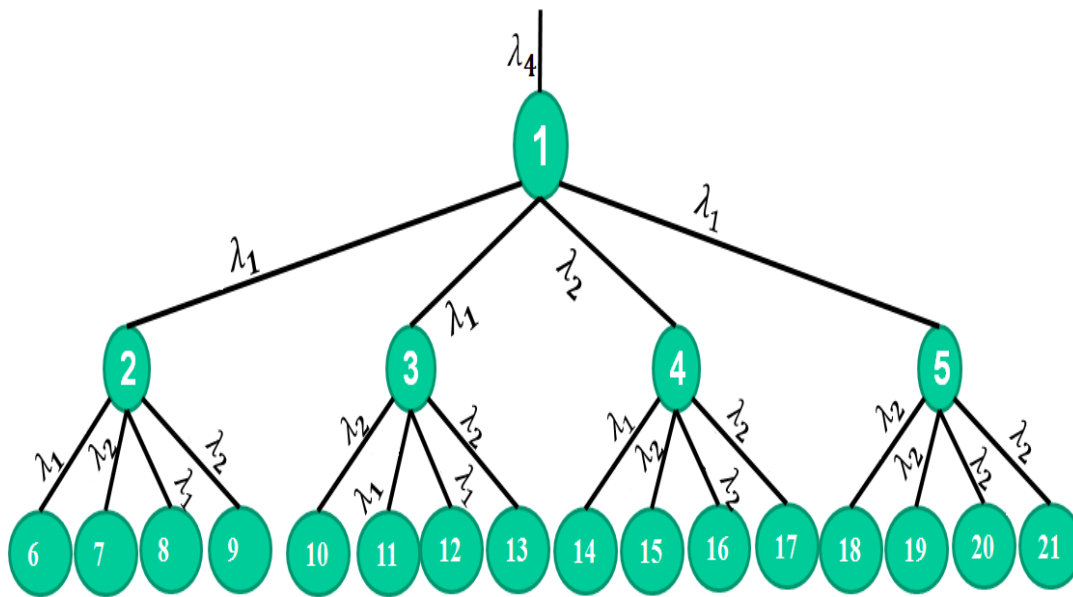

Figure 5-16: Quaternary tree network with highest number of destinations with shortest wavelength (HND-SWA) algorithm

According to the figures (5.15 and 16), the SWA and HND-SWA have a very near performance. They have different wavelength allocation just in node (5) where the SW algorithm selects (λ_1 to destinations 18, 20 and 21 and λ_2 to destination 19) while HND-SWA algorithm chooses (λ_2 to destinations 18, 19, 20 and 21). In that case HND-SWA has slightly higher dispersion and GD compared to the SW. That will be analysed in detail in the results and discussion section.

5.5 Results and Discussion

Various networks are implemented to investigate the performance of the two proposed algorithms compared with two other algorithms. The software VPI photonic is utilized for this examination. The first network is a binary network with three levels. There are one source and the destinations are the leaf nodes and the other nodes in the level one are switches. The optical fibre between each level is 10 km, which means the size of the network is 30 km. The optical fibre used is a standard single-mode fibre (zero dispersion at 1300 nm). The data rate is 10 Gbps which is the medium data rate in this time.

This work concentrates on reducing dispersion at the received wavelength. Moreover, the decrease in group delay is the second goal of this work. Furthermore the work is focused on increasing the signal power at the clients' receivers. Results in figure 5.17 show the performance of the SWA, HND-SWA, MWAA and NGWA algorithms related to the dispersion.

The dispersion has the minimum values at SWA algorithm because it selects the wavelengths that have lowest dispersion values. The HND-SW algorithm has the dispersion values which are very near to the SWA algorithm performance. The other algorithms have concentrated on minimizing number of converters regardless of the dispersion. Therefore their dispersion values are significantly higher.

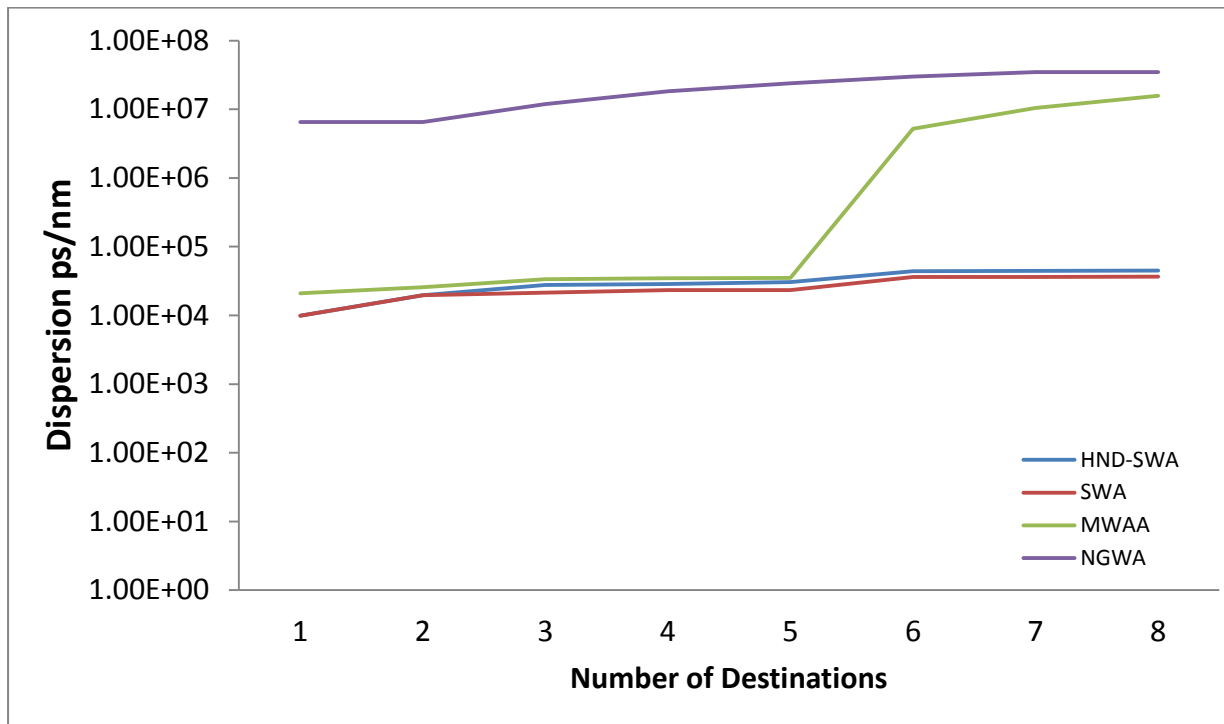

Figure 5- 17: Dispersion for various algorithms in binary network

Group delay results shown in figure 5.18 are for different algorithms. The performance of the SWA algorithm is the best compared with the other algorithms. Although the performance of the HND-SWA algorithm still keeps its performance very near to SWA algorithm, the difference is very small. The GD is inversely proportional on the power of the signal and directly proportional on the wavelength according to the wave equation.

The number of devices that the wave is passing through also affects the GD. The performance of the NGWA algorithm is the worst compared with the other algorithms

because it select wavelengths regardless of their dispersion values. Therefore, the dispersion values of the MWAA and NGWA algorithms are variable.

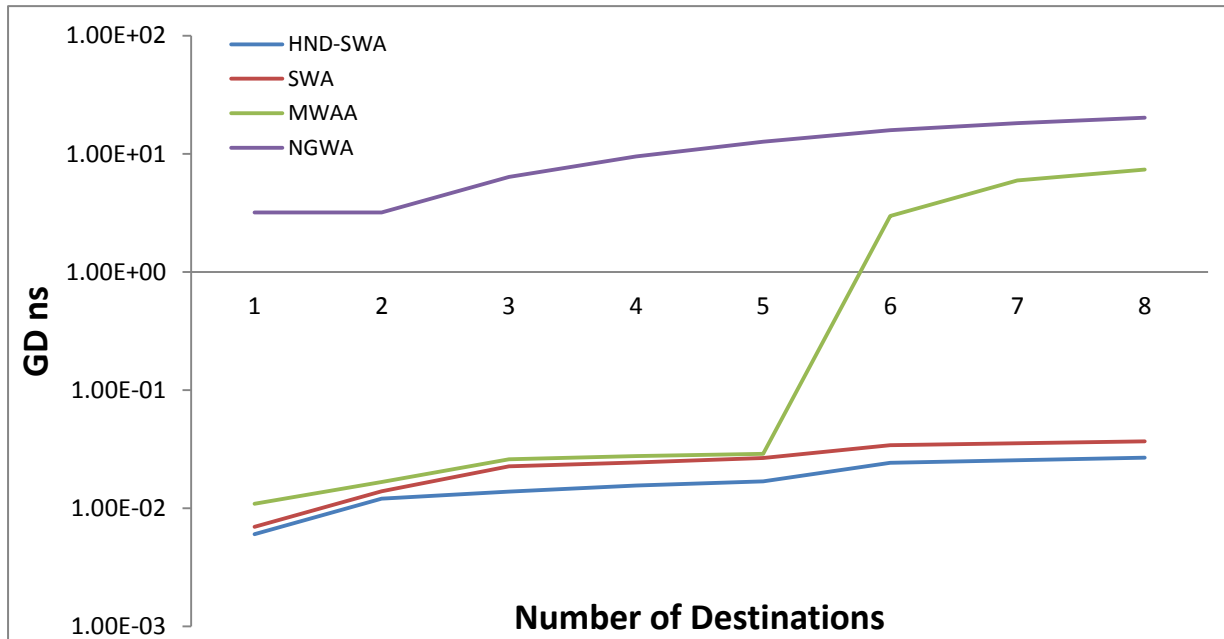

Figure 5- 18: Group delay for various algorithms in binary network

The signal’s power results are illustrated in figure 5.19. The highest power values are recorded for the SWA algorithm which is caused by assigning the shortest wavelengths that have highest power. The HND-SW algorithm has recorded a proportionally high value but it is little bit less than SWA algorithm.

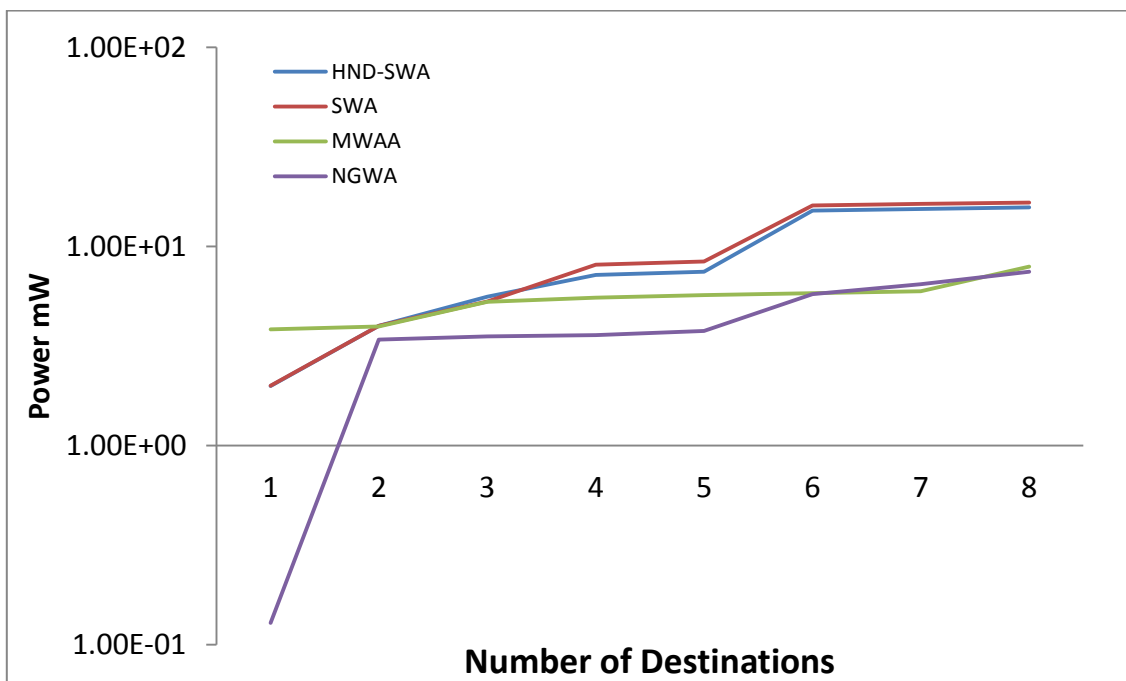

Figure 5- 19: Signal power for various algorithms in binary network

Different wavelengths assignment algorithms are implemented in quaternary tree using VPI transmitter software. The quaternary tree consists of two levels with 20 links; each link has two available wavelengths. The total wavelengths in the network are eight wavelengths feeding sixteen destinations. The distance between each level is 10 km and the total size of the network is 20 km from source to destinations. The wavelengths are placed randomly throughout the links. The data rate is 10 Gbps and the wavelengths used are wideband (1300, 1335, 1370, 1405, 1440, 1475, 1510 and 1550). The S-C-S-C wavelengths multicast switching is used in these algorithms.

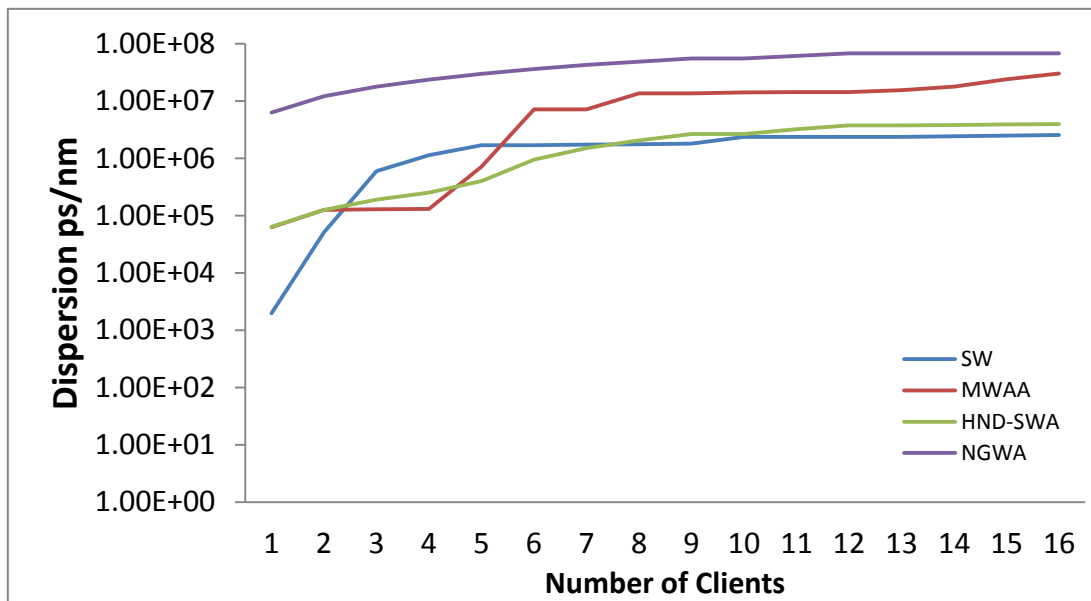

Figure 5- 20: Dispersion for various algorithms in quaternary network

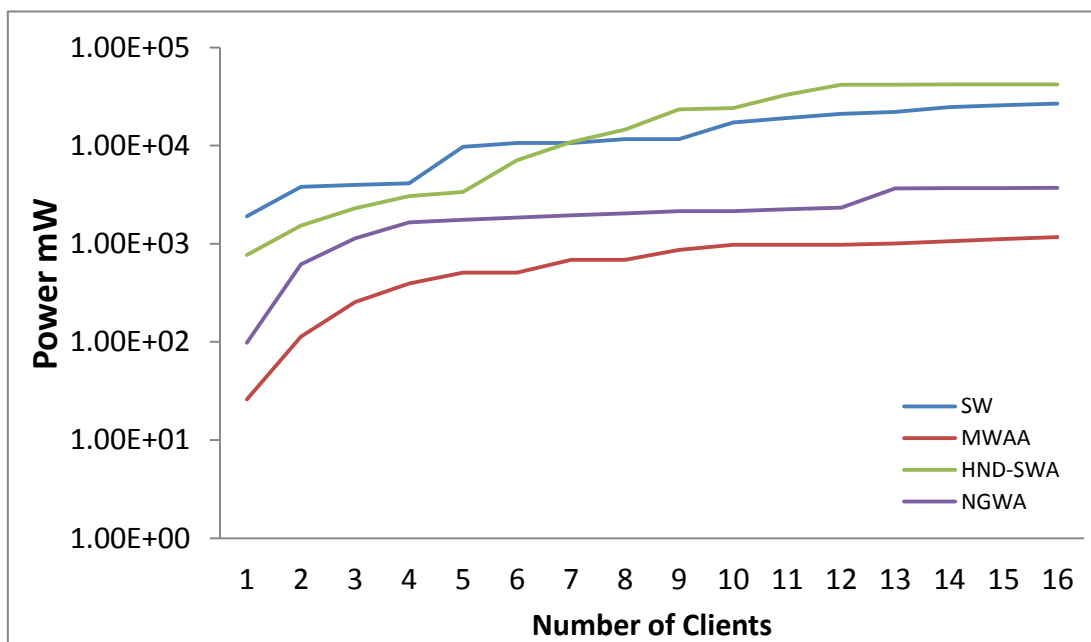

Figure 5- 21: Signal power for various algorithms in quaternary network

The performances of the SWA and HND-SWA algorithms are best among other algorithms. Their performances are about the same relating to the dispersion and power. While the HND-SWA algorithm has better performance than SWA algorithm related to the group delay.

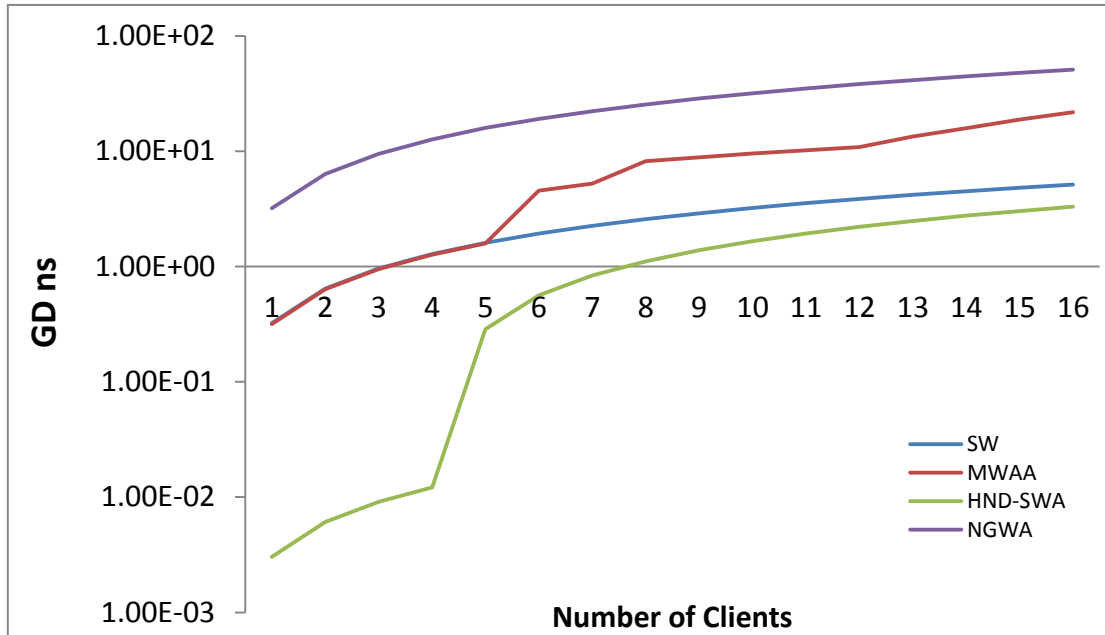

Figure 5- 22: group delay for various algorithms in quaternary network

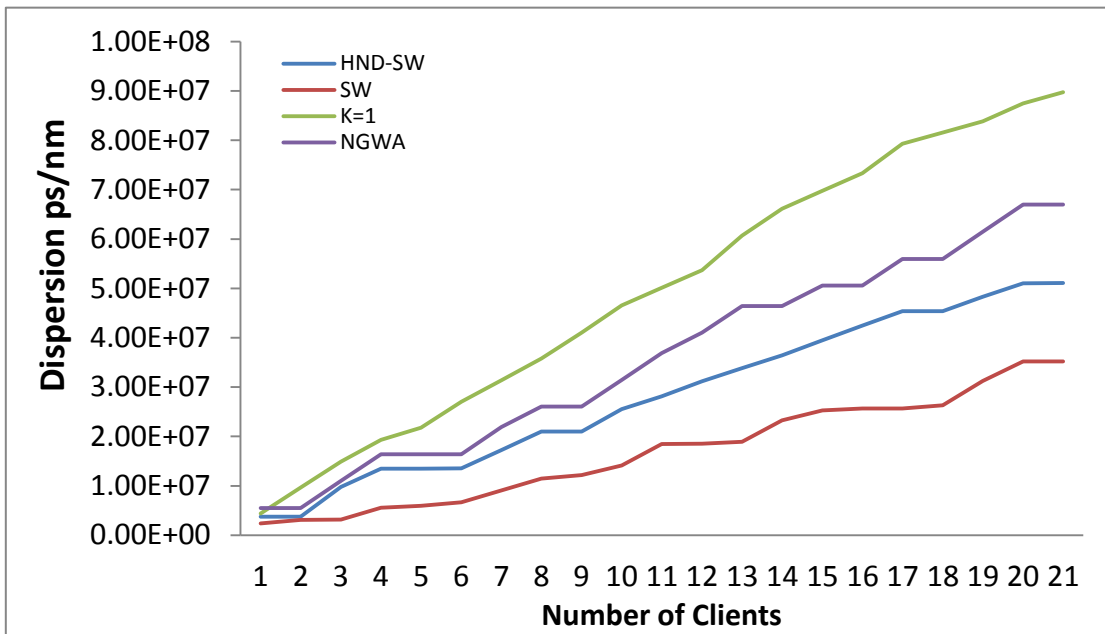

Figure 5- 23: Dispersion for various algorithms in random network

The performance of the proposed algorithms is investigated using different tree topologies. The simulations in figures (5.21 and below) have used symmetric trees to show the values of the dispersion, group delay and signal power of the proposed

algorithms SWA and HND-SWA compared with two other algorithms NGWA and MWAA.

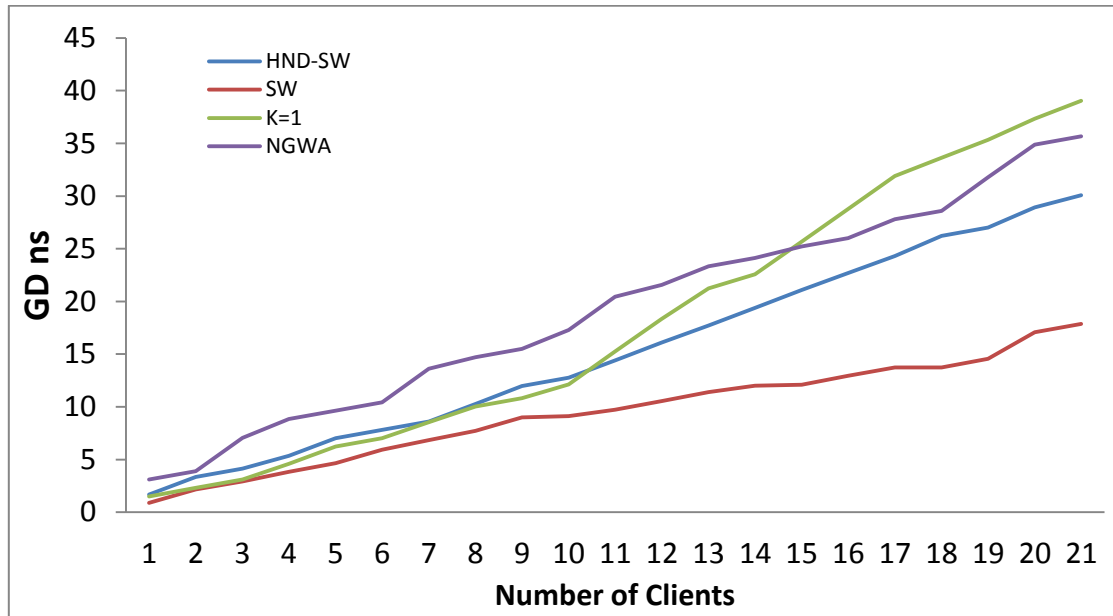

Figure 5- 24: Group delay for various algorithms in random network

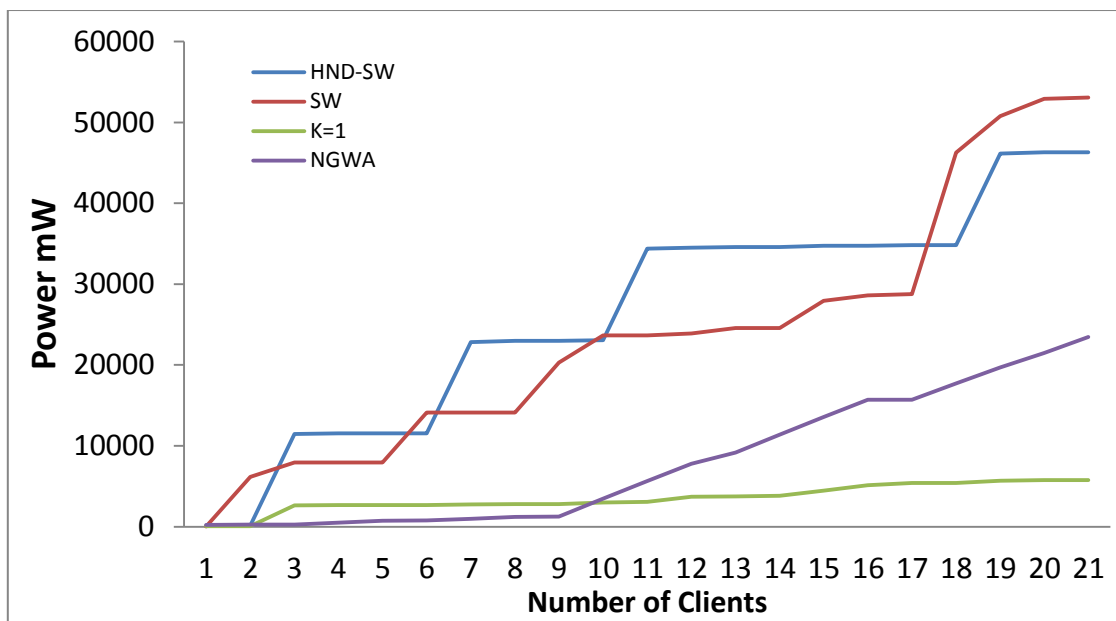

Figure 5- 25: Signal power for various algorithms in random network

In the figures (5.22, 23 and 24) the random tree is used to examine the performance of the all four algorithms. The random network has one root node (source) connected to three children in the level one and the three nodes in the level one connected to nine, seven and five nodes respectively in the level two.

The number of wavelengths used is eight (1300, 1335, 1370, 1405, 1440, 1475, 510 and 1550).

5.6 Summary

The work in this chapter is about dynamic wavelengths allocation in multicast tree optical networks. This research takes in account two parameters, the first of all the dispersion on the received signal. The second parameter is the received signal power.

There are two dynamic wavelength assignment algorithms proposed in this chapter. The shortest wavelength assignment (SWA) algorithm concentrates on selecting the shortest wavelengths because of their zero (1300 nm) or low (greater than 1300 nm) attenuation and high power. The group delay is inversely proportional on the signal power; therefore the group delay is reduced for the short wavelengths because of their high power.

The second algorithm highest number of destinations with shortest wavelengths assignment (HND-SWA) is combined between SWA and another algorithm which select wavelength that is available to the maximum number of destinations. That combination is to reduce the number of wavelengths converters, which are very expensive and energy consuming. Therefore HND-SWA is preferred because of its number of WC reduction and Number of wavelengths reduction as can be seen in the next chapter. This work is published in publication [6] and [8] in the list of publications.

References

- [1] Yueping Cai; Matsuura, M.; Kishi, N.; Miki, T., "Hybrid static-dynamic wavelength/waveband allocation scheme for novel broadcast and select star-ring optical regional network," Communications, 2007. APCC 2007. Asia-Pacific Conference on, vol., no., pp.513-516, 18-20 Oct. 2007.
- [2] J. Zheng; T. Hussein Mouftah, "Optical WDM Networks: Concepts and Design Principles", Institute of Electrical and Electronic Engineering, Canada, vol., no., 2004.
- [3] J. Cai, A. Fumagalli, Ch. Guan, "Centralized vs. Distributed On-Demand Bandwidth Reservation Mechanisms in WDM Ring," Optical Fiber Conference, Anaheim, CA, 2001.
- [4] Chen-Shie Ho; Kuo-Cheng Chiang, "FSA – A Flooding Based Survivable RWA Mechanism for Dynamic Traffic Demands in WDM Optical Networks," Networks, 2009. ICN'09, Eighth International Conference on, vol., no., pp.409-414, 1-6 March 2009
- [5] Ali Norouzi , A.Halim Zaim , and Berk Burak Ustundag, "An integrated survey in Optical Networks: Concepts, Components and Problems", IJCSNS International Journal of Computer Science and Network Security, vol.11 No.1, pp. 10-26, January 2011.
- [6] Acampora, A.S.; Labourdette, J.-F.P., "A traffic-handling comparison of centralized and distributed ATM switching systems," Communications, IEEE Transactions on, vol.43, no.6, pp.2070-2076, Jun 1995
- [7] Adami, D.; Callegari, C.; Giordano, S.; Pagano, M., "Distributed and Centralized Path Computation Algorithms: Implementation in NS2 and Performance Comparison," Communications, 2008. ICC '08. IEEE International Conference on , vol., no., pp.17,21, 19-23 May 2008
- [8] Deborah Morley, Charles Parker, "Understanding Computers: Today and Tomorrow, Comprehensive", Cengage Learning, Boston, USA, vol., no. 14, pp. 238-270, April 2012
- [9] LAN/MAN Standards Committee, "802 IEEE Standard for Local and Metropolitan Area Networks: Overview and Architecture", The Institute of Electrical and Electronics Engineers, New York, NY 10016-5997, USA, vol., no., pp. 1-32, March 2007

- [10] Curt White, "Data Communications and Computer Networks: A Business User's Approach", Cengage Learning, vol., no., pp. 5-11, Jan 2012
- [11] A. J. Rogers, Understanding Optical Fiber Communications, Artech House, vol., no., pp.59-60, Jan 2001
- [12] James C. Daly, "Fiber Optics", CRC Press, Florida, USA, vol., 6th edition, pp. 2-5, Jul 1990
- [13] Casimer DeCusatis, "Fiber Optic Data Communication: Technological Trends and Advances", Academic Press, Elsevier, vol., no., pp. 100-105, 2002
- [14] Industrial Ethernet university, available on, http://www.industrialethernetu.com/courses/301_2.htm, accessed on Feb 2014
- [15] Casimer DeCusatis, "Handbook of Fiber Optic Data Communication: A Practical Guide to Optical Networking", Handbook of Fiber Optic Data Communication Series, Academic Press, Elsevier, 3rd addition, , Oct 2011
- [16] Harry J. R. Dutton, "Understanding Optical Communications", Prentice Hall PTR, vol., no., pp. 63-69, 1998
- [17] Charles (Ed) Taylor, Clive Gifford, Dr. Mike Goldsmith, "The Kingfisher Science Encyclopedia", Pan Macmillan, Kingfisher, U.K., pp. 260-265, 2005
- [18] Zona Land Education, available on <http://zonalandeducation.com/mstm/physics/light/rayOptics/refraction/refraction1.html>, Accessed on Feb 2014
- [19] David M. Rountree, Scientific Paranormal Investigative Research Information and Technology, available online on: <http://www.spinvestigations.org/Light.pdf>, accessed on Feb 2014
- [20] David M. Rountree, Scientific Paranormal Investigative Research Information and Technology, available online on: <http://www.spinvestigations.org/Light.pdf>, accessed on Feb 2014]
- [21] Stefano Bottacchi, "Noise and Signal Interference in Optical Fiber Transmission Systems: An Optimum Design Approach", John Wiley & Sons, 2008, vol. 854, no., pp. 81
- [22] (<http://physicsnet.co.uk/a-level-physics-as-a2/waves/refraction/>)
- [23] Ajoy Ghatak, K. Thyagarajan, "An Introduction to Fiber Optics", Cambridge University Press, 1998, vol. 565, no., pp. 37.

- [24] Duwayne R. Anderson, Larry M. Johnson, Florian G. Bell, "Troubleshooting Optical Fiber Networks: Understanding and Using Optical Time-Domain Reflectometers", Academic Press, Elsevier, vol., 3rd edition, pp. 24-30, Jun 2004
- [25] Siddharth Ramachandran, "Fiber Based Dispersion Compensation", Springer, USA, vol. 5, no., pp. 7-41, Sep 2007
- [26] Rongqing Hui, Maurice O'Sullivan, "Fiber Optic Measurement Techniques", Elsevier Academic Press, vol., no., pp. 394-413, Jan 2009
- [27] Thorlabs Inc, available online: http://www.thorlabs.de/newgrouppage9.cfm?objectgroup_id=5719, accessed on Feb 2014
- [28] Mohammad Azadeh, "Fiber Optics Engineering", Optical Networks, Springer, vol., no., pp. 138-144, Aug 2009
- [29] John Wait; John Kane, "Optical Network Design and Implementation", Cisco System, USA, vol., no., pp. 95-96, March 2004.
- [30] VPI software, user manual, photonic modules, Optical Sources, FunclmpseOut, 2011
- [31] Ting Luo, "Management of Dispersion, Nonlinearity and Polarization-dependent Effects in High-speed Reconfigurable WDM Fiber Optic Communication Systems", ProQuest, University of Southern California, vol., no., pp. 4-7, 2006
- [32] Nicholas Giordano, "College Physics: reasoning and relationships", vol. 2, no., 2nd edition, Cengage Learning, pp. 987-1007, Jan 2012.
- [33] Haitz, R., Kish, F., Tsao, J., and Nelson, J., "Another Semiconductor Revolution: This Time It's Lighting!", Compound Semiconductors, Vol. 6, no. 2, pp. 34-37, March 2000
- [34] Saleh, M.A.; Kamal, A.E., "Approximation Algorithms for Many-to-Many Traffic Grooming in Optical WDM Networks," *Networking, IEEE/ACM Transactions on* , vol.20, no.5, pp.1527,1540, Oct. 2012
- [35] Jianping Wang; Xiangtong Qi; Biao Chen; , "Wavelength assignment for multicast in all-optical WDM networks with splitting constraints," *Networking, IEEE/ACM Transactions on* , vol.14, no.1, pp. 169- 182, Feb. 2006.
- [36] Peng Lin; Shuai Shi; Jian Li; Jie Zhang; Wanyi Gu; , "Novel Virtual Source Based Multicast Routing Algorithm in WDM Networks with Sparse Light

- Splitting," *Communication Technology, 2006. ICCT '06. International Conference on*, vol., no., pp.1-4, 27-30 Nov. 2006.
- [37] Makabe, T.; Takenaka, T., "WDM Multicast Tree Construction Algorithms for Minimizing Blocking Probability under a Delay Constraint," *Computer Communications and Networks, 2008. ICCCN '08. Proceedings of 17th International Conference on*, vol., no., pp.1-6, 3-7 Aug. 2008.
- [38] Chatterjee, B.C.; Sarma, N.; Sahu, P.P., "Priority Based Dispersion-Reduced Wavelength Assignment for Optical Networks," *Lightwave Technology, Journal of*, vol.31, no.2, pp.257-263, Jan. 2013
- [39] Moscholios, I.D.; Logothetis, M.D.; Stylianakis, V.G.; Vardakas, J.S., "The priority wavelength release protocol for dynamic wavelength allocation in WDM-TDMA PONs supporting random and quasi-random bursty traffic," *Network and Optical Communications (NOC), 2013 18th European Conference on and Optical Cabling and Infrastructure (OC&i), 2013 8th Conference on*, vol., no., pp.113-120, 10-12 July 2013
- [40] Gee-Swee Poo; Yinzhu Zhou, "A, new multicast wavelength assignment algorithm in wavelength-routed WDM networks," *Selected Areas in Communications, IEEE Journal on*, vol.24, no.4, pp. 2-12, 2006
- [41] Anping WANG, Qiwu WU, Xianwei ZHOU, Jianping WANG, "A New Multicast Wavelength Assignment Algorithm in Wavelength-Converted Optical Networks", *Int. J. Communications, Network and System Sciences, SciRes Journal on*, vol.2 No.9, pp. 912-916 2009.

Chapter Six

Wavelengths and Their Converters Number

6.1 Introduction

Multicast technology is an efficient method to transmit data from a source to multiple destinations simultaneously [1]. At the present time, with the significant popularity of multicast applications, like video conferencing, voice conversation distribution and HDTV, the multicast scenario is expected to constitute a large portion of the overall network traffic in the near future. One-to-many media transmission has a wide requirement. Optical multicast trees (light-trees) represent one specific case. Wavelength division multiplexing (WDM) technology is established in this case. Using light-tree, wavelength from the source of the multicast session is propagated and split optically until all destinations are reached, the creation of a light-tree may require conversion for the input wavelength, which is assigned (unavailable) to some of the tree links, to avoid blocking in which case, wavelength converters (WCs) are required for the light-tree to be created. WCs are expensive and consume energy; therefore, a wisely designed network must minimize the required number of WCs [2]. Tianping Shuai and Wenbao Ai consider the multicast routing and wavelength assignment problem (MC-RWA) in multi-hop optical WDM networks, where requests arrive one by one. They propose a polynomial time optimal MC-RWA algorithm based on shortest path tree [3]. The problem of MC-RWA in mesh network is investigated in both cases separately and concurrently for sparse splitter and wavelength conversion in WDM networks. In first case, Li Du and Yanning Jia propose routing and wavelength assignment problems separately and in the second case they propose them concurrently [4]. Dynamic wavelength allocation (DWA) in multicast (MC) switching using a centralized scheme is investigated in [5]. The aim for this investigation is to maximize the network capacity and minimize the blocking probability in the wavelength division multiplexer network (WDM). In [6] Rongping Lin, Wen-De Zhong, Sanjay Kumar Bose and Moshe Zukerman investigate multicast traffic grooming with a leaking strategy in a mesh network topology. In the leakage, they mean that a light-tree may send the data of a multicast connection to node/s that are not in the multicast destinations. These leaking strategies improve the sharing of light-trees, which lead to lower blocking ratios. They have proposed two

multicast traffic grooming algorithms with leaking strategy. First one called multicast traffic leaky grooming (MTLG) and the second is called multicast traffic hybrid grooming (MTHG) are proposed. Wavelength conversion is expensive and energy consume therefore, Fen Zhou, Miklós Molnár, Bernard Cousin, and Chunming Qiao propose algorithm without WCs. Due to the light splitting constraint and the absence of wavelength converters, several light-trees may be required to establish a multicast session [7]. Mesh network has been studied [8]-[10] to investigate quality of service, minimize delay, cost and blocking probability respectively.

6.1.1 Wavelength

Wave is an energy disturbance that propagates from one point to another in a medium without giving the medium any permanent displacement. All waves (electromagnetic, mechanical, optical...etc.) have a frequency and wavelength. It is defined as the physical distance between two points having the same phase in two consecutive cycles of a periodic wave along a line in the direction of propagation. [11]

Some of waves have different periodic times and waveforms and in addition, are continuously changing with time and therefore they do not have a specific wavelength but a bandwidth. Each colour has its specific wavelength such as blue colour has wavelength of 450 nanometres, green colour has wavelength of 530 nanometres and red colour has wavelength of 670 nanometres. [12].

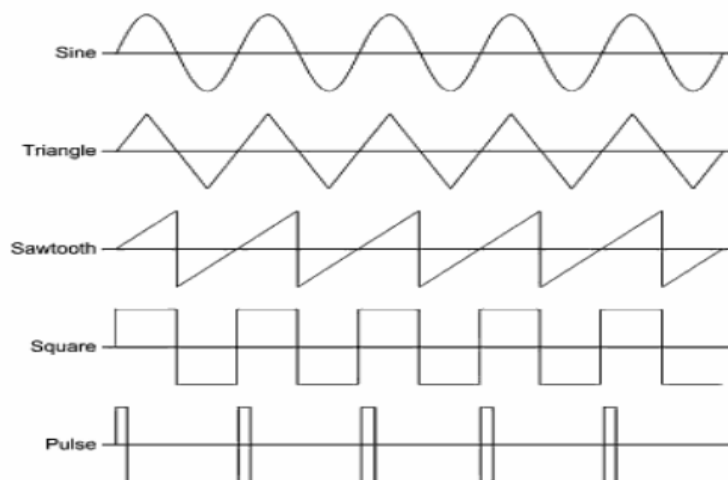

Figure 6- 1: Different types of waves [13]

There are different wavelengths used for data transmission. Some of the communication works have used millimetres wavelengths which start from 1 mm and above (30-300 GHz) [14]. However the disadvantage for using mm-waves is that the maximum data rate is limited, so separation between transmit and receive is necessary to overcome interference, and less than half of the band is available for transmission. It also has a limited distance for up to 0.5 km because of the sensitivity to atmospheric effects. [15]. Eye visible range is a part of the nanometre wavelengths which lie on the range of 400-700 nm and some sensitivity up to 800 nm while other animals like one jumping spider can visible below 315 nm and other animals like beetles, butterflies and snakes have visibility up to 60 nm into red which lie in the infrared range. [16]. Nanometre wavelengths are used in a wide range of technologies. The range of 1400-2000 nm wavelengths have been used in the image sensing and the range of light used is called the eye-safe region because more light is absorbed at the cornea than light in the visible region and therefore less damage will occur to the retina [17]. They have been used in the astronomy telescopes [18], using 750 nm and above which is called infrared and is used in detecting clouds, oceans and seas eddies and other Earth investigation features. Ultraviolet 1 up to 400 nm is used for space-borne remote sensing of molecular species in Earth's troposphere and stratosphere. [19].

There are many advantages of using nanometre wavelengths in optical fibres since hundreds of wavelengths [20] can be transmitted using WDM especially dense wavelength division multiplexing (DWDM) with very low spacing which reach 0.4 nanometre, simplify design, low cost, wide band and high data rate. [21]

6.1.2 Wavelengths Capacity

The data rate per wavelength has been improved by a significant amount. It was only 1.6 Gb/s, at which 13km non-repeater transmission is confirmed at 1.3 pm, where fibre dispersion almost disappears and also 100 Mbit/s at 30 km, 800 Mbit/s at 20 km, 1.2 Gb/s at 23 km. [22]. A 10-wavelength, polarization-multiplexed is demonstrated to operate at 112 Gbps per wavelength [23]. The proposal obtained the record of data rate per wavelength (214 Gbps) and record distance of 720-km standard single-mode fibre [24]. The proposed gigabit access passive optical network using wavelength division multiplexing project aims to implement 64-Gb/s

data transmission over 20-km single-mode fibre. Per-user symmetric data rates of 1-Gb/s will be achieved using wavelength division multiplexing passive optical network (WDM-PON) architecture with a 1:64 user split per PON segment [25].

Other work has successfully demonstrated the improvement by the implementation of chromatic dispersion compensation for cost effective spectrum-sliced 16-channel DWDM PON system with data rate 2.5 Gb/s per wavelength and flat spectrum in wavelength range from 1545.32 nm to 1558.98 nm. [26] However, the net spectral efficiencies of the channels vary from (2 b/s/Hz) for the (112-Gb/s) channel to (3.33 b/s/Hz) for the (1.15-Tb/s) super-channels [27].

The far distance transmission of 8 wavelengths 216.8 Gbps Nyquist wavelength-division-multiplexing (N-WDM) signals over 1750-km G.652 fibre consisting of 950-km real and 800-km lab fibres with erbium-doped fibre amplifier (EDFA)-only amplification has recorded a spectral efficiency (SE) of 4 b/s/Hz [28]. The work in Nippon Telegraph and Telephone Corporation (NTT) has successfully demonstrated ultra-high-capacity (69.1 Tb/s) optical transmission to meet the expected rapid increase in data traffic. This capacity is the highest reported in the optical communication field. A 69.1-Tbit/s signal generated by wavelength division multiplexing (WDM) of 432 wavelengths each with a capacity of 171 Gb/s was transmitted over a single fibre over 240 km [29]. After these facts about the data rate per wavelength and their effect on the spectrum efficiency, increasing of the number of wavelengths will significantly affect very well the data rate and spectrum efficiency and that is what will be investigated in this work.

6.1.3 Conversion Cost

In the multicast network the wavelengths conversion is necessary to transmit data to various destinations using different wavelengths. Assume that the WDM optical network has a number of nodes (N), a number of links (L) and number of wavelengths (W). The multicast tree network can be represented by a graph of ($G = (n, l, w)$). Where n, l, w represent nodes, links and available wavelengths in the tree network. A link (l_i) is connects node (n_i) and node (n_{i+1}) where ($l_i \in L$ and $n_i, n_{i+1} \in N$). Data is sent using link (l_i) by wavelength (w_i) where ($w_i \in W$).

According to the definitions above, the conversion cost indicator can be represented by the cost of $c_i = (\lambda_i, \lambda_{i+1})$ which is the cost of converting wavelength (λ_{i+1}) to wavelength (λ_i) on the coming link $l_i = (n_i, n_{i+1})$ and the outgoing link $(l_{i+1} = (n_{i+1}, n_{i+2}))$. The indicator (c_i) is zero when the $(\lambda_i = \lambda_{i+1})$.

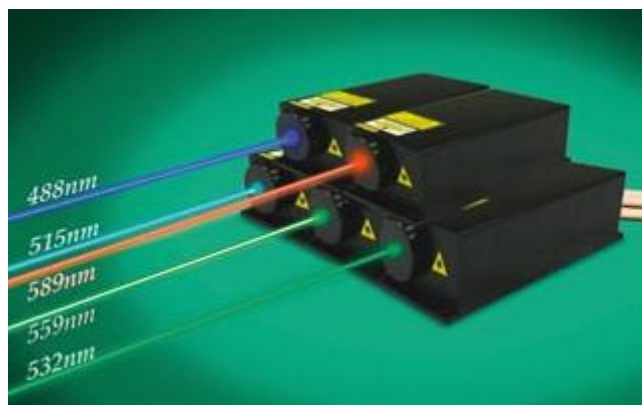

Figure 6- 2: Wavelengths converter [30]

The wavelength conversion cost depends on several parameters which affect the conversion cost by a negative or positive side.

1. Wavelengths conversion degree which is defined as the number of wavelengths which the input wavelength can be converted to and it is denoted by (d) . The tuneable laser can convert wavelengths to an interval of wavelengths. Therefore the laser transmits at (λ_1) can be tuned to (λ_3) , then this laser should be able to be tuned to (λ_2) , since (λ_2) is closer to (λ_3) than (λ_1) [31]. This has been described in chapter three in detail and it explained the different wavelengths conversion degrees with different converters.
2. Wavelength conversion range is the maximum difference between a wavelength and a wavelength that can be converted from it [32]. It has been explained by details in chapter three.
3. Number of wavelength converters (WC) affects the wavelength conversion cost. WC is expensive device and bears some side effects that degrade the signal quality. Minimizing the number of WC significantly reduces the conversion cost.
4. Availability of wavelengths conversion is very expensive if the availability is in all network nodes. Thus it is economically efficient to choose which nodes

have to have wavelength conversion and if it is not included in all nodes then this is called sparse wavelength conversion network [33].

5. The technique type is effecting the conversion time, quality of signal, power consumption and implementation complexity. There many types of conversion that are explained in chapter three. Using Optical-Electronic-Optical (O-E-O) or all-optical wavelengths conversion also affects the performance of the WC. [34].

6.2 Wavelengths assignment algorithms

The proposed algorithms are the SWA and HND-SWA algorithms, which are explained, in the last chapter but their investigation which is presented in this chapter is about the number of wavelengths and number of wavelengths converters. HND-SWA algorithm concentrates on reducing the number of used wavelengths in the multicast request and hence reducing the number of WC to transmit data to their destinations.

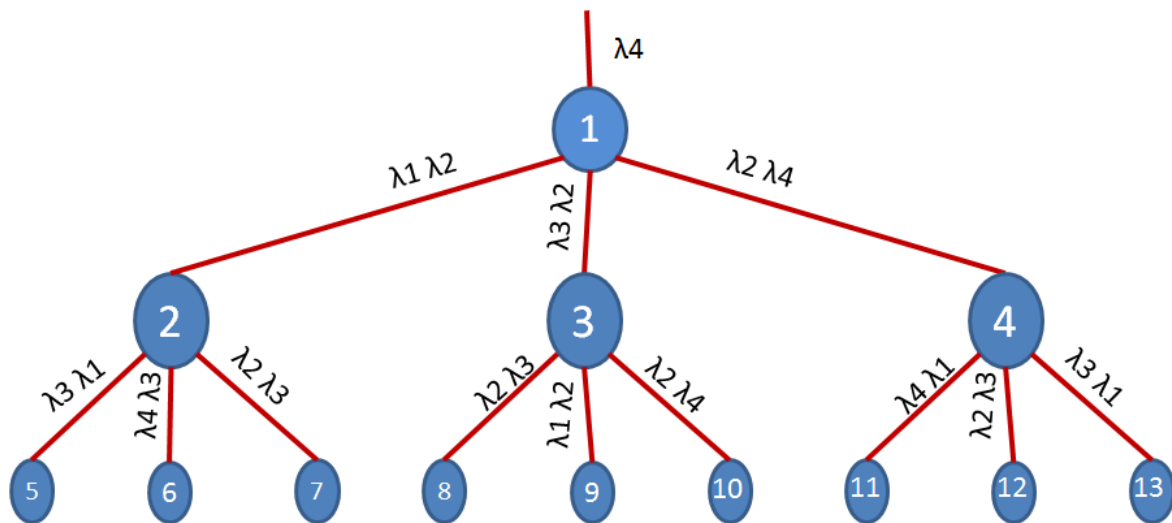

Figure 6- 3: Ternary tree with different available wavelengths

The ternary tree network in figure 6.3 displays the available wavelengths in each link and the number of nodes including the destinations which are the leaf nodes. Assume the multicast tree is performed in graph $(G = (n, l, w))$ where (n, l, w) is the number of nodes, links and wavelengths respectively. If each wavelength can reach number of destinations $\{\lambda_i = (d_1, d_2, d_3, \dots d_i)\}$, then the chosen wavelength will be the wavelengths which has maximum number of destinations. According to the graph

in figure the ternary tree has two levels and each link has two available wavelengths. To choose wavelength/s to carry data from source to destinations, a specific algorithm has to be followed. The SWA algorithm follows the steps below to select the shortest wavelength/s:

Algorithm: *shortest wavelength allocation*

Constant: *width (number of wavelengths), length (number of destinations)*

Input: *multicast tree, input_wavelength*

Output: *assigning wavelength*

Begin

Selected wavelengths = 0

Wavelength converters number = 0

For n=1 to number_of_wavelengths do

Find shortest wavelength;

Assign the shortest wavelength;

Selected wavelengths = Selected wavelengths + 1

if selected wavelength not equal input wavelength

Wavelength converters number = Wavelength converters number + 1

End if

Remove the assigned wavelengths destinations;

Repeat for all remaining destinations;

End for

End

By using SWA algorithm the selected wavelengths in the tree network will be as shown in figure 6.4.

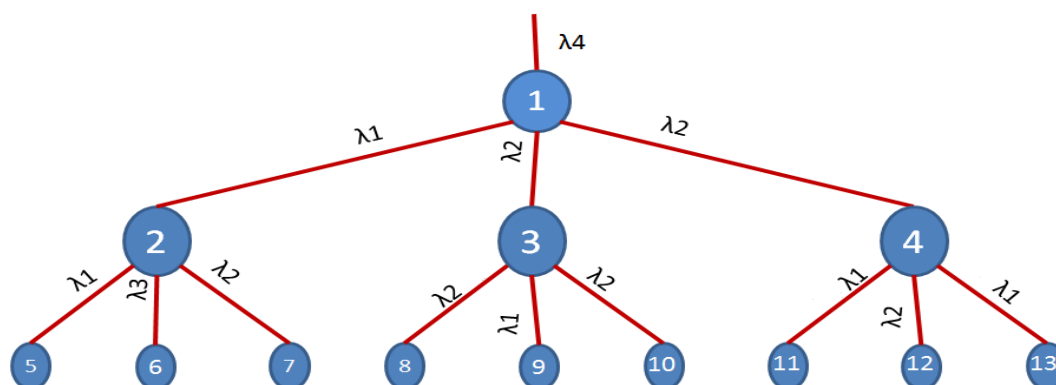

Figure 6- 4: Ternary tree with SWA algorithm

Highest number of destinations with shortest wavelength assignment algorithm (HND-SWA) is the proposed and preferred algorithm in multicast technology and is used in this chapter. There are three required calls to destinations (2, 3, 4), the HND-SWA algorithm accounts for the number of destinations that each wavelength can reach ($\lambda_2 = (d_2, d_3, d_4), \lambda_3 = (d_2, d_3,) , \lambda_4 = (d_4)$), HND-SWA choose only (λ_2)

because it has the maximum number of destinations and it reaches all destinations and there is no need to select any other wavelength. The HND-SWA algorithm for the ternary tree network selects wavelengths as shown in figure 6.5 and it can be described as below:

Algorithm: highest number of destinations with shortest wavelength allocation

Constant: width (number of wavelengths), length (number of destinations)

Input: multi cast tree, input_wavelength

Output: assigning wavelength, number of selected wavelengths, wavelengths converters number

Begin

Selected wavelengths = 0

Wavelength converters number = 0

For n=1 to number_of_wavelengths do

 Calculate number of destinations for each wavelength

 Find wavelength with maximum destinations

 If there are two or more wavelengths with the same number of destinations

 Choose shortest one

 else

 Assign it

 End if

 Selected wavelengths = selected wavelengths + 1

 If selected wavelength not equal input wavelength

 Wavelength converters number = wavelength converters number + 1

 End if

 Remove the assigned wavelengths destinations;

 Repeat for all remaining destinations

End for

End

The SWA algorithm allocates the shortest wavelength which is (λ_1) to destination 2 and assigns (λ_2) to destinations 3 and 4. Thus it uses one WC to convert input wavelength (λ_4) to first output wavelength (λ_1) and utilize another WC to convert input wavelength (λ_4) to wavelength (λ_2). That means it utilized two WC to multicast the call to the three children.

Unlike the SWA algorithm, the HND-SWA algorithm chooses wavelengths which are available to the highest number of destinations as shown in figure (6.5). The HND-SWA has assigned one wavelength (λ_2) to destinations (2, 3 and 4). Therefore, it has utilized also just one WC to convert (λ_4) to (λ_2). The other nodes have used also just one wavelength to multicast to their children except node (4) which has selected two wavelengths (λ_1, λ_2). All the parent nodes have used just one WC for the multicast.

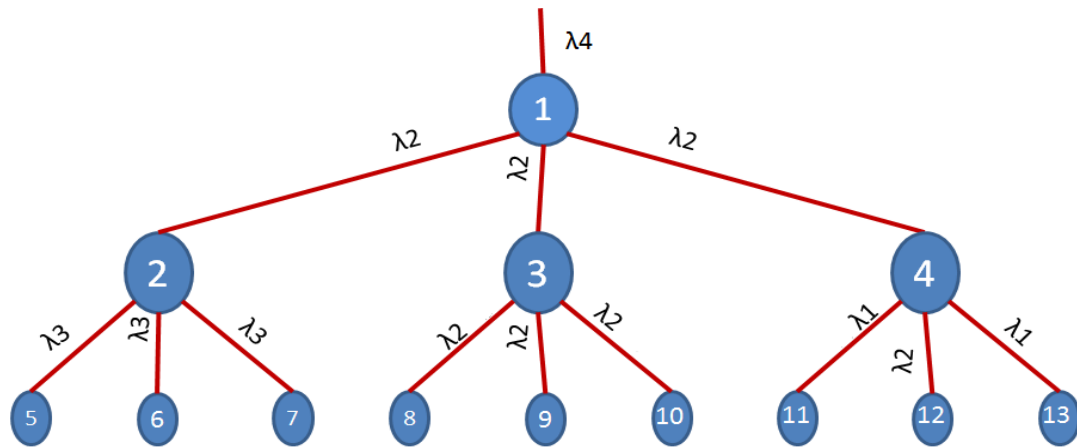

Figure 6- 5: Ternary tree with HND-SWA algorithm

6.3 Results and Discussion

The number of utilized wavelengths and wavelengths converters are computed by implementing various symmetric and random tree networks using LabVIEW software. Generally, the tree networks have three levels and they consist of source (server), leaf nodes (destinations) and wavelengths switches between them to multicast calls. The wavelengths through the network are produced randomly with out-degree of two. Out-degree is the number of wavelengths available in each link. The number of destinations is varied from one network to another. That depends on the arity of the network (number of children for each parent node).

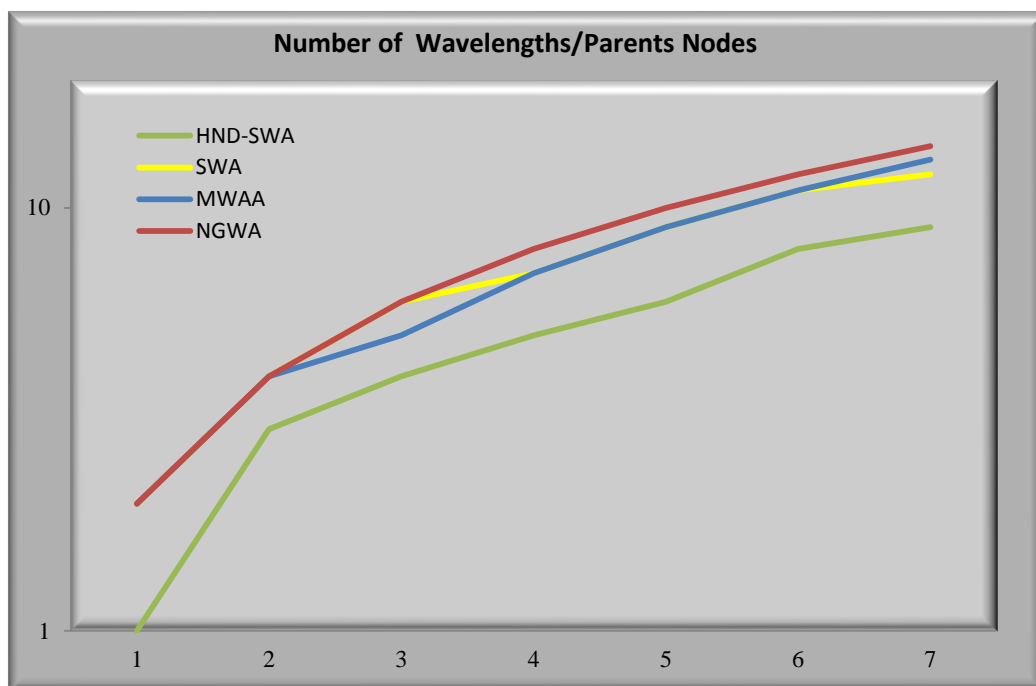

Figure 6-6: Number of utilized wavelengths in a binary tree network

To compute the number of wavelengths converters, a multicast switch has to be taken in account. The S-C-S-C multicast switch is used for all compared algorithms in this work to obtain the results. Although the MWAA and NGWA have used different multicast switches, in contrast this work has used the same switch to make the comparison fair. For each assigned wavelength with input wavelength not the same one is added to the counter.

While the number of children is just two in the binary tree network, the number of used wavelengths for each parent node is either one or two at the multicast. The number of wavelengths has recorded the lowest number at HND-SWA algorithm figure 6.6, while the highest number of wavelengths is recorded at NGWA algorithm. Although the NGWA and MWAA algorithms has concentrated on reducing the number of wavelengths converters, the HND-SWA algorithm has registered either better or same results as the other algorithms in the binary tree network figure 6.7.

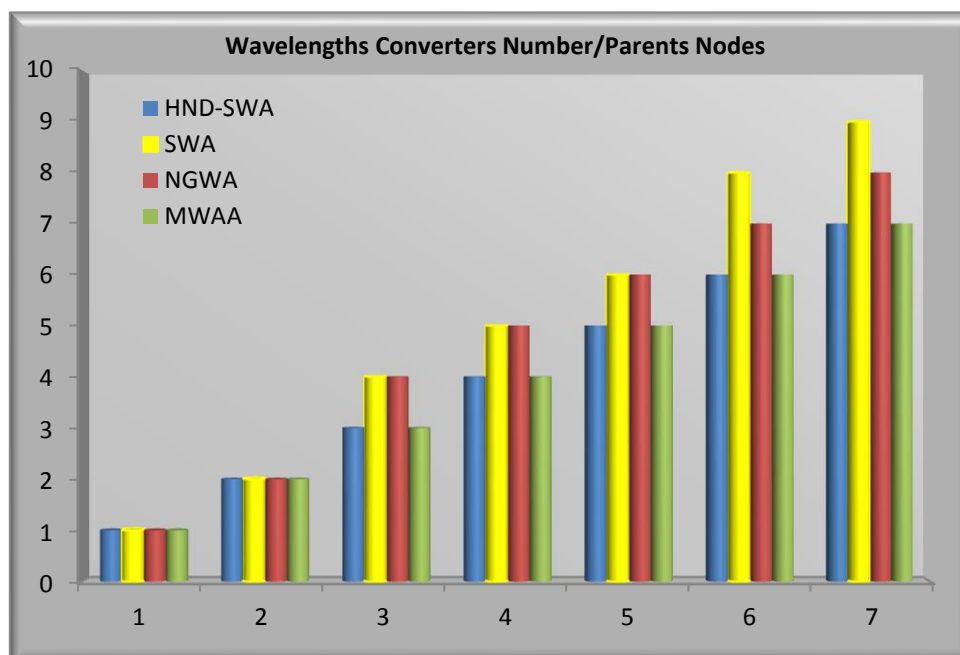

Figure 6-7: Number of utilized wavelength converters in a binary tree network

The number of used wavelengths still has the smallest number in the HND-SWA algorithm at ternary tree network. In the beginning of the curve shown in figure 6.8, the SWA and HND-SWA algorithms has the same performance. That happens when the available wavelengths are the shortest wavelength and are available to all three children. The other situation can be also when the shortest wavelength is available to two children and all other wavelengths have the maximum out-degree of two. The

lowest number of wavelengths converters has been registered in the HND-SWA algorithm figure 6.9, and the SWA algorithm has the second best performance, which happens when the available wavelengths are the shortest wavelengths.

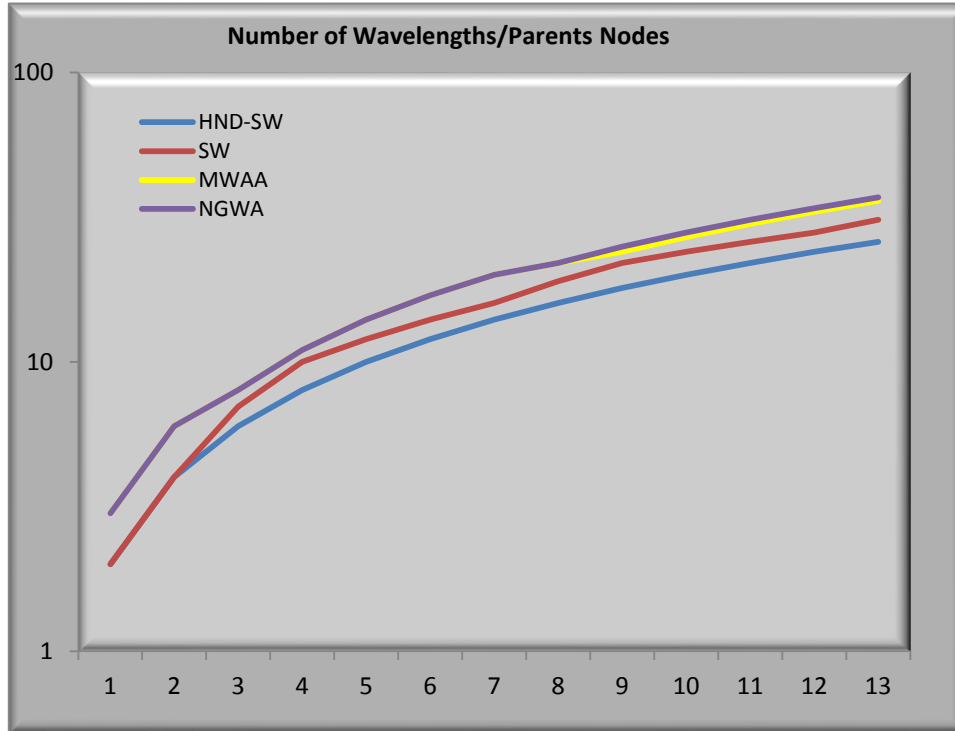

Figure 6-8: Number of utilized wavelengths in a ternary tree network

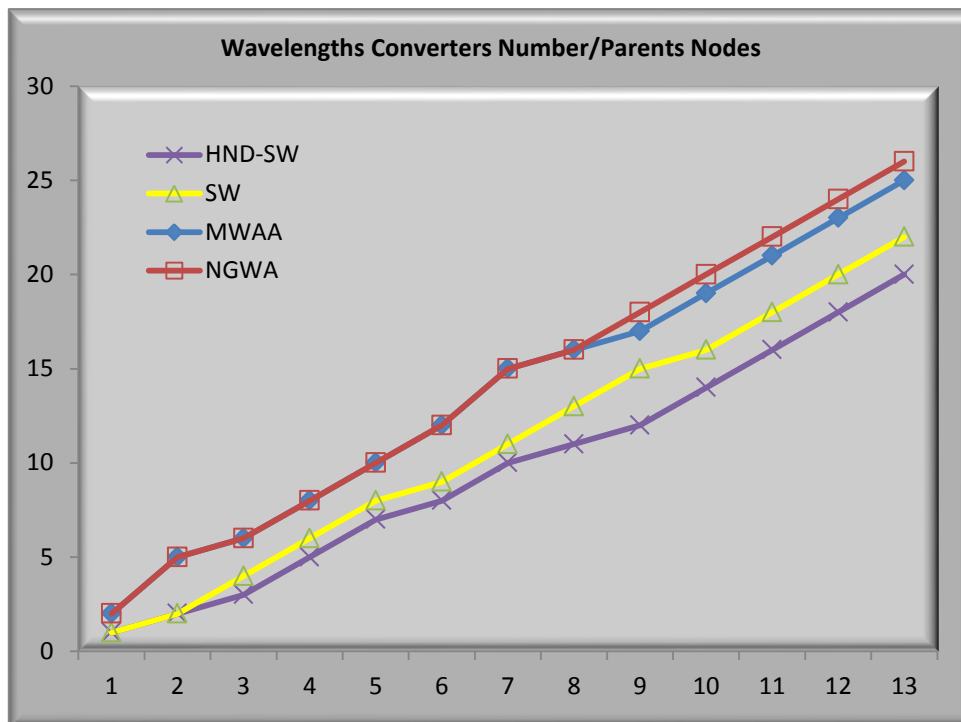

Figure 6-9: Number of utilized wavelength converters in a ternary tree network

The ternary and quaternary trees are implemented in three levels with out-degree of two (two wavelengths available in each link), and the number of destinations is 27 and 64 respectively, while the number of parents is 13 and 21 respectively. In the quaternary tree, the number of used wavelengths to multicast calls has the lowest value for the HND-SWA algorithm figure 6.10. Wavelength converters have recorded the minimum number in the quaternary tree for the HND-SWA algorithm figure 6.11.

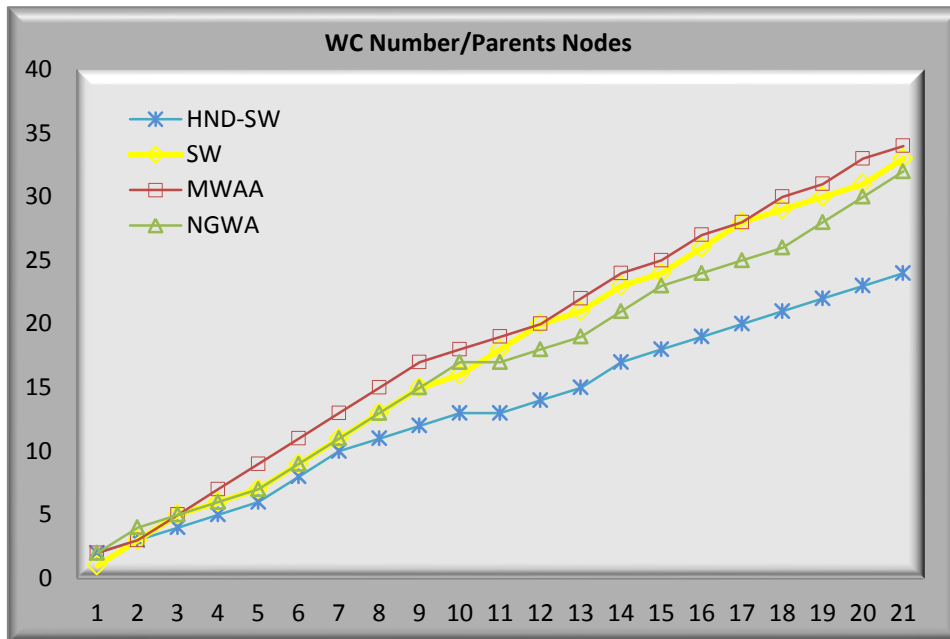

Figure 6-10: Number of utilized wavelengths in a quaternary tree network

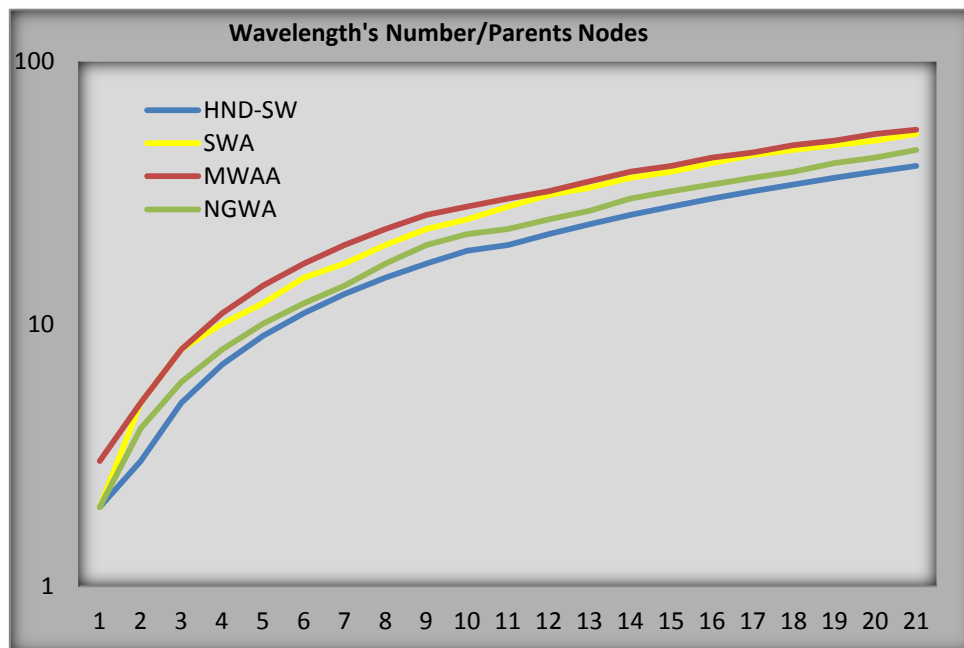

Figure 6-11: Number of utilized wavelength converters in a quaternary tree network

To obtain results for different trees and various situations, the random tree is implemented and examined. The random tree has three levels and 65 leaf nodes. Each level has diverse number of nodes and the children number of each node is different. This has been varied from one to nine children to test the number of wavelengths and their converters in various cases. The number of wavelengths available in the whole network is eight and there are just three wavelengths available in each link. Figures 6.12 and 6.13 show that the HND-SWA algorithm has the best performance compared with the other algorithms.

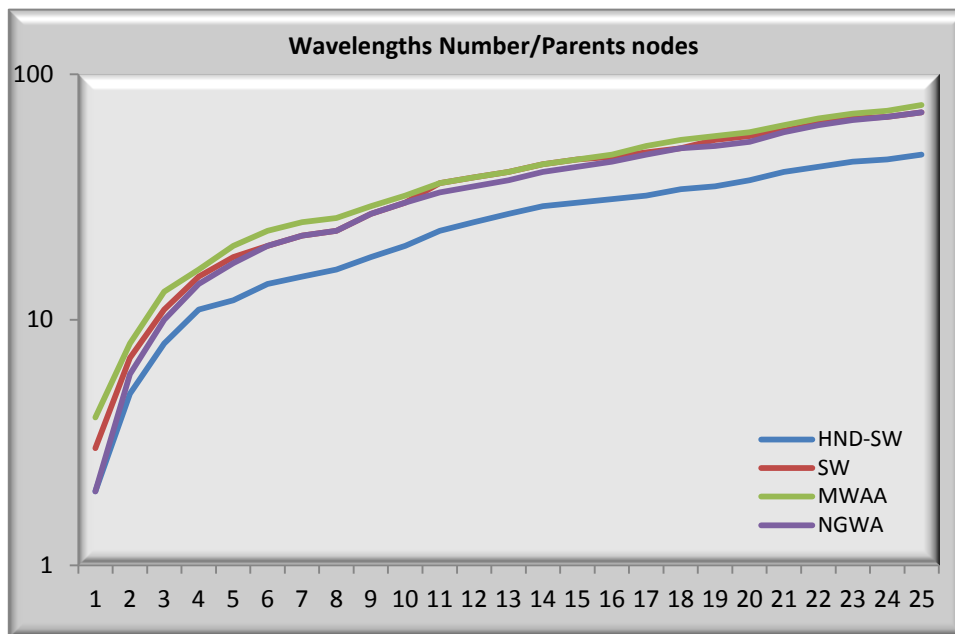

Figure 6-12: Number of utilized wavelengths in a random tree network

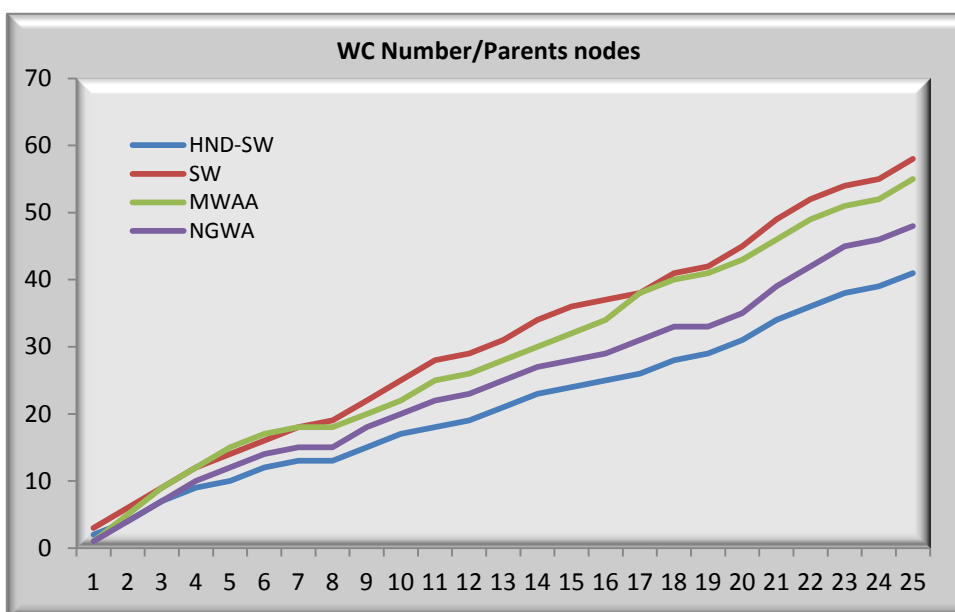

Figure 6-13: Number of utilized wavelength converters in a random tree network

6.4 Summary

There are two wavelengths assignment algorithms proposed in this chapter to reduce the number of wavelengths and wavelengths converters. The wavelengths' number has been decreased by a significant value by using HND-SWA algorithm, which follows two steps to ensure reaching the highest number of clients with the least number of wavelengths. Wavelength converters are very expensive devices and reducing them leads to minimize the network cost. The proposed algorithm (HND-SWA) has decreased the number of wavelengths converters (WC) to serve calls to multi-clients.

References

- [1] Xiaojun Yu; Gaoxi Xiao; Tee Hiang Cheng, "Performance comparisons between lightpath and light-tree schemes in dynamic multicast traffic grooming process," *Photonics Global Conference (PGC), 2012*, vol., no., pp.1,5, 13-16 Dec. 2012.
- [2] Huang, W.; Tang, L.; Razo, M.; Sivasankaran, A.; Tacca, M.; Fumagalli, A., "A recursive algorithm to reduce the number of wavelength converters in support of multiple light-trees," *Transparent Optical Networks (ICTON), 2011 13th International Conference on*, vol., no., pp.1, 1, 26-30 June 2011.
- [3] Tianping Shuai; Wenbao Ai, "Approximation Algorithms for Multicast Routing and Wavelength Assignment in Multi-hop Optical WDM Networks," *Computational Sciences and Optimization (CSO), 2011 Fourth International Joint Conference on*, vol., no., pp.1291, 1295, 15-19 April 2011.
- [4] Li Du; Yanning Jia, "A dynamic multicast RWA algorithm for WDM network with sparse splitting and wavelength conversion capability," *Electronics, Communications and Control (ICECC), 2011 International Conference on*, vol., no., pp.613, 616, 9-11 Sept. 2011.
- [5] Abbas, R.S.; Al-Raweshidy, H., "New multicast switch-based multicast wavelength allocation algorithm to increase network capacity," *Future Communication Networks (ICFCN), 2012 International Conference on*, vol., no., pp.164, 169, 2-5 April 2012.

- [6] Rongping Lin; Wen-De Zhong; Bose, S.K.; Zukerman, M., "Leaking Strategy for Multicast Traffic Grooming in WDM Mesh Networks," *Lightwave Technology, Journal of*, vol.30, no.23, pp.3709, 3719, Dec.1, 2012.
- [7] Fen Zhou; Molnar, M.; Cousin, B.; Chunming Qiao, "Cost Bounds and Approximation Ratios of Multicast Light-Trees in WDM Networks," *Optical Communications and Networking, IEEE/OSA Journal of*, vol.3, no.4, pp.323, 334, April 2011.
- [8] Barat, S.; Kumar, A.; Pradhan, A.K.; De, T., "A light-forest approach for QoS multicasting in WDM networks," *Industrial and Information Systems (ICIIS), 2012 7th IEEE International Conference on*, vol., no., pp.1-6, 6-9 Aug. 2012.
- [9] Danh Le, Dinh; Molnar, Miklos; Palaysi, Jerome, "An improved multicast routing algorithm in sparse splitting WDM networks," *Computing, Management and Telecommunications (ComManTel), 2013 International Conference on*, vol., no., pp.99-104, 21-24 Jan. 2013.
- [10] Constantinou, C.K.; Ellinas, G., "A novel technique for survivable multicast routing in optical WDM mesh networks," *Optical Communication (ECOC), 2011 37th European Conference and Exhibition on*, vol., no., pp.1, 3, 18-22 Sept. 2011.
- [11] Matthew M. Radmanesh, "RF & Microwave Design Essentials: Engineering Design and Analysis from DC to Microwaves", AuthorHouse, vol., no., pp. 295-307, 2007
- [12] James Nairne, "Psychology", Cengage Learning, vol., 6th ed., pp. 141, Jan. 2013
- [13] Ethan Winer, "The Audio Expert: Everything You Need to Know about Audio", Taylor & Francis, vol., no., pp. 28, 2012
- [14] Jamal Deen, "Silicon-Based Millimetre-wave Technology", Advances in imaging and electron physics, Academic Press, vol. 174, no., pp.1-9, Nov. 2012
- [15] Jonathan Wells, "Multigigabit Microwave and Millimeter-Wave Wireless Communications", Artech House mobile communications series, Artech House, vol., no., pp. 118, 171, 2010
- [16] Michael F. Land, Dan-Eric Nilsson, "Animal Eyes Oxford Animal Biology Series", Oxford University Press, vol., Edition 2, Mar. 2012

- [17] Jun Ohta, "Smart CMOS Image Sensors and Applications", Optical Science and Engineering, CRC Press, vol., no., pp. 83, Dec. 2010
- [18] Nigel Henbest; Michael Marten, "The New Astronomy", Cambridge University Press, vol., no., pp. 9, Aug. 1996], Wavelength-Division Multiplexing in telecommunication applications [Liang Tang; Stanford University, "Nanometre-scale Germanium Photodetector Enhanced by Optical Antennas", ProQuest, vol., no., pp. 89, 2008
- [19] Robert Henson; Committee on Earth Science and Applications from Space: A Community Assessment and Strategy for the Future; Space Studies Board, Division on Engineering and Physical Sciences; National Research Council, "Satellite Observations to Benefit Science and Society: Recommended Missions for the Next Decade", National Academies Press, vol., no., pp. 32, Sep. 2008
- [20] Billah, A.R.B.; Bin Wang; Awwal, A. A S, "Effective traffic grooming in WDM rings," *Global Telecommunications Conference, 2002. GLOBECOM '02. IEEE* , vol.3, no., pp.2726,2730 vol.3, 17-21 Nov. 2002
- [21] Casimer DeCusatis; Casimer DeCusatis, "Fiber Optic Data Communication: Technological Trends and Advances", Academic Press, vol., no., pp.141, 2002
- [22] Kimura, Tatsuya, "Single-mode systems and components for longer wavelengths (Invited Paper)," *Circuits and Systems, IEEE Transactions on*, vol.26, no.12, pp.987-1010, Dec 1979
- [23] Evans, P.; Fisher, M.; Malendevich, R.; James, A.; Studenkov, P.; Goldfarb, G.; Vallaitis, T.; Kato, M.; Samra, P.; Corzine, S.; Strzelecka, E.; Salvatore, R.; Sedgwick, F.; Kuntz, M.; Lal, V.; Lambert, D.; Dentai, A.; Pavinski, D.; Zhang, J.; Behnia, B.; Bostak, J.; Dominic, V.; Nilsson, A.; Taylor, B.; Rahn, J.; Sanders, S.; Sun, H.; Wu, K. -T; Pleumeekers, J.; Muthiah, R.; Missey, M.; Schneider, R.; Stewart, J.; Reffle, M.; Butrie, T.; Nagarajan, R.; Joyner, C.; Ziari, M.; Kish, F.; Welch, D., "Multi-channel coherent PM-QPSK InP transmitter photonic integrated circuit (PIC) operating at 112 Gb/s per wavelength," *Optical Fiber Communication Conference and Exposition (OFC/NFOEC), 2011 and the National Fiber Optic Engineers Conference* , vol., no., pp.1,3, 6-10 March 2011
- [24] Wei-Ren Peng; Morita, I.; Takahashi, H.; Tsuritani, T., "Transmission of High-Speed (> 100 Gb/s) Direct-Detection Optical OFDM Superchannel," *Lightwave Technology, Journal of*, vol.30, no.12, pp.2025-2034, 15 June 2012.

- [25] Prince, K.; Gibbon, T.B.; Rodes, R.; Hviid, E.; Mikkelsen, C.I.; Neumeyr, C.; Ortsiefer, M.; Ronneberg, E.; Roskopf, J.; Ohlen, P.; De Betou, E.I.; Stoltz, B.; Goobar, E.; Olsson, J.; Fletcher, R.; Abbott, C.; Rask, M.; Plappert, N.; Vollrath, G.; Monroy, I.T., "GigaWaM—Next-Generation WDM-PON Enabling Gigabit Per-User Data Bandwidth," *Lightwave Technology, Journal of*, vol.30, no.10, pp.1444,1454, May15, 2012.
- [26] Spolitis, S.; Bobrovs, V.; Ivanovs, G., "New generation energy efficient WDM-PON system using spectrum slicing technology," *Ultra-Modern Telecommunications and Control Systems and Workshops (ICUMT), 2012 4th International Congress on*, vol., no., pp.558,562, 3-5 Oct. 2012.
- [27] Yue-Kai Huang; Ip, E.; Xia, T.J.; Wellbrock, G.A.; Ming-Fang Huang; Aono, Y.; Tajima, T.; Cvijetic, M., "Mixed Line-Rate Transmission (112-Gb/s, 450-Gb/s, and 1.15-Tb/s) Over 3560 km of Field-Installed Fiber With Filterless Coherent Receiver," *Lightwave Technology, Journal of*, vol.30, no.4, pp.609,617, Feb.15, 2012.
- [28] Jianjun Yu; Ze Dong; Hung-Chang Chien; Zhensheng Jia; Xinying Li; Di Huo; Gunkel, M.; Wagner, P.; Mayer, H.; Schippel, A., "Transmission of 200 G PDM-CSRZ-QPSK and PDM-16 QAM With a SE of 4 b/s/Hz," *Lightwave Technology, Journal of*, vol.31, no.4, pp.515,522, Feb.15, 2013.
- [29] <http://www.ntt.co.jp/RD/OFIS/active/2010pdf/hot/nw/06.html>
- [30] <http://www.directindustry.com/prod/ntt-electronics/wavelength-conversion-dpss-lasers-35545-221748.html>
- [31] Sanguthevar Rajasekaran; John Reif, "Handbook of Parallel Computing: Models, Algorithms and Applications", CRC Press, vol., no., pp. 23-3, 2007
- [32] T. Venkatesh; C. Siva Ram Murthy, "An Analytical Approach to Optical Burst Switched Networks", Springer, vol., no., pp. 137, Mar. 2010
- [33] Yousuf Khambaty, "Efficient Wavelength Conversion Using Four Wave Mixing in Semiconductor Optical Amplifier for Intensity Modulated Differential Phase Shift Keying Signal", The University of Texas at San Antonio. Electrical & Computer Engineering, ProQuest, vol., no., pp. 34-35, 2008
- [34] Thomas E. Stern; Georgios Ellinas; Krishna Bala, "Multiwavelength Optical Networks: Architectures, Design, and Control", Cambridge University Press, vol., no., pp. 275-276, 2009

Chapter Seven

Centralised Wavelengths Assignment Technology

7.1 Introduction

Wavelength assignment is a topic which is widely researched in optical networks, especially in wavelength division multiplexing networks (WDM). The centralized algorithm has been proposed in this chapter and there are two scenarios for the centralised algorithm. The main effect and improvement in the algorithm is to save network capacity by minimizing the decrease in network capacity after each wavelength assignment. The term decrease network capacity and decrease in network capacity are well investigated and analysed. There are also mathematical equations that have been formed and created for them. By our knowledge, this is the first time the equations have been created. The performance of our tested networks is mainly applies to on the perfect complete binary, ternary and quaternary networks. The idea is rarely investigated in perfect complete tree networks, while the other works usually study random tree networks. The work in this chapter is concentrated on a centralized algorithm wherever we have mentioned to a distributed technology in the previous chapters. Capacity decrease for different networks is compared between our algorithm and other different algorithms. However, we did not use any active devices in our scenarios. Therefore, the results are suitable for passive optical networks.

The optical network technology is the key for the current and future revolution in the communications. In the past few years, the wavelength-division multiplexing (WDM) networks have been the strongest available candidate for the future high requirements to provide enormous network capacity. Dense wavelength-division-multiplexing (DWDM) can provide a hundreds of channels (wavelengths) for each individual optical fibre. Bell Labs broke optical transmission record 100 petabit per second kilometre barrier [1] using 155 lasers (wavelengths), each one carrying 100 Gigabits of data per second to 7000 kilometre distance. The number of wavelengths can be increased rapidly in the next several years. In any optical fibre, wavelengths are transmitted without any interference by using different wavelengths. There are dual and simplex fibre cables. The dual core system allows data to be transferred in

bi-directional, as opposed to simplex fibre cables, which typically only propagate data in one direction. The bidirectional communication is achieved over single-mode simplex fibre using multiple wavelengths when the Wavelength Division Multiplexing (WDM) systems are utilized. Wavelength collision is caused if optical signals from two inputs are forwarded to the same output using the same wavelength. Nevertheless in [2] the backbone network capacities greater than 1 Tb/s over a single fibre have been achieved by means of wavelength division-multiplexing (WDM) technology with hundreds of channels. That means the optical fibre using WDM can be the best solution for the high demand for the high data rate and the high values of bandwidth.

The centralized assignment is represented by the dynamic wavelength assignment (DWA) algorithms. In [3]-[6] the centralized scheme has been implemented. In [3], they investigated the problem of wavelength assignment in wavelength reusable multi-carrier distributed (WRMD) wavelength-division-multiplexing (WDM) ring networks. In conventional WDM ring networks, each edge node (EN) has its own light sources, and optical channels, called light-paths, which are established by using optical carriers generated from laser diodes (LDs) at the source EN. In this network, light-paths between source and destination ENs are established by using carriers generated from a centralized multi-carrier light source. In [4] work, a centralized network controller is used, and found that estimating the impact of the physical impairments on the quality of a light-path before provisioning can cause a significant delay.

Quality of service aware wavelength assignment algorithms are proposed that consider both bit-error rate (BER) and latency constraints. The experimental result [5] of Dynamic Impairment Constraint Optical Networking (DICONET) proposal for centralized and distributed control plane integration schemes have been proposed with all-optical mesh networks. In [6], the design and evaluation of their optical broadcast-and-select wavelength-routed network architecture is presented that uses a centralized multicarrier light source (C-MCLS). The large numbers of optical carriers/wavelengths generated by the C-MCLS are distributed to all edge nodes (ENs), which select and modulate wavelengths to realize upstream transmission.

In [7], a distributed scheme is presented. In distributed light-path restoration in wavelength- routed networks, different restoration operations may compete for the same wavelength on the same link and become blocked though there are still plenty

of idle capacities on the link. In [7], two different wavelength assignment methods within the same framework are presented for lowering such type of blocking for different cases where the original light-path establishment has adopted random and first-fit wavelength assignments respectively.

7.2 Multicast Technology

The optical fibre tree networks are represented by a directed topology tree graph denoted by $T(N, E)$, where N is the number of vertices (nodes) and E the number of direct edges (links) between any two nodes (parents and their children). A multicast request can be represented by a set of $T(v, d)$, where v is the source (root node) and d is the number of destinations (leaf nodes). A multicast tree $Y(N_Y, E_Y)$ is shaped when each multicast request is made. As can be noticed in the tree topology, the number of nodes is N and the number of links in any tree network is $N-1$. Let W represent the number of wavelengths available in a network and let make the wavelengths available in the tree to $W = \{\lambda_1, \lambda_2, \lambda_3 \dots \lambda_n\}$. Each link in the tree has some available wavelength(s) that can be used to transfer data. The sub-trees formatted by the multicast are represented as $Y = \{Y_1, Y_2, Y_3 \dots Y_n\}$. They are different in various algorithms, because they assign different wavelengths in their computation. The algorithms and their performance will be analysed later on this chapter.

7.3 Tree Network Analysing

Tree networks have various structures that depend on their symmetrical implementation or not. The symmetrical tree networks can be designed as a binary, ternary, quaternary, octarnary ...etc. That sequence depends on the number of the child nodes to each parent node. The unary tree can be studied by a linear network only because there is just one child for each parent, in another word there is one source and several destinations in the same bus (fibre). The binary, ternary and quaternary are investigated in this research. The network capacity is calculated and a specific equation for each type of these networks has been proposed in chapter three. The network capacity is assumed in three situations: when the source is just the root node and the destinations are the leaf nodes, the second when the source is

just the root node and all other nodes in the network are destinations, the third when all parent nodes are data sources.

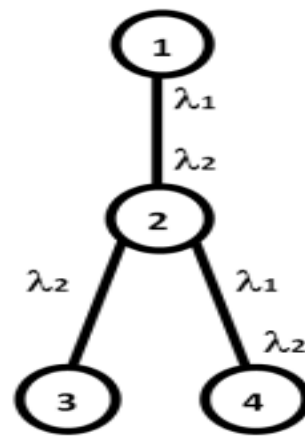

Figure 7-1: Network capacity decreasing

A tree T with h levels is complete if all levels are completely full. The work in this chapter is related to the complete trees.

Network capacity of number of calls is one of the most important factors in any optical fibre network and it is a main purpose for many telecommunication companies and much research. Therefore, the work in this chapter has investigated this term and compared it in different situations. In this step, the network decrease in capacity is described how it occurs in a multicast tree network after each wavelength assignment, and from that, the decrease network capacity can be minimized as much as possible by using our algorithm.

7.3.1 Network capacity

Network capacity represents the number of calls that any network can serve. If a network has served the peak value of calls, then any coming call in will be blocked or put on hold until any other present call is turned off. Therefore, this search for released capacity is used coming to increase network capacity by using special algorithm [8]. Our algorithm will be analysed later on this chapter, but the network capacity is described and calculated in this step.

In the network in figure (7.1), there are availabilities of calls $\{(1, 2), (2, 3), (2, 4), (1, 3)$ and $(1, 4)\}$ using (λ_2) . That means, there are five calls for wavelength (λ_2) available in this network as downstream calls. There are also availabilities of calls

$\{(1, 2), (2, 4) \text{ and } (1, 4)\}$ using (λ_1) . That means, there are three calls for wavelength (λ_1) available in this network as downstream calls. The total network capacity for this network is eight calls. If both downstream and upstream calls are assumed, the number of calls available in this network will be eight either down or upstream. However, we assume the downstream (one direction) calls in our investigation.

7.3.2 Network Capacity decreasing (C_d) in Multicast

The tree T with h levels has n as number of nodes. If we have a call is requested to destination (4), Fig (7.1) and if we assign (λ_1) for the call $\{1, 4\}$, the network capacity will be decreasing $\{(1, 2), (2, 4) \text{ and } (1, 4)\}$, and the result is 3. Whereas, if we assign (λ_2) for the call $\{1, 4\}$, decreasing network capacity will be $\{(1, 2), (2, 4), (1, 4) \text{ and } (1, 3)\}$, and result is 4. Therefore we have to assign (λ_1) instead of (λ_2) to decrease network capacity by 3 instead of 4.

In this step we study the multicast call to the destinations $\{3 \text{ and } 4\}$. If we assign (λ_1) to destination (4) and (λ_2) to destination (3), network capacity will be decreased by the call availabilities $\{(1, 2), (2, 3), (1, 3) \text{ and } (1, 4)\}$ for (λ_2) and $\{(1, 2), (2, 4), (1, 4)\}$ for (λ_1) . That means the decreasing capacity will be seven. If we assign (λ_2) for the destinations $\{3 \text{ and } 4\}$, network capacity will be decreased by the call availabilities $\{(1, 2), (2, 3), (1, 3), (2, 4) \text{ and } (1, 4)\}$. That means the decreasing capacity will be five. Therefore our proposed algorithm assigns (λ_2) instead of $(\lambda_1 \text{ and } \lambda_2)$.

7.3.3 Centralised Wavelength Assignment algorithms

There are many algorithms to allocate an appropriate wavelength to carry data from a source to destinations. The distributed schemes are analysed and described in the previous chapters with different scenarios. In this chapter, the centralised scheme is adopted because of different reasons. Firstly, the costs of the distributed algorithm, which use wavelengths converters, have a significant expense. Secondly, the complexity in the network implementation is due to by wavelength selections, which are distributed in all parent nodes. Thirdly, the energy consumption occurs from the wavelength conversion, which consumes a huge power to convert input power to

other wavelength in output. Therefore, the centralised scheme is analysed in the next steps of this chapter.

7.3.3.1 Highest Number of Destinations (HND) algorithm

Multicast technology in all-optical network gives us an ability to send the same data to multiple-destinations. Using (HND) algorithm is to minimize network capacity which decreases after each wavelength multicast. The objective of our algorithm is to calculate the number of destinations (D_k) the wavelength λ_k can reach. The number of destinations (D_k) for each wavelength is only computed once in the centralized static highest number of destinations (CSHND) algorithm, while in the centralized dynamic highest number of destinations (CDHND), the number of destination (D_k) for each wavelength is calculated after any wavelength assignment. (C_k) is the cost of assigning wavelength (λ_k) to reach these (D_k) destinations.

7.3.3.2 Greedy algorithms performance

Two greedy algorithm's scenarios are investigated [9] (static cost greedy (SCG) algorithm and dynamic cost greedy (DCG) algorithm). (C_k) is the cost of assigning wavelength (λ_k) to reach number of destinations. The wavelength cost ratio (ϕ_k) for each wavelength is only computed once in the static cost greedy (SCG) algorithm. In the dynamic cost greedy (DCG) algorithm, the wavelength cost ratio is dynamically updated each time after each wavelength selection. The cost ratio can be calculated by the equation below:

$$\phi_k = \frac{C_k}{\eta_k} \quad (7.1)$$

(ϕ_k) is the wavelength cost ratio for (λ_k).

(η_k) is the maximum number of destinations that wavelength (λ_k) can reach in the multicast tree.

(C_k) is the cost of assigning wavelength (λ_k) to reach these (η_k) destinations.

Different tree networks have been designed that explain the (HND) algorithm performance compared with greedy algorithms in [9] and how they decrease network

capacity. The HND algorithm has been assumed as centralized algorithm in this step to be equitable when it is compared with the centralized greedy algorithms.

The centralized technologies mainly depend on the wavelength continuity constraint which means that the wavelength is available along the path from the source to the destinations. The wavelength continuity constraint is usually used when the wavelength conversion is required to be reduced, because the wavelength continuity constraint does not need any wavelength conversion through its operation. Therefore, it has been widely used in the passive optical networks.

7.3.3.3 Network Capacity Decreasing (C_d) calculation

The decrease a network capacity and the difference between the centralized and distributed technology will be analysed here, using mathematic analysis. The tree network has many sub trees, $T = (S_1, S_2, S_3, S_4, \dots, S_n)$, where n is the number of wavelengths in the main tree. Network capacity is as defined in equation (1) and depends on the number of paths and available wavelengths to each node. [2]

$$c_p = \sum_{N=1}^p PW \quad (7.2)$$

Where, P is number of paths to all nodes in the network, W is the number of available wavelengths.

We can specify sub-trees related to its wavelength assignment cost and these will be $(S_{\emptyset 1}, S_{\emptyset 2}, S_{\emptyset 3}, S_{\emptyset 4}, \dots, S_{\emptyset n})$

Where:

$$S_{\emptyset 1} \leq S_{\emptyset 2} \leq S_{\emptyset 3} \leq S_{\emptyset 4} \leq \dots S_{\emptyset n} \quad (7.3)$$

The decrease in network capacity can be calculated in the centralized method by finding:

$$S_{\emptyset 1} \cup S_{\emptyset 2} \cup S_{\emptyset 3} \cup S_{\emptyset 4} \cup \dots S_{\emptyset n} \quad (7.4)$$

If we specify every sub-tree by its paths to destinations, the sub-trees will be:

$$S_{\emptyset 1} = (S_{P_1}, S_{P_2}, S_{P_3} \dots S_{P_n}), \quad S_{\emptyset 2} = (S_{P_1}, S_{P_2} \dots S_{P_n}), \dots S_{\emptyset n} \quad (7.5)$$

Where (D) is number of destinations and (L) is the number of links.

$$P_1 = (L_1, L_2, L_3, \dots L_n), P_2 = (L_1, L_2, L_3, \dots L_n) \quad (7.6)$$

Therefore centralised wavelength assignment will decrease network capacity with all united paths in the sub-trees. The decrease in network capacity (C_d) for the algorithms computation will be:

$$Cd = Cp - [S_{\emptyset 1} \cup S_{\emptyset 2} \cup (S_{\emptyset 2} \cap S_{\emptyset 1}) \cup S_{\emptyset 3} \cup (S_{\emptyset 3} \cap S_{\emptyset 1}) \cup (S_{\emptyset 3} \cap S_{\emptyset 2}) \dots S_{\emptyset n}] \quad (7.7)$$

The distributed network method will account for the number of links. Distributed wavelength allocation will decrease network capacity with all links between the sub-trees and therefore we have to specify sub-trees according to their links:

$$\{S_{\emptyset 1} = (L_1, L_2, L_3 \dots L_n), S_{\emptyset 2}(L_1, L_2, L_3 \dots L_n), \dots S_{\emptyset n}\} \quad (7.8)$$

Where, (L) is the links in the sub-tree.

Therefore the decrease in network capacity (C_d) in a network using distributed algorithm, will be the same equation (eq. (3.6)) for the centralized algorithm but this depends on the number of links in the network.

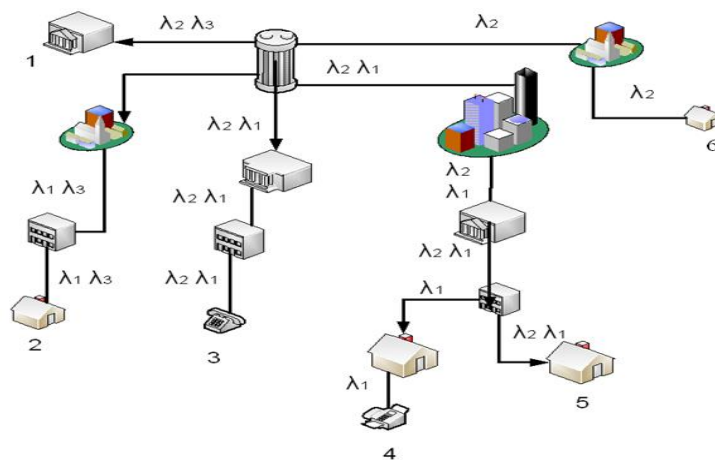

Figure 7- 2: Part of quaternary tree network show network capacity decreasing

7.3.3.4 HND works better than DCG and SCG

If there are calls to all destinations (1, 2, 3, 4, 5 and 6) in figure 7.2 the performance will be as follow:

HND algorithm accounts for the number of destinations for each wavelength ($D1 = 4, D2 = 4, D3 = 2$). Therefore it allocate (λ_1) as the first wavelength that have the highest number of destinations to (2, 3, 4, 5) and (λ_2) to (1, 6). That means the decreasing network capacity will be 31 for (λ_1) and 4 for (λ_2) and the total will be 35.

SCG algorithm accounts for the cost ratio for each wavelength ($\phi_1 = \frac{31}{4} = 7.75, \phi_2 = \frac{20}{4} = 5, \phi_3 = \frac{7}{2} = 3.5$). Therefore it allocates (λ_3) to (1, 2), (λ_2) to (3, 5 and 6) and (λ_1) to (4). The decreasing network capacity will be 7 for (λ_3), 19 for (λ_2) and 15 for (λ_1) and the total will be 41.

DCG selects (λ_3) to (1 and 2), and it calculates the cost ratio again for the remaining wavelengths and they will be ($\phi_1 = \frac{25}{3} = 8.333, \phi_2 = \frac{219}{3} = 6.333$). Therefore it chooses (λ_2) to (3, 5 and 6) and (λ_2) to (4) and the performance of DCG will be exact same as SCG. The decreasing network capacity will be 7 for (λ_3), 19 for (λ_2) and 15 for (λ_1) and the total will be 41.

The other advantage of HND is the number of utilised wavelengths that is reduced. HND has used two wavelengths while SCG and DCG has utilised three wavelengths in this example.

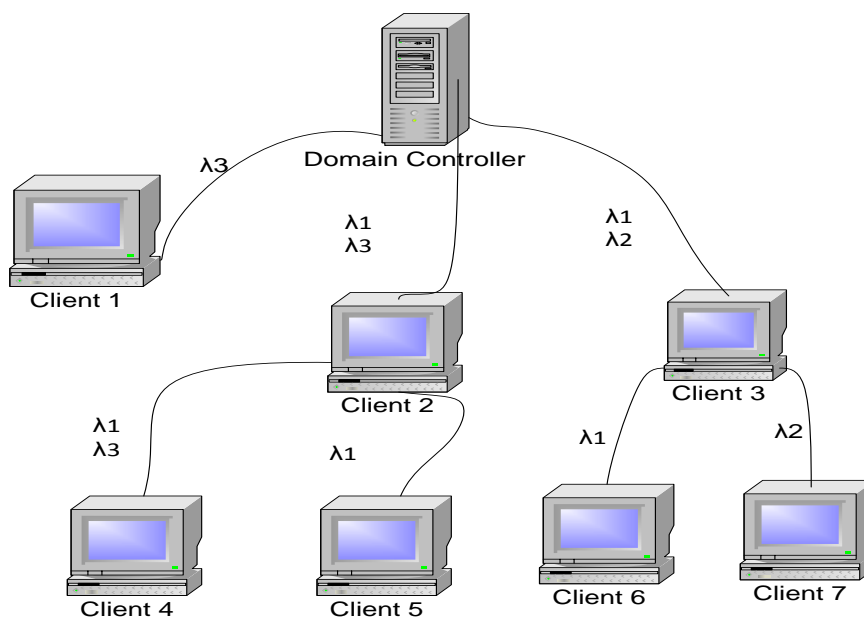

Figure 7- 3: Part of ternary tree network show the capacity decreasing

If there are calls to all destinations (1, 4, 5, 6 and 7) in figure 7.3 the performance will be as follow:

HND algorithm accounts for the number of destinations for each wavelength ($D1 = 3$, $D2 = 1$, $D3 = 2$). Therefore it allocates (λ_1) as the wavelength that has the highest number of destinations to (4, 5, 6), (λ_3) to (1) and (λ_2) to (7). That means decreasing network capacity will be 8 for (λ_1), 1 for (λ_3) and 3 for (λ_2) the total will be 12.

SCG algorithm accounts for the cost ratio for each wavelength ($\phi_1 = \frac{8}{3} = 2.67$, $\phi_2 = \frac{3}{1} = 3$, $\phi_3 = \frac{4}{2} = 2$). Therefore it allocates (λ_3) to (1, 2), (λ_2) to (3, 5 and 6) and (λ_1) to (4). The decreasing network capacity will be 7 for (λ_3), 19 for (λ_2) and 15 for (λ_1) and the total will be 41.

DCG selects (λ_3) to (1 and 2), and it will calculate cost ratio again for the remaining wavelengths and they will be ($\phi_1 = \frac{25}{3} = 8.333$, $\phi_2 = \frac{219}{3} = 6.333$). Therefore it chooses (λ_2) to (3, 5 and 6) and (λ_2) to (4) the performance of DCG will be exact same as SCG. The decreasing network capacity will be 7 for (λ_3), 19 for (λ_2) and 15 for (λ_1) and the total will be 41.

7.4 Results and Discussion

By using numerical calculation for the decreasing network capacity test as shown in Figures 7.4, 7.5 the improvement is clear between the HND algorithm scenarios and the cost greedy algorithm (CG) scenarios. In the first graph figure 7.4 the simulation is for a binary tree with three levels, four wavelengths, eight destinations, fifteen nodes and two wavelengths available to each destination, while the simulation in Figure 7.5 shows the result for a ternary network with three levels and consist of forty nodes, twenty seven destinations, four wavelengths and two wavelengths available to each destination. The network capacity performance relating for the DCG and CSHND is about the same. The CDHND scenario has the best performance among all other technologies.

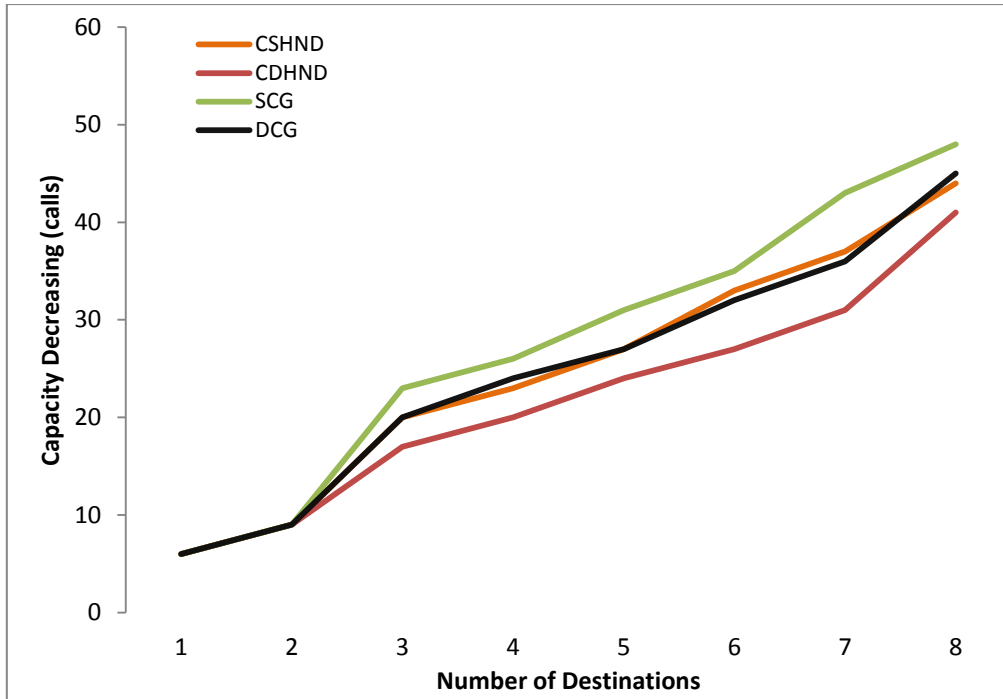

Figure 7- 4: Capacity Decreasing in Binary network

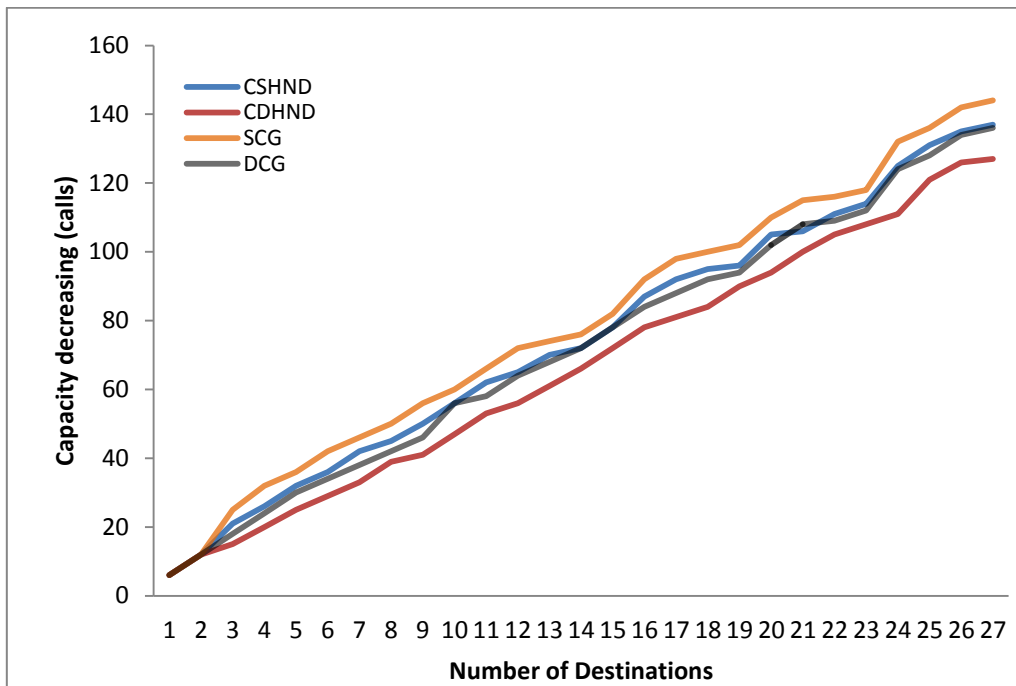

Figure 7- 5: Capacity Decreasing in Ternary network

The network capacity decreasing is shown in Figure 7.2. The simulation for a ternary network, Figure 7.5, has the same parameters of the binary network but the difference is just in the network size as shown in Figure 7.5. The time delay for our algorithm with the static scenario (CSHND) has the smallest value. The performance of the CDHND and SCG is very near. The distributed scenario of our proposed

algorithm has the least value of the all centralized algorithms and scenarios. Therefore, distributed scenario will be used for our future work.

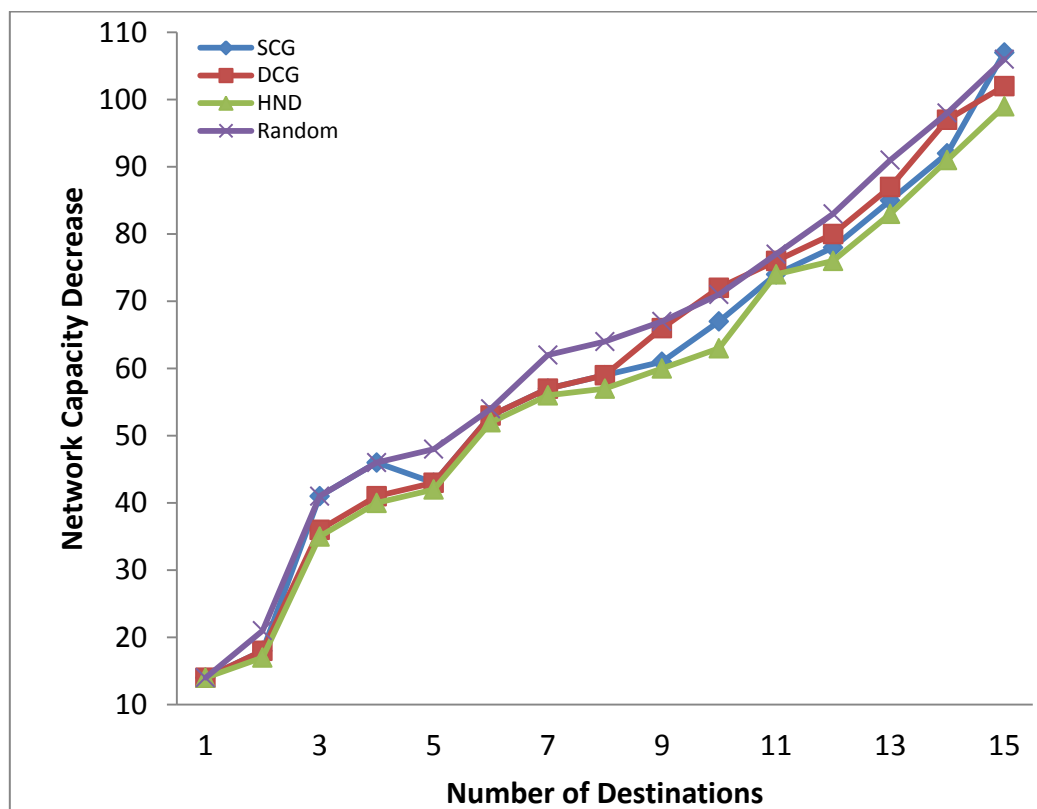

Figure 7- 6: Capacity Decreasing in Random tree

7.5 Summary

The centralized algorithm is proposed and investigated in this chapter. There are two scenarios that are assumed for our algorithm. Passive optical network is of high worth in telecommunication networks because of the energy saving and green technology. Therefore, our algorithm is proved to be suitable for the passive optical networks. The network capacity and the number of calls in any communication network are extremely important. Our algorithm has improved network capacity, and it saved the network capacity decreasing after each assignment of a wavelength. The decreasing network capacity is compared with a greedy algorithm and the result proved of our algorithm. The network trees have been chosen with an order coordinator and they were not chosen randomly as in most of other researches. The network capacity is formulated with mathematical equations (3.37, 3.55, 3.70, 7.4 and 7.7) in our work and these equations are published in the first time to our knowledge.

References

- [1] Physorg.com, Proved by Alcatel-Lucent, September 29, 2009, Physorg.com [online] available from: <http://physorg.com/news173455192.html>. [Accessed 9 May 2012].
- [2] Yu-Li Hsueh, Matthew S. Rogge, Shu Yamamoto, and Leonid G. Kazovsky, "A Highly Flexible and Efficient Passive Optical Network Employing Dynamic Wavelength Allocation, *Journal of Lightwave Technology*, vol. 23, No. 1, pp. 277-286, January 2005.
- [3] Keri, M.; Oki, E.; Matsuura, M.; "Wavelength Assignment in Multi-Carrier Distributed Optical Ring Networks with Wavelength Reuse," *Optical Communications and Networking, IEEE/OSA Journal of*, vol.3, no.4, pp.281-289, April 2011.
- [4] Jun He; Brandt-Pearce, M.; Subramaniam, S.; , "QoS-Aware Wavelength Assignment With BER and Latency Constraints for All-Optical Networks," *Lightwave Technology, Journal of* , vol.27, no.5, pp.462-474, March1, 2009.
- [5] Azodolmolky, S.; Perelló, J.; Angelou, M.; Agraz, F.; Velasco, L.; Spadaro, S.; Pointurier, Y.; Francescon, A.; Saradhi, C.V.; Kokkinos, P.; Varvarigos, E.; Al Zahr, S.; Gagnaire, M.; Gunkel, M.; Klondis, D.; Tomkos, I.; , "Experimental Demonstration of an Impairment Aware Network Planning and Operation Tool for Transparent/Translucent Optical Networks," *Lightwave Technology, Journal of* , vol.29, no.4, pp.439-448, Feb.15, 2011.
- [6] Jian Liu; Gaoxi Xiao; "Efficient Wavelength Assignment Methods for Distributed Lightpath Restorations in Wavelength-Routed Networks," *Lightwave Technology, Journal of*, vol.27, no.7, pp.833-840, April1, 2009.
- [7] Triay, J.; Cervello-Pastor, C., "An ant-based algorithm for distributed routing and wavelength assignment in dynamic optical networks," *Selected Areas in Communications, IEEE Journal on*, vol.28, no.4, pp.542-552, May 2010.
- [8] Sabbar Abbas, Rafed; Al-Raweshidy, Hamed Saffa; Radhi, Nazar; Alabdulkreem, Eatedal, "New multicast switch and algorithm to increase network capacity," *International Conference on Telecommunications (ICT)*, 2012 19th, vol., no., pp.1-6, 23-25 April 2012.

- [9] Jianping Wang; Biao Chen; Uma, R.N.; , "Dynamic wavelength assignment for multicast in all-optical WDM networks to maximize the network capacity," Selected Areas in Communications, IEEE Journal on , vol.21, no.8, pp. 1274-1284, Oct. 2003.

Chapter Eight

Conclusion and Future Work

8.1 Conclusion

Wavelengths allocation in WDM optical network is investigated in this thesis. There are various algorithms adopted to choose appropriate wavelength to the required incoming or produced call. Wavelengths' assignment has faced several challenges especially wavelengths' selection and routing. The topologies have differed from one to another research, some of research works have adopted mesh networks, other has embraced ring networks and other has fostered tree networks. There are also other network topologies such as bus, star and linear networks. The topology that is utilised in this thesis is the tree network. The tree networks have different designs such as random and m-arity tree networks, while the second one is adopted in this research.

8.1.1 m-arity tree networks

The m-arity tree networks (binary, ternary, quaternary...etc.) are investigated in this work to find its related parts. The number of nodes, number of links and number of leaves nodes are calculated and their equations are derived. Number of needed wavelengths to feed all destinations is calculated related to the network arity and level of the m-arity tree network. The relationships between all of these parts are found in driven equations. The equations are started from binary tree networks and through ternary and quaternary tree networks until they are generalised to the all m-arity networks.

Three cases are analysed for the m-arity tree networks and their equations are derived. Firstly, the networks that have one source and just the leaves nodes are destinations. Secondly, the networks that have one source and all other nodes are destinations. Thirdly, the tree networks that have all nodes are sources and destinations at the same time.

8.1.2 Multicast switching

The data transmission has different scenarios such as uni-cast (sending data from one source to one certain destination), multicast (sending data from one source to a particular number of destinations) and broadcast (sending data from one source to all destinations). Multicast switching is one of the most important issues in the multicast scheme in the telecommunication technology. C-S-C-S multicast switch is proposed in this thesis and compared with two other switches. The presumed multicast switch has maintained the transmitted signal's power to a huge amount compared with other multicast switches while the transmitted signal is the same with same conditions in all compared switches. The performance of the suggested switch is concentrated on minimizing the conversion range, using four-wavelength-mixing conversion technology and takes advantage of the amplification in the other converters by connecting them in series and not in parallel. The optimization is increased by about 14.8% using binary tree network and up to 28% using octonary tree network, compared with other switches. One more advantage of using C-S-C-S multicast switch is the low group delay which is caused by signals traveling throughout many devices. The group delay is reduced by about 5.7% and 34.1% compared with other two switches using binary network, until reaching about 13% and 28% using octonary tree network.

8.1.3 Distributed Wavelengths Selection

Wavelength selection is a technology to choose an appropriate wavelength to carry data from source to destination. Distributed and centralised schemes are two methods to be utilized to assign a convenient wavelength. There are various distributed algorithms proposed to allocate wavelengths. Shortest Wavelength Assignment (SWA) algorithm and Highest Number of Destinations with Shortest Wavelength Assignment (HND-SWA) algorithm are distributed algorithms are suggested in this thesis to increase the received signal's power, reduce group delay and decrease dispersion. The proposed algorithm performance concentrates on assigning the shortest wavelength because of its high power and low dispersion. The SWA algorithm has almost better performance compared with the HND-SWA algorithm for to the power, group delay and dispersion. The networks are that used

to prove the performance of these algorithms are different such as m-arity and random tree networks.

The proposed two algorithms have been investigated to find the number of wavelength converters and wavelengths required in their operation. The HND-SWA algorithm has optimized the performance by reducing the number of utilised wavelengths up to about 19% in the whole network and minimizing number of the used wavelengths converters up to about 29% using random tree network. It made optimisations by about 11% and 28% for the number of wavelengths and wavelengths converters respectively by using quaternary tree network. The HND-SWA algorithm has recorded almost the best performance related to the WN and WCN compared with the other algorithms.

8.1.4 Centralised Wavelengths Selection

Centralised scheme in wavelength assignment technology has been proposed also to examine network capacity decreasing (C_d) after each wavelength assignment. The (C_d) is an important parameter to reduce call blocking. The HND algorithm has been put forward into two scenarios CSHND and CDHND, which differed in their dynamic or static calculation of the number of destinations of each wavelength. CDHND has recorded the best performance by reducing C_d by about 16.7% and 11.8% using binary and quaternary tree networks.

8.2 Future Works

Many issues still need to be researched and investigated. The research time is limited whilst ideas are expanded and are more and more with time. A brief summary of the next ideas for the future are listed below.

- a. Dispersion for the C-S-C-S compared with other multicast switches need to be investigated. The networks need to be expanded to a bigger network.
- b. Wavelengths conversion cost can be calculated by finding the conversion degree and converters' number which has to be reduced in the next steps of the future work for the multicast switches.

- c. An idea can be investigated and implemented to reduce wavelengths conversion degree by utilising a circulator to take advantage of its multiple entries and multiple outputs .
- d. The components are really expensive and therefore any work starts with software and is then implements in hardware. The hardware implementation will be in the future especially when the software recorded the successful optimization.
- e. The multicast algorithms has been examined by using one wavelength assignment algorithm and they need to be investigated by using different algorithms and that will make sense of the huge difference between C-S-C-S multicast switch using HND-SWA algorithm with switches using their wavelengths allocation algorithms.
- f. There is an intelligent idea about the centralised wavelengths assignment algorithm that can be implemented in future. It called nearest relative algorithm which can assign wavelength that can reach the nodes that are in the same branch and sub-branch.
- g. The other algorithm is to calculate the ratio of the number of children each wavelength can reach to the number of children after each wavelength allocation. That will help to reduce the decrease in network capacity and work is already started with this algorithm and will be published in a paper soon.
- h. Blocking probability is a direct outcome caused when a network capacity is full. Therefore, algorithms, which have reduced the decrease in network capacity after each assignment, will obviously decrease blocking probability. That can be calculated in future also.
- i. Our future work will compare the distributed and centralised algorithms performances.

List of Publications

- 1) N. Radhi 1, K. Aziz 2, R. S. Abbas³, H. AL-Raweshidy; , "Cyclostationary Detection in Spectrum Pooling System of Undefined Secondary Users", *IEEE The Seventh International Conference on Wireless and Mobile Communications (ICWMC)*, pp. 266-270, 2011.
- 2) Alfredo Viglienzoni, Hamed Al-Raweshidy, "Next Generation Network: Wireless-Optics Technologies", White Paper, Net!Works European Technology Platform, 2011, vol. 13, available online [accessed on] 08/December/2011, http://www.networks-etp.eu/fileadmin/user_upload/Publications/Position_White_Papers/White_Paper_RoF.pdf
- 3) Abbas, R.S.; Al-Raweshidy, H., "New multicast switch-based multicast wavelength allocation algorithm to increase network capacity," *IEEE International Conference on Future Communication Networks (ICFCN), 2012*, vol., no., pp.164-169, 2-5 April 2012.
- 4) Sabbar Abbas, Rafed; Al-Raweshidy, Hamed Saffa; Radhi, Nazar; Alabdulkreem, Eatedal, "New multicast switch and algorithm to increase network capacity," *IEEE International Conference on Telecommunications (ICT), 2012 19th*, vol., no., pp.1-6, 23-25 April 2012.
- 5) Rafed Sabbar Abbas, Hamed Saffa Al-Raweshidy, "A New Centralized Multicast Wavelength Allocation Algorithm in Optical Fiber Network", *International Journal of Soft Computing and Software Engineering (JSCSE)*, vol. 2, no. 11, pp. 13-19, Nov. 2012.
- 6) Rafed Sabbar Abbas, Hussien Al-Hmood, Saman Hameed Amin, H.S. Al-Raweshidy, "A Distributed Algorithm in WDM Network to Increase Network Capacity and Minimize Conversion Range ", *International Journal of Advances in Engineering Science and Technology (IAEST)*, vol. 2, no. 2, pp. 137-143, Apr. 2013.

- 7) A. Masrub, R.S. Abbas, H. Al-Hmood, M. Iqbal and H.S. Al-Raweshidy, "Cooperative Sensing for Dynamic Spectrum Access in Cognitive Wireless Mesh Networks", *IEEE International Symposium On Broadband Multimedia System Broadcasting (BMSB)*, vol., no., pp., 4-7 Jun 2013.
- 8) Rafed Sabbar Abbas, A. Masrub, Saman Hameed Amin, H.S. Al-Raweshidy, High QoS and Low Cost Wavelength Allocation Protocol in Optical Network Using Multicast Technology, *IEEE Third International Conference on innovative Computing Communication Technology (INTECH 2013)*, vol., no., pp., 29-31 Aug 2013.
- 9) Al-Hmood, H.; Abbas, R.S.; Masrub, A.; Al-Raweshidy, H.S., "An estimation of primary user's SNR for spectrum sensing in cognitive radios," *Innovative Computing Technology (INTECH), 2013 Third International Conference on* , vol., no., pp.479,484, 29-31 Aug. 2013
- 10) Saman Hameed Amin, H.S. Al-Raweshidy, Rafed Sabbar Abbas, Smart data packet ad hoc routing protocol, *Computer Networks*, vol. 62, pp. 162-181, 7 April 2014.
- 11) Rafed Sabbar Abbas, H. Al-Raweshidy, "Number of wavelengths required in M –arity tree networks", *ELECTRONICS LETTERS 20th November 2014 Vol. 50 No. 24 pp. 1855 – 1857*

Submitted papers

- 1) Rafed Sabbar Abbas, H. Al-Raweshidy, "Wavelengths Multicast Switching in WDM Optical Tree Network to Increase QoS", in *The Journal of Engineering*. Manuscript ID is: JOE-2014-0232.