

1 **Optimal PMU Placement using Topology**

2 **Transformation Method in Power Systems**

3
4 Nadia H. A. Rahman, Ahmed F. Zobaa*

5 Brunel University London, College of Engineering, Design and Physical Sciences, United Kingdom

6 * Corresponding author: T +44 (0)1895 265335 | F +44 (0)1895 269782, azobaa@ieee.org

7 Short running title: OPP using Topology Transformation Method

8

9 **Abstract** - Optimal phasor measurement units (PMUs) placement involves the process of
10 minimizing the number of PMUs needed while ensuring the entire power system completely
11 observable. A power system is identified observable when the voltages of all buses in the
12 power system are known. This paper proposes selection rules for topology transformation
13 method that involves a merging process of zero-injection bus with one of its neighbors. The
14 result from the merging process influenced by the selection of bus selected to merge with the
15 zero-injection bus. The proposed method will determine the best candidate bus to merge with
16 zero-injection bus according to the three rules created in order to determine the minimum
17 number of PMUs required for full observability of the power system. In addition, this paper
18 also considered the case of power flow measurements. The problem formulated as integer
19 linear programming (ILP). The simulation for the proposed method tested by using
20 MATLAB for different IEEE bus systems. The explanation of the proposed method is
21 demonstrated by using IEEE 14-bus system. The results obtained in this paper proved the
22 effectiveness of the proposed method since the number of PMUs obtained are comparable
23 with other available techniques.

24

25 **Keywords:** Integer linear programming; Phasor measurement unit; Power flow
26 measurements; Power system measurements; Topology, Zero-Injection Bus

27

28 **Introduction**

29 As shown in the biggest blackout in North American history, one of the factors that caused
30 the incident was the lack of real-time data gathering during the incident. This prevented the
31 necessary steps from being taken before the incident happened, leading to the catastrophic
32 blackout. Fifty million people in eight US states and two Canadian provinces were affected
33 by the incident [1].

34 Following that incident, phasor measurement unit (PMU) became an interesting solution
35 because of its ability to be used as a measurement tool that can provide synchronized phasor
36 measurements [2]. Synchronized phasor measurements are achieved using the Global
37 Positioning System (GPS), which makes it possible to obtain real-time data down to the
38 microsecond [3, 4]. This knowledge encourages better monitoring of a power system because
39 it allows one to detect, anticipate, and correct problems during irregular system conditions
40 [2]. Hence, an efficient operation of power system increased by having a PMU installed in it.
41 In spite of the fact that PMU can improve the monitoring of a power system, the cost of the
42 PMU itself limits the number of PMUs that one can consider to install in the power system.
43 Furthermore, it is not necessary to install PMU at all buses since the voltage phasor of the bus
44 incident to the PMU installed bus can be computed with branch parameter and branch current
45 phasor measurement [7, 8]. Thus, it proves by having optimal placement of PMUs in power
46 system sufficient to make the whole network observable [5, 6]. However, this has not stopped
47 the growth of interest for the development of PMU-based applications [9]. PMU applications
48 for transmission system operation and control considered mature in recent years [10]. This
49 has further encouraged engineers and researchers to find the best algorithm and method to
50 identify the optimal PMU placement (OPP) in the power system for the intended PMU
51 applications.

52 The PMU placement technique using spanning trees of a power system graph was proposed
53 [11], from which the concept of “depth-of-unobservability” was then introduced. The
54 simulated annealing method and graph theory were used to develop an algorithm that
55 managed to minimize the size of the PMU set and ensured the observability of the system
56 [12].

57 **Bei Xu et. al [13]** adopted integer linear programming (ILP) approach which allows easy
58 analysis of network observability for mixed measurement sets based on conventional

59 measurements. It was further enhanced through topology modification by merging the bus
60 that has injection measurement with one of its neighbors [14]. **Bei Gou [15]** introduced a
61 simpler algorithm that was then revised for the cases of redundant PMU placement, full
62 observability and incomplete observability [16]. **Dua et al [17]** and **Abbasy et al [18]**
63 overcome a single PMU loss by multiplied inequalities for every constraint with two which
64 ensure every bus will be monitored by at least two PMUs. Meanwhile, measurement
65 redundancy was considered and extended it to consider a practical limitation on the
66 maximum number of PMU channels [19]. Branch and bound (B&B) method was **proposed**
67 **by Mohammadi-Ivatloo et al [20]** to solve an OPP problem considering secondary voltage
68 control. Nonlinear constraints were formed when considering an adjacent zero-injection bus
69 based on the hybrid topology transformation. Differential evolution (DE) optimization was
70 adopted **by Al-Mohammed et al [21]** to solve the OPP problem. **Chakrabarti et al [22]** used
71 exhaustive search (ES) algorithm where the authors claimed it gave better results than the
72 method used **by Bei Xu et al [13]** based on the uniform measurement redundancies obtained
73 in the results. Mixed integer linear programming (MILP) was used to solve the OPP problem
74 by considering PMU placement and maximum redundancy of the system simultaneously with
75 the maintenance of system reliability [23]. Binary particle swarm optimization (BPSO)
76 method was used in **the research made by Ahmadi et al [24]** and **Rather et al [25]**, which is an
77 extension of the conventional particle swarm optimization (PSO) method to solve OPP
78 problems. PSO is a population-based search algorithm based on simulation of the social
79 behavior of birds within a flock [26]. The two researches adopted different approaches:
80 **measurement redundancy [24]; measurement redundancy and cost [25].**

81 The existence of zero-injection bus can also help reduce the number of PMUs needed. Most
82 of the studies adapted merging method to deal with ZIB. However, there are two limitations
83 when using merging method which are to identify the exact PMUs placement and the

84 importance of selecting the right bus to merge. Hence, this paper proposes three rules to
85 overcome these limitations. The three rules developed will evaluate the best candidate bus to
86 merge with ZIB. The results obtained using the proposed method will give a definite PMU
87 placement location. Additionally, the existence of power flow measurements is also adopted
88 with the proposed method. Note that, the discussion made in this paper only involves PMU
89 measurements. SCADA measurements are not considered in this paper.

90 This paper organized into seven sections including this section. Section 2 presents the
91 objective function for PMU placement problem. Section 3 explores the PMU placement rules
92 to determine the topological observability of power system. A detailed explanation of the
93 proposed method explained in Section 4. Section 5 presents the case study for the proposed
94 method by using IEEE 14-bus system. The simulation results obtained from MATLAB
95 software for each IEEE bus systems presented in Section 6. Each result and the flow of the
96 program highlighted in this section to ensure better understanding of the method presented.
97 Section 7 concludes this paper by highlighting the key elements and the contribution of this
98 paper.

99

100 **PMU Placement Formulation**

101 The objective in the OPP is to find the minimum number of PMUs required and its location
102 in the power system to achieve full network observability. Thus, the objective function is
103 formulated as below:

$$\min \sum_{k=1}^N x_k \quad (1)$$

subject to: $[A] \times [X] \geq [b]$

104 where N is a number of system buses and $[A]$ is a binary connectivity matrix. Entries for
 105 matrix $[A]$ defined as follows:

$$A_{i,j} = \begin{cases} 1 & \text{if } i = j \\ 1 & \text{if } i \text{ and } j \text{ are connected} \\ 0 & \text{if otherwise} \end{cases} \quad (2)$$

106 Meanwhile $[X]$ is defined as a binary decision variable vector
 107 where $[X] = [x_1 \ x_2 \ x_3 \ \dots \ x_N]^T$ and $x_i \in \{0,1\}$:

$$x_i = \begin{cases} 1 & \text{if a PMU is installed at bus } i \\ 0 & \text{otherwise} \end{cases} \quad (3)$$

$$[b] \text{ is a column vector where } [b] = [1 \ 1 \ 1 \ \dots \ 1]_{1 \times N}^T \quad (4)$$

109

110 **PMU Placement Rules**

111 There are two types of observability analysis used to analyze the power system, which are
 112 numerical and topological observability. In this paper, a topological observability analysis is
 113 used. A power system achieves full observability if all buses in it are observable. A bus in the
 114 power system is identified as observable if its voltage can be directly or indirectly measured
 115 by using pseudo-measurements [27].

116 The ability of PMU to measure the voltage phasor at the installed bus and the current
 117 phasor of all the branches connected to the PMU installed bus can help determine the
 118 remaining parameters to use for indirect measurements. By using Ohm's law and Kirchhoff's
 119 Current Law (KCL), bus adjacent to PMU installed bus can have its voltage phasor and
 120 branch currents value known. Following are the PMU placement rules to identify bus as
 121 observable:

Rule 1 A bus that has a PMU installed on it will have its voltage phasor and all
 branches currents incident to it measured by the PMU.

Rule 2 By applying Ohm's law, the voltage phasor at one end of a branch current can be calculated if voltage phasor at the other end of branch current is known.

Rule 3 If the voltages at both ends of a branch are known, the branch current can be computed by using Ohm's law

122 In order to explain how these rules work, consider Fig. 1(a). If a PMU is placed on bus 1,
123 the voltage phasor of bus 1 and the branch currents between 1-2 and 1-3 can be obtained
124 (using Rule 1). Since branch 1-2 and 1-3 are now observed and are connected to the
125 observed bus (bus 1), the voltage of bus 2 and 3 can be observed (Rule 2). By observing bus
126 2 and 3, branch current 2-3 can be observed (Rule 3).

127 A ZIB is another factor that can possibly reduce the number of PMUs required to achieve
128 complete observability. There is no generator that injects power or a load that consumes
129 power from this bus [9]. The sum of flows on all branch currents associated with ZIB is zero
130 according to KCL. Network observability can be assessed with the presence of ZIB based on
131 the rules below [29, 30]:

Rule 4 When buses incident to an observable ZIB are all observable except one, the unobservable bus can be identified as observable by applying the KCL at the ZIB

Rule 5 When buses incident to an unobservable ZIB are all observable, the ZIB will be identified as observable by applying the node equation

Rule 6 A group of unobservable ZIB which is adjacent to observable buses will be identified as observable by obtaining the voltage phasors of ZIB through the node equation

132 To explain these rules, consider Fig. 1(b). Bus i is a ZIB that incident to bus $\{1, 2, 3, 4\}$.
133 For rule 4, consider that bus $\{i, 2, 3, 4\}$ are observable and bus 1 is unobservable. By

134 applying KCL at bus i , branch current $i-1$ can be calculated. For rule 5, consider bus $\{1, 2, 3,$
135 $4\}$ are observable and bus i is unobservable. By applying the node equation in this situation,
136 voltage phasor of bus i can be calculated. For rule 6, consider Fig. 1(c), where all buses are
137 incident to the ZIB, bus $\{i, j\}$ are observable. By using the node equation, both voltage
138 phasors of bus $\{i, j\}$ can be calculated. These rules allow buses incident to the ZIB to be
139 observable without the need of placing a PMU on it. Therefore, it helps reduce the number of
140 PMUs to be placed in the power system.

141 Power flow measurement can be used to determine other parameters in the power system. It
142 allows one to determine other quantities provided certain quantities are known [31]. When
143 power flow measurements are present, the voltage at the other end can be calculated by
144 taking all the known real and reactive power flows at each bus including the voltage [2, 27,
145 28]. Previous studies have found that incorporated power flow measurement and ZIB
146 together will further reduced number of PMUs needed. To reach this objective, the method
147 proposed by Bei Xu et al [13] was used to deal with the existence of power flow
148 measurement. According to research made by Bei Xu et al [13], the constraints involved with
149 power flow measurement will be altered. The combination method introduced by Bei Xu et al
150 [13] and the authors' proposed method will be incorporated when dealing with the OPP for
151 the case of considering power flow measurement and ZIB.

152

153 **Proposed Method**

154 Topology transformation method involves the merging process of ZIB and one of its
155 neighbors. This means the number of buses in a power system will be reduced by one for
156 each available ZIB. Furthermore, the merging process causes the network topology of a
157 power system to be modified and network equations need to be redefined to reflect the
158 changes. As stated by Abbasy et al [18], the result from the merging process is different for
159 each candidate bus available to merge with ZIB. The authors did not elaborate further how
160 each merged bus was selected. In addition, if the results require a PMU to be placed at the
161 merged bus, it is possible for the PMU to be placed at the original ZIB or at the bus it is
162 merged with, or at both buses. These are the limitations that the proposed method will
163 address by selecting the best candidate bus to merge with ZIB and to provide the exact
164 location for PMU placing.

165 The proposed method considered the existence of ZIB and radial bus in a power system.
166 Radial bus is referring to bus that has only one adjacent bus connected to it. Placing a PMU at
167 a radial bus will ensure a maximum of two bus to be observed which is radial bus and its
168 neighbor. Meanwhile placing a PMU at a bus that is adjacent to radial bus will ensure more
169 than two bus observable. Thus, to ensure better network coverage, a PMU will be pre-
170 assigned at a bus that is adjacent to radial bus. The proposed method consists of three rules
171 for which every candidate bus will be evaluated in sequence. Following are the three rules:

172 **1) Rule A:** Merge ZIB with its adjacent bus that is radial bus

173 In the case where ZIB is incident to a radial bus, the merging process will take place
174 between both buses. In the situation where after the merging process, the merged bus is
175 connected to two or more buses, a PMU does not need to be pre-allocated. Meanwhile, if the
176 merged bus is connected to two buses and one of them is a ZIB, a PMU must be pre-allocated
177 to a bus that is not a ZIB.

178 Consider Fig. 2(a), where bus i is a ZIB and bus 2 is a radial bus. Bus 2 will be selected to
179 merge with bus i . Bus {1, 3} will be connected to bus 2' after the merging process and bus i
180 is removed from the network. Since neither bus 1 nor bus 3 is a ZIB, it is not necessary to
181 pre-allocate a PMU to either of these buses. In the case where bus 3 is a ZIB, a PMU must be
182 pre-allocated at bus 1 to ensure bus 2' is observable.

183

184 **2) Rule B:** If the adjacent bus of ZIB has the most number of bus connected to it, and
185 one of its neighbor bus connected to the same ZIB, this adjacent bus will be selected
186 to merge with the ZIB

187 This is to increase bus tendency to be picked as a PMU placement because of the
188 better network coverage among other buses that are adjacent to the ZIB.

189

190 Consider Fig. 2(b), where bus i is a ZIB that is incident to bus {1, 2, 3}. The outward lines
191 from bus {1, 2, 3} mean it is connected to more buses that are not illustrated in Fig. 2(b), to
192 simplify the diagram. It can be seen that bus 1 is connected to more buses than any other bus
193 that is incident to bus i follow by bus 3. However, since bus 2 and 3 are incident to each other
194 and both are connected to the same ZIB, they will be considered to merge with bus i . To
195 decide whether bus 2 or 3 that will be selected to merge with bus i , the bus that has the
196 maximum number of neighbors among the buses involved will be chosen, and in this case
197 bus 3 is the best candidate to be merged.

198

199 **3) Rule C:** Merge ZIB with its adjacent bus that has the most number of bus connected
200 to it.

201 This scenario encourages better network coverage because it can reach more
202 buses compared to the other adjacent buses when it is selected to merge with the ZIB.

203 Consider Fig. 2(c), where bus i is a ZIB that is incident to bus $\{1, 2\}$. As we can see, bus 1
204 has the maximum number of neighbors compared to bus 2. Hence, it is selected to merge
205 with bus i . Like previous rules explained in this section, bus i is removed from the network
206 after the topology transformation.

207 Note that, in all rules explained above, bus that has been merged is excluded for the next
208 merging process. This means bus can only be merged once and will not be considered as a
209 candidate bus for another merging process. Flowchart depicted in Fig. 3 shows how each bus
210 is evaluated based on the rules above.

211

212 **Case Studies**

213 The effectiveness of the proposed method in solving the OPP problem is presented by
214 using three experimental cases. All cases are elaborated in detail respectively by using IEEE
215 14-bus system illustrated in Fig. 4 and simulated by using MATLAB. Following are the three
216 cases:

217

218 *a) Case I:* Ignoring conventional measurement for full network observability

219

220 For this case, ZIB and power flow measurements are not considered. In addition, no PMU is
221 pre-allocated for the bus that is incident to the radial bus. By using (2), the binary
222 connectivity matrix A is formed as follow:

223

$$[A] = \begin{bmatrix} 1 & 1 & 0 & 0 & 1 & 0 & 0 & 0 & 0 & 0 & 0 & 0 & 0 & 0 & 0 \\ 1 & 1 & 1 & 1 & 1 & 0 & 0 & 0 & 0 & 0 & 0 & 0 & 0 & 0 & 0 \\ 0 & 1 & 1 & 1 & 0 & 0 & 0 & 0 & 0 & 0 & 0 & 0 & 0 & 0 & 0 \\ 0 & 1 & 1 & 1 & 1 & 0 & 1 & 0 & 1 & 0 & 0 & 0 & 0 & 0 & 0 \\ 1 & 1 & 0 & 1 & 1 & 1 & 0 & 0 & 0 & 0 & 0 & 0 & 0 & 0 & 0 \\ 0 & 0 & 0 & 0 & 1 & 1 & 0 & 0 & 0 & 0 & 1 & 1 & 1 & 1 & 0 \\ 0 & 0 & 0 & 1 & 0 & 0 & 1 & 1 & 1 & 0 & 0 & 0 & 0 & 0 & 0 \\ 0 & 0 & 0 & 0 & 0 & 0 & 1 & 1 & 0 & 0 & 0 & 0 & 0 & 0 & 0 \\ 0 & 0 & 0 & 1 & 0 & 0 & 1 & 0 & 1 & 1 & 0 & 0 & 0 & 0 & 1 \\ 0 & 0 & 0 & 0 & 0 & 0 & 0 & 0 & 1 & 1 & 1 & 0 & 0 & 0 & 0 \\ 0 & 0 & 0 & 0 & 0 & 1 & 0 & 0 & 0 & 1 & 1 & 0 & 0 & 0 & 0 \\ 0 & 0 & 0 & 0 & 0 & 1 & 0 & 0 & 0 & 0 & 0 & 1 & 1 & 1 & 0 \\ 0 & 0 & 0 & 0 & 0 & 1 & 0 & 0 & 0 & 0 & 0 & 1 & 1 & 1 & 1 \\ 0 & 0 & 0 & 0 & 0 & 0 & 0 & 0 & 1 & 0 & 0 & 0 & 1 & 1 & 1 \end{bmatrix} \quad (5)$$

224

225 The final inequality constraints of matrix A is formulated as follows:

226

$$f(x) = \begin{aligned} f_1 &= x_1 + x_2 + x_5 && \geq 1 && (6) \\ f_2 &= x_1 + x_2 + x_3 + x_4 + x_5 && \geq 1 && (7) \\ f_3 &= x_2 + x_3 + x_4 && \geq 1 && (8) \\ f_4 &= x_2 + x_3 + x_4 + x_5 + x_7 + x_9 && \geq 1 && (9) \\ f_5 &= x_1 + x_2 + x_4 + x_5 + x_6 && \geq 1 && (10) \\ f_6 &= x_5 + x_6 + x_{11} + x_{12} + x_{13} && \geq 1 && (11) \\ f_7 &= x_4 + x_7 + x_8 + x_9 && \geq 1 && (12) \\ f_8 &= x_7 + x_8 && \geq 1 && (13) \\ f_9 &= x_4 + x_7 + x_9 + x_{10} + x_{14} && \geq 1 && (14) \\ f_{10} &= x_9 + x_{10} + x_{11} && \geq 1 && (15) \\ f_{11} &= x_6 + x_{10} + x_{11} && \geq 1 && (16) \\ f_{12} &= x_6 + x_{12} + x_{13} && \geq 1 && (17) \\ f_{13} &= x_6 + x_{12} + x_{13} + x_{14} && \geq 1 && (18) \\ f_{14} &= x_9 + x_{13} + x_{14} && \geq 1 && (19) \end{aligned}$$

227

228 The above constraints imply that, for example, based on constraint (7), if a PMU is placed
 229 at bus 2, bus 1,2,3,4 and 5 are observable. The constraints (6)-(19) are then simulated using
 230 MATLAB and the result obtained from the simulation is:

$$[X] = [0 \ 1 \ 0 \ 0 \ 0 \ 0 \ 0 \ 1 \ 0 \ 1 \ 0 \ 0 \ 1 \ 0]^T \quad (20)$$

231
 232 Based on constraint (20), a PMU must be placed on bus 2, 8, 10, and 13 respectively in
 233 order to ensure the whole system is completely observable.
 234

235
 236 **b) Case II: Existence of ZIB for full network observability**

237 Based on Fig. 4, bus 7 is a ZIB and bus 8 is a radial bus. Since bus 8 is a radial bus, it is
 238 selected to be merged with the ZIB according to Rule A as mentioned in Section 4. This
 239 merging process means the constraint for bus 7 is removed from the equation and bus 8 is
 240 now connected directly to buses 4 and 9. Next, since this process involves a radial bus, a
 241 PMU must be pre-allocated to one of the buses that is incident to it.

242 However, since neither bus 4 nor bus 9 is a ZIB, a PMU is not pre-allocated to encourage
 243 more possible solutions. In the case where bus 4 is a ZIB, a PMU will be pre-allocated to bus
 244 9 to ensure that bus 8' is observable.

245 This topology transformation means the constraints for bus {4, 7, 8, 9} have changed. Note
 246 that the constraint for bus 7 is eliminated since it no longer exists after the topology
 247 transformation. Meanwhile, the constraints for bus {4, 8, 9} are updated to reflect the
 248 topology transformation made during the merging process.

249

$$f_4 = x_2 + x_3 + x_4 + x_5 + x_{8'} + x_9 \geq 1 \quad (21)$$

$$f_{8'} = x_4 + x_{8'} + x_9 \geq 1 \quad (22)$$

$$f_9 = x_4 + x_{8'} + x_9 + x_{10} + x_{14} \geq 1 \quad (23)$$

250

251 From these newly formed constraints, a total of three PMUs need to be placed at bus {2, 6, 9}
252 to ensure full observability of the network. Fig. 5 below shows the topology transformation
253 concerning ZIB before and after the merging process.

254

255 *c) Case III:* Existence of ZIB and power flow measurements for full network
256 observability

257

258 In this case, consider the power flow measurements exist on branch {1–5}, {6–11}, and
259 {9–10}. When considering the existence of power flow measurements and ZIB in OPP, it is
260 important that the power flow measurement is solved first followed by ZIB. If it is done
261 opposite to the proposed method, the result of the merging could imbalance the topology thus
262 leads an to infeasible solution. This is likely to happen in the situation where power flow is
263 existed next to two ZIBs. Hence, for one to apply this proposed method, when dealing with
264 power flow and ZIB, the power flow needs to be merged before ZIBs are merged.

265 As mentioned earlier in this paper, in the case of considering power flow measurements, if
266 one of the voltage buses is known, the value of the voltage at the other end can be computed.
267 Thus, the constraints that are related with the measured branch can be merged into a single
268 constraint. The new merged constraint makes certain that as long as the bus voltage at one
269 end of the branch is observable, the voltage at the opposite bus will also be observable. The
270 following are the final constraints involved after the merging process. Note that the
271 constraints for bus {5, 10, 11} are eliminated since they have merged with the opposite bus.
272 Notice also that the new constraint for bus 9 (26) is the consequence of Equations (14) and
273 (23).

$$f_1' = x_1 + x_2 + x_4 + x_5 + x_6 \geq 1 \quad (24)$$

$$f_6' = x_5 + x_6 + x_{10} + x_{11} + x_{12} + x_{13} \geq 1 \quad (25)$$

$$f_9' = x_4 + x_8' + x_9 + x_{10} + x_{11} + x_{14} \geq 1 \quad (26)$$

274

275 From constraints (24)-(26), it can be seen that for full system observability two PMUs are
 276 required to be placed at bus 4 and 13.

277 Table 1 summarizes the number of PMUs required for each case using the IEEE 14-bus
 278 system described in this section. Notice that the number of PMUs required decreases when
 279 considering power flow measurement and ZIB.

280

281 **Results and Discussion**

282 The flow of the ILP method is depicted in Fig. 6. All simulations results obtained based on
 283 the assumption that each PMU has the maximum number of channels and the cost of each
 284 PMU is the same. Notice that for Case I, the radial bus is not excluded from the candidates
 285 for PMU placement as illustrated in the program flowchart in Fig. 6.

286 Table 2 shows the locations of ZIB and radial bus in each IEEE bus system simulated in
 287 this paper. Meanwhile, Table 3 presents the locations of power flow measurement introduced
 288 for the IEEE 14, 57, and 118-bus systems. Table 4 shows the comparison for the number of
 289 PMUs required for Case I, II, and III for each IEEE bus systems using the proposed method.
 290 From Table IV, without considering conventional measurements the number of PMUs
 291 required for all bus systems tested is obviously higher than the number of PMUs required
 292 when considering conventional measurements. One can consider the number of PMUs
 293 required for the IEEE 118-bus system. Notice that 32 PMUs are required for complete
 294 observability when ignoring conventional measurement. The number of PMUs required is
 295 reduced to 28 PMUs when considering ZIB. This is possible because of ZIB presence allows

296 at least one bus to be calculated using pseudo-measurements by applying KCL at ZIB.
297 Hence, the number of PMUs required is expected to be reduced by at least one for each ZIB
298 available in the system depending on the location of the ZIB in each IEEE bus system. For
299 example, in the IEEE 14-bus system with the introduction of one ZIB, the number of PMUs
300 required is one less compared to the case when conventional measurement is ignored.
301 However, it is interesting to note that this is not always the case. For example, in the IEEE
302 24-bus system, the number of PMUs required is only one less even with the presence of four
303 ZIBs. However, one can conclude that the number of PMUs required are lower when ZIB is
304 considered in the power system.

305 Consider the comparison between Case I and Case III for the IEEE 118-bus system in
306 Table 4. It can be noted that the number of PMUs required is further reduced to 16, which is
307 half the number required for Case I, and lower than the Case II in which ZIB is considered,
308 which requires 28 PMUs. The existence of power flow measurement allows the voltage of the
309 incident bus to be calculated if the voltage for one of the buses involved is known. This
310 means it is enough to ensure one of the buses involved is observable by a PMU or pseudo-
311 measurement as long the voltage for one of the buses is known. When combined with ZIB,
312 the number of PMUs is expected to be further reduced since the method used is identical to
313 that used for the case of considering ZIB.

314 Table 5 shows the full locations of the PMUs for all cases for every bus system simulated.
315 As can be seen from the Table 5, PMUs are not placed at ZIB for the case of considering ZIB
316 and power flow measurements. The decision to remove the constraints for ZIB and power
317 flow measurements as the candidates for PMU placement has made this possible.

318 The simulation results for the case considering ZIB are compared with existing techniques
319 in Table 6. Based on the comparison results above, the number of PMUs required for the
320 proposed method is comparable and consistent across other methods used in existing

321 techniques. It should be noted that the ILP method can provide the minimum number of
322 PMUs required for the larger system.

323 The proposed method is specifically compared with the results obtained by Rather et al
324 [25] for New England 39-bus system and IEEE 57-bus system as shown in Table 7 below. As
325 can be noted from the table, measurement redundancy is larger when using the proposed
326 method for both bus system network despite having the same number of PMUs installed in
327 each bus system.

328

329 **Conclusion**

330 The simulation results confirm the method proposed in this paper can be used to solve the
331 OPP problem. The rules created to deal with ZIB managed to produce comparable result with
332 other existing methods. It also gives better measurement redundancy based on BOI and SORI
333 value which evaluate the quality of PMUs placements set. In addition, the PMU locations
334 given by this method is accurate unlike other merging technique. The proposed method also
335 shows that it can be incorporated with power flow measurement to find optimal PMU
336 placement. Furthermore, pre-assigned PMUs strategy help to reduce the total number of
337 possible candidates for PMU placement and hence allow consideration to be given to other
338 PMU placements in the power system. This paper will help the researchers as a platform to
339 understand how to deal with ZIB in order to achieve OPP in power system since the rules
340 developed are easy to implement and understand.

341

342 **References**

343 [1] Andersson G, Donalek P, Farmer R, Hatziargyriou N, Kamwa I, Kundur P, et al.
344 Causes of the 2003 Major Grid Blackouts in North America and Europe, and

- 345 Recommended Means to Improve System Dynamic Performance. IEEE Trans Power
346 Syst. 2005 Nov;20(4):1922–8.
- 347 [2] Xu Dongjie. Comparison of several PMU placement algorithms for state estimation.
348 Eighth IEE International Conference on Developments in Power System Protection.
349 IEE; 2004. p. 32–5.
- 350 [3] Morais H, Vancraeyveld P, Pedersen AHB, Lind M, Johannsson H, Ostergaard J.
351 SOSPO-SP: Secure Operation of Sustainable Power Systems Simulation Platform for
352 Real-Time System State Evaluation and Control. IEEE Trans Ind Informatics. 2014
353 Nov;10(4):2318–29.
- 354 [4] Wang Y, Wang C, Li W, Li J, Lin F. Reliability-Based Incremental PMU Placement.
355 IEEE Trans Power Syst. 2014 Nov;29(6):2744–52.
- 356 [5] Ghosh D, Ghose T, Mohanta DK. Communication Feasibility Analysis for Smart Grid
357 With Phasor Measurement Units. IEEE Trans Ind Informatics. 2013 Aug;9(3):1486–96.
- 358 [6] Gou B, Kavasseri RG. Unified PMU Placement for Observability and Bad Data
359 Detection in State Estimation. IEEE Trans Power Syst. 2014 Nov;29(6):2573–80.
- 360 [7] Huang L, Sun Y, Xu J, Gao W, Zhang J, Wu Z. Optimal PMU Placement Considering
361 Controlled Islanding of Power System. IEEE Trans Power Syst. 2014 Mar;29(2):742–
362 55.
- 363 [8] Mazhari SM, Monsef H, Lesani H, Fereidunian A. A Multi-Objective PMU Placement
364 Method Considering Measurement Redundancy and Observability Value Under
365 Contingencies. IEEE Trans Power Syst. 2013 Aug;28(3):2136–46.
- 366 [9] Sanchez-Ayala G, Aguerce JR, Elizondo D, Lelic M. Current trends on applications of
367 PMUs in distribution systems. 2013 IEEE PES Innovative Smart Grid Technologies
368 Conference (ISGT). IEEE; 2013. p. 1–6.

- 369 [10] Bottura R, Borghetti A. Simulation of the Volt/Var Control in Distribution Feeders by
370 Means of a Networked Multiagent System. IEEE Trans Ind Informatics. 2014
371 Nov;10(4):2340–53.
- 372 [11] Nuqui RF, Phadke AG. Phasor Measurement Unit Placement Techniques for Complete
373 and Incomplete Observability. IEEE Trans Power Deliv. 2005 Oct;20(4):2381–8.
- 374 [12] Mili L, Baldwin T, Adapa R. Phasor measurement placement for voltage stability
375 analysis of power systems. 29th IEEE Conference on Decision and Control. IEEE;
376 1990. p. 3033–8 vol.6.
- 377 [13] Bei Xu, Abur A. Observability analysis and measurement placement for systems with
378 PMUs. IEEE PES Power Systems Conference and Exposition, 2004. IEEE; 2004. p.
379 1472–5.
- 380 [14] Bei X, Yoon YJ, Abur A. Optimal Placement and Utilization of Phasor Measurements
381 for State Estimation. Final Proj Report, PSERC. 2005;1–6.
- 382 [15] Gou B. Optimal Placement of PMUs by Integer Linear Programming. IEEE Trans
383 Power Syst. 2008 Aug;23(3):1525–6.
- 384 [16] Gou B. Generalized Integer Linear Programming Formulation for Optimal PMU
385 Placement. IEEE Trans Power Syst. 2008 Aug;23(3):1099–104.
- 386 [17] Dua D, Dambhare S, Gajbhiye RK, Soman SA. Optimal Multistage Scheduling of
387 PMU Placement: An ILP Approach. IEEE Trans Power Deliv. 2008 Oct;23(4):1812–
388 20.
- 389 [18] Abbasy NH, Ismail HM. A Unified Approach for the Optimal PMU Location for Power
390 System State Estimation. IEEE Trans Power Syst. 2009 May;24(2):806–13.
- 391 [19] Enshaee A, Hooshmand RA, Fesharaki FH. A new method for optimal placement of
392 phasor measurement units to maintain full network observability under various
393 contingencies. Electr Power Syst Res. 2012 Aug [cited 2015 Mar 15];89:1–10.

- 394 [20] Mohammadi-Ivatloo B, Hosseini SH. Optimal PMU placement for power system
395 observability considering secondary voltage control. 2008 Canadian Conference on
396 Electrical and Computer Engineering. IEEE; 2008. p. 000365–8.
- 397 [21] Al-Mohammed AH, Abido MA, Mansour MM. Optimal placement of synchronized
398 phasor measurement units based on differential evolution algorithm. 2011 IEEE PES
399 Conference on Innovative Smart Grid Technologies - Middle East. IEEE; 2011. p. 1–9.
- 400 [22] Chakrabarti S, Kyriakides E. Optimal Placement of Phasor Measurement Units for
401 Power System Observability. IEEE Trans Power Syst. 2008 Aug;23(3):1433–40.
- 402 [23] Aghaei J, Baharvandi A, Rabiee A, Akbari MA. Probabilistic PMU Placement in
403 Electric Power Networks: An MILP-Based Multi-objective Model. IEEE Trans Ind
404 Informatics. 2015;11(2):1–1.
- 405 [24] Ahmadi A, Alinejad-beromi Y, Moradi M. Optimal PMU placement for power system
406 observability using binary particle swarm optimization and considering measurement
407 redundancy. Expert Syst Appl. 2011;38(6):7263–9.
- 408 [25] Rather ZH, Liu C, Chen Z, Thogersen P. Optimal PMU Placement by improved
409 particle swarm optimization. 2013 IEEE Innovative Smart Grid Technologies-Asia
410 (ISGT Asia). IEEE; 2013. p. 1–6.
- 411 [26] Havangi R, Taghirad HD, Nekoui MA, Teshnehlab M. A Square Root Unscented
412 FastSLAM With Improved Proposal Distribution and Resampling. IEEE Trans Ind
413 Electron. 2014 May;61(5):2334–45.
- 414 [27] Su C, Chen Z. Optimal Placement of Phasor Measurement Units with New
415 Considerations. 2010 Asia-Pacific Power and Energy Engineering Conference. IEEE;
416 2010. p. 1–4.

- 417 [28] Saha Roy BK, Sinha AK, Pradhan AK. An optimal PMU placement technique for
418 power system observability. *Int J Electr Power Energy Syst.* 2012 Nov [cited 2015 Mar
419 16];42(1):71–7.
- 420 [29] Aminifar F, Khodaei A, Fotuhi-Firuzabad M, Shahidehpour M. Contingency-
421 Constrained PMU Placement in Power Networks. *IEEE Trans Power Syst.* 2010
422 Feb;25(1):516–23.
- 423 [30] Esmaili M. Inclusive multi-objective PMU placement in power systems considering
424 conventional measurements and contingencies. *Int Trans Electr Energy Syst.* 2016
425 March;26(3):609-626.
- 426 [31] Meier A. Power Flow Analysis. *Electric Power Systems.* Hoboken, NJ, USA: John
427 Wiley & Sons, Inc.; 2006. p. 195–228.

428 Table 1 Number of PMUs required for each case for IEEE 14-bus system.

Bus System Network	Number of PMUs		
	Case I (Ignoring conventional measurement)	Case II (ZIB)	Case III (ZIB and power flow measurements)
IEEE 14	4	3	2
PMU location	2, 8, 10, 13	2, 6, 9	4, 13

429

430 Table 2 Location of ZIB and radial bus

Bus system network	Location of ZIB	Location of radial bus
IEEE 14	7	8
IEEE 24	11, 12, 17, 24	7
IEEE 30	6, 9, 22, 25, 27, 28	11, 13, 26
NE-39	1, 2, 5, 6, 9, 10, 11, 13, 14, 17, 19, 22	30, 31, 32, 33, 34, 35, 36, 37, 38
IEEE 57	4, 7, 11, 21, 22, 24, 26, 34, 36, 37, 39, 40, 45, 46, 48	33
IEEE 118	5, 9, 30, 37, 38, 63, 64, 68, 71, 81	10, 73, 87, 111, 112, 116, 117

431

432 Table 3 Location of power flow measurements

Bus System	Number of power flow locations	Flow location
IEEE 14	3	1-5, 6-11, 9-10
IEEE 57	14	14-15, 15-45, 18-19, 21-22, 22-38, 24-26, 28-29, 30-31, 34-35, 36-40, 39-57, 47-48, 50-51, 53-54
IEEE 118	32	1-3, 5-6, 11-13, 16-17, 20-21, 22-23, 23-25, 27-28, 29-31, 34-43, 35-36, 41-42, 44-45, 46-48, 50-57, 51-52, 53-54, 56-58, 60-62, 65-66, 66-67, 68-81, 71-73, 75-118, 76-77, 77-82, 78-79, 86-87, 90-91, 95-96, 100-101, 114-115

433

434

435 Table 4 The number of PMUs required for case I, II and III

Bus System Network	Number of PMUs		
	Case I (Ignoring conventional measurement)	Case II (ZIB)	Case III (ZIB and power flow measurements)
IEEE 14	4	3	2
IEEE 24	7	6	N/A
IEEE 30	10	7	N/A
NE 39	13	8	N/A
IEEE 57	17	11	10
IEEE 118	32	28	16

436

437

438 Table 5 Location of PMUs for case I, II and III

Bus System Network	PMU location		
	Case I (Ignoring conventional measurement)	Case II (ZIB)	Case III (Power flow measurements)
IEEE 14	2, 8, 10, 13	2, 6, 9	4,13
IEEE 24	2, 3, 7, 10, 16, 21, 23	1, 2, 8, 16, 18, 23	N/A
IEEE 30	1, 7, 8, 10, 11, 12, 19, 23, 26, 30	1, 7, 10, 12, 19, 24, 30	N/A
NE-39	2, 6, 9, 12, 14, 17, 22, 23, 29, 32, 33, 34, 37	3, 8, 12, 16, 20, 23, 25, 29	N/A
IEEE 57	2, 6, 12, 15, 19, 22, 25, 27, 32, 36, 38, 41, 46, 50, 52, 55, 57	1, 6, 13, 19, 25, 29, 32, 38, 51, 54, 56	1, 3, 6, 9, 25, 32, 38, 41, 51, 53
IEEE 118	2, 5, 10, 12, 15, 17, 21, 25, 29, 34, 37, 41, 45, 49, 53, 56, 62, 64, 72, 73, 75, 77, 80, 85, 87, 91, 94, 101, 105, 110, 114, 116	3, 8, 11, 12, 17, 21, 25, 29, 33, 34, 40, 45, 49, 53, 56, 62, 72, 75, 77, 80, 85, 86, 91, 94, 102, 105, 110, 114	8, 11, 12, 19, 32, 33, 40, 49, 59, 72, 74, 80, 85, 92, 105, 110

439

440

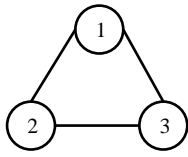

(a)

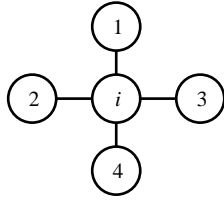

(b)

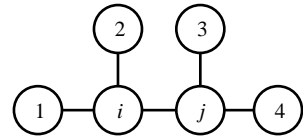

(c)

448 Fig. 1 Modeling PMU placement rules

449

450

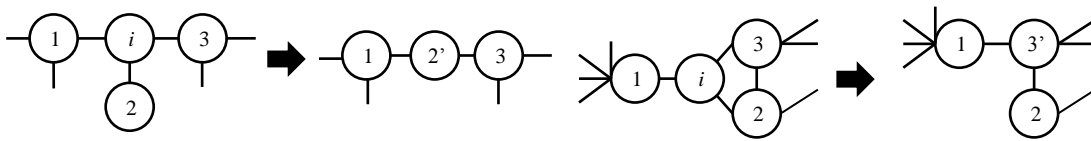

(a)

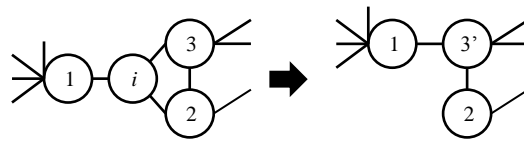

(b)

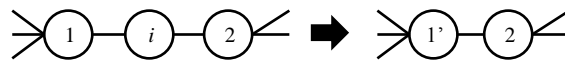

(c)

451 Fig. 2 Modeling merging process

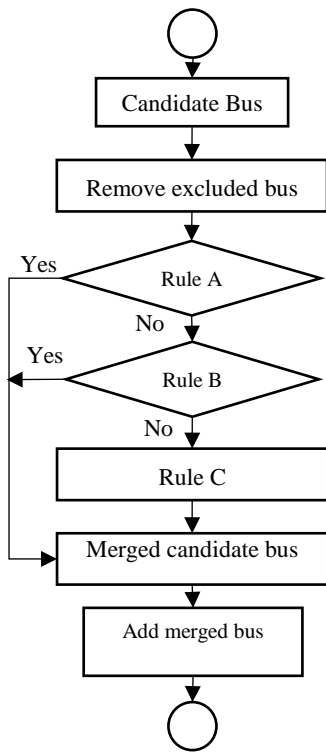

452

453 Fig. 3 Flowchart for rules evaluation for candidate bus

454

455

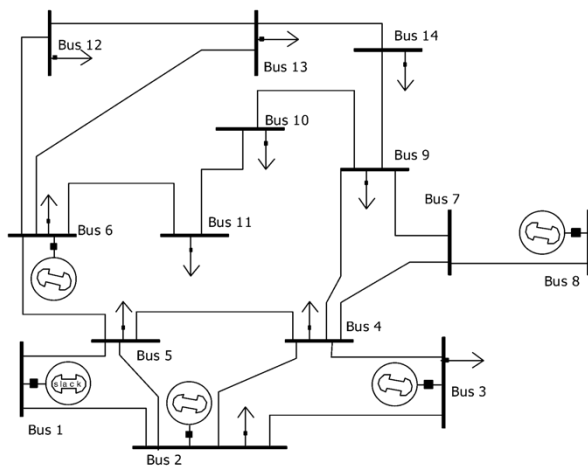

456

457 Fig. 4 IEEE 14-bus system. In this bus system, bus 7 is a ZIB and bus 8 is a radial bus [22]

458

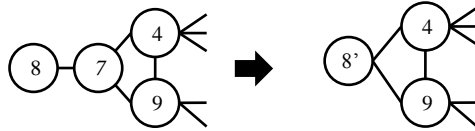

459

460 Fig. 5 Modeling ZIB for IEEE 14-bus system before (left) and after (right).

461

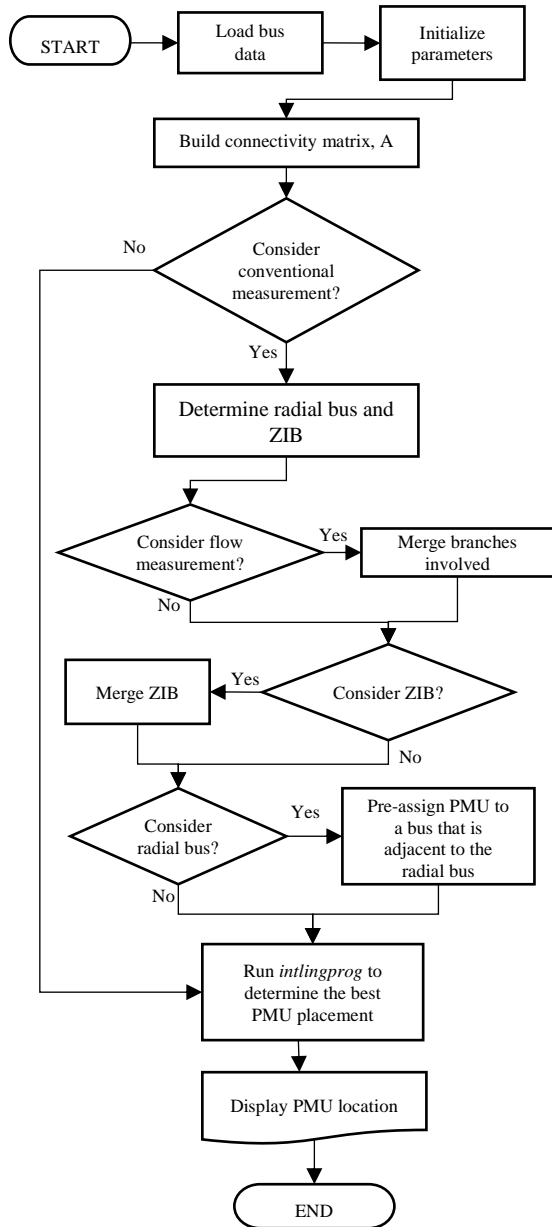

462

463 Fig. 6 Flowchart of the implemented MATLAB program

464