

# **Optimal C-type Filter for Harmonics Mitigation and Resonance Damping in Industrial Distribution Systems**

Shady H. E. Abdel Aleem<sup>1</sup>, Ahmed F. Zobaa<sup>2</sup>

<sup>1</sup>15<sup>th</sup> of May Higher Institute of Engineering, Mathematical, Physical, and Engineering Sciences, Helwan, Cairo, Egypt (email: [engyshady@ieee.org](mailto:engyshady@ieee.org))

<sup>2</sup>College of Engineering, Design & Physical Sciences, Brunel University London, Uxbridge, Middlesex, UB8 3PH, United Kingdom (email: [azobaa@ieee.org](mailto:azobaa@ieee.org))

\*Corresponding author: Tel.: +201227567489. Fax: +2025519101. E-mail: [engyshady@ieee.org](mailto:engyshady@ieee.org)

# Optimal C-type Filter for Harmonics Mitigation and Resonance Damping in Industrial Distribution Systems

**Abstract:** Single-tuned passive filters offer reasonable mitigation for harmonic distortion at a specific harmonic frequency with a high filtering percentage, but resonance hazards exist. Traditional damped filters offer high-pass filtering for the high-frequency range, but suffer from extra ohmic losses. C-type filters may operate in a manner similar to the tuned filters with low damping losses and marginal resonance damping capabilities. Also, they can be designed as damped filters with increased resonance damping capability. In this paper, a methodology that facilitates sizing for the C-type damped filter parameters for harmonics mitigation and resonance damping in balanced distribution system networks, is presented and discussed using the impedance-frequency index. This index evaluates the resonance damping capability provided by the damped filters analytically rather than the conventional graphical method of impedance-frequency scanning. It shows how to size shunt passive filters, while making a full use of their damping capabilities. It can disclose the parallel resonance frequencies of the equivalent system-filter impedance. A comparative study of the new approach and a conventional filter design approach, which aims to minimize total harmonic current distortion, is presented. Numerous simulation results are provided to clarify the proposed methodology, advantages, and disadvantages.

**Keywords:** Damped filters, harmonic distortion, optimization, reactive power compensation, resonance.

## 1. Introduction

Power system harmonics, an important topic within the quality of power domain, have been an area of discussion for decades. Several solutions for mitigating harmonic distortion in power systems have been practiced. Often when the subjects of power system harmonic suppression and reactive-power compensation arise and the economical aspects are taken into account, most industrial firms routinely suppose the use of passive facilities. In general, passive filters are not the best kind. They can cause resonance with source impedance. Also, they are not adaptable to the variations in power system networks. However, they are widely used and represent the primary interest of most users, especially for the existing industrial firms for controlling harmonics and correction of power factors, because of their simplicity, low cost, and easy configuration and maintenance [1–4].

Passive filters can be classified into two broad categories: (a) tuned and (b) high-pass filters. There are two main kinds of tuned filters as single-tuned and double-tuned filters [2, 5]. A single-tuned (notch) filter has high attenuation for harmonic orders close to its pre-determined tuning frequency. But, it can lead to resonance problems in the system [6]. Since a double-tuned filter behaves like two single-tuned filters in parallel with each other [7], it inherits the same resonance problem, as the single-tuned notch filter. Typically, high-pass passive filters are divided into first order, second order and third order high-pass filters. Traditional high-pass filter topologies guarantee high-pass filtering for the high-frequency range (basically, the 11th and 13th harmonics, and higher), but suffer from extra ohmic losses. Thus, they cannot be economically used at low order harmonics (the 5th and 7th harmonics, and lower). However, third order C-type damped filters may be applicable in such cases. A C-type passive filter (CTPF) is an alternative approach belonging to the high-pass filters family [5]. It can attenuate a broad range of harmonic frequencies generated by nonlinear loads [7]. It has two distinct advantages compared to tuned and high-pass damped filters. The first is the reduced fundamental frequency loss compared to other configurations of damped filters, and the second is its capability to dampen harmonic resonance that may occur, compared to the tuned filters. Ref. [8] introduced an optimal design of the CTPF on the basis of minimization of the total harmonic voltage distortion (THDV), [9] used it for maximization of load power factor (PF), [10] used it to maximize transformer's loading capability under non-sinusoidal conditions. However, the introduced filters were working in a manner nearly identical to the most traditional series-tuned filters, without considering the additional resonance damping merits gained by the C-type facility. The sizing of the parameters of the

CTPF determines how it operates. The CTPF can act in a manner nearly identical to the single-tuned filter, the second-order high-pass filter, or a resonance damper filter with adequate harmonics attenuation capability.

In this paper, an optimal sizing of the  $C$  damped filter parameters is introduced. The proposed design quantifies its resonance damping capability analytically rather than the conventional graphical method of impedance-frequency scanning. For this aim, minimization of the frequency response index, which is earlier defined in [5] to evaluate the performance of several passive filter combinations, is chosen as the objective of the proposed design. The proposed design decreases the chances of series and parallel resonance over a broad range of harmonic frequencies, avoids overloading of the passive filter, attenuates the harmonic distortion of the load voltage and the line current waveforms according to the limitations defined in IEEE Standard 519. Additionally, it decreases the effect of variations in system impedance (unlike single-tuned filters), which represents a particular concern in power system networks using passive filters [6].

A comparative study of the proposed design and a conventional optimal filter design approach, which aims to minimize total harmonic current distortion (THDI), is presented using two study cases. It should be mentioned that minimizing THDI is just an example of many conventional filter design approaches that exist in the literature, such as maximization of PF, minimization of THDV, filter loss, and investment cost [10]. Furthermore, a comparative study of the damped CTPF and single-tuned passive filter (STPF) designs is presented and discussed to highlight the advantages and disadvantages of the proposed methodology.

By definition, a STPF is not a damped filter, it can offer low impedance only the tuned frequency. However, it is one of the most economical types of passive filters that has a low filter loss, and is frequently used to provide power factor correction in addition to harmonic mitigation in distribution systems and industrial applications. The Fortran Feasible Sequential Quadratic Programming (FFSQP) algorithm has been employed for the optimal design of the proposed filters. It depends on the approach of sequential approximation in reinstating the given nonlinear problem with a set of subproblems that are easier to solve. Additionally, depending on the degree of compactness and appropriate selection of the constraints, trade-offs between design alternatives will be expressively examined, and the optimization process may be stopped after a few iterations, yielding a feasible point. Hence, after determination of all feasible local points, the localized global solution will be selected. Finally, the most important advantage of this algorithm is a reduction in the amount of computation required in order to generate a new iterate with high computational speed [19]. Exact formulations of the search algorithm of the FFSQP package are found in [11]. Furthermore, FFSQP has been used for damped and single-tuned shunt passive filter designs in [8, 12], respectively.

## 2. Theory of Operation of the C-type Passive Filters

**Fig. 1(a)** demonstrates the equivalent circuit of the CTPF. Based on [7–10], the main feature of this type of filter which distinguishes it from the second-order high-pass filter is its auxiliary capacitive reactance  $X_{C2}$  in series with the inductive reactance  $X_L$ . They resonate at the fundamental frequency,  $X_L=X_{C2}=X$ , bypassing the damping resistor  $R_d$  by the series-tuned branch, which makes the filter equivalent to a capacitive reactance  $X_{C1}$  connected in parallel to the load, as shown in **Fig. 1(b)**, this is why it is commonly called a CTPF, hence, the fundamental power loss of the filter is minimized (theoretically neglected), allowing a CTPF to be tuned to a low frequency, this is the main difference between a CTPF and a second order high-pass filter. The capacitive reactance  $X_{C1}$  is calculated from the values of reactive power  $Q_C$  needed for power factor correction and harmonic filtering, and the load nominal voltage  $V_L$  [8, 10]. The  $n$ th harmonic impedance of the CTPF ( $Z_{Cn}$ ), where  $n$  represents the harmonic number, is given as

$$Z_{Cn} = \frac{jR_d \left( nX_L - \frac{X_{C2}}{n} \right)}{R_d + j \left( nX_L - \frac{X_{C2}}{n} \right)} - j \frac{X_{C1}}{n} = R_{Fn} + jX_{Fn} \quad (1)$$

where

$$R_{Fn} = \frac{R_d \left( X \left( n - \frac{1}{n} \right) \right)^2}{R_d^2 + \left( X \left( n - \frac{1}{n} \right) \right)^2} \quad (2)$$

$$X_{Fn} = \frac{R_d^2 \left( X \left( n - \frac{1}{n} \right) \right)}{R_d^2 + \left( X \left( n - \frac{1}{n} \right) \right)^2} - \frac{X_{C1}}{n} \quad (3)$$

$$X_{C1} = \frac{V_L^2}{Q_C} \quad (4)$$

As frequency increases, the CTPF possesses a similar response to the second-order high-pass filter because of the low value of its auxiliary capacitive reactance  $X_{C2}$  and the high value of the inductive reactance  $X_L$ , as shown in **Fig. 1(c)**. Consequentially, the inductive reactance of the filter resonates with its capacitive one. In such a case, the CTPF is replaced by a resistance,  $R_F$ , as shown in **Fig. 1(d)**. In other words, the  $n$ th reactance  $X_{Fn}$  of the filter at  $h$  equals zero, where  $h$  is the filter resonant-harmonic number,  $X_{Fn}=0$ . The value of  $R_F$  is considered by determination of the maximum harmonic current ( $\rho_S$ ) that is allowed to flow through the supply reactance  $X_S$  at  $h$  and is a complex quantity [8]. According to [2], conventional shunt passive filters may have a typical  $\rho_S$  value of 0.005 with an angle close to  $-2.6^\circ$ . Accordingly, [8] defined  $R_F$  as follows:

$$R_F = \frac{hX_S}{\sqrt{\left( \frac{1}{|\rho_S(h)|} \right)^2 - 1}} \quad (5)$$

At high frequencies, the inductive reactance increases rapidly and most of the filter current will pass through the resistive branch, which makes the filter behave as a first-order filter, as shown in **Fig. 1(e)**.

Following the previous conditions, the CTPF parameters,  $R_d$  and  $X$  can be given as follows [9]:

$$R_d = \frac{X_{C1}^2 + (hR_F)^2}{h^2 R_F} \quad (6)$$

$$X = \frac{X_{C1}^2 + (hR_F)^2}{X_{C1} (h^2 - 1)} \quad (7)$$

Also, the filtering percentage (FP) is defined as follows [13]:

$$FP = 100 * (1 - \rho_S) \quad (8)$$

A low  $\rho_S$  means a high filtering percentage, if  $\rho_S$  is set as low as possible, the amount of harmonic current flowing into the filter will increase, due to the small  $R_f$ , but the filter will have less damping compared to others with higher values of  $\rho_S$ , because the damping resistor  $R_d$  will have a large value. Roughly speaking, the most advantageous filtering performance increases the filter resistance  $R_d$  in order to guarantee that a higher possible part of the eliminated harmonic current will flow through the filter. Paradoxically, low values of  $R_d$  will increase the filter's ability to dampen resonance. Thus, the optimal value of  $R_d$  should be a compromise between the resonance damping needed and the required  $FP$  [14]. This leads [15] to define  $R_d$  directly as a function of the main capacitive reactance  $X_{Cl}$  and the filter resonant-harmonic number  $h$ , as follows:

$$R_d = m \frac{X_{Cl}}{h} \quad (9)$$

where  $m$  is a factor that determines the filter parallel damping resistance. Ref. [15] recommends that values of  $m$  should be less than 20 to achieve the highest performance of CTPFs.

### 3. The Concept of the Impedance-Frequency Index

**Fig. 2** shows the Thevenin equivalent circuit of a power system at the filter location and the CTPF to be installed. The source harmonic currents and voltages are given as  $\bar{I}_{S_n}$  and  $\bar{V}_{S_n}$  respectively, while the load harmonic currents and voltages at the point of common coupling (PCC) are given as  $\bar{I}_{L_n}$  and  $\bar{V}_{L_n}$  respectively, as shown in the single-phase equivalent circuit of the system. The nonlinear load on the load side is simplified as a current source.  $\bar{Z}_{S_n}$  ( $R_{S_n} + jX_{S_n}$ ),  $\bar{Z}_{F_n}$  ( $R_{F_n} + jX_{F_n}$ ), and  $\bar{Z}_{L_n}$  ( $R_{Load,n} + jX_{Load,n}$ ) are the  $n$ th Thevenin, filter, and load impedances, respectively. The  $n$ th harmonic main current  $\bar{I}_{S_n}$  and load voltage  $\bar{V}_{L_n}$  are given respectively as;

$$\bar{I}_{S_n} = \frac{\bar{V}_{S_n} (\bar{Z}_{F_n} + \bar{Z}_{L_n}) + \bar{I}_{L_n} (\bar{Z}_{F_n} \bar{Z}_{L_n})}{\bar{Z}_{S_n} \bar{Z}_{F_n} + \bar{Z}_{S_n} \bar{Z}_{L_n} + \bar{Z}_{F_n} \bar{Z}_{L_n}} \quad (10)$$

$$\bar{V}_{L_n} = \bar{V}_{S_n} - \bar{I}_{S_n} (\bar{Z}_{S_n}) \quad (11)$$

It should be noted that a dash above a respective variable denotes a complex value. Hence, the rms values of the load voltage ( $V_L$ ), the supply current ( $I_S$ ), and the expressions of  $THD_V$  and  $THD_I$  measured at the PCC, can be calculated. The true power factor (PF) measured at the PCC is given as

$$PF = \frac{P}{S} = \frac{\sum_n V_{L_n} I_{S_n} \cos \varphi_n}{V_L I_S} \quad (12)$$

The transmission power loss (TL) is given as shown in (13), where  $R_{S_n}$  is given as a function of the harmonic number and the fundamental value of the  $R_{S1}$ .

$$TL = \sum_n I_{S_n}^2 R_{S_n} \quad (13)$$

The equivalent impedance  $\bar{Z}_n$  from the viewpoint of the harmonic current-source on the load side is given as

$$\bar{Z}_n = \frac{\bar{Z}_{Sn} \bar{Z}_{Fn} \bar{Z}_{Ln}}{\bar{Z}_{Sn} \bar{Z}_{Fn} + \bar{Z}_{Sn} \bar{Z}_{Ln} + \bar{Z}_{Fn} \bar{Z}_{Ln}} \quad (14)$$

The harmonic current feedback to the utility-side (assuming an ideal voltage source) is given as

$$\frac{\bar{I}_{Sn}}{\bar{I}_{Ln}} = \frac{\bar{Z}_n}{\bar{Z}_{Sn}} \quad (15)$$

As parallel resonance occurs,  $|\bar{Z}_n|$  will be amplified. Hence, the harmonic current feedback to the utility-side will increase as implied in (15). Damping of parallel resonance means that  $|\bar{Z}_n|$  will get lower. Accordingly, the resonance damping capability of the CTPF, or any damped filter, can be presented using the impedance-frequency response index (FS) as follows:

$$FS = \sum_{n=1} |Z_n| \quad (16)$$

$FS$  is calculated from the system frequency-response with the filter installed. It is found by summing and grouping values of the impedance-frequency scan at the  $n$ th harmonics, as shown in (16). Ref. [5] demonstrates that the impedance magnitudes may be weighted by a factor of  $(1/n)$  for several filters combinations as the injected harmonic currents typically have a  $(1/n)$  magnitude relationship. Referring to **Fig. 2**, the total harmonic equivalent impedance  $\bar{Z}_{Tn}$  seen from the source-side is a combination of the system Thevenin impedance  $\bar{Z}_{Sn}$  and the resultant parallel impedance of filter and load  $(\bar{Z}_{Fn} \parallel \bar{Z}_{Ln})$ , as follows:

$$\bar{Z}_{Tn} = \bar{Z}_{Sn} + \frac{\bar{Z}_{Fn} \bar{Z}_{Ln}}{\bar{Z}_{Fn} + \bar{Z}_{Ln}} \quad (17)$$

Considering the load resistance and reactance large enough [16]; (17) can be simplified as follows:

$$\bar{Z}_{Tn} = (R_{Sn} + R_{Fn}) + j(X_{Sn} + X_{Fn}) \quad (18)$$

When series resonance occurs,  $|\bar{Z}_{Tn}|$  will equal  $(R_{Sn} + R_{Fn})$ . This means that the combined system-filter resistance may present sufficient damping for series resonance and reduce the associated harmonic current for high values of  $R_{Fn}$ . Generally speaking, a high value of  $FS$  indicates that the filter has little damping capability. It may be an indication that we need to find an alternative approach, such as using active and/or hybrid filters. On the contrary, a low value of  $FS$  implies that  $R_d$  is small, and thus a high value of  $R_F$  is expected, providing adequate damping for both series and parallel resonances. Thus, this index can be used to quantify the capability of damping the resonance of the damped passive filters.

#### 4. Formulation of the Optimization Problems

Minimization of the  $THD_I$ , measured at the PCC, is selected to represent the conventional approach for the optimal sizing of the CTPF. On the other hand, minimization of the  $FS$  is used to represent the proposed approach for the sizing of the CTPF parameters as a damped filter with enhanced resonance damping capability. Both of them are formulated as functions of the filter parameters. Hence, the nonlinear problem formulations of the design approaches are demonstrated, respectively as follows.

$$\text{Min}_{X_{C1}, X, R_d} \text{THD}_I = f(X_{C1}, X, R_d) \quad (19)$$

$$\text{Min}_{X_{C1}, X, R_d} \text{FS} = f(X_{C1}, X, R_d) \quad (20)$$

Both the conventional and proposed objective functions given in (19) and (20) are subjected to the following constraints:

$$90\% \leq \text{PF}(X_{C1}, X, R_d) < 100\% \quad (21)$$

$$\text{THD}_V(X_{C1}, X, R_d) \leq \text{THD}_V^{\max} \quad (22)$$

$$\text{IHD}_V(X_{C1}, X, R_d) \leq \text{IHD}_V^{\max} \quad (23)$$

$$\text{THD}_I(X_{C1}, X, R_d) \leq \text{THD}_I^{\max} \quad (24)$$

$$\text{IHD}_I(X_{C1}, X, R_d) \leq \text{IHD}_I^{\max, n} \quad (25)$$

where  $\text{THD}_V^{\max}$  is the maximum permissible THD limit for the considered voltage level.  $\text{IHD}_V^{\max}$  is the maximum permissible individual harmonic voltage distortion limit. They are considered to be equal 5% and 3%, respectively, as defined in IEEE 519-2014 for a voltage level less than 69 kV [13].  $\text{THD}_I^{\max}$  is the maximum permissible current THD limit, and  $\text{IHD}_I^{\max, n}$  is the maximum permissible individual harmonic current distortion limit. It depends on the short-circuit strength of the system under study as well as the harmonic number [13]. Besides, for both approaches, compliance of the main capacitor with the shunt power capacitor duties defined in IEEE Standard 18-2012 [17], is taken into account. Readers may refer to [8, 12] for the formulation of the search algorithms using FFSQP.

## 5. Cases Under Study and their Simulated Results

Two cases of a balanced industrial distribution system are considered to examine the results of the proposed and conventional design approaches. This typical system is originally taken from [13]. Both system cases (Cases 1 and 2) have: short circuit power capacity as 80 and 150 MVA, respectively. The 60 Hz line–line supply voltage is 4.16 kV. For cases 1 and 2, the system's Thevenin source impedance ( $Z_{S1}$ ) are  $0.02163 + j0.2163$  and  $0.01154 + j0.1154$ , respectively. The consumer sides of the considered system cases have a group of induction motors, other different loads, and thyristor DC drive loads. For the cases without compensation, the three-phase fundamental harmonic active and three-phase fundamental harmonic reactive powers measured at the PCC are 5.1 MW and 4.965 Mvar. The short-circuit ratio (SCR) of the system under study is given as 11.24 and 21.07 for cases 1 and 2, respectively.

In both cases, the  $d\text{PF}$  measured at the same load bus is 71.6527% lagging. For the single-phase equivalent of the exemplary system given in Fig. 2, harmonic components of the voltage and current sources are given in **Table 1**. For the uncompensated system,  $\text{PF}$ ,  $\text{THD}_V$ ,  $\text{THD}_I$ , and  $\text{TL}$  (per-phase) are 71.27, 7.522, 5.776, and 56.13 kW for Case 1 and 71.38, 5.01, 5.91, and 31.90 kW for Case 2, respectively. The compensated system simulation results are given in **Table 2**.

**Table 3** shows the optimal size of the proposed filters' parameters, specifications, main capacitors' loading duties, filtering percentages, and the impedance–frequency response indices.

**Table 4** shows the performance of the STPF, for the two presented approaches under the same conditions in order to show the effectiveness of the proposed CTPF in harmonic mitigation and resonance dampen compared to the system using STPF. Although STPF is not a damped filter, its internal resistance added to an optional external resistance in series with the

inductor may provide marginal resonance damping and reduce the harmonic current [18].

**Table 1** Harmonic components of the supply voltage and the load current

$n$	$\bar{V}_{s_n}$ (V)	$\bar{I}_{L_n}$ (A)
5	50.00 $\angle 0^\circ$	37.50 $\angle -5 \cdot 45^\circ$
7	30.00 $\angle 0^\circ$	32.50 $\angle -7 \cdot 45^\circ$
11	25.00 $\angle 0^\circ$	27.50 $\angle -11 \cdot 45^\circ$
13	20.00 $\angle 0^\circ$	20.00 $\angle -13 \cdot 45^\circ$
17, 19, 23, 25	15.00 $\angle 0^\circ$	7.50 $\angle -n \cdot 45^\circ$
29, 31, 35, 37	10.00 $\angle 0^\circ$	5.00 $\angle -n \cdot 45^\circ$
41, 43, 47, 49	5.00 $\angle 0^\circ$	3.75 $\angle -n \cdot 45^\circ$

**Table 2** The system results after compensation for the CTPF

Approach	Conventional		Proposed	
	Case 1	Case 2	Case 1	Case 2
Parameters				
$PF$ (%)	95.00	94.99	99.48	99.76
$dPF$ (%)	95.20	95.18	99.56	99.96
$I_s$ (A)	724.22	734.63	710.90	709.02
$V_L$ (V)	2339.76	2370.87	2399.73	2398.52
$TL$ (kW)	34.27	18.84	33.02	17.63
$THD_I$ (%)	4.37	5.25	4.99	7.98
$THD_V$ (%)	4.51	3.66	2.87	3.15

**Table 3** The CTPF specifications for both approaches

Approach	Conventional		Proposed	
	Case 1	Case 2	Case 1	Case 2
Parameters				
$X_{Cl}$ ( $\Omega$ )	5.203	5.211	3.179	3.39
$X$ ( $\Omega$ )	0.427	0.473	0.294	0.347
$R_d$ ( $\Omega$ )	14.02	6.146	1.55	1.322
Filter losses (kW)	1.26	2.13	4.68	5.99
$m$	9.83	4.21	2.07	2.09
$h$	3.65	3.56	4.25	5.37
$FP$ (%)	81.78	33.27	47.46	18.98
$FS$ ( $\Omega$ )	154.75	96.95	59.74	49.14
	Main capacitor duties with respect to nominal values			
$V_C$ (%)	97.41	98.74	99.96	99.91
$V_{C, peak}$ (%)	100.13	101.34	102.76	103.16
$I_C$ (%)	97.88	99.17	100.41	100.54
$Q_C$ (%)	95.34	97.91	100.37	100.45



**Table 4** The system results after compensation for the STPF

Approach	Conventional		Proposed	
Parameters	Case 1	Case 2	Case 1	Case 2
$X_C$ ( $\Omega$ )	5.66	5.696	3.435	5.512
$X_L$ ( $\Omega$ )	0.442	0.484	0.221	0.320
$R$ ( $\Omega$ )	0.079	0.083	0.044	0.061
$PF$ (%)	94.99	94.99	99.48	95.02
$dPF$ (%)	95.23	95.26	99.67	95.31
$I_S$ (A)	730.99	741.68	719.69	739.88
$V_L$ (V)	2339.45	2370.85	2397.93	2370.91
$TL$ (kW)	34.92	19.22	33.84	19.15
$THD_I$ (%)	4.53	5.59	4.91	6.62
$THD_V$ (%)	4.71	3.79	3.34	3.21
$Filter\ losses$ (kW)	15.96	17.26	24.64	12.96
$FP$ (%)	94.86	79.52	94.85	87.39
$FS$ ( $\Omega$ )	164.90	108.52	125.87	98.32
Main capacitor duties with respect to nominal values				
$V_C$ (%)	105.62	107.88	106.72	104.84
$V_{C, peak}$ (%)	108.41	110.31	109.25	108.72
$I_C$ (%)	106.08	108.25	107.10	105.88
$Q_C$ (%)	112.05	116.78	114.31	111.01

The power quality indices after compensation and the filter specification, which are obtained for the system with lower (Case 1) and higher (Case 2) short-circuit capacity with the same harmonic distortion levels, are given in **Table 2**, **Table 3** and **Table 4**, respectively. It is seen from **Table 2** and **Table 4** that the total distortion values of the harmonic currents, which flow through the supply side, have lower magnitudes for Case 1 when compared to Case 2 because of the higher Thevenin impedance, which attenuate the current source harmonics. Thus, it is noted from **Table 3** that the filters designed according to both approaches for Case 1 have higher  $R_d$  and lower  $X$  values, which results in higher filtering capability (or higher  $FP$ ), lower resonance damping capability (or higher  $FS$ ) and lower filter losses. Additionally, for enhancing the capabilities of harmonic attenuation and resonance damping, it is noted for higher Thevenin impedance systems (Case 1) that the proposed filter design has considerably lower values of the tuning harmonic order  $h$  and the main capacitor reactance  $X_{C1}$  compared to the lower Thevenin impedance systems. This is not the case for the conventional STPF filter design.

For both approaches, acceptable values of  $PF$  and  $dPF$  are achieved, as shown in **Table 2** and **Table 4**. Moreover, remarkable reductions in the values of  $THD_V$ ,  $TL$ , and  $I_S$  are obvious. The  $THD_I$  percentages meet the IEEE limits. Besides, it is notable, as shown in **Table 3** and **Table 4**, that the main capacitors' loading values comply with the IEEE Standard 18-2012 limits. Thus, all the constraints are satisfied.

On the other hand, the two approaches differ as given below:

The  $THD_V$  and  $TL$  values observed for the proposed approach are lower than the corresponding values observed for the conventional one in the two studied cases for the presented passive filters. Additionally, their values observed for the CTPF are lower than the corresponding values observed for the STPF for the two approaches in the two studied cases.

The  $THD_I$  values observed for the proposed approach are higher than the  $THD_I$  values observed for the conventional one in the two studied cases. However, the  $THD_I$  values observed for both approaches comply with the IEEE 519 limits. **Fig. 3** shows the simulated results of the compensated supply current harmonic contents for both approaches in the two cases for the

two presented filters, respectively. Unlike what might be expected in such a case, the proposed CTPF design is more consistent with the individual current harmonic limits of the IEEE Standard 519 compared to the conventional one, validating that using  $IHD_i$  and  $THD_i$  limits in the optimization problem as constraints is usually better than minimizing  $THD_i$  as an objective function, and also showing that the filtering percentage is not a good index, since it describes only the filter effectiveness at one frequency number but does not describe the behaviour of the filter over a wide frequency range. However, this is not true in the case of multiple-arm passive filters.

Additionally, it can be easily noted in **Fig. 3** that the performance of the presented CTPF and STPF using the proposed approach in the higher frequency range is more satisfactory than that of the conventional design approach. However, the performance of the proposed CTPF appears more promising, this is because the proposed CTPF absorbs much a broader range of dominant harmonics.

The proposed CTPF satisfies what is expected from it in the lower frequency range, while maintaining its ability as a high-pass filter in the higher frequency range, compared to the conventional approach and the traditional STPF. This is due to the fact that the  $FS$  values observed for the proposed approach are lower than the corresponding values observed for the conventional one in the two studied cases. Moreover, the  $FS$  values observed for the CTPF are considerably lower than the corresponding values observed for the STPF one in the two studied cases. The difference between the  $FS$  values in the two approaches reflects the resonance damping capabilities of each of them. It should be mentioned that this difference was expected, since the STPFs are not damped filters. On the other hand, the CTPFs attain less attenuation than single-tuned filters for the same tuning frequency, thus lower filtering percentages are provided with them.

For the CTPF, it is evident that the difference between the  $FS$  values in the two approaches cannot be considered trivial. Thus, one can consider that both approaches can achieve similar performances in harmonics mitigation and power factor correction, but the proposed approach has an additional advantage in damping the series and parallel resonances. This is obvious in **Fig. 4**, which shows impedance-frequency scans of the magnitudes of the equivalent impedances seen from the harmonic source side for both filters in the two cases, respectively.

As shown in **Fig. 4**, the damping resistance of the CTPFs can reduce the peak of the parallel resonance effectively rather than shifting it to a less hazardous frequency as in STPFs. Additionally, the same figure validates that the impedance-frequency response of the conventional CTPFs can be very similar to the STPFs, especially for distribution systems having low short-circuit capacities.

For the STPF, despite it is not a damped type filter, it is observed that the proposed approach may have a marginal credit in damping the parallel resonance.

From the series resonance viewpoint, **Fig. 5** shows the impedance-frequency scan of magnitudes of the equivalent impedances seen from the utility side for both filters in the two cases, respectively. It is obvious that responses observed for the proposed approach have no tendency to initiate series resonance compared to responses observed for the conventional approach for both filters in the two studied cases.

Besides, the proposed approach obviously has a better ability to attenuate a broad range of harmonic frequencies generated by nonlinear loads. However, the proposed CTPFs guarantee that harmonic-resonance risk is non-existent. It must be mentioned that the harmonic number is limited to 20 in **Fig. 5** to give a close view of the concerned region. Ref. [15] recommends that values of  $m$  should be around 4 for harmonics mitigation using CTPFs, as they may be a suitable passive choice, and less than 20 to achieve the highest performance of the damped CTPFs. Recalling the  $m$  values given in **Table 3**, it is

obvious that the  $m$  values for the proposed approach are lower than the corresponding values observed for the conventional one in the two studied cases. Hence, one may conclude that the CTPF's resonance damping rises as  $m$  and  $FS$  values decrease.

From another viewpoint, the difference in  $m$  values observed between the two approaches for the system under study in Case 2 was small, as they have similar resonance damping capabilities, as shown in **Figs. 4(b)** and **5(b)**. Recalling **Table 3** and **Table 4** again, lower values of capacitive reactance or higher reactive power supplied by the filters are observed for the proposed approach, leading to higher percentages of the true power factor compared to the conventional one. Thus, one can conclude that CTPFs may need high reactive-power compared to the STPFs to enhance their harmonic compensation and resonance damping capabilities and thus to minimize the reactive-powers share of other filters combined with them, if they exist.

From the point of view of filter power losses, values observed for the proposed approach are higher (almost three times more) than corresponding values for the conventional approach because of the low values of  $R_d$ , or the increased resonance damping capabilities for the CTPF. Additionally, for the proposed CTPF: Case 1, with the same harmonic tuning order  $h$  and the same capacitor reactance  $X_{C1}$  but with  $R_d$  varies from 1 till a value corresponding to  $m$  equals 20, **Fig. 6** clarifies that the smaller the value of  $FS$ , the higher the value of energy dissipated by the filter's resistance is. Thus, one may conclude that the CTPF's investment cost increases as the resonance damping capabilities rise because the energy loss charges will increase, due to the increased loss of the CTPF. However, as  $m$  is less than 20, these losses are still less (two or three times) than the corresponding losses for the STPF. This is notable in the filter power loss values shown in **Table 3** and **Table 4** for both filters.

Traditionally, passive filters struggle with system impedance changes. Also, a passive filter may sink specific harmonic currents from other neighbouring nonlinear loads on the same bus or from the power system upstream of the filter. This may cause an overload to the filter, and then will be ineffective. Moreover, at light loading conditions, the passive filters also cause problems of voltage regulation, filter overloading and harmonic resonance between line inductors and shunt capacitors installed on the distribution system [19]. The traditional solution in such a case is to disconnect the filters during light load periods. Additionally, dynamic system changes, aging and temperature effects modify the filter inductor and capacitance values [20]. Thus, it is important to analyze the expected performance of the designed filters in the presence of some parameter changes. Consequently, five tests have been examined for the presented filters' parameters given in **Table 3** and **Table 4**: Case 1, as follows:

**Tests 1 and 2:** considering negative and positive 25% change in the Thevenin source impedance, respectively.

**Tests 3 and 4:** considering 75% and 50% loading change, respectively.

**Test 5:** considering positive tolerance of 5% on the capacitors and 2% on the reactors.

**Fig. 7** shows the values of the  $THD_v$ ,  $THD_i$ , and  $FS$  during the latter tests, where subscript '0' represents the actual system, filter and load values. It can be noted in **Fig. 7(a)** that the performance of the proposed CTPF has the advantages of preserving an acceptable voltage quality, while maintaining its ability as a resonance damper filter compared to the conventional one and the STPF for both approaches. Additionally, the lowest change in  $FS$  values is provided by the proposed CTPF under the different tests, therefore, it decreases the effect of variations in system impedance. Moreover, it was observed throughout the load perturbation from full load to half load that the variation in voltage has been contained within a regulation of 3.6%, and swell in the voltage due to light load condition has been averted for CTPF, using both approaches. Additionally, the values of the main capacitors' loading duties all comply with the IEEE Std. 18-2012 limits. On the other side, the values of capacitor' loading duties for the single-tuned filters did not comply with the IEEE Standard 18-2012 limits for the different

loading percentages. This demonstrates the ability of the CTPFs to work effectively for load-varying conditions [7], where so far traditional passive filters fall short. It is obvious in **Fig. 7(a)** and **Fig. 7(c)** that the  $THD_I$  values observed for the proposed approaches are considerably lower than the  $THD_I$  values observed for the conventional approaches, in case of half loading percentage: *Test 4*. Moreover, the effect of the filter parameters change is insignificant for the values of the  $THD_V$ ,  $THD_I$ , and  $FS$  under the previous tests.

Finally, [13] clearly states that most industrial systems can be analyzed with a balanced representation. The loads are balanced three-phase loads, including the harmonic sources. However, balanced system analysis is not valid in many cases such as the use of large single-phase nonlinear loads [21, 22]. Accordingly, small rating series passive/active filters combined with the proposed CTPF can be employed to mitigate the adverse effects of unbalanced and non-sinusoidal voltages on the power quality since they can be used to adjust PCC phase voltages individually. The employability of the series passive filters for the harmonic and unbalance mitigation will be considered in the future works.

## 6. Conclusion

In addition to being able to deal with high order harmonics, the CTPF is useful to create a resonance-free capacitor. In this paper, a new use of an impedance-frequency index to assess the resonance damping capability provided by the damped filters analytically is proposed. The impedance-frequency index can be employed as an indicator to describe the overall performance of the filter and its resonance damping capability. In addition to maintaining harmonic voltage below their limits and the notable reduction of transmission loss values; design of the CTPF as a resonance damper filter offers a remarkably enhanced capability of resonance damping, less concern to parameter variations and filter overloading. This may be useful for varying load conditions in industrial applications. Finally, more investigations considering the resonance damping capability provided by the damped CTPF and its power loss under unbalanced and non-sinusoidal conditions should be performed. This point is currently under study and will be presented in future work.

## 7. References

- [1] Sher HA, Addoweesh KE, and Khan KE (2013) *Harmonics Generation, Propagation and Purging Techniques in Non-Linear Loads*. In: Dr. Dylan Lu (Ed.) *An Update on Power Quality*, InTech, Croatia - European Union. doi: 10.5772/53422
- [2] Das JC (2015) *Power System Harmonics and Passive Filter Design*. Wiley-IEEE Press, Hoboken, New Jersey, United States.
- [3] Abdel Aleem SHE, Ibrahim AM, and Zobaa AF (2016) Harmonic assessment-based adjusted current total harmonic distortion. *IET J Eng*. doi: 10.1049/joe.2016.0002
- [4] Saleh SM, Ibrahiem KH, Eiteba MBM (2016) Economic aspects for multi-step LC compensator with uncertain load characteristics using genetic algorithm. *IET Gener Transm Dis* . doi: 10.1049/iet-gtd.2015.0996
- [5] Nassif AB, Xu W, and Freitas W (2009) An Investigation on the Selection of Filter Topologies for Passive Filter Applications. *IEEE T Power Deliver* 24: 1710–1718. doi: 10.1109/TPWRD.2009.2016824
- [6] Zobaa AF (2014) Optimal multiobjective design of hybrid active power filters considering a distorted environment. *IEEE T Ind Electron* 61: 107–114. doi: 10.1109/TIE.2013.2244539
- [7] Dugan RC, McGranaghan MFS, and Beaty HW (2002) *Electric Power Systems Quality*. McGraw-Hill, New York.

- [8] Abdel Aleem SHE, Zobaa AF, and Abdel Aziz MM (2012) Optimal C-Type Passive Filter Based on Minimization of the Voltage Harmonic Distortion for Nonlinear Loads. *IEEE T Ind Electron* 59: 281–289. doi: 10.1109/TIE.2011.2141099
- [9] Mohamed IF, Abdel Aleem SHE, Ibrahim AM, and Zobaa AF (2014) Optimal Sizing of C-type Passive Filters under Non-sinusoidal Conditions. *Energy Technology & Policy* 1: 35–44. doi:10.1080/23317000.2014.969453
- [10] Balci ME (2014) Optimal C-Type Filter Design to Maximize Transformer's Loading Capability under Non-sinusoidal Conditions. *Electr Pow Compo Sys* 42: 1565–1575. doi: 10.1080/15325008.2014.943827
- [11] Zhou JL, Tits AL, Lawrence CT (1997) *User's Guide for FFSQP Version 3.7: A FORTRAN Code for Solving Optimization Problems, Possibly Minimax, with General Inequality Constraints and Linear Equality Constraints, Generating Feasible Iterates*, TR-92-107r5, Institute for Systems Research, University of Maryland, College Park, MD 20742, USA.
- [12] Abdel Aziz MM, El-Zahab EEA, Zobaa AF, and Khorshied DM (2007) Passive harmonic filters design using FORTRAN feasible sequential quadratic programming. *Electr Pow Syst Res* 77: 540–547. doi:10.1016/j.epsr.2006.05.002
- [13] IEEE Standard 519 (1992) IEEE Recommended Practice and Requirements for Harmonic Control in Electrical Power Systems.
- [14] Xiao Y, Zhao J, and Mao S (2004) Theory for the Design of C-type Filter. In *11th Int. Conf. Harmonics and Quality of Power*, ICHQP 2004, Lake Placid, New York, Sept. 12–15, pp. 11–15. doi: 10.1109/ICHQP.2004.1409321
- [15] Aravena P, Vallebuona G, Moran L, Dixon J, and Godoy O (2009) Passive Filters for High Power Cycloconverter Grinding Mill Drives. In *Industry Applications Society Annual Meeting, IAS 2009*, Houston, TX, Oct. 4–8, pp. 1–7. doi: 10.1109/IAS.2009.5324939
- [16] Zobaa AF, and Abdel Aleem SHE (2014) A New Approach for Harmonic Distortion Minimization in Power Systems Supplying Nonlinear Loads. *IEEE T Ind Inform* 10: 1401–1412. doi: 10.1109/TII.2014.2307196
- [17] IEEE Standard 18 (2012) IEEE Standard for Shunt Power Capacitors.
- [18] Zhenyu Huang, Wilsun Xu, Dinavahi VR (2003) A Practical Harmonic Resonance Guideline for Shunt Capacitor Applications. *IEEE T Power Deliver* 18: 1382–1387. doi: 10.1109/TPWRD.2003.817726
- [19] Akagi H (1996) New Trends in Active Filters for Power Conditioning. *IEEE T Ind Appl* 32: 1312–1322. doi:10.1109/28.556633
- [20] Pinceti P, and Prando D (2015) Sensitivity of parallel harmonic filters to parameters variations. *INT J Elec Power* 68: 26–32. doi:10.1016/j.ijepes.2014.12.030
- [21] Gokozan H, Taskin S, Seker S, Ekiz H (2015) A neural network based approach to estimate of power system harmonics for an induction furnace under the different load conditions. *Electr Eng*. 97: 111–17. doi:10.1007/s00202-014-0320-3
- [22] Balci ME, Abdel Aleem SHE, Zobaa AF, and Sakr S (2014) An Algorithm for Optimal Sizing of the Capacitor Banks under Non-sinusoidal and Unbalanced Conditions. *Recent Advances Elec. & Electronic. Eng.* 7: 116–22. doi: 10.2174/2352096507666140925202729

Figures

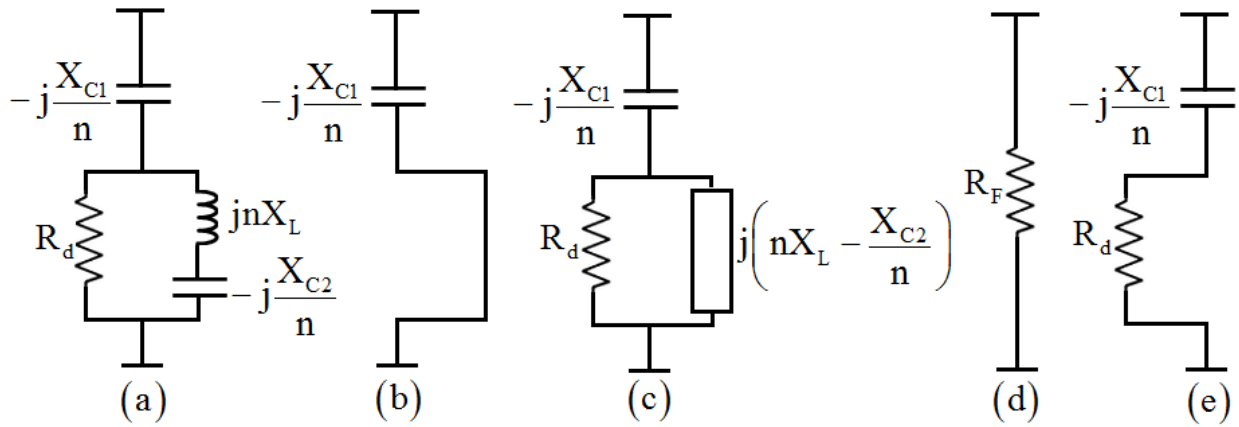

**Fig. 1.** Main features of C-type harmonic filters

- (a) CTPF
- (b) CTPF at the fundamental frequency
- (c) The CTPF nearly works as a second-order filter as the frequency increases
- (d) The CTPF at its resonant-frequency acts as a resistance  $R_F$
- (e) At higher frequencies, the CTPF nearly acts as a first-order filter

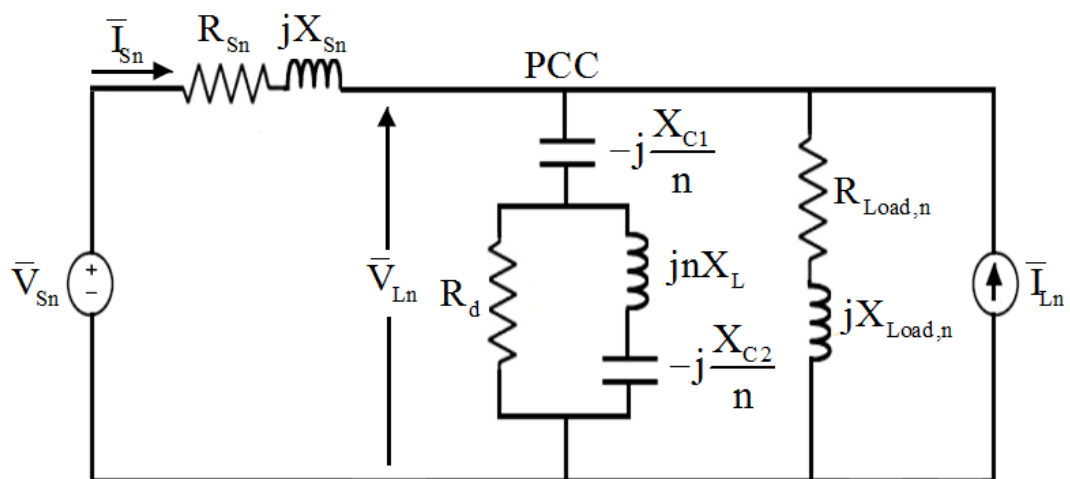
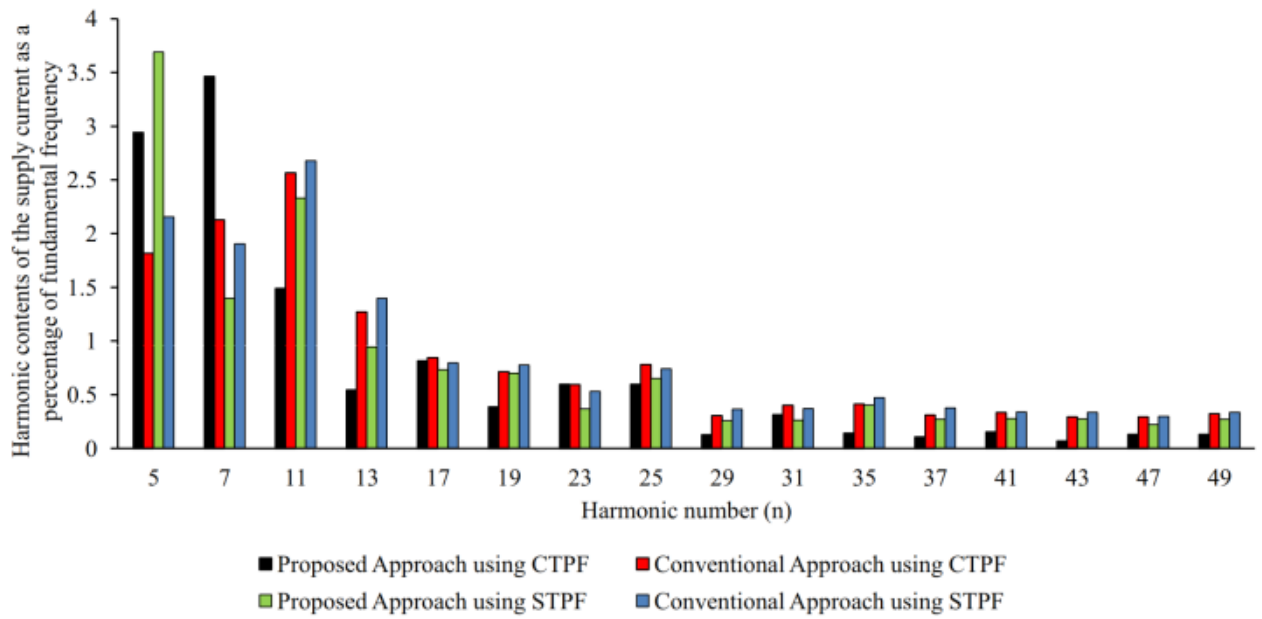
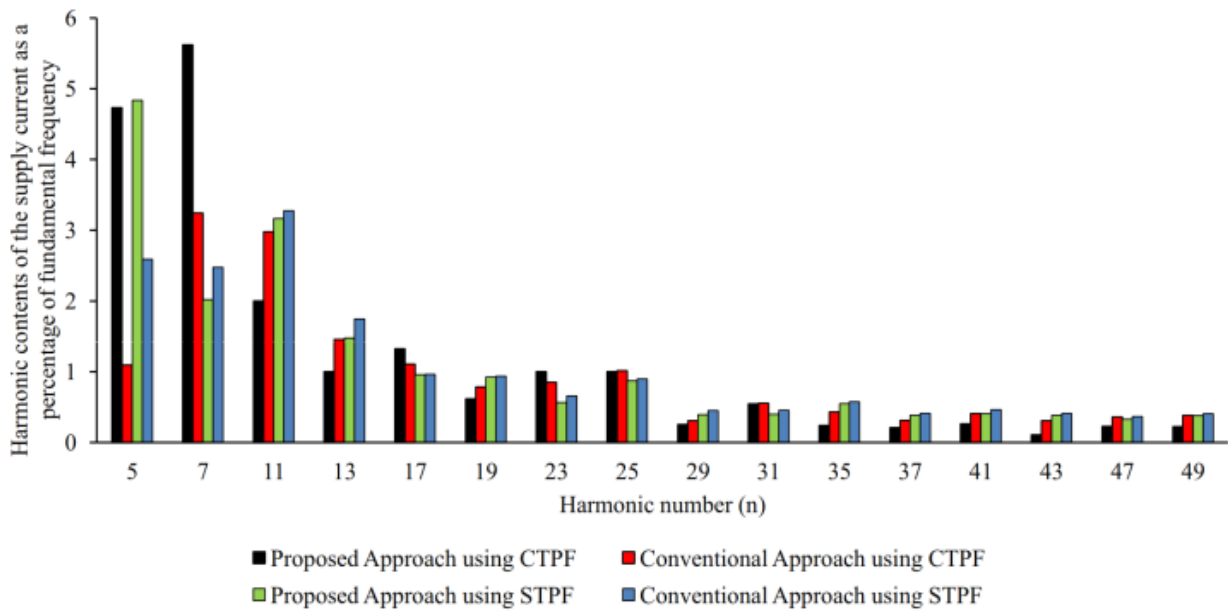

Fig. 2. Configuration of the compensated system



(a)



(b)

**Fig. 3.** Harmonic contents of the supply current for both approaches using CTPF and STPF

(a) Case 1

(b) Case 2



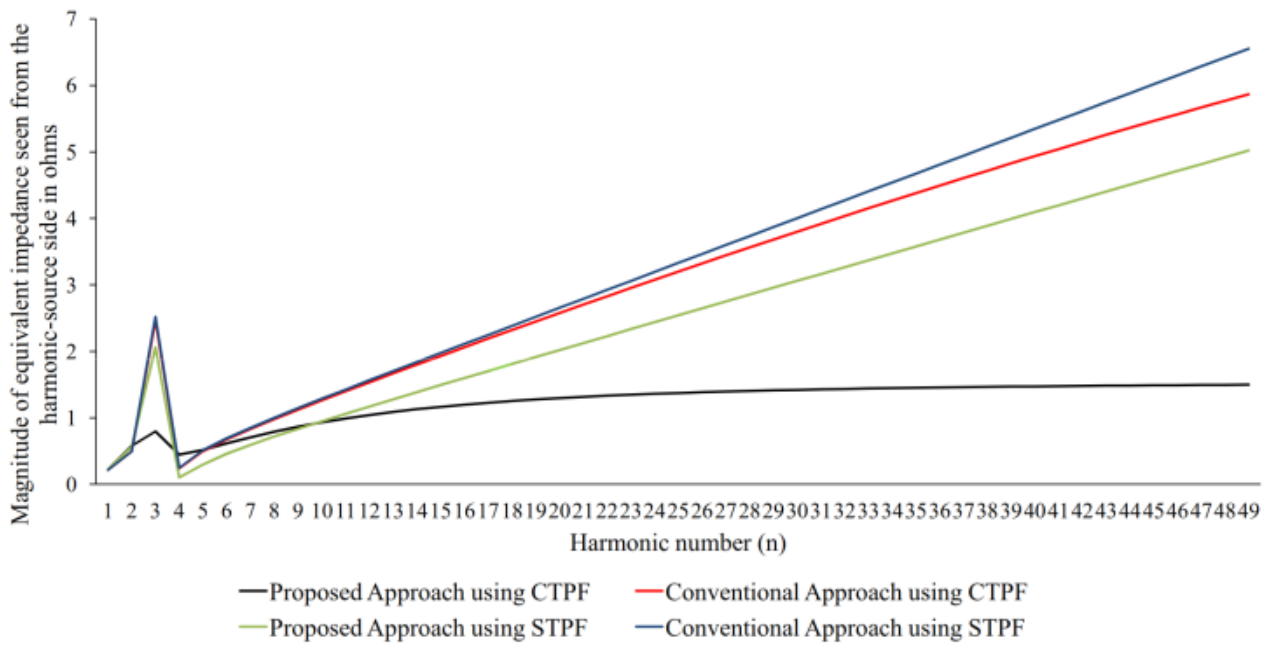

(a)

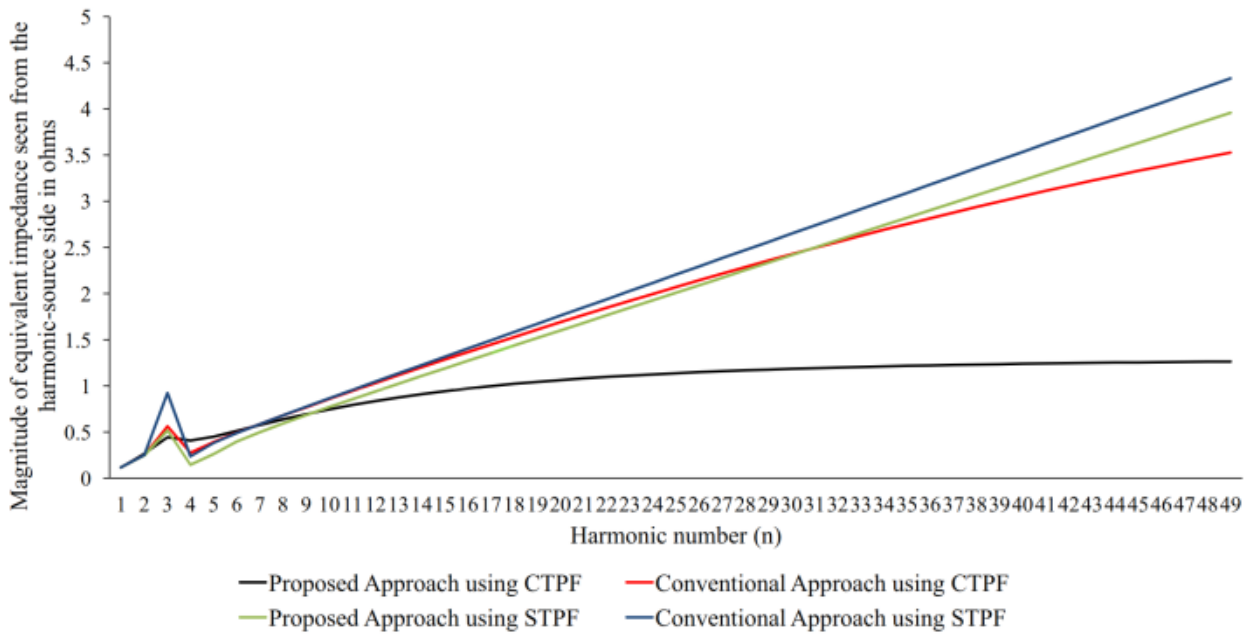

(b)

**Fig. 4.** The equivalent impedance seen from the harmonic-source side versus harmonic number of both approaches using CTPF and STPF

(a) Case 1

(b) Case 2

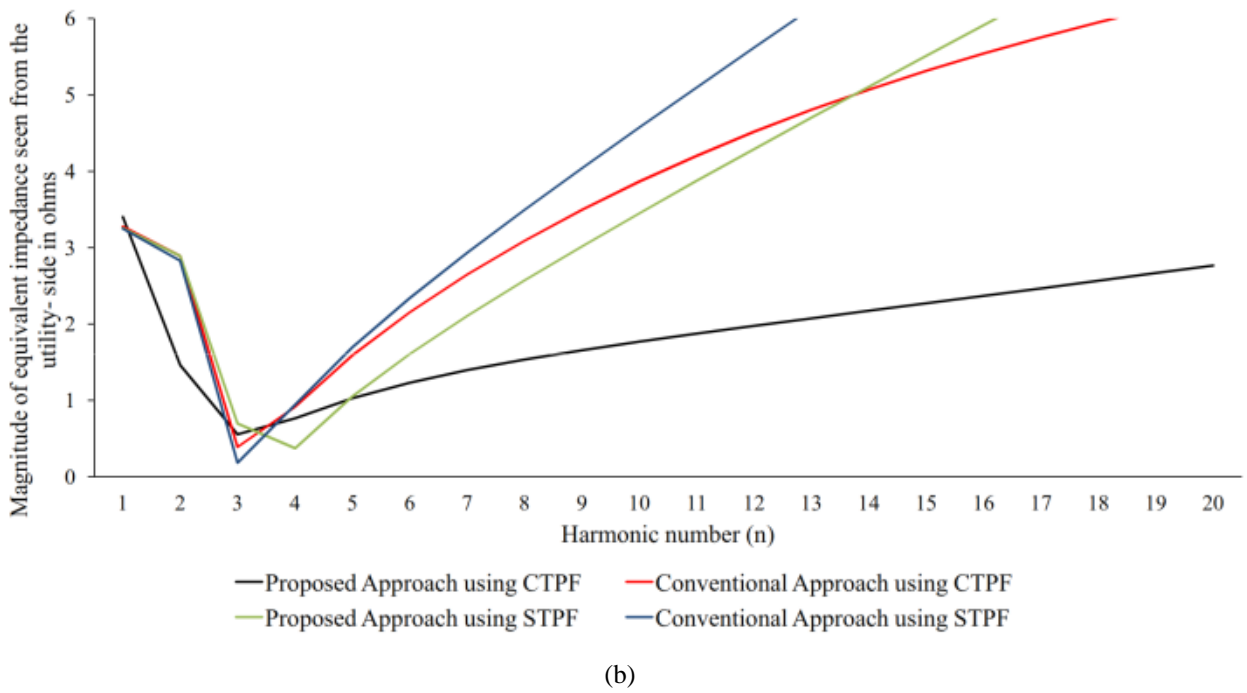
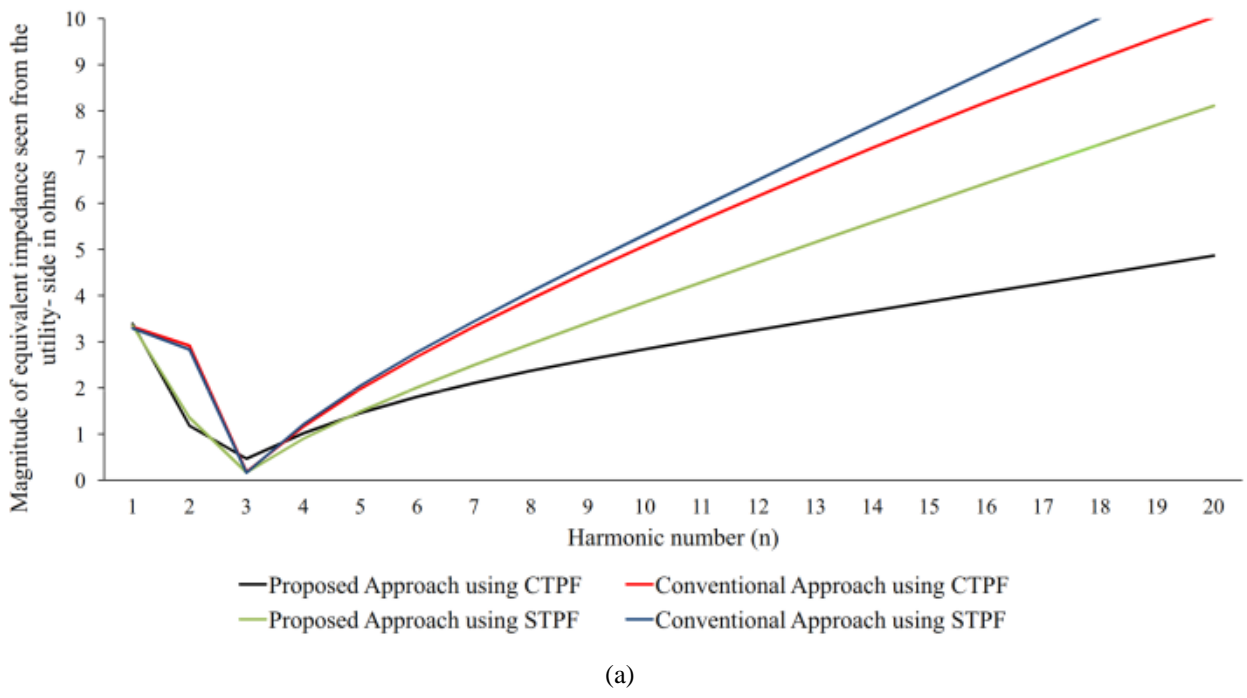

**Fig. 5.** The equivalent impedance seen from the utility- side versus harmonic number of both approaches using CTPF and STPF  
 (a) Case 1  
 (b) Case 2

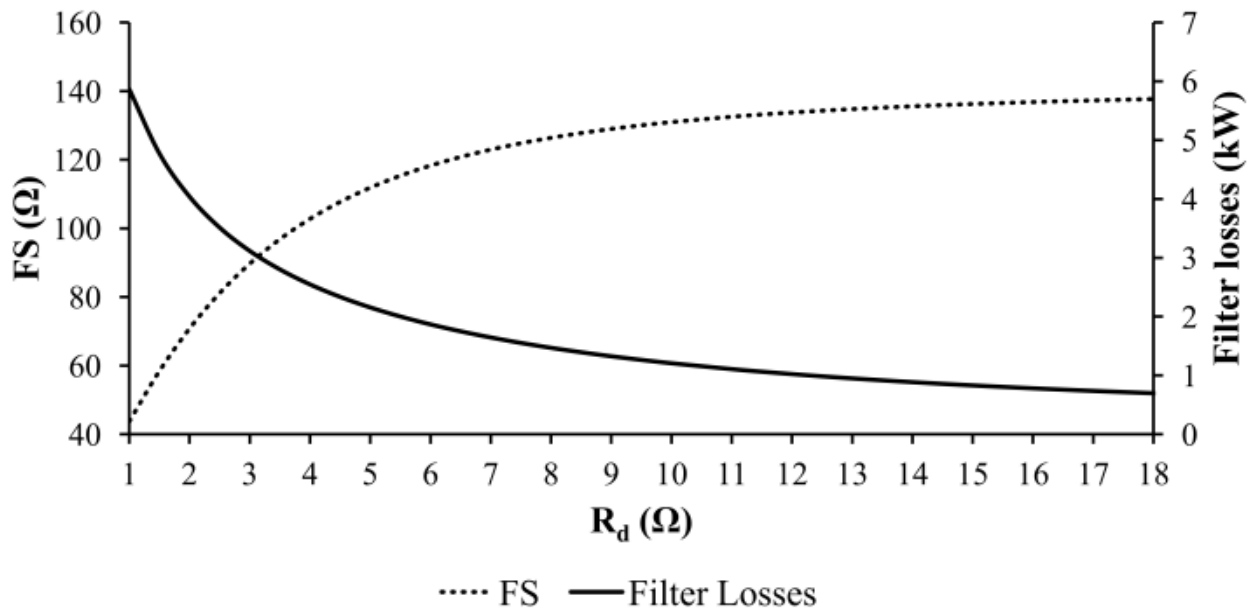

**Fig. 6.** Illustrations of the FS index and the filter losses in case of variation of the damping resistance for the proposed approach using CTPF: Case 1

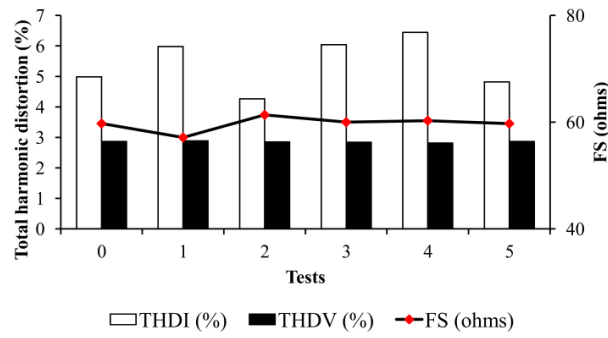

(a) Proposed approach using CTPF

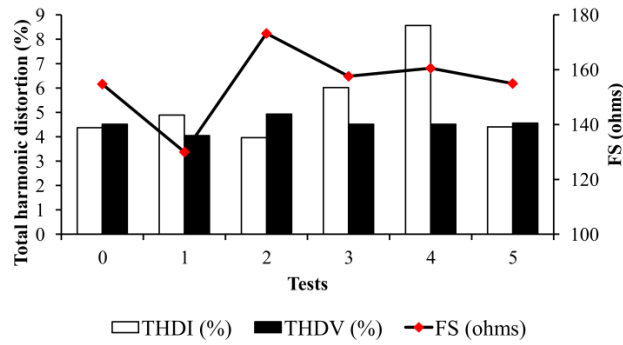

(b) Conventional approach using CTPF

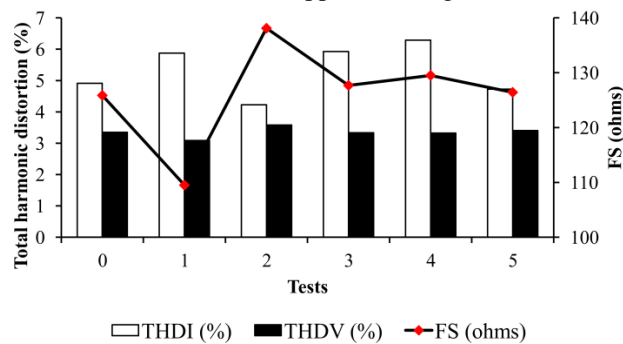

(c) Proposed approach using STPF

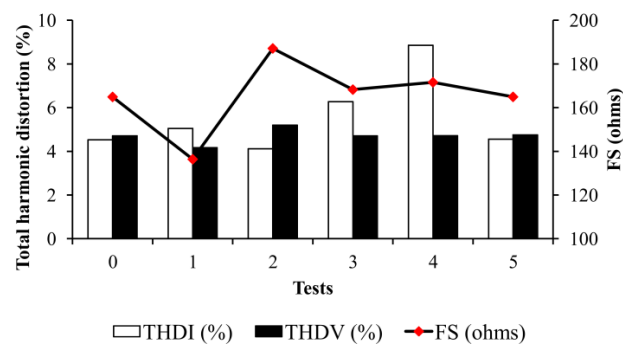

(d) Conventional approach using STPF

**Fig. 7.** The  $THD_V$ ,  $THD_I$ , and FS values during the tests: Case 1

- (a) Proposed approach using CTPF
- (b) Conventional approach using CTPF
- (c) Proposed approach using STPF
- (d) Conventional approach using STPF