



**UPS System: How Current and Future Technologies
Can Improve Energy Efficiency in Data Centres**

**Submitted in partial fulfilment of the requirements
for the degree of Doctor of Philosophy**

By

MUFTAH A MILAD

Supervised by:

Dr MOHAMED DARWISH

**Department of Electronic and Computer Engineering
College of Engineering, Design and Physical Sciences
Brunel University London**

May, 2017

ABSTRACT

A data centre can consist of a large group of networked servers and associated power distribution, networking, and cooling equipment, all that application consumes enormous amounts of energy as a small city, which are driving to a significant increase in energy inefficiency problems in data centre, and high operational costs. Also the massive amounts of computation power contained in these systems results in many interesting distributed systems and resource management problems.

In recent years, research and technologies in electrical engineering and computer science have made fast progress in various fields. One of the most important fields is the energy consumption in data centre. In recent years the energy consumption of electronic devices in data centre, as reported by. Choa, Limb and Kimb, nearly 30000000 kWh of power in a year, may consume by a large data centre and cost its operator around £3,000,000 for electricity alone. Some of the UK sites consume more than this. In the UK data centre the total power required are amid 2-3TWh per year. Energy is the largest single component of operating costs for data centres, varying from 25-60%.

Agreeing to many types of research, one of the largest losses and causes of data centre energy inefficiency power distribution is from the uninterruptible power supply (UPS). So a detailed study characterized the efficiencies of various types of UPSs under a variety of operating conditions, proposed an efficiency label for UPSs, also investigate challenges related to data centre efficiency, and how all new technologies can be used to simplify deployment, improve resource efficiency, and saving cost.

Data centre energy consumption is an important and increasing concern for data centre managers and operators. Inefficient UPS systems can contribute to this concern with 15 percent or more of utility input going to electrical waste within the UPS itself. For that reason, maximizing energy efficiencies, and reduce the power consumption in a data centre has become an important issue in saving costs and reducing carbon footprint, and it is necessary to reduce the operational costs.

This study attempts to answer the question of how can future UPS topology and technology improve the efficiency and reduce the cost of data centre. In order to study the impact of different UPS technologies and their operating efficiencies. A model for a medium size data centre is developed, and load schedules and worked diagrams were created to examine in

detail and test the components of each of the UPS system topologies. The electrical infrastructure topology to be adopted is configured to '2N' and 'N+1' redundancy configuration for each UPS systems technologies, where 'N' stands for the number of UPS modules that are required to supply power to data centre. This work done at RED engineering designs company. They are professionals for designing and construction of a new Tier III and Tier IV data centres.

The aim of this work is to provide data centre managers with a clearer understanding of key factors and considerations involved in selecting the right UPS to meet present and future requirements.

TABLE OF CONTENTS

ABSTRACT.....	i
TABLE OF CONTENTS.....	iii
LIST OF FIGURES.....	vii
LIST OF TABLES.....	ix
LIST OF ABBREVIATIONS.....	x
ACKNOWLEDGMENTS.....	xi
DECLARATION.....	xii
PUBLICATIONS AND CONFERENCE.....	xiii
Chapter 1: INTRODUCTION.....	1
1.1 Background and Motivation.....	1
1.2 Research Aim and Objective.....	2
1.3 Research Contribution.....	4
1.4 Thesis Outline.....	6
Chapter 2: LITERATURE REVIEW.....	7
2.1 Data centre background.....	7
2.2 Data centre availability classification system and standard.....	9
2.2.1 Tier I data centre.....	10
2.2.2 Tier II data centre.....	10
2.2.3 Tier III data centre.....	10
2.2.4 Tier IV data centre.....	11
2.3 Data centre power system.....	12
2.4 Uninterruptible power supplies design and topology.....	13
2.4.1 Rectifiers.....	14
2.4.2 Inverter.....	14
2.4.3 Battery sets.....	15
2.4.4 Static bypasses switch.....	15
2.5 Double conversion static UPS type.....	17
2.6 Uninterruptible power supply operating modes in double conversion.....	18
2.6.1 Normal mode.....	18
2.6.2 Stored or battery backup mode.....	19
2.6.3 Bypass mode.....	19

2.6.4 Operating the Double conversion UPS in ECO mode.....	20
2.7 Flywheel energy storage system UPS	21
2.8 Cost comparison.....	24
2.9 Uninterruptible power supply configurations types.....	24
2.9.1 What does ‘N’ standing for and mean?	24
2.9.2 Capacity ‘N’ system configuration	24
2.9.3 Parallel UPS redundancy configuration ‘N+1’ and ‘2N’.....	25
2.9.4 ‘N+1’ parallel redundancy configuration	26
2.9.5 ‘2N’ parallel redundancy configuration	27
2.10 Data centre energy efficiency	29
2.10.1 Power Usage Effectiveness (PUE)	30
2.10.2 Data Centre Infrastructure Efficiency (DCIE).....	31
2.11 Summary	32
Chapter 3: METHODOLOGY AND BACKGROUND.....	33
3.1 Introduction	33
3.2 ‘ROMONET’ Computer based software programs.....	34
3.2.1 Romonet software functional description	34
3.2.2 Key features and benefits	34
3.3 What is ‘N’ capacity system configuration.....	35
3.3.1 ‘N+1’ Parallel redundancy configuration	37
3.3.2 ‘2N’ Parallel redundancy configuration	37
3.4 Tier III facility.....	38
3.5 Power Usage Effectiveness	40
3.6 Data centre infrastructure efficiency.....	40
3.7 Data centre energy and uninterruptible power supply (UPS) cost.....	41
3.8 Summary	41
Chapter 4: DESIGN DESCRIPTION FOR 2N REDUNDANCY CONFIGURATION	42
4.1 Introduction	42
4.2 Design description.....	43
4.3 2N Redundancy configuration diagram for a medium data centre	44
4.4 Double conversion UPS system based on 2N redundancy configuration.....	46
4.4.1 ‘2N’ Redundancy configuration for static UPS system diagram	47
4.4.2 The power usage effectiveness (PUE) of the 2N redundancy configuration static UPS	50

4.4.3 The effect on the system cost	51
4.4.4 Static double conversion UPS, operational and maintenance cost	53
4.5 Flywheel UPS system based on 2N redundancy configuration.....	53
4.5.1 '2N' Redundancy configuration for flywheel UPS system diagram	55
4.5.2 The power usage effectiveness (PUE) of the 2N redundancy configuration flywheel UPS	58
4.5.3 The effect on the system cost	59
4.5.4 Flywheel UPS technology, operational and maintenance cost.....	60
4.6 Comparative analysis of the double conversion and flywheel UPS based on '2N' configuration	61
4.6.1 Efficiency comparison of the two UPS technology based on '2N' redundancy configuration	61
4.6.2 Power usage effectiveness comparison of the Two UPS based on '2N' redundancy configuration.....	62
4.6.3 Cost comparison of the two UPS technology based on '2N' redundancy configuration.....	62
4.7 Summary	64
Chapter 5: : DESIGN DESCRIPTION FOR N+1 REDUNDANCY CONFIGURATION	66
5.1 Introduction	66
5.2 Double conversion UPS system calculation based on N+1 redundancy configuration	67
5.2.1 'N+1' Redundancy configuration for static UPS system diagram	68
5.2.2 The power usage effectiveness of the N+1 redundancy configuration static UPS	72
5.2.3 The effect on system cost	73
5.3 Flywheel UPS system calculation based on N+1 redundancy configuration	75
5.3.1 'N+1' Redundancy configuration for flywheel UPS system diagram	76
5.3.2 The power usage effectiveness (PUE) of the N+1 redundancy configuration flywheel UPS.....	79
5.3.3 The effect on the system cost	80
5.4 Comparative analysis of the static and flywheel ups for 'N+1' redundancy configuration	82
5.4.1 Two UPS technology efficiency comparison 'N+1' redundancy configuration	82
5.4.2 Power Usage Effectiveness (PUE) comparison '2N' redundancy configuration	83
5.4.3 Two UPS technology energy cost comparison based on 'N+1' redundancy configuration	84
5.5 Summary	86
Chapter 6: COMPARATIVE ANALYSIS BETWEEN 'N+1' CONFIGURATION AND '2N' CONFIGURATION IN TERMS OF EFFECICNECY, PUE, AND COST.	87

6.1 Introduction	87
6.2 Double conversion UPS system based on 2N and N+1 redundancy configuration comparison.	88
6.2.1 Double conversion UPS system efficiency comparison based on 2N and N+1 redundancy configuration.....	88
6.2.2 Double conversion system applied in 2N and N+1 redundancy configuration comparison in terms of power usage effectiveness.	89
6.2.3 Data centre energy cost comparison based on double conversion UPS system applied in 2N and N+1 redundancy configuration.	91
6.2.4 Double conversion UPS system cost comparison based on 2N and N+1 redundancy configuration.....	92
6.3 Flywheel UPS system comparison based on 2N and N+1 redundancy configuration.	93
6.3.1 Flywheel UPS system efficiency comparison based on 2N and N+1 redundancy configuration.....	94
6.3.2 Flywheel UPS system applied in 2N and N+1 redundancy configuration comparison in terms of power usage effectiveness (PUE).....	95
6.3.3 Data centre energy cost comparison based on flywheel UPS system applied in 2N and N+1 redundancy configuration.....	96
6.3.4 Double conversion UPS system cost comparison based on 2N and N+1 redundancy configuration.....	97
6.4 Summary	99
Chapter 7: CONCLUSIONS AND FUTURE RESEARCH	100
7.1 Discussion and Conclusion	100
7.1.1 Double conversion static UPS and flywheel UPS system in 2N configuration in a medium size data centre	101
7.1.2 Double conversion static UPS and flywheel UPS system in N+1 configuration in a medium size data centre	102
7.1.3 An N+1 and 2N redundancy configuration efficiency comparative	102
7.2 Recommendations and Future Work.....	103
7.2.1 Use the Tier IV level instead of Tiers III.....	104
7.2.2 Increase the lifecycle period ten years instead of five years	104
7.2.3 Large size data centre with 6000 kW of IT load instead of medium size with 1500 kW ...	104
REFERENCES	105

LIST OF FIGURES

Figure 1.1: Data centres energy consumption proportions [13]	2
Figure 1.2: Thesis Outline.....	6
Figure 2.1: Core site data centre [3].	8
Figure 2.2: Infrastructure Tier III classification [42]	11
Figure 2.3: Infrastructure Tier IV classification [42].....	12
Figure 2.4: A typical rectifier symbol	14
Figure 2.5: A typical inverter symbol	15
Figure 2.6: Battery set symbol	15
Figure 2.7: Static switch in online UPS double conversion type [59].....	16
Figure 2.8: Static switch for bypass mode [59]	17
Figure 2.9: Double conversion static UPS system	18
Figure 2.10: Double conversion static UPS system operating modes [65]	20
Figure 2.11: Double conversion UPS in multi operation modes [2].....	21
Figure 2.12: Structure of a conventional flywheel [68]	22
Figure 2.13: Flywheel energy storage system in UPS [75]	23
Figure 2.14: Capacity 'N' system configuration	25
Figure 2.15: 'N+1' parallel redundancy configuration	26
Figure 2.16: '2N' parallel redundancy configuration	28
Figure 2.17: Google data centre power usage effectiveness measurement [91].....	30
Figure 3.1: Capacity 'N' system configuration	36
Figure 3.2: Infrastructure Tier III classifications.....	39
Figure 4.1: Static UPS efficiency curve	46
Figure 4.2: '2N' Redundancy configuration static UPS diagram in a medium data centre.....	48
Figure 4.3: Static UPS efficiency at design load	50
Figure 4.4: the PUE of the 2N configuration static UPS at design load.....	51
Figure 4.5: Static UPS cost in different loads	52
Figure 4.6: Total energy cost in different loads static technology.....	52
Figure 4.7: Flywheel UPS efficiency curve.....	54
Figure 4.8: '2N' Redundancy configuration flywheel UPS diagram in a medium data centre.....	56
Figure 4.9: Flywheel UPS efficiency at design load	57
Figure 4.10: the PUE of the 2N configuration flywheel UPS at design load	58
Figure 4.11: Flywheel UPS cost in different loads.....	59
Figure 4.12: Total energy cost in different loads flywheel technology.....	60
Figure 4.13: Two UPS efficiency comparison at design loads	61
Figure 4.14: PUE for static and flywheel UPS comparative in 2N configuration	62
Figure 4.15: Static and flywheel UPS cost comparative in 2N configuration.....	63
Figure 4.16: Total energy cost comparative in 2N configuration for two UPS technology	64
Figure 5.1: Static UPS efficiency curve.....	67
Figure 5.2: 'N+1' Redundancy configuration static UPS diagram in a medium data centre.....	69
Figure 5.3: Double conversion static UPS efficiency at design load	71
Figure 5.4: the PUE of the N+1 configuration static UPS at design load.....	72
Figure 5.5: Static UPS cost in different loads N+1 configuration	74
Figure 5.6: Total energy cost in different loads static technology.....	74
Figure 5.7: Flywheel UPS efficiency curve.....	75
Figure 5.8: 'N+1' Redundancy configuration flywheel UPS diagram in a medium data centre.....	77
Figure 5.9: Flywheel UPS efficiency at design load	79
Figure 5.10: the PUE of the N+1 configuration flywheel UPS at design load.....	80

Figure 5.11: Flywheel UPS cost in different loads N+1 configuration.....	81
Figure 5.12: Total energy cost in different loads flywheel technology.....	81
Figure 5.13: Two UPS technologies efficiency comparison N+1 configuration efficiency.....	82
Figure 5.14: PUE for static and flywheel UPS comparative in N+1 configuration.....	83
Figure 5.15: Static and flywheel UPS cost comparative in N+1 configuration.....	84
Figure 5.16: Total energy cost comparative in N+1 configuration for two UPS technology	85
Figure 6.1: Static UPS efficiency comparison based on 2N and N+1 configuration.....	89
Figure 6.2: Static UPS PUE comparison based on 2N and N+1 configuration.....	90
Figure 6.3: Data centre energy cost comparison based on 2N and N+1 configuration.....	92
Figure 6.4: Static UPS cost comparison based on 2N and N+1 configuration	93
Figure 6.5: Flywheel UPS efficiency comparison based on 2N and N+1 configuration	94
Figure 6.6: Flywheel UPS PUE comparison based on 2N and N+1 configuration	96
Figure 6.7: Data centre energy cost comparison Based on flywheel Applied in 2N and N+1 configuration.....	97
Figure 6.8: Flywheel UPS cost comparison based on 2N and N+1 configuration	98

LIST OF TABLES

Table 2.1: Summarized the four tier level definition for data centre [31].....	9
Table 4.1: Electrical Loading Summary for Data Centre	43
Table 4.2:1100 kVA Static UPS efficiency from 5% up to maximum capacity	46
Table 4.3: Static UPS findings in 2N redundancy configuration.....	49
Table 4.4: the PUE findings for the static UPS in 2N redundancy configuration	50
Table 4.5: Date centre energy and the static UPS cost findings	51
Table 4.6: Double conversion static UPS operational and maintenance cost in 2N configuration	53
Table 4.7: 1000 kVA flywheel UPS efficiency from 5% up to maximum capacity.....	54
Table 4.8: Flywheel UPS findings in 2N redundancy configuration	57
Table 4.9: the PUE findings for the flywheel UPS in 2N redundancy configuration	58
Table 4.10: Date centre energy and the flywheel UPS cost findings	59
Table 4.11: Flywheel UPS technology operational and maintenance cost in 2N configuration.....	60
Table 5.1: Static UPS findings in N+1 redundancy configuration.....	70
Table 5.2: the PUE findings for the static UPS in N+1 redundancy configuration	72
Table 5.3: the date centre energy and the static UPS cost findings N+1 configuration	73
Table 5.4: Flywheel UPS findings in N+1 redundancy configuration	78
Table 5.5: the PUE findings for the flywheel UPS in N+1 redundancy configuration	79
Table 5.6: The effect on flywheel UPS cost findings in N+1 configuration	80
Table 6.1: Static UPS efficiency comparison between 2N and N+1 redundancy configuration	88
Table 6.2: Static UPS power usage effectiveness comparison based on 2N and N+1 configuration	90
Table 6.3: Date centre energy cost comparison based on static UPS applied in 2N and N+1 configuration.....	91
Table 6.4: Static UPS cost comparison for 2N and N+1 configuration.....	92
Table 6.5: Flywheel UPS efficiency comparison based on 2N and N+1 redundancy configuration	94
Table 6.6: Flywheel UPS power usage effectiveness comparison based on 2N and N+1 configuration	95
Table 6.7: Date centre energy cost comparison based on flywheel applied in 2N and N+1 configuration.....	97
Table 6.8: Flywheel UPS cost comparison based on 2N and N+1 configuration.	98

LIST OF ABBREVIATIONS

Abbreviations	Descriptions
AC	Alternating Current
ATS	Automatic Transfer Switch
CRAC	computer room air conditioners
CT	cooling technology
DC	Direct Current
DCIE	Data Centre Infrastructure Efficiency
FESS	flywheel energy storage system
IGBT	Insulated Gate Bipolar Transistor
IT	information technology
kVA	Kilo-volt Ampere
kW	Kilowatt
MW	Megawatt
PDUS	Power distribution unit system
PF	Power Factor
PSU	Power supply unite
PUE	power usage effectiveness
UPS	Uninterruptible power supply
ASHRAE	American Society of Heating, Refrigerating and Air-conditioning Engineers
VRM	Voltage Regulator Module

ACKNOWLEDGMENTS

I must express my gratitude to my supervisor, Dr. Mohamed Darwish, for the patient guidance, encouragement, feedback, thought, ideas and advice he has provided throughout my time as his student. He was always on hand for guidance. I have been extremely lucky to have a supervisor who cared so much about my research. And he responded to my queries and questions.

I would like to say again a very big thank to Dr Mohamed Darwish. Also, I would like to thank all my family, for continued support and encouragement. I would also like to express my grateful to thank all my friends, colleagues, and the administrative and technical staff in the College of Engineering, Design and Physical Sciences for all their support during my PhD programme.

Finally, I would like to express my appreciation to Jonathon Harte and the staff, at [RED Engineering Design Oxford, UK], for giving me the opportunity to do this work.

DECLARATION

I certify that the work in this thesis has not previously been submitted for a degree nor has it been submitted as part of requirements for a degree. Also, I certify that I have written the work in this thesis. Any help that I have received in my research work and the preparation of the thesis itself has been duly acknowledged and referenced.

Signature of Student

MUFTAH A MILAD

May 2017

PUBLICATIONS AND CONFERENCE

- M. Milad and M. Darwish. “Uninterruptible power supplies system for Data Centre” presented at Brunel University Graduate School, *Research Student Poster Conference* May 15, 2013. Brunel University. London, UK.
- M. Milad and M. Darwish. “Uninterruptible power supplies system for Data Centre”, presented at the *7th Annual Research Student Conference*, Jun 11, 2014. Brunel University. London UK.
- M. Milad and M. Darwish, “UPS System: How Can Future Technology and Topology Improve the Energy Efficiency in Data Centres,” *The 49th International Universities Power Engineering Conference (UPEC2014)*, pp. 1-4. Cluj-Napoca, Romania 2-5 Sept, 2014.
- M. Milad and M. Darwish. UPS System: “Comparison between Double Conversion online UPS and flywheel UPS Technologies in terms of efficiency and cost in a Medium Data Centre” Presented in *the 50th International Universities' Power Engineering Conference (UPEC 2015)*, pp. 1-5. Staffordshire University, UK, September 2015.

Chapter 1: INTRODUCTION

1.1 Background and Motivation

Data centre are physical facilities that are hosting massive numbers of servers and the associated support infrastructure, also can be seen as an information technology (IT) system and supporting infrastructures combined together [1]. The information technology system equipment includes servers, telecommunication and storage systems, to provide services to the end load. And supporting infrastructures include power delivery and cooling technology (CT) systems [2]. The power includes backup power generators, uninterruptible power supplies system (UPSs), and power distribution unit's system (PDUs). And the Cooling Technology systems include server, fans, computer room air conditioners (CRACs), chillers, and cooling towers. The main function of the data centre is to provide reliable power, security, cooling, and network connectivity to computer equipment [3, 4].

In the most recent years, due to the extraordinary development of internet and data centres, power quality is a key viewpoint for an expanding number of critical loads. Also with the advances in cloud computing (outsourcing of computing resources to service providers). The number of data centre employed by these providers will likely to increase. As the number of data centre and demand for these services increase. Also, the energy consumption of servers and network equipment such as, uninterruptible power supply [5, 6] expected to continue slightly increasing in the near future. The issues of maximizing energy efficiency and reduce energy costs become more important. As reported by Koomey [7], reported that infrastructure equipment related to power and cooling may be responsible for about half of total annualized costs. In typical data centre facilities and that this section is growing over time as IT equipment energy use increases and IT equipment costs decline [8, 9].

An analysis of data centre equipment reveals that, on average, only about half the energy consumption is caused by the IT systems themselves [10]. The power and cooling systems in a data centre might account for almost half of the total consumption within the data centre power infrastructure, losses in the UPS may be relevant, with associated burden on the cooling system. In fact, UPS losses may actually account for 8% of the site energy use [11, 12]. Figure. 1.1 indicates how data centre energy is consumed. On the IT front, the increased energy consumption is mainly caused by the considerable rise in the number of servers. The ever-increasing volume of data centre means that energy consumption in the storage sector

has also risen dramatically. In relation to the IT systems, the increased energy consumption is mainly caused by the considerable rise in the number of servers [13, 14].

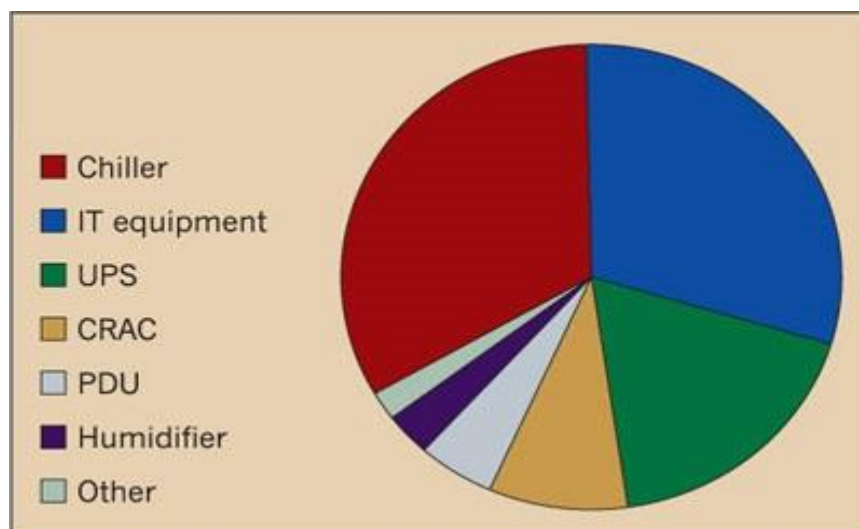

Figure 1.1: Data centres energy consumption proportions [13]

1.2 Research Aim and Objective

The energy supplies or electrical distribution system in a data centre is an important concept. So, data centre managers and operators should understand the basics of the electrical distribution system in their data centre. To save downtime, help to achieve greater efficiency and reduce power problems in data centre. The focus in this work on understanding the factors and considerations involved in selecting the right UPS system. It is important for data centres owners to know how to select a UPS that will be efficient at the actual operating load of their facility and not just its fully rated capacity [10].

Once energy supply or electrical infrastructures energy consumption are optimizations is concerned in a data centre. The UPS is extremely important in reducing the energy consumption of data centre [15]. Also, it is necessary and important as part of a data centre's power supply infrastructure. Provides backup power when utility power fails, either long enough for critical equipment to shut down gracefully so that no data is lost, or long enough to keep required loads operational until a generator comes online [16]. So, in order to clear all concerns, identifying the importance and review the existing UPS technologies deployed in data centres in terms of efficiency and cost, and selecting the right UPS system. A comparison between two UPS types. Double conversion static UPS and flywheel UPS system, in a model of a medium size data centre designed to provide 1500 kW, to the data halls and hence this load support the IT load. To help data centre owners and managers, with a clearer

understanding of key factors and considerations involved in selecting the right UPS system for the right site. As well as, understand how future UPS system topology and technology can improve their data centre in terms of efficiency and cost. To meet present and future requirements.

The static UPS technology used in this work is the double conversion static UPS technology. Which is predominantly used in the data centre industry, and has the capability to operate in the eco-mode. The eco-mode is one of the several UPS modes of operation that can improve data centre efficiency, also known by many other names, including [high efficiency mode, bypass mode and multi-mode] [63].

However, some data centre managers and operators are taking a hard look at UPS which operates in eco-mode and whether if these UPS modes can improve data centre efficiency and save the energy cost, because of the known or anticipated side-effects [63]. This research aims to clear these concerns, by presenting experimental results from testing a real double conversion UPS technology in a model of, a medium size data centre with protection operating in eco- mode.

In order to achieve the research aims, the following objectives have been accomplished:

- An electrical model for a medium size data centre is designed to provide 1500 kW to the data halls. The data centre selected is assumed to be of the modular type operating on free air cooling which has been calculated to be available for 99% of the year in London based on ASHRAE weather data.
- The electrical infrastructure topologies adopted in this work, is [2N and N+1] Parallel redundancy configuration for each of the two UPS systems technologies, double conversion and flywheel UPSs. To clear most concerns about selecting the right UPS system for the right site. Then educated decision can be made when the different two types of UPSs topologies are properly identified.
- The ROMONET computer software program is used to offer a predictive modelling tool for the data centre in order to evaluate how it would operate under different conditions.
- Deploy the double conversion static UPS technology in medium size data centre based on 2N configuration and calculate the system efficiency, UPS efficiency, Power Usage Effectiveness (PUE), UPS and the system cost.

- Deploy the flywheel UPS technology in medium size data centre based on 2N configuration and calculate the system efficiency, UPS efficiency, Power Usage Effectiveness (PUE), UPS and the system cost.
- Deploy the double conversion static UPS technology in medium size data centre based on N+1 configuration and calculate the system efficiency, UPS efficiency, Power Usage Effectiveness (PUE), UPS and the system cost.
- Deploy the flywheel UPS technology in medium size data centre based on N+1 configuration and calculate the system efficiency, UPS efficiency, Power Usage Effectiveness, and UPS system cost.
- Finally, power usage effectiveness and system cost are a detailed comparative analysis of the different systems mentioned in this work. And a lifecycle period of five years is envisaged from the initial capital investment, incorporating all maintenance, together with the operational costs.

1.3 Research Contribution

As data centres, manufacturing and other facilities look to increase power quality and reliability, they are faced with a choice of UPS systems. There are two common types of UPS units that are seen in the market today. Double conversion static UPS system, and flywheel UPS system

[128]. Some researchers believe that, the double conversion, UPS provide top quality protection for even your most mission-critical equipment, and has the capability to operate in the Eco mode to provide a high performance and constitute a significant contribution to high efficiency [54, 63].

However, there has been a steady growth in the flywheel energy storage market as technology has improved. A flywheel is essentially a rotating mass that spins at incredible revolutions per minute (RPM). This spinning disc is typically housed in vacuum to reduce resistance and is used to convert kinetic energy to produce DC power. This can provide both power conditioning and runtime in the event of a power outage [68]. Conversely, a battery UPS system stores energy and converts it to electrical power through a chemical reaction. Both

systems condition power and provide reliable backup in the event of a utility failure. Here are a few considerations when comparing the two main types of units [69].

In theory, a flywheel UPS system requires significantly less space than a double conversion UPS. Since they do not have large battery requirements, the overall weight of the UPS is substantially less than a battery UPS. Active Power, a leading manufacturer of flywheel systems, states that the average flywheel UPS configuration should consume 75% less space compared to a conventional double conversion, battery UPS system [75].

In order to clear that concerns. A series studies, simulations and calculations will be undertaken to determine which UPS technology and topology can improve data centre energy efficiency and reduce the cost.

The contributions to knowledge of this study can be highlighted from different dimensions including the following:

- This study is the first to investigate and compare the double conversion static UPS technology and flywheel UPS technology, in an electrical model for a medium size data centre is designed to provide 1500 kW to IT load based on 2N and N+1 configuration. It contributes by providing data centre owners and operators with a clearer understanding of key factors and considerations involved in selecting the right UPS to meet present and future requirements.
- This study reveals, that flywheel UPS systems, provide dramatically better efficiency across the board than conventional double-conversion UPS with batteries, based mainly on the two-step process of converting utility power from AC to DC, and then from DC to AC. This higher efficiency meets the quality power target.
- The results illustrate that the flywheel technology achieves the lower PUE across all levels of electrical loading. The optimal PUE achieved in '2N' architecture was by the flywheel system operating at maximum load, achieving a PUE of 1.23.
- This study reveals, that the cost of flywheel UPS systems, at difference loads from 25% to 100%. Is less than the double conversion static UPS. based on 2N and N+1 configuration.
- This study reveals, that the double conversion static UPS and flywheel UPS technology run in an N+1 configuration is more efficient at 100% load, whereas at the same load in 2N configuration. And that because of the additional losses experienced in the 2N topology.

1.4 Thesis Outline

The study comprises seven chapters. Figure 1.2 illustrates the structure of the thesis.

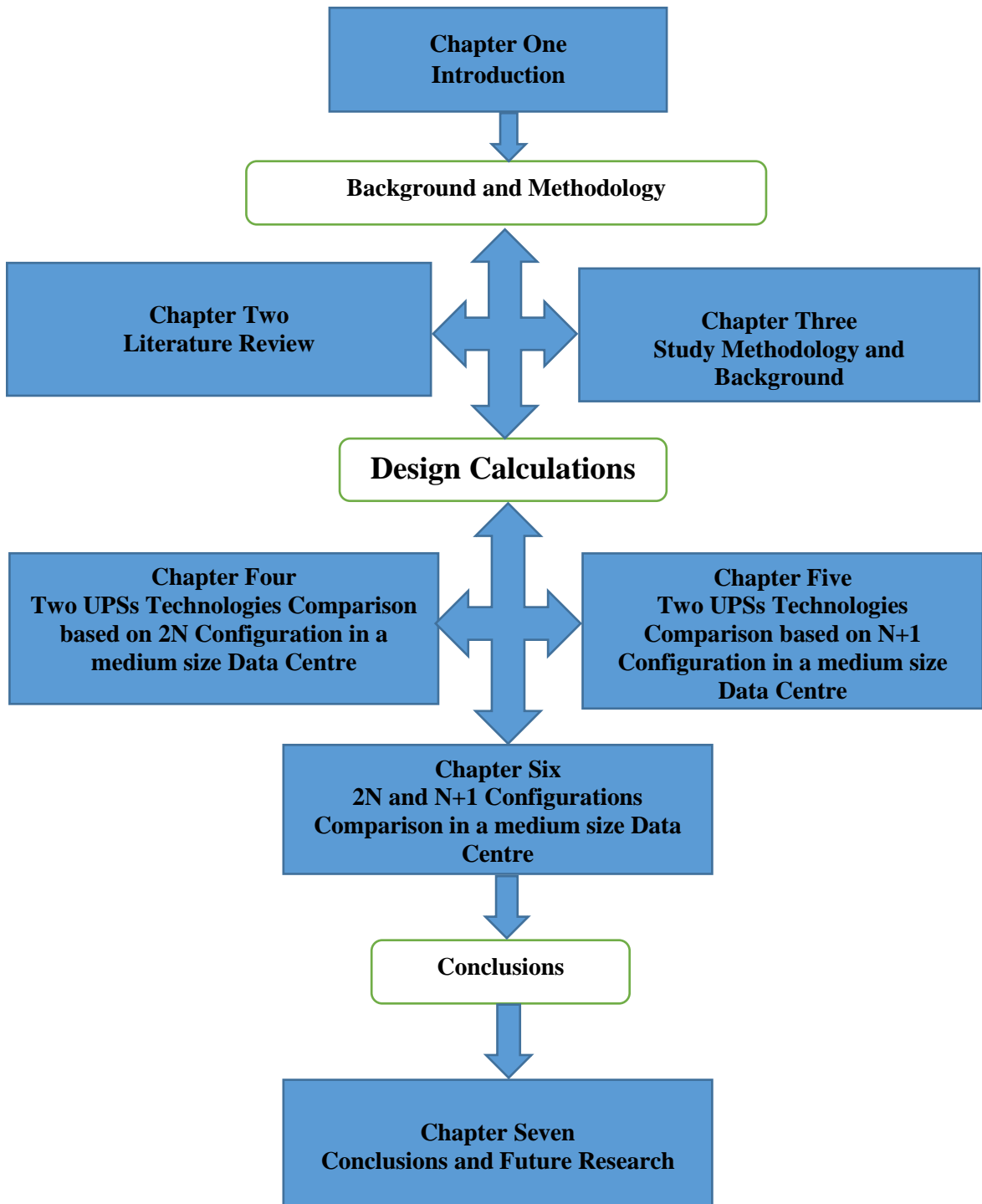

Figure 1.2: Thesis Outline

Chapter 2: LITERATURE REVIEW

In this chapter, a brief overview is given about data centre power system, uninterruptible power supply (UPS) system, and data centre availability classifications system.

2.1 Data centre background

Data centre are physical facilities that mainly contains electronic equipment used for Data processing (servers), data storage (storage equipment), and communications (network equipment). All that electronic equipment stores transmits digital information and equipment processes is known as “information technology” (IT) equipment. Data centre also usually contain specialized power conversion and backup equipment to prevent the IT equipment from experiencing power disruptions, which could cause serious business disruption or data loss and leading to maintaining reliable, high-quality power, as well as, environmental control equipment to maintain the proper temperature and humidity for the IT equipment [1,12].

Data centre range vastly in size, from small rooms to custom warehouse buildings. Firstly, at the range of small side, the data centre typically includes only a few computers without any special infrastructure for cooling or power delivery. It could find these small data centre at small business or universities. Secondly, the middle range of the data centre typically comprises a server, communication, and storage hardware (rack-mounted server). That mean a computer dedicated to using as a server and designed to be installed in a framework called a rack. The rack contains multiple mounting slots called bays, each designed to hold a hardware unit secured in place with screws [2, 3] and organized into rows as shown in Figure 2.1. The rows form aisles for either hot or cold air. These data centre include significant cooling and power delivery infrastructures. It could find these medium data centre at larger business or Servers facilities which a company owns it, and other companies use as their internet servers all in one place [21, 23].

Finally, the large rang of data centre which consists of many thousands of servers with extensive communication and storage infrastructures. They also include massive cooling and power delivery infrastructures. These data centres typically run large Internet services, such as Google, Microsoft, Yahoo, and Amazon [17, 18]. Because of their enormous scale, these data centre consume enormous amounts of electricity as much as standard office spaces, which are driving to a significant increase in energy inefficiency problems in data centre. And that lead to high operational costs. Also the massive amounts of computation power contained in these

systems results in many interesting distributed systems and resource management problems [19,20].



Figure 2.1: Core site data centre [3].

As stated by Choa, Limb, and Kimb, the source side systems consist of UPSs, power distribution, cooling, lighting and building switchgear account for almost 48% of total consumption. Whereas, demand side systems which contain processors, server power supplies, storage and communication equipment, account for 52% of total consumption. In the UK, nearly 30000000 kWh of power might be consumed in a year by a large data centre, costing its operator around £3,000,000 for electricity, some of the UK sites consume more than this. Energy is generally the largest single component of operating costs [22], for data centres, varying from 25-60% of total costs. So, any ideal data centre shall plan to reduce power consumption while maintaining a low failure rate [14, 16].

2.2 Data centre availability classification system and standard

The data centre industry has created a four-tier classification and standard system, in order to consistently describe the site level infrastructure within the facility. This system was created by Uptime Institute and has been adopted as the industry standard. The individual tiers represent categories of site infrastructure topology that address increasingly sophisticated operating concepts, leading to increased site infrastructure availability [29]. The power capacity for each tier that can be carried by the power distribution units (PDUs) for each tier. are depends on the rating of the facility input plug. If the actual load exceeds the rating on the input plug for a sufficient period of time, the input breaker will trip, and power will be interrupted to everything that receives power from that plug [30].

A data centre also has an IT load power capacity and a cooling capacity (which ideally should be the same), and it has an IT space capacity (cabinets or square feet). The ratio of the watt capacity to the space is the design density [31]. So, the basic data centre power metrics have been used for the design and calculating the power density are:

- Power/area (W/ ft²) = power density for the data centre but not reflect the sizing of specific cooling or power architecture. The layout of computer room – the density of IT racks – is a determinant factor.
- Power/rack (kW/rack) = power density metric reflects the distribution of equipment on surface.

Table 2.1: Summarized the four tier level definition for data centre [31].

Facility Characteristics	Tier I	Tier II	Tier III	Tier IV
Number of Delivery Paths	1	1	1 active, 1 Alternate	2 Active
Redundant Components	N	N + 1	N + 1 and 2N	(2N)
Concurrently maintainable	No	No	Yes	Yes
Fault Tolerance	No	No	No	Yes
UPS / generator	optional	Yes	Yes	Dual
Compartmentalization	No	No	No	Yes
Continuous Cooling	Load Density Dependent	Load Density Dependent	Load Density Dependent	Class A
Utility voltage	208V-480 V	208V-480 V	12-15 kV	12-15 kV
Availability	99.671%	99.741%	99.982%	99.995%

2.2.1 Tier I data centre

Tier I data centres are appropriate for small businesses using IT primarily for internal purposes. It provides an improved environment over that of an ordinary office setting and includes a dedicated space for IT systems, and have a single non-redundant power and cooling distribution path serving the IT equipment, and twelve hours of on-site fuel storage for engine generator. This results in a typical availability level of 99.671% [30, 31]. The operational impact of this type, any unplanned outage or failure in the system will affect the computer equipment [32].

2.2.2 Tier II data centre

Tier II data centres are redundant Component data centres, like Tier I data centres, they have a single path for power and cooling distribution and add redundancy, using equipment such as UPS modules, chillers or pumps, and engine generators which protect it from interruptions in IT processes. The primary difference between a Tier I and Tier II classification is the presence of an additional generator and UPS. All other components of the system are basically the same. Even with this redundancy there are still several different single points of failures in the path to deliver power to the IT load. This resulting improves the availability to approximately 99.741% [33]. The operational impact of this type, any unplanned outage or failure in the system will affect the computer equipment [34].

2.2.3 Tier III data centre

Tier III is referred to as an active-passive system. In a Tier III classification the power delivery path must be doubled. Besides the redundant critical components there has to be a second path parallel to the critical IT load in case the primary path has failed. This second path could be passive used only in case of emergency [32]. A Tier III classification also requires a second utility connection. The addition of the passive delivery path significantly raises the cost of the entire system and complicates the control, coordination, maintenance, etc. There is also an additional switchgear and motor control centre (MCC), which should allow the full operation of the data centre from the passive path. The IT equipment can now take full advantage of the dual supply paths and therefore utilize dual PSUs for each server, for example. Thus, the number of single points of failure is significantly reduced. However, the passive delivery path does not require UPS so during the emergency conditions the system is vulnerable to utility conditions, therefore potentially exposed to utility power quality issues or even power outages. This resulting improves the availability to approximately 99.982% [34]. (see Figure 2.2).

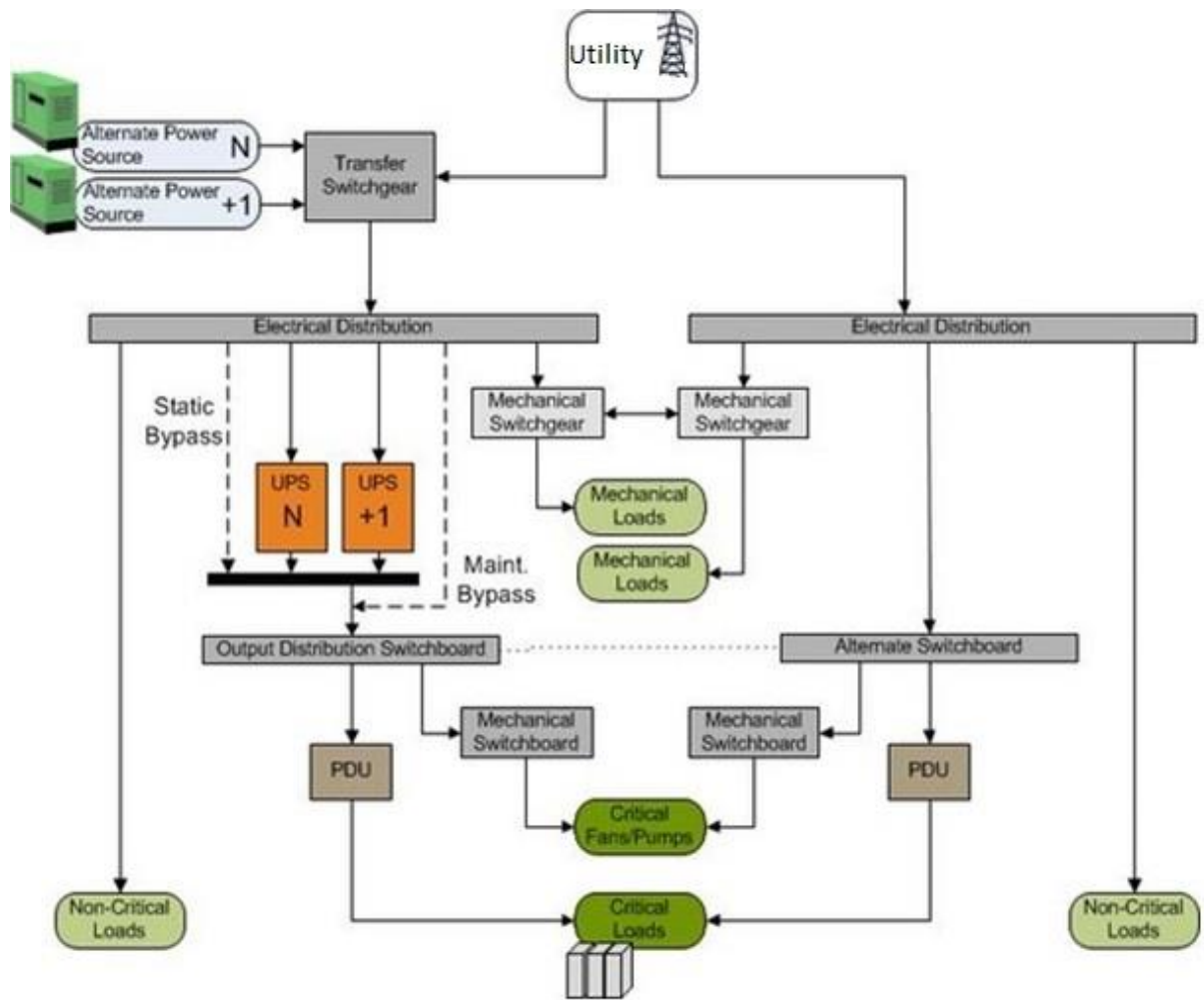

Figure 2.2: Infrastructure Tier III classification [42]

2.2.4 Tier IV data centre

Referred to as a 2N or 2N+1 system, the Tier IV classification is also considered as most robust and less prone to failures. A relatively small number of data centres in the world are certified as Tier IV designs. They are fully redundant, complete dual systems running actively in parallel [40, 41]. The distribution path and complementary system must be separated and isolated, to prevent any single event from affecting both systems [42] (see Figure 2.3). By advantage of the redundancy the rating of each path should be 100 percent of the load and therefore the maximum utilization of the two paths under normal operating conditions is at maximum 50 percent. In addition, some Tier IV designs will have N+1 of UPSs and backup generators in each path, further increasing the complexity and cost but at the same time gaining the valuable fraction of a percent (0.01 percent to be exact) for availability. The target for Tier IV availability is to allow a maximum of 24 min per year of the annual site-caused end-user downtime (representing one failure every five years). The availability of Tier IV is approximately 99.982% [43, 44].

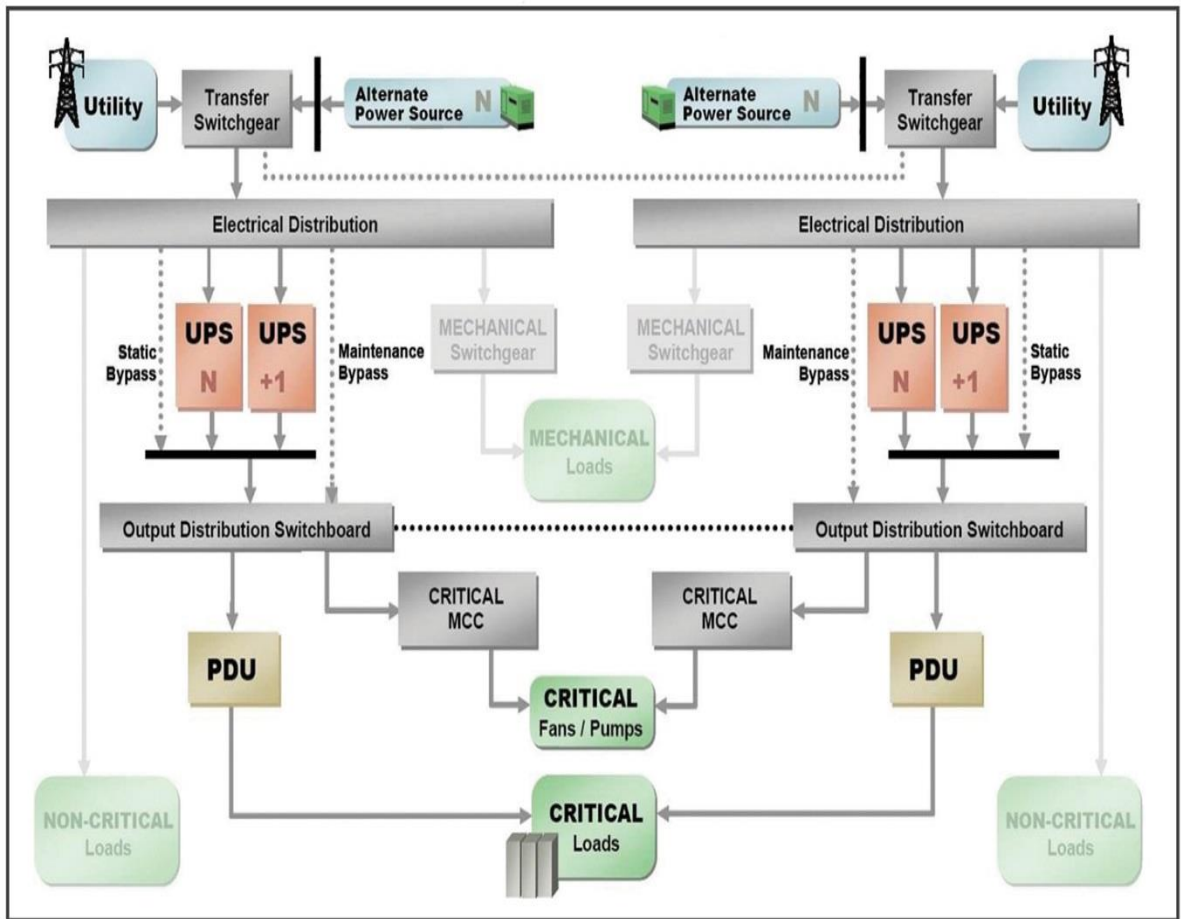

Figure 2.3: Infrastructure Tier IV classification [42]

2.3 Data centre power system

From an electrical design standpoint, a data centre is a hierarchy of electrical devices that transmit power from a utility feed to server racks [45]. One or more feeds arrive from the electrical utility before or after their voltages are transformed to usable levels. Switchgear provides, among other things, a disconnect point for the utility feed where needed [46]. The Standby Power system will operate either from stored power usually within lead acid batteries installed within the UPS or by generated power from a generator [47]. The (UPS) systems can provide power up to several minutes to allow a secure shutdown or the continuity of operation depend on the USP type, on the other hand, a standby power system is needed for longer outages to protect from the loss of power [47,48].

Typically, the utility supplies a medium voltage (MV) service to a dedicated data centre. Then the MV is stepped down to low voltage (LV) by a MV/LV transformer located in the data centre. LV power is distributed to the different electrical loads such as IT devices inside the racks, cooling system, lighting, etc. by the electrical distribution equipment. For example, the

voltage from the UPS goes to the power distribution unit (PDU), which contains a transformer that steps the voltage down to 120/208 VAC. Then inside the server a power supply unit (PSU) converts the 120/208 VAC to direct current (DC), from which a voltage regulator module (VRM) shifts the voltage down to the end load [50, 51].

2.4 Uninterruptible power supplies design and topology

The UPS provides backup power when utility power fails, either long enough for critical equipment to shut down gracefully so that no data is lost, or long enough to keep required loads operational until a generator comes online [47]. The UPS system is a backup source of power, installed between the mains power supply and the critical end loads [48], to provide two functions. First, it provides a secure power source when the main AC power supply fails, then supported the load while the power source shifts from utility to a standby generator. Second, it provides a clean, stable and regulated supply when the mains supply is present. An ideal UPS should be able to deliver uninterrupted power, at the same time providing the necessary power conditioning for critical loads [51, 50]. For these reasons, electric utility companies considered UPS to be the primary source of standby power protection. UPS systems can provide power for up to several minutes. However, a standby power system is needed for longer outages [48, 54].

Even a momentarily loss of power can cause IT systems and sensitive equipment to crash and lose data in a data centre. A UPS maintains power by switching instantaneously to batteries in the event of utility power failure; they also condition the power supply to reduce unwanted spikes and harmonics [52, 53]. Different types of UPS have been designed to correct a variety of power problems, such as:

- Power failure: the total loss of power.
- Sags: transient under voltage.
- Brownouts: under voltage for a period of time (milliseconds to days).
- Spikes: very brief, but high energy bursts (lasting only a few milliseconds). Spikes are typically caused by lightning or malfunctions in the power supply and can damage sensitive solid-state components and destroy data in digital equipment.
- Surges: relatively short duration (from milliseconds to seconds) of high voltage power surges.
- Line noise: distortions superimposed on the power waveform which are caused by electromagnetic interference.

- Frequency variation: deviation from the nominal frequency, which causes motors to increase or decrease speed.
- Switching transient: instantaneous under voltage, which may cause erratic behaviour in some equipment resulting in memory loss, data error and loss, and component stress.
- Harmonic distortion: multiples of power frequency superimposed on the power waveform, which causes excess heating in wiring and fuses.

UPS technology comes in two types; static or rotary UPS. However, each of those classifications contains several types of technology and significant differences in what the technology provides. The main UPS systems deployed in data centre applications are either double conversion static UPS systems or Flywheel Rotary UPS systems [54, 118]. The following sections discuss strengths and weaknesses of the two types, in order that the optimum topology can be selected for the appropriate job.

2.4.1 Rectifiers

A rectifier is an electrical device composed of one or more diodes that converts AC from the mains or another AC source to DC (see Figure 2.4). This process is called rectification. The rectifier can generate a high level of harmonic supply, dependent on their design, UPS type used and the method of operation [1, 55].

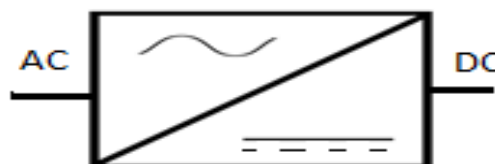

Figure 2.4: A typical rectifier symbol

The rectifier can generate a high level of harmonic, dependent on their design, UPS type used within and method of operation. Typically, some UPS used Silicon Controlled Rectifier (SCR) to do the rectification conversion. However, now a day's many UPS use insulated gate bipolar transistors (IGBT) transistors in place of (SCR) to create an almost perfect sine wave [55].

2.4.2 Inverter

A power inverter is a device that creates an AC waveform for the connected load equipment of a DC form using electronic circuits. In this work the double conversion static UPS

technology used (IGBT) which are used with an inverter output filter to create an almost perfect sine wave output [1,55] (see Figure 2.5).

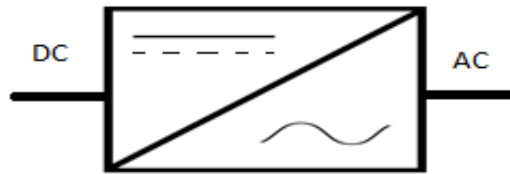

Figure 2.5: A typical inverter symbol

Inverter designs vary greatly based on the type of system, typically based on the criticality of the system and its cost [1].

2.4.3 Battery sets

The main job for the batteries sets in UPS is providing DC supply when the main power supply failure to the inverter. Then the inverter creates an AC power to connect the load [1, 56]



Figure 2.6: Battery set symbol

As reported by Bentley and Bond, [1], the amount of time that the inverter will be able to support connected equipment from battery sets is known as back up time or runtime. Most battery sets in the market typically provide from five to 30 minutes, depending on the data centre power load. The back-up time can be increased by adding external battery packs to a UPS that accepts them. Therefore, it is important to know how long the equipment will continue running by the UPS until the standby generators can supply the power to the designated loads.

2.4.4 Static bypasses switch

The main job of the static bypasses switch ensures the load drops automatically onto the mains input feed. Static Bypass switches are used to bypass the UPS normal operation, in cases of high inrush or fault conditions. Manual bypass switches are an added benefit to allow service and isolation for safety purposes [58]. The IT Load connected and powered by the

inverter through the static switch, in the case of power supplied by UPS becomes insufficient, the static switch automatically transfers the load to bypass supply, and then the automatic bypass supply mode path transfers the load to the alternative bypass power path. This provides the UPS with a level of resilience in case of power supplied by the inverter becomes insufficient. When the fault is cleared, the load transferred back to inverter output automatically by the bypass. Therefore, a static switch provides extra resilience to the UPS by providing a safe failure to the main facility. Most modules now use straight static switches with a mechanical switch in parallel [1, 59] (See Figure 2.7).

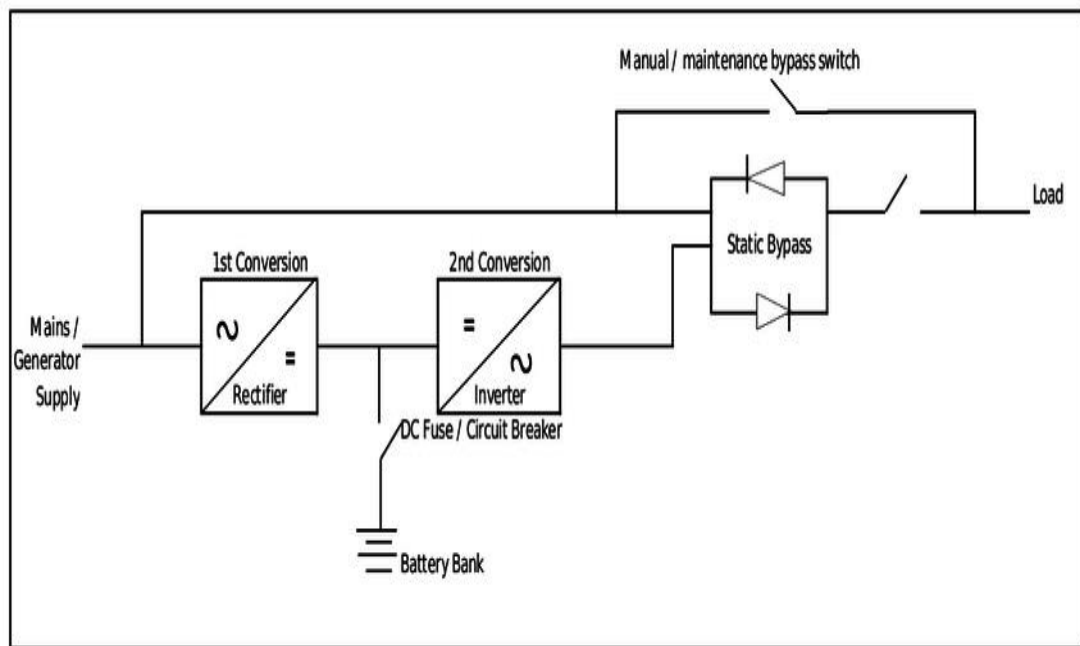

Figure 2.7: Static switch in online UPS double conversion type [59]

The uninterruptible power supply system can be operating in bypass by a static switch (see Figure 2.8) for the following reasons [60, 61].

- Any fault occurred within a critical part of the UPS.
- The load exceeded the maximum rating of the system; then the static switch automatically transfers the load to bypass supply to protect the inverter.
- When the UPS manually transferred to bypass for maintenance, so they can do the maintenance within the UPS safely without disrupting power to the load

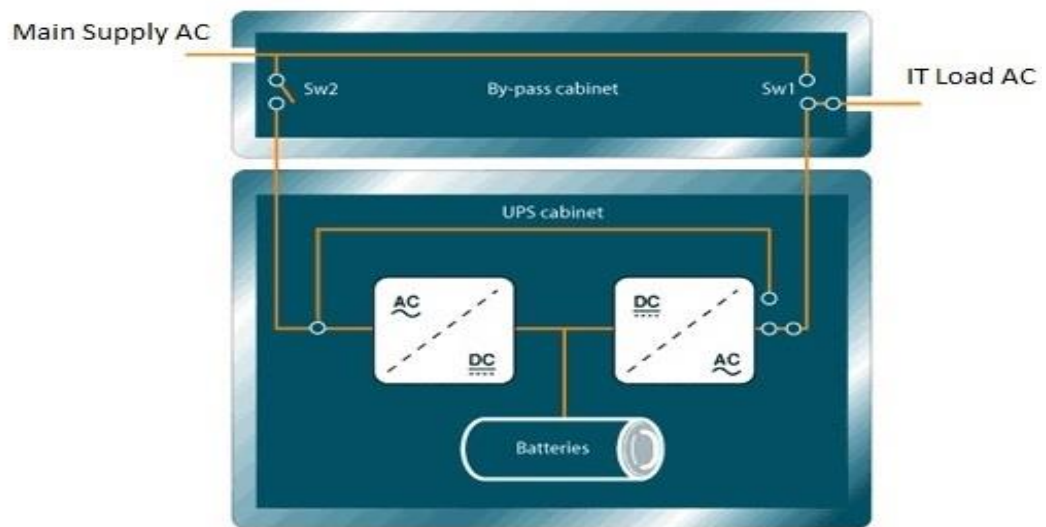

Figure 2.8: Static switch for bypass mode [59]

2.5 Double conversion static UPS type

EN/IEC 622040-3 classifies three static UPS according to their abilities to perform and provide power protection ranging from low power devices such as PCs to high-power megawatts facilities such as a large data centre. Furthermore, UPSs come in many voltage ratings, both single- and three-phase. Low powers units are essentially single-phase, while medium- and high-power units are generally three-phase [1, 60]. The three static types specified by IEC standard 62040-3 are.

- Passive Standby or off Line UPS (IEC 62040-3.2.20)
- Line Interactive (IEC 62040-3.2.18)
- Online UPS [Double Conversion UPS] (IEC 62040-3.2.16)

Off Line and Line Interactive UPSs are limited by their design to small devices such as PCs or small office systems. In contrast, Online UPS (or Double Conversion UPS) systems provide greater electrical performance and reliability. They are designed for high-power megawatts facilities and can be found in industrial manufacturing sites and data centres. This section takes a closer look at double conversion UPSs [61]

The basic double conversion UPS system or an Online UPS consists of four basic elements, as shown in Figure 2.9. Firstly, a rectifier-charger, which converts input AC power to DC power, then an inverter, which converts DC power to AC power for the critical load. That is why known as double conversion because of its two voltage conversion stages, then a battery,

which stores energy during the availability of normal supply and provides DC power to the inverter in the event of input AC failure. Finally, static bypass switch, which transfers the critical load to the bypass source in the event of a failure in some of the elements [62].

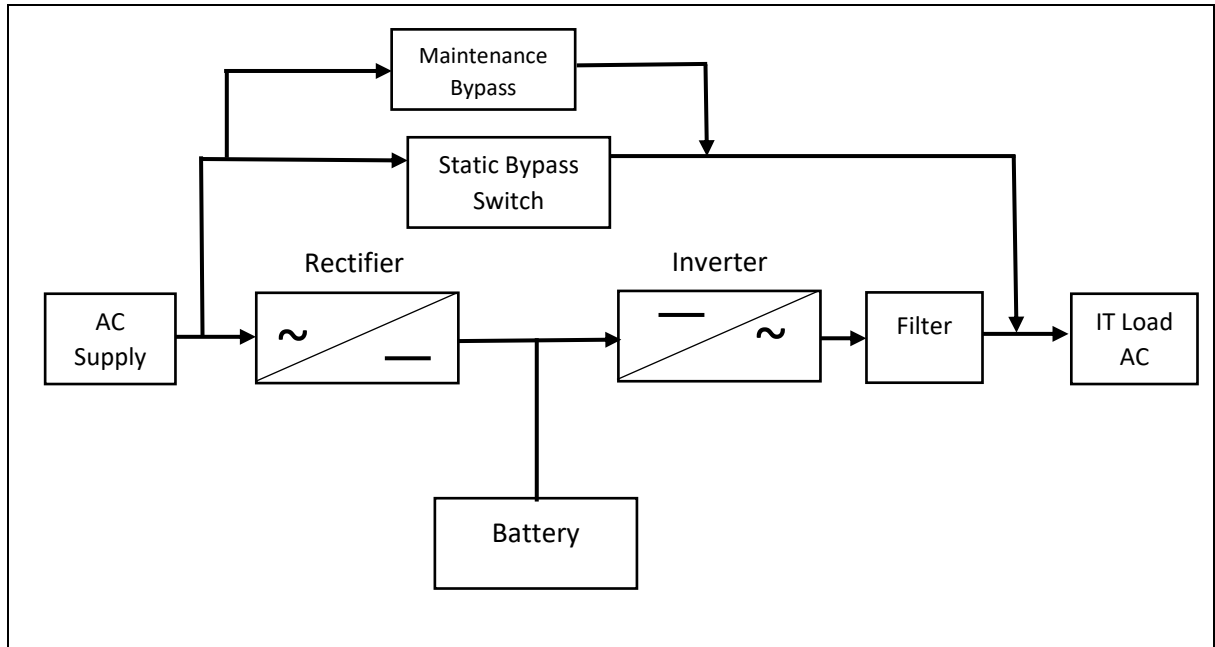

Figure 2.9: Double conversion static UPS system

As stated by Bentley and Bond, et al, [1], some advantages of this configuration listed below.

- The IT critical load is completely isolated from the incoming main AC input power.
- The performance levels are higher under steady-state and transient conditions.
- An immediate change to the battery backup mode if utility power fails.
- A no-break transfer to a bypass line (bypass mode).
- A manual bypass (generally standard) to facilitate maintenance within the UPS safely without disrupting power to the load.

2.6 Uninterruptible power supply operating modes in double conversion

The inverter is connected in series between the AC input and the application.

2.6.1 Normal mode

During normal operation, all the power supplied to the load passes through the rectifier which converts input AC power to DC power. The inverter converts DC power to AC power for the critical load. The conversion from AC to DC and back is the reason why the system is known

as double conversion. It is the only UPS system that provides the load with continuously processed and backed-up power [63].

2.6.2 Stored or battery backup mode

When the AC input main fails, the rectifier will shut down, at which stage the battery, without interruption using a static switch, provides an alternative DC power source for the inverter via the DC converter. The UPS continues to operate on battery power until the end of battery backup time or utility power returns to normal mode [64].

2.6.3 Bypass mode

In this bypass mode, the critical load is supported directly by utility power through the UPS bypass, sometimes referred to as a static switch, in the event of the following.

- UPS failure (A fault within a critical section of the UPS)
- The load exceeds the maximum rating of the system, at which stage the static switch automatically transfers the load to the bypass supply to protect the inverter.
- When the UPS is manually transferred to bypass in order to undertake maintenance safely without disrupting power to the load

However, the output of the bypass mode is not protected from voltage or power outages from the main source. Also, the UPS must be synchronized with the bypass power to ensure load supply continuity. Figure 2.10 shows the operating modes of double conversion static UPS system [65].

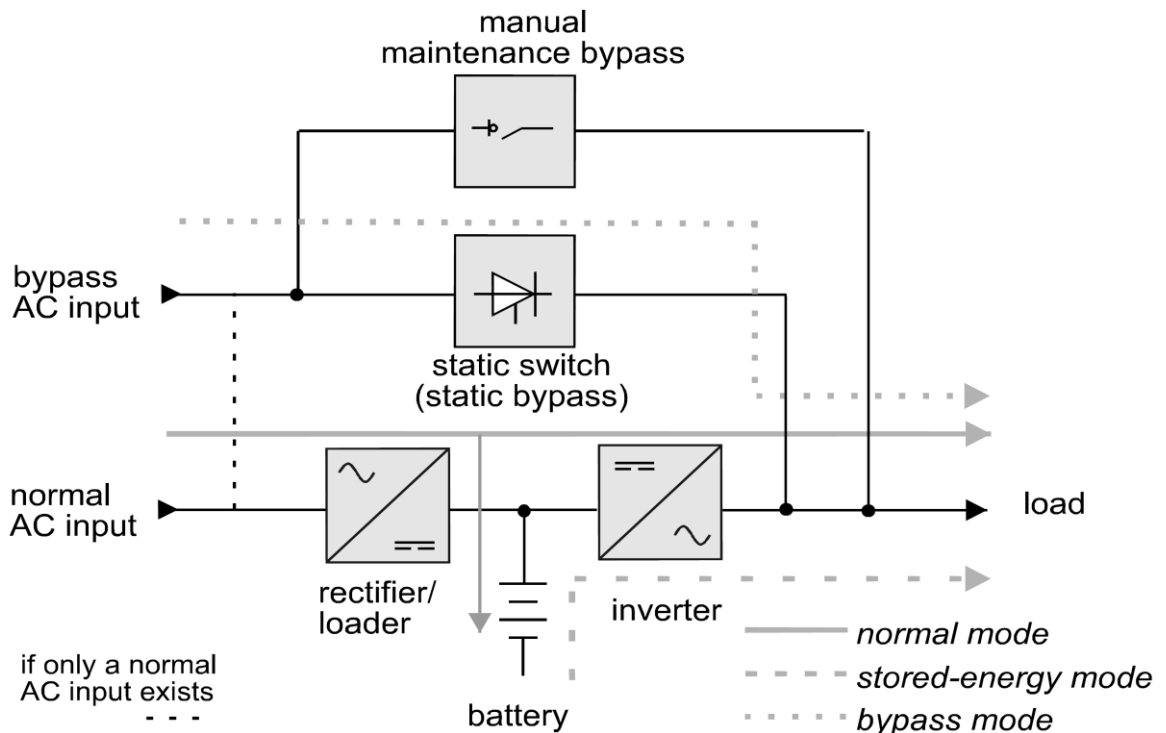

Figure 2.10: Double conversion static UPS system operating modes [65]

2.6.4 Operating the Double conversion UPS in ECO mode

Eco-mode is an economy mode of operation, help the double conversion UPS achieving the highest possible efficiencies. The reasons for using ECO method of operating to obtain improved the UPS efficiencies by 2% to 4%, and reduce the operating expenses experienced in the data centre [63, 65].

The typical normal double conversion UPS mode, takes the incoming utility power and passes it through a rectifier-charger, which converts input AC power to DC power, then an inverter, which converts DC power to AC power for the critical load. During a utility interruption, these batteries which stores energy during the availability of normal supply, then provides DC power to the inverter. Finally, static bypass switch, which transfers the critical load to the bypass source in the event of a failure in some of the elements. This bypass system can also isolate the UPS from the critical loads in the event of a UPS failure [115,117].

UPS systems with an ECO mode use the same configuration as double conversion units, but with different operational characteristics that provide an increase in efficiency. When placed in eco mode, the UPS system typically allows utility power to bypass the rectifier and inverter and directly feed the critical load. In the event of a power disturbance, the UPS can provide conditioned power to the load by returning to normal mode [63, 114]

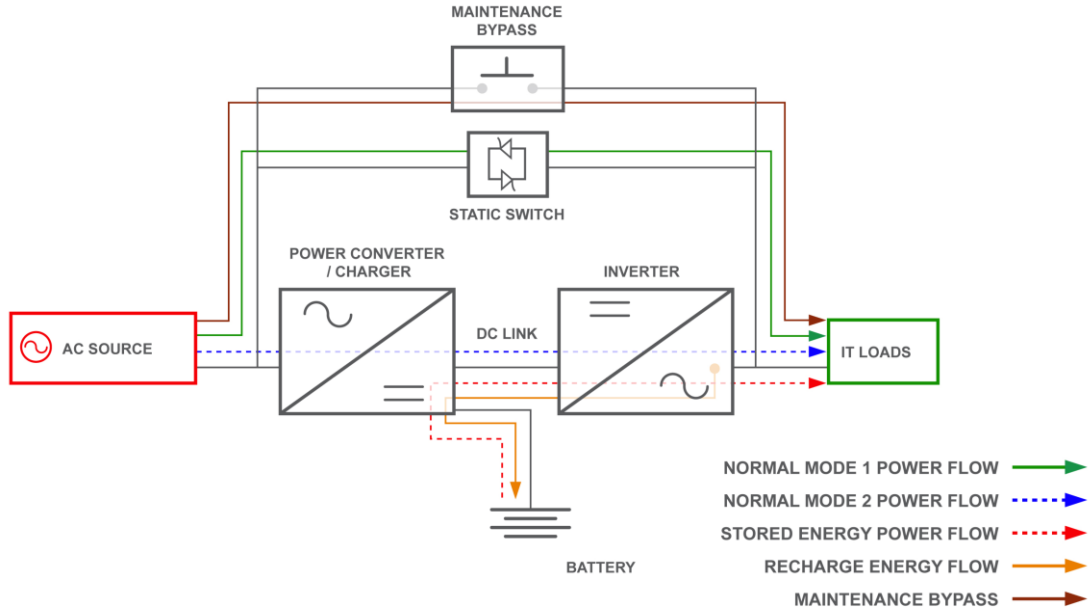

Figure 2.11: Double conversion UPS in multi operation modes [2]

2.7 Flywheel energy storage system UPS

The flywheel energy storage system (FESS) UPS, is referred to as rotary because rotating components (such as a motor-generator) within the UPS are used to transfer power to the load. A FESS is composed of a rotor, bearing system, driving motor and housing (see Figure 2.12). For high power, it is a mechanical battery simply converting and storing electrical energy into kinetic energy. The stored energy is used in the form of electrical power when it is required during a utility outage, and the amount of energy stored is proportional to the flywheel's mass and to the square of its rotational speed [67, 68].

$$E = \frac{1}{2} \times MV^2 \quad (2.1)$$

As maintained by IEC Standard 62040-3, storage energy (E) is related to the inertia of the flywheel derived from its mass (m) and the square of its rotational speed (v) (see Formula 2.1). The equation demonstrates how the storage energy is related to the speed of the rotor which if it exceeds the speed limit, will put extra strain on bearings. To expand the mass of the rotor would have a similar effect putting extra strain on the bearing system [69].

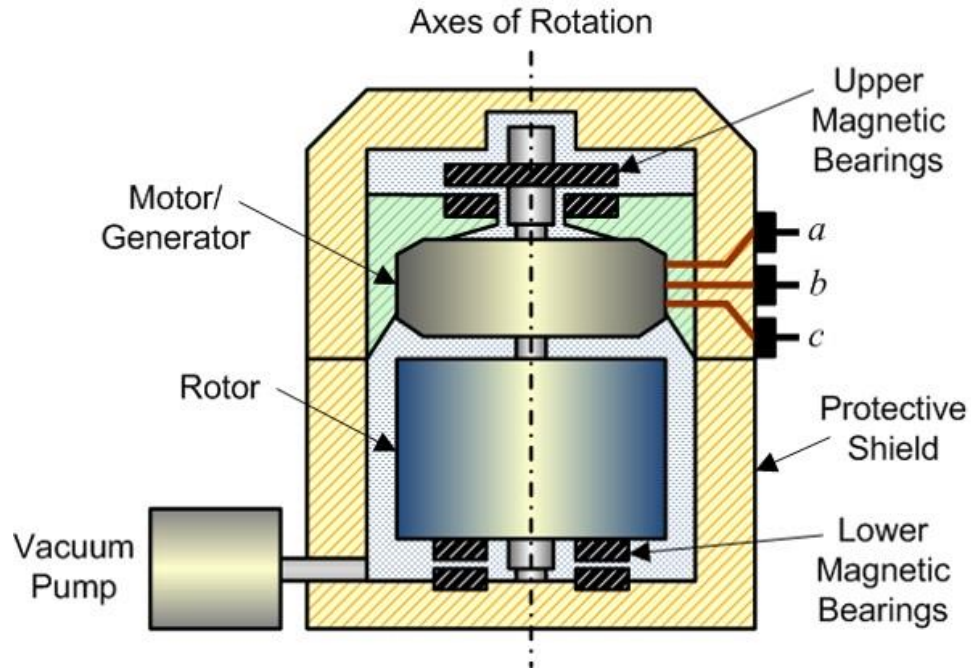

Figure 2.12: Structure of a conventional flywheel [68]

As Figure 2.12 illustrate, the flywheel energy storage system (FESS) is mainly composed of a rotor, bearing system, driving motor and housing [70, 116]. The flywheel has been used in the quality power industries for the last few decades in rotary UPS and as a replacement for batteries. Traditionally, flywheels were used only as high power energy-storage devices for ride-through applications with duration of several seconds [72, 112]. However, nowadays, there are flywheels on the market that can provide energy in the kWh range and now a day, a percentage of data centre operators opposed to the traditional static UPS system with its requirement of large battery capacity have embraced flywheel technology. The flywheel technology performs as a ‘mechanical battery’ simply converting and storing electrical energy in kinetic energy [73, 74].

The power grid provides energy through two power electronic converters to the critical load; the AC-DC rectifier and the DC-AC inverter. The FESS is attached into the UPS system through the DC link between two converters. In this way, DC bus voltage is firmly controlled by the FESS [75, 112] (see Figure 2.13).

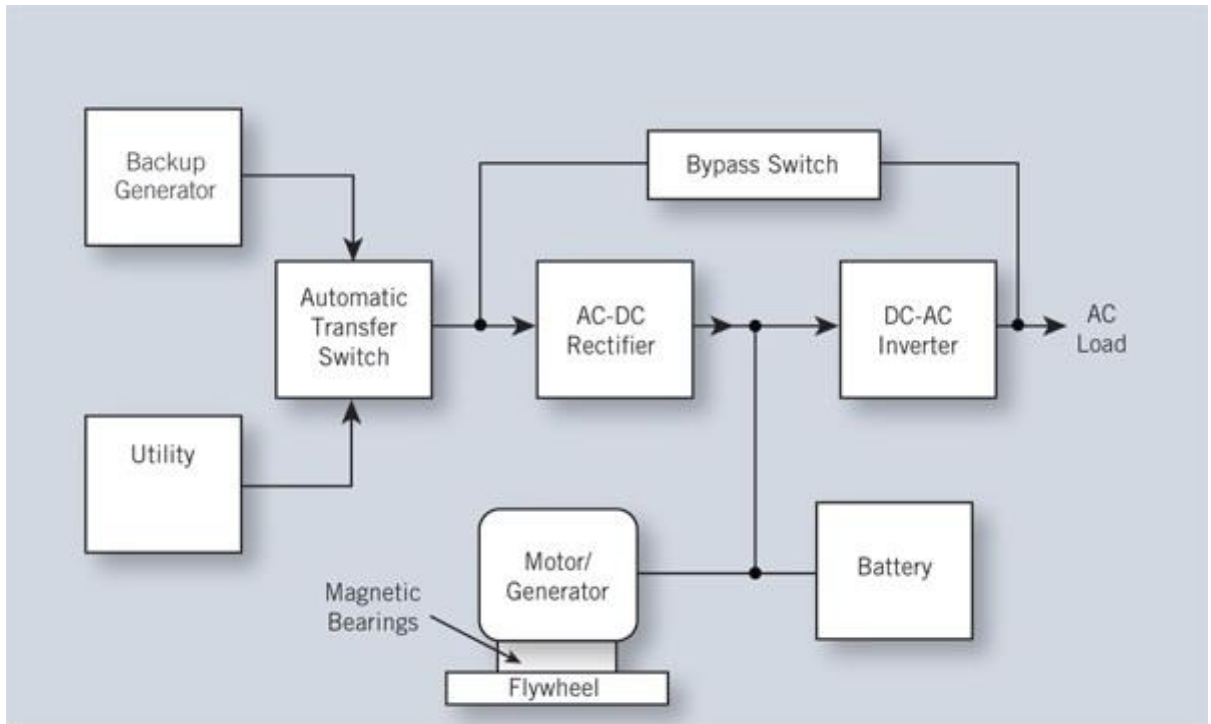

Figure 2.13: Flywheel energy storage system in UPS [75]

A flywheel energy storage system (FESS) is mainly composed of rotor, bearing system, driving motor and housing. The power grid provides energy through two power electronic converters to the critical load. They perform as rectifier AC/DC then to inverter DC/AC respectively. The flywheel energy storage system is attached to the UPS system through the DC link between two converters. In this way, DC bus voltage is firmly controlled by flywheel energy storage system [74].

Flywheel energy storage systems have three operation conditions, charge, discharge and stand-by. In the charging mode, power grid provides energy into the flywheel through AC/DC rectifier then to inverter DC/AC [111]. At the point when flywheel quickens to the appraised speed, the flywheel energy storage system moves into the stand-by mode. Finally, if a power outage happens, flywheel energy storage system switches into discharge mode, the “Interior Permanent Magnet Synchronous Motor” works as a generator to provide energy to critical load through AC/DC rectifier then to inverter DC/AC. When power grid recovers from the breakdown, the flywheel energy storage system returns the charge mode [74, 119].

2.8 Cost comparison

Another important aspect in the choice of an energy storage device is its costs. By means of calculations it is easy to verify that, taken over the year, a flywheel storage device is more economical than a double conversion UPS solution. The main reasons for this are the low maintenance costs and the long service life of the flywheel compared to the double conversion UPS type, which more than balances out the higher acquisition costs at the start of installation. Whereas a flywheel storage device usually has the same service life as the UPS system, double conversion battery installations must be replaced several times during the service life of a UPS [119]. The discontinuities of the costs can be seen in next chapters.

2.9 Uninterruptible power supply configurations types

As mentioned above, this dissertation is designed to provide data centre managers and operators with a clearer understanding of the key factors and considerations involved in selecting the optimal UPS system. And how future UPS system topology and technology can improve the data centre in terms of efficiency and cost. To achieve the research, aim. A model of a medium size data centre was designed to provide 1500 kW to support the IT load. The electrical infrastructure topology adopted is configured to '2N' and 'N+1' redundancy configuration for each of the two UPS systems. The results are plotted and analysed. Next, 'N+1' and '2N' Redundancy Configuration architecture, how they work and what 'N' stands for is discussed.

2.9.1 What does 'N' standing for and mean?

By means of the Letter "N" when designing UPS configurations can simply be defined as the number of UPS modules that are required to supply power to IT load. In other words, the minimum backup protection required feeding the critical load [76].

The N System Configuration mean, one or more UPS modules work together to supply power to the IT load. Each UPS System with an N configuration can have multiple UPS Groups, where each group is connected to a different load. And all UPS Modules must have the same Rating value (kW). This type of system is by far the most common of the configurations in the UPS industry [76].

2.9.2 Capacity 'N' system configuration

The N System Configuration is a common configuration system in the UPS industry. In normal operational mode, the critical load is supplied by the inverter, but in the event of the UPS is offline or taken out of service for maintenance, then the UPS is changed to bypass

mode and the load is served through the bypass line [77], (see Figure 2.14). Thus, the critical load is directly supported by utility power. This configuration offers less redundancy, and, therefore, limits the load protection. Also, all the UPS Modules must have the same Rating value (kW) [76]. The capacity (N) configuration is the minimum requirement to provide protection for the load, also offer less redundancy and availability values compared to all other configurations [77].

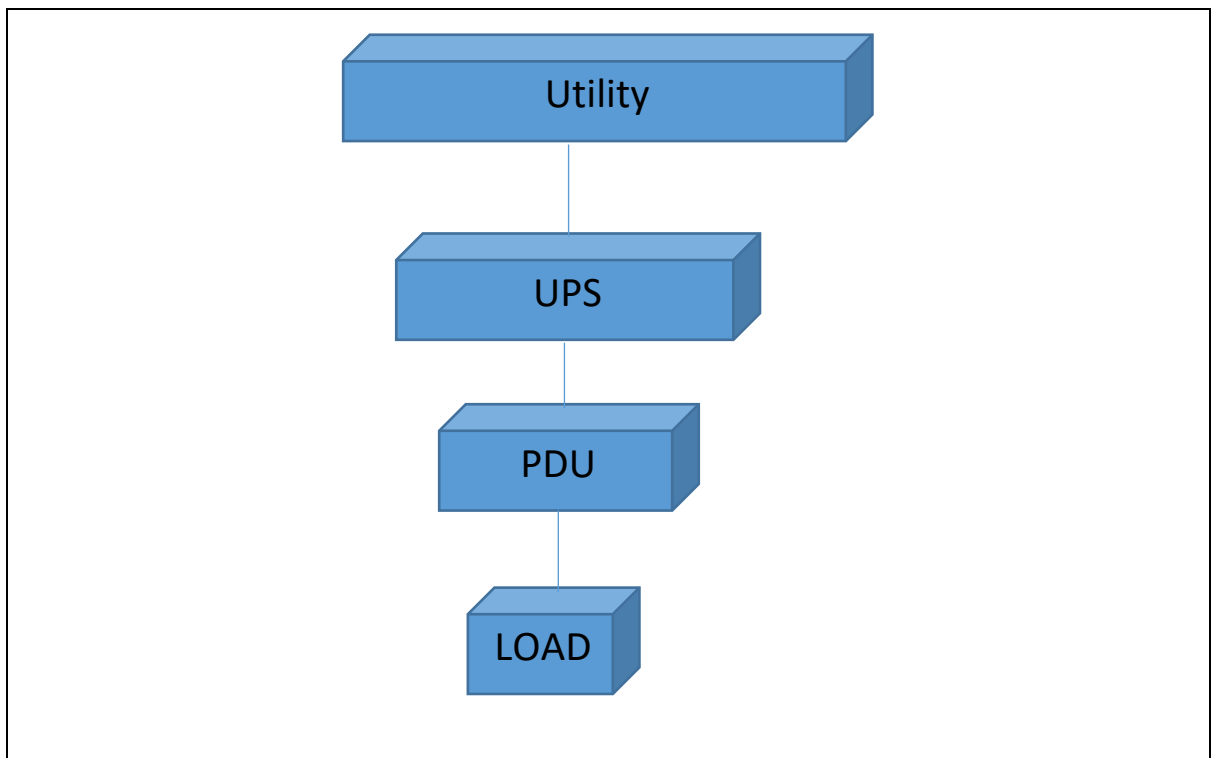

Figure 2.14: Capacity 'N' system configuration

2.9.3 Parallel UPS redundancy configuration 'N+1' and '2N'

The parallel UPS redundancy configuration system allows the UPS modules to operate in parallel as a backup for each other. The UPS supplies the power continuously to the critical loads during commercial electrical power problems. However, if for any reason the UPS is offline or taken out of service for maintenance, then the other UPS can take over the load, without disrupting protected loads [31, 76].

In parallel redundancy configuration, two or more UPS modules are connected in parallel to a common distribution network. This means that the system has enough UPS modules to maintain power to the critical loads during commercial electrical power problems. However,

this redundancy comes in different forms. For instance, a data centre may offer ‘N+1’ and/or ‘2N’ redundancy systems. In this context, data centre managers need a clearer understanding how the redundancy system is configured [32, 76].

2.9.4 ‘N+1’ parallel redundancy configuration

In a N+1 parallel system configuration, there is one or more UPS module than necessary which work together to supply power to the IT load. The UPSs are connected to share the load equally as a conjoined system. Each UPS stands ready to take over the load from another UPS whenever necessary, without disrupting protected loads (see Figure 2.15). For any reason if any modules fail or be taken off-line, each UPS stands ready to take the action over the load from another UPS, in other words, there is sufficient spare capacity to support the load if any one module becomes unavailable [38,76].

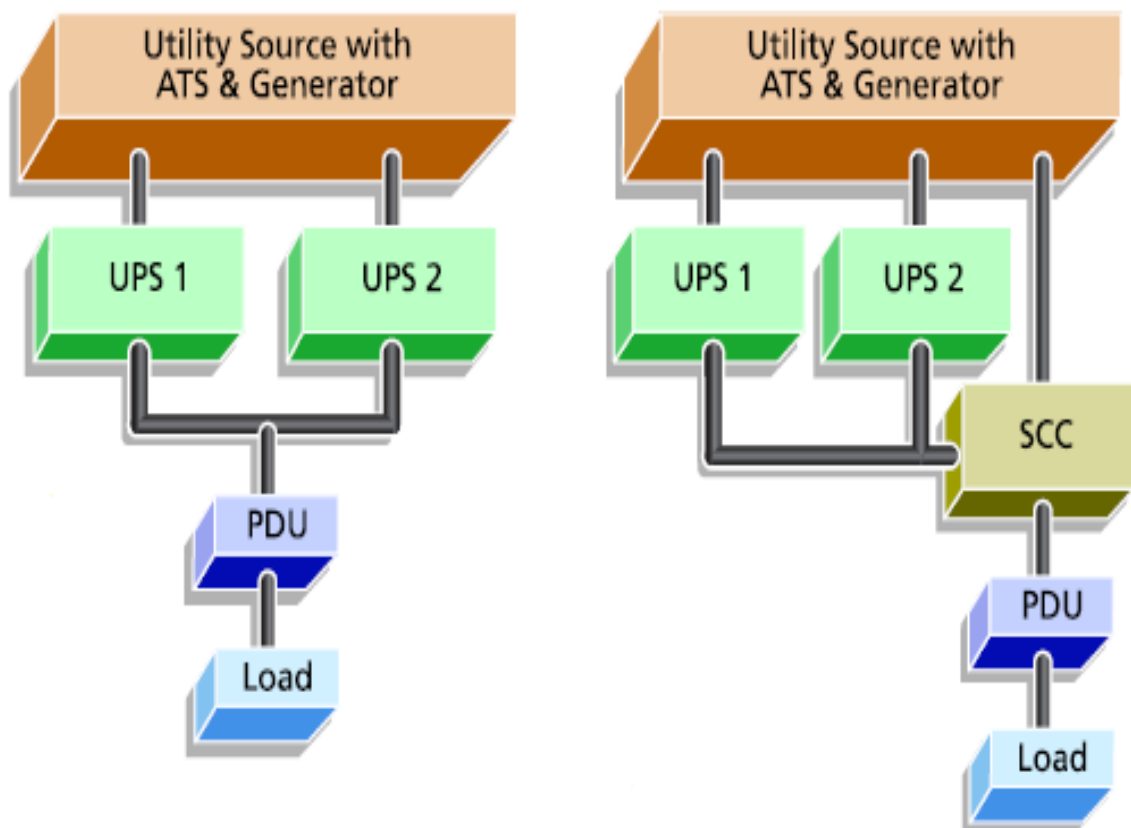

Figure 2.15: ‘N+1’ parallel redundancy configuration

The advantages of using an “N+1” system configuration, are the higher level of availability than capacity configurations because of the extra capacity that can be utilized. The hardware

arrangement is conceptually simple, and cost effective. The disadvantages are both modules must be of the same rating, and the same configuration technology [76].

In this work, for example the parallel redundant (N + 1) system configuration for the static UPS system diagram (see Figure 5.2). Shows the electrical infrastructure topology N+1 redundancy configuration for a medium size data centre. In this case, we need to protect a 1500 kW load by deploying three 1100 kVA UPS modules. During normal operation, the three modules would each carry one-third of the total 1500 kW load. If one module fails, the remaining two UPS modules stand ready to take the action over the load from another UPS and have sufficient capacity to support protected load. Parallel redundant configuration improves availability and allows UPS modules to be serviced without effect the power quality of the connected load.

2.9.5 '2N' parallel redundancy configuration

The 2N system configuration consists of two parallel redundant systems that are connected in parallel to two different power supplies in each IT load. This mean the load of the data centre is shared between two UPS systems or more on independent paths so that if one fails, the other will still supply the data centre critical load (see Figure 2.16). This system's redundant configuration is the most reliable but the most expensive in the UPS industry [38,76].

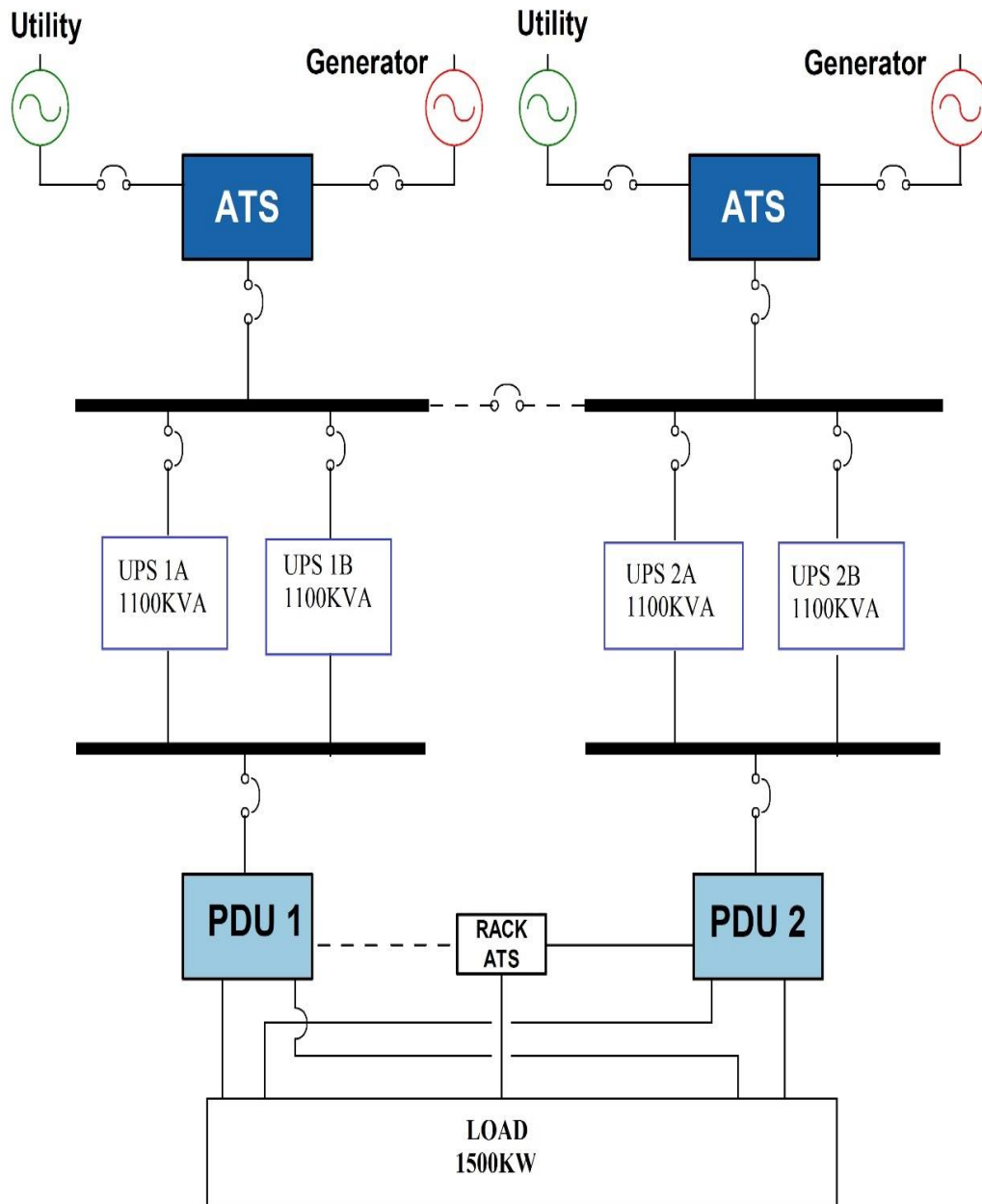

Figure 2.16: '2N' parallel redundancy configuration

In this work, the '2N' parallel redundant system configuration for the static UPS for a medium size data centre designed. In this case, the UPS requirement for the design adopted requires four UPS 1100 kVA modules. Two UPS are paralleled on the 'A' side and the other two UPS are paralleled on side 'B' to give the '2N' redundancy configuration (seen Figure 4.2) [38, 76].

The advantages of using a “2N” system configuration is that the load is shared between two UPS systems or more on independent paths so that if one fails, the other will still supply the data centre critical load for no single points of failure. The disadvantages are Highest cost. This system redundant configuration is the most reliable and most expensive design in the UPS industry [77, 80].

The advantages of using an N+1 configuration system are;

- Expandability to match load requirements
- Simple, low cost economical solution
- Load sharing capability

The disadvantages of using an N+1 configuration system are;

- Exposure to disturbances during maintenance times
- Single UPS output bus

The advantages of using a 2N configuration system are;

- Highly reliable
- required for critical mission situations
- The load of the data centre is shared between two UPS systems or more on independent

The disadvantages of using a 2N configuration system are;

- High Cost
- space requirements

2.10 Data centre energy efficiency

With a growing concern on the considerable energy consumed by data centres. As computing power increases, increasing power density in data centres, energy use, energy costs and carbon emissions are becoming a significant problem to data centre managers and operators [81, 82]. Research looked at the increase in power and energy costs in the data centre industry and the subsequent need for an increase of low carbon data centres. As well they are targeting a green data centres with higher energy efficiency [83, 84].

Therefore, two metrics that have been introduced to describing data centre Power Efficiency, by members of the Green Grid, an industry group focused on data centre energy efficiency [87, 88].

The two metrics are:

- Power usage effectiveness (PUE)
- Data centre infrastructure efficiency (DCIE)

Establishing the two metrics for data centre efficiency by members of the Green Grid, help data centre managers and operators to improve their data centre efficiency performance per watt. Preferably, these metrics will help determine if the existing data centre can be optimized before a new data centre is needed [89, 91].

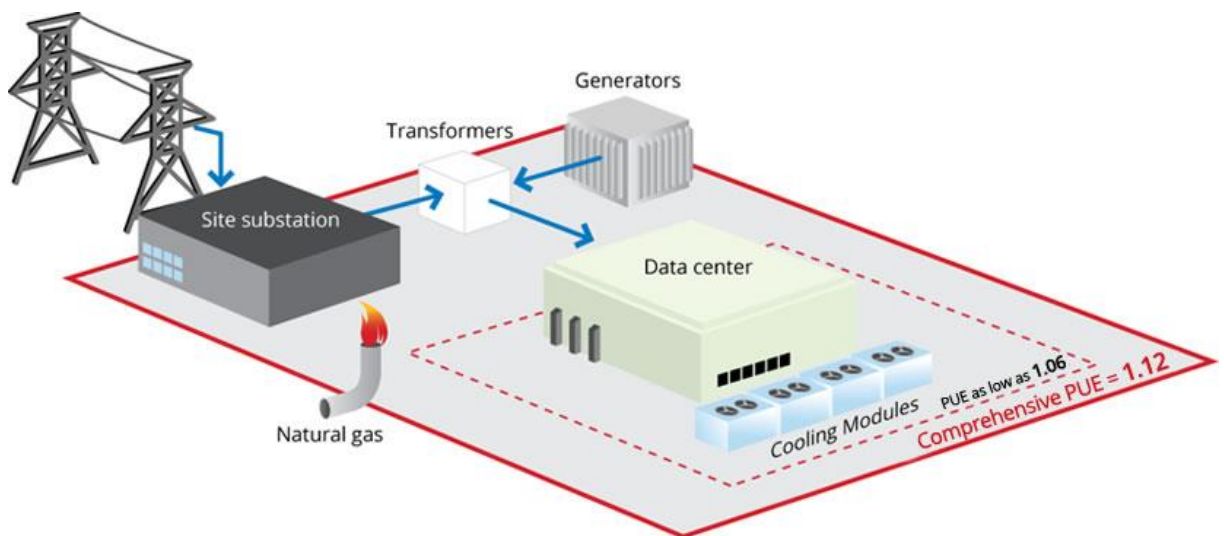

Figure 2.17: Google data centre power usage effectiveness measurement [91].

2.10.1 Power Usage Effectiveness (PUE)

The most common metric used to determine the energy efficiency of a data centre known as the power usage effectiveness (PUE), this metric is defined as the ratio of the total power entering the data centre divided by the power used by the IT equipment [90]. (see Equation 2.2).

$$\text{PUE} = (\text{Total Facility Energy}) / (\text{IT Equipment Energy}) \quad (2.2)$$

Total Facility Power, in this equation, is all the power required to operate the entire data centre, including the servers, storage, network equipment and the support infrastructure items such as fans, UPS, and lighting. IT Equipment Power is the power required to operate the servers and IT equipment alone [92]. Ideal PUE equals 1 and can increase up to infinity.

According to today's standard, PUE at 1.6 or lower is considered to be reasonable, and if the PUE equals 1.4 or lower, then it is considered to be very good, and if the PUE equals 1.2 or lower it is considered excellent [93]. The Uptime Institute indicates that the average PUE rating for a data centre is 1.8, based on a survey of 500 data centres [94, 109].

Several sources result in high PUE values. Typically, 30-50% of IT power is consumed by chillers, then CRAC units consume 10-30% of IT power, followed by UPSs which consume 7-10% of IT power. In which about 7% of energy consumption from the UPS power supply system, and about 3% from UPS input power supply system. Then other facility elements, for instance, PDUs which contain transformers to step the voltage down, and lighting add 2% to PUE levels [95, 102].

2.10.2 Data Centre Infrastructure Efficiency (DCIE)

Data centre infrastructure efficiency (DCIE) is a metric used to define the energy efficiency of a data centre, and calculated by dividing IT equipment power by total facility power. The (DCIE) was developed by Green Grid members, an industry group worked to improve the resource efficiency of information technology and data centre throughout the world [90, 95].

As reported by. "The Green Grid" and "The Uptime Institute standard", if the DCIE about at (0.5) must be considered - quite good, and if the (DCIE) equal (0.7) considered as good, and if the (PUE) equal (0.9) considered almost excellent [96, 101].

$$\text{DCIE} = 1 / \text{PUE} = \text{IT Equipment Power} / \text{Total Facility Power} \times 100\% \quad (2.3)$$

Both, power usage effectiveness (PUE), and data centre infrastructure efficiency (DCIE) are important to take care of greater energy efficiency and there is no doubt at all data centre is a significant cost for any organization, especially when it comes to the energy consumption [97, 98].

The main purpose of both metrics. The PUE and DCIE is to provide easy to be interpreted values which can help to determine [90].

- Opportunities to improve a data centre operational efficiency.
- How a data centre compares with competitive data centres.
- If the data centre operators are improving the designs and processes over time.
- Opportunities to re-purpose energy for additional IT equipment

2.11 Summary

In this chapter, detailed description of data centre back ground, availability classification system and standard, also the UPSs design and topology, operation, and applications has been presented with emphasis on double-conversion static UPS systems and flywheel UPS technology systems. Basic principles of parallel operation have also been explained. A general classification of UPS systems has been explained. In addition, different configurations as well as basic control strategies for UPS systems operated in parallel have been described.

This research finds critical areas which require a focus on. For data centre owners and managers, to help in selecting the right UPS system for the right site. The critical areas of research are shown below.

- some of the previous studies concentrated on the static UPS technology, double conversion UPS deploy in data centre, in terms of efficiency only, based on just one configuration. Without considering the other types.
- There is a need to understand the difference between the most two common types of UPS units that are seen in the market today, in a different electrical infrastructure 2N and N+1 topologies.
- Another important aspect in the choice of an energy storage device is its costs. A few studies have concentrated on analysis of the cost comparisons between the two UPS systems.

This research seeks to conduct a more empirical investigation. By a series studies, simulations and calculations in an electrical model for a medium size data centre is designed to provide 1500 kW to IT load based on 2N and N+1 configuration. The study will be undertaken to determine which UPS technology and topology can improve data centre energy efficiency and reduce the cost.

Finally, data centre energy efficiency measurement metrics. These metrics are briefly described in this chapter and have been used in this work, to compare the both technologies, and determine if the existing data centre can be optimized before a new data centre is needed. And identify possible points of improvement and then assess results of these improvements.

Chapter 3: METHODOLOGY AND BACKGROUND

3.1 Introduction

This dissertation is designed to provide data centre managers and operators, with a clearer understanding of key factors and considerations involved in selecting the right UPS system, and how can future UPS system topology and technology improve the data centre in terms of efficiency and cost. An electrical model for a medium size data centre is designed to provide 1500 kW to support the IT load to the data halls. The data centre selected is assumed to be of the modular type operating on free air cooling which has been calculated to be available for 99% of the year in London based on ASHRAE, (American Society of Heating, Refrigerating and Air-conditioning Engineers). The designed IT load is 1500 kW, which is the maximum cooling available from the mechanical systems. This in turn, is the maximum power density of the facility. Computer based software programs such as the ‘ROMONET’ are used to offer a predictive modelling tool for the data centre in order to evaluate how it would operate under different conditions. For the purpose of this research project, devoted Excel Calculation spread sheets have been created to allow the user to translate and include the manufacturer data properly so that a reasonable investigation of the distinctive frameworks can be attempted. The system is designed in accordance with the Uptime Institute Tier III requirements, the Uptime Institute specify that all the IT equipment is dual chorded or powered in that it can accept both an A and B supply from alternate sources [31,32]. The electrical infrastructure topology to be adopted is configured to ‘2N’ and ‘N+1’ redundancy configuration [76,77], for each of the two UPS systems technologies double conversion Static UPS system and flywheel, where ‘N’ stands for the number of UPS modules that are required to supply power to data centre. This chapter will introduce the methodology how we analyse the impact of which different UPS technologies and their operating efficiencies of the Data Centre by clarifying the points below:

- **‘ROMONET’ Computer based software programs**
- **What is N Capacity system configuration**
- **Tier III Facility**
- **Two UPS technology comparison in 2N Configuration system**
- **Two UPS technology comparison in N+1 Configuration system**
- **Power usage effectiveness (PUE)**
- **Data centre Infrastructure Efficiency (DCIE)**

- **Data centre energy and UPS Cost**
- **Excel calculation spread sheets have been created**

3.2 ‘ROMONET’ Computer based software programs

Romonet, is a powerful predictive modelling software program, for data centre. Provides a predictive, detailed breakdown of a data centres operation, energy consumption and running costs. This can be done for any point in the facilities life time and at any part load condition. Once a Romonet model is created a dynamic simulation can be run using actual weather data for the site and a complete hour-by-hour energy profile for the facility can be generated. From this, full life-cycle performance metrics for varying environmental conditions and IT equipment loads can be generated These metrics include: PUE, DCIE, Energy and Cost. The Romonet software suite enables both a data centre designer and data centre owners to reduce operational and financial risk [44].

3.2.1 Romonet software functional description

Romonet, software provides you with the tools to design, build and manage a more efficient data centre. Whatever the stage of a data centre lifecycle, the suite allows you to discover the true cost of your IT services and accurately predict, account and optimise cost, energy and capacity – holistically or at a component level [44].

Also, Romonet software can manage data centre risk, suite takes the risk out of change because you’re able to model all kinds of ‘what if’ scenarios and make informed decisions about the future based on facts, not assumptions. It dramatically reduces the time taken to evaluate new technology and equipment and enables new capabilities and capacity to be rapidly developed and deployed without unnecessary cost and risk [45].

3.2.2 Key features and benefits

Romonet, software provides powerful financial and energy analysis within a simulated data centre environment. It gives you the information you need to plan with confidence.

- Cost to serve.

Calculate the full and real cost of delivering energy to IT equipment.

- Cost forecast and analysis

Analyse capital, operational and other costs per device per hour, per month, per annum.

Forecast your energy costs based on future demand and understand sensitivities to changing power costs and seasons.

- Efficiency modelling

Analyse the cost of inefficient components hour-by-hour, month-by-month, and understand how to optimise efficiency - reliably and without risk.

- Energy performance

Test new designs and technology under different operating conditions before you commit to change.

In this work, Romonet is used to calculate the parameters which shall be analysed in the following chapters.

3.3 What is 'N' capacity system configuration

The using of the Letter "N" when designing UPS configurations can simply be defined as the number of UPS modules that are required to supply power to IT load. In other words, the minimum backup protection required to feed the critical load [76]. It is a common configuration system in the UPS industry. In normal operation mode, The critical load is supplied by the inverter. But in the event of the UPS is offline or taken out of service for maintenance, then the UPS change to bypass mode and served the load through the bypass line (see figure 3.1). This means the critical load is directly supported by utility power. This configuration offers less redundancy; therefore, limit the load protection [31, 76].

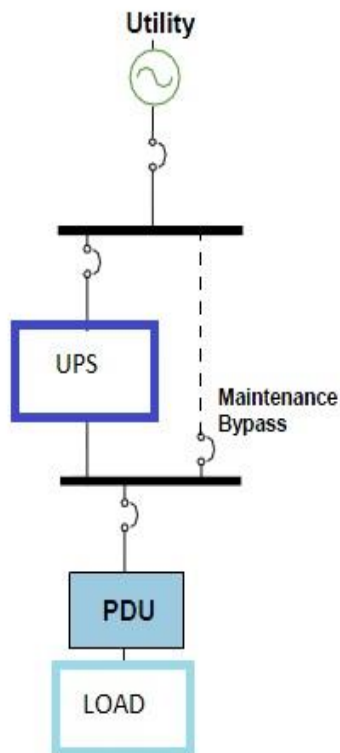

Figure 3.1: Capacity 'N' system configuration

The parallel UPS redundancy configuration system allows the UPS modules to operate in parallel as a backup for each other. The uninterruptible power supply (UPS) continuously supply the power to the critical loads during commercial electrical power problems. But in the case for any reason that the UPS is offline or taken out of service for maintenance, so the other UPS stands ready to take over the load from another UPS whenever necessary, without disrupting protected loads [76,77].

A different data centre enterprise provides sufficient redundancy to deal with any unexpected power outages. But redundancy comes in different forms. For instance, data centre may offer 'N+1' and '2N' redundancy systems. However, data centre managers need clearer understanding how the redundancy system is configured. In parallel redundancy configuration, two or more UPS modules are connected in parallel to a common distribution network. That mean the system has enough UPS modules continues to maintain power to the critical loads during commercial electrical power problems [78].

3.3.1 'N+1' Parallel redundancy configuration

N+1 redundancy is a formula meant to express a form of resilience used to ensure system availability in the event of a component failure. The formula suggests that components (N) have at least one independent backup component (+1). The "N+1" is an additional component or system to ensure that the UPS system is always available. N+1 stands for the number of UPS modules that are required to handle an adequate supply of power for essential connected systems, plus one more. On other words, there would be sufficient spare capacity to support the load if any one module became unavailable [31,76].

In this work, for example the Parallel Redundant (N + 1) System Configuration for the Static UPS system Diagram, (see Figure 5.2). The electrical infrastructure topology N+1 redundancy configuration for a medium size data centre designed to provide 1500 kW to support the IT load. In this case, we need to protect a 1500 KW load by deploying three 1100 kVA UPS modules. During normal operation, the three modules would each carry one-third of the total 1500 kW load. If one module fails, the remaining two UPS modules stand ready to take the action over the load from another UPS and have sufficient capacity to support protected load. Parallel redundant configuration improves availability and allows UPS modules to be serviced without effect the power quality of the connected load.

3.3.2 '2N' Parallel redundancy configuration

The 2N System Configuration consists of two parallel redundant systems that are connected in parallel to two different power supplies in each IT load, that's mean the load of the data centre is shared between two UPS systems or more on independent paths so that if one fails, the other will still supply the data centre critical load. This system redundant configuration is the most reliable and most expensive design in the UPS industry [77, 80].

In this work, for example, the Parallel Redundant (2N) System Configuration for the Static UPS system Diagram, for a medium size data centre designed to provide 1500 kW of cooling capacity and IT load. (see Figure 4.2). In this case, the UPS requirement for the design adopted requires four UPS 1100 kVA modules. Two UPS are paralleled on "A" side and the other two UPS are paralleled on side "B" for the '2N' redundancy configuration.

3.4 Tier III facility

In this type the data centre has redundant capacity components and multiple paths, simultaneously serving the site's computer equipment. All IT equipment is dual powered and fault-tolerant site infrastructure is also required for electrical power storage and distribution facilities [31]. The distribution path and complementary system must be separated and isolated, to prevent any single event from affecting both systems [32]. Figure 3.2 shows Infrastructure Tier III classification [38, 39].

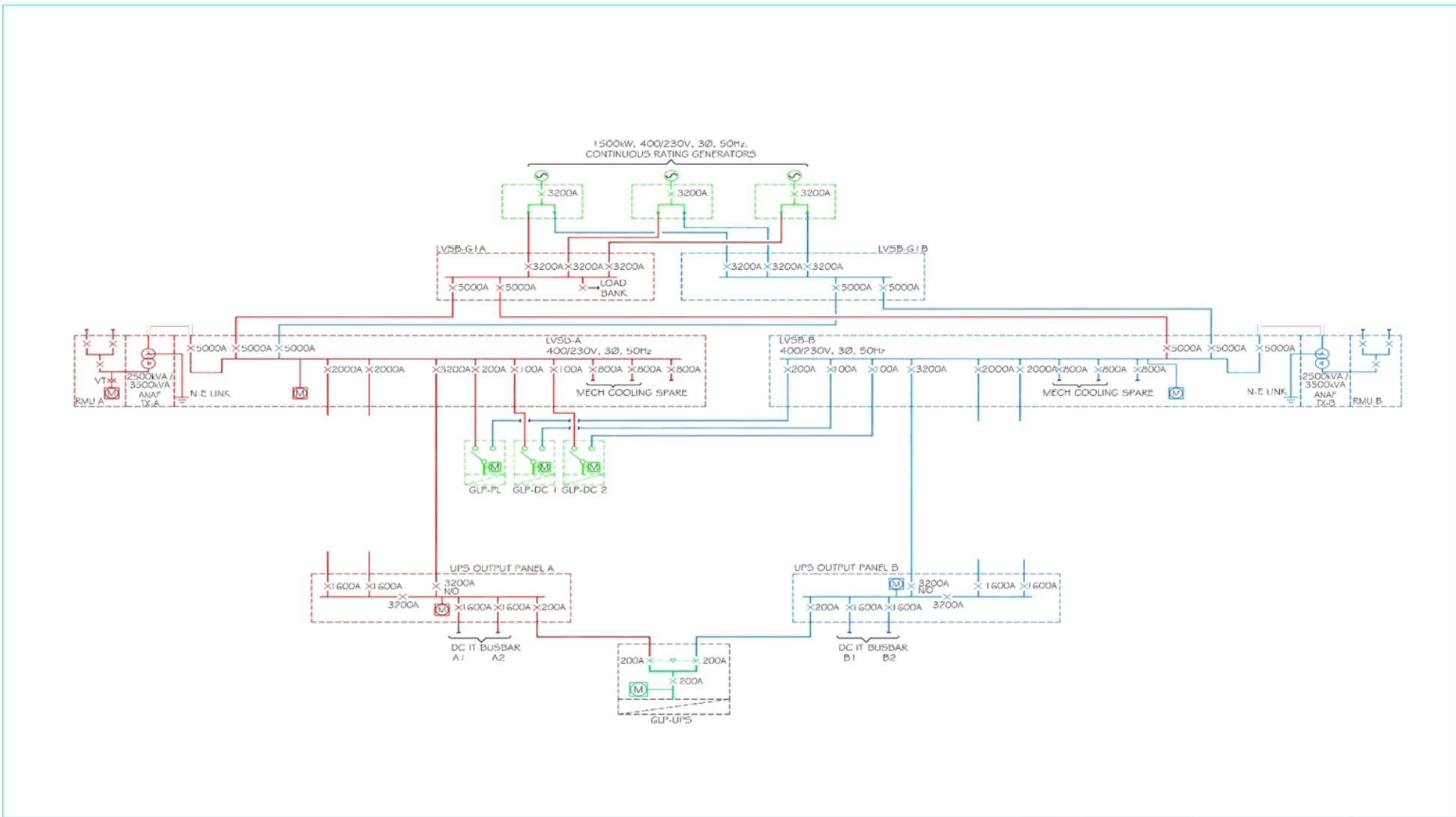

Figure 3.2: Infrastructure Tier III classifications

3.5 Power Usage Effectiveness

The most common metric used to determine the energy efficiency of a data centre known as the power usage effectiveness (PUE), this metric is defined as the ratio of the total power entering the data centre divided by the power used by the IT equipment [88]. The total facility power, is all the power required to operate the entire data centre, including the IT equipment items servers, storage, network equipment and the infrastructure support items: fans, UPS, and lighting [89]. IT Equipment Power is the power required to operate the servers and IT equipment alone. Ideal PUE equals 1 and can increase up to infinity [90, 130].

Another study by (The Uptime Institute) indicates that the average Power Usage Effectiveness (PUE) rating for data centre is 1.8, set of 500 data centre surveyed [31,32].

Several sources are lead to high PUE values, typically 30-50% of IT power consumed by chillers, then the computer room air conditioning (CRAC) units, consuming 10-30% of IT power, followed by uninterruptible power supply system (UPSs), through several power conversion stages and that consume 7-10% of IT power. Other facility elements, for instance, power distribution units (PDU) which contain transformer to step the voltage down, and lighting consuming 2% add to higher PUE levels [92,94].

The PUE is presented as a fraction above to help Data Centre Operator to improve the efficiency of their facilities, if the given value is above 1, this means lower facility efficiency [93]. However, the value will always be greater than one but the closer it is to 1 the better the Data Centre is perceived in terms of energy efficiency. Also, the PUE enables comparison to be made with other similar facilities that are perhaps operating different mechanical and UPS systems [102].

3.6 Data centre infrastructure efficiency

Data centre infrastructure efficiency is a metric used to define the energy efficiency of a data centre, and calculated by dividing IT equipment power by total facility power. The DCIE was developed by Green Grid members, an industry group worked to improve the resource efficiency of information technology and data centre throughout the world [95, 96].

Both, power usage effectiveness (PUE), and data centre infrastructure efficiency (DCIE) are important to take care of greater energy efficiency and there is no doubt at all data centre is a significant cost for any organization, especially when it comes to the energy consumption [90, 100].

3.7 Data centre energy and uninterruptible power supply (UPS) cost.

In this study where the data centre has been designed will not operate at 100% load from day one. The data centre cost comparison is directly related to the power absorbed. At £0.10 per kwh the electricity cost for 12 months of operation at 50% loading. Therefore, the maximum design load on each UPS in normal operation cannot exceed 50%. 2N systems rarely achieve even 50% load on each system. Some field surveys indicate that 2N data centres operate at 20-40% of their 2N capacity [80].

A lifecycle period of five years has been captured based on the initial capital investment [105, 106], along with all the maintenance and operational costs which have been detailed in next chapter. Also, the cost calculation for the uninterruptible power supply (UPS) and data centre energy are straight related to the consumed power. At £0.10 per kWh. And the cost of the electricity calculated for one year of operation at 50% loading and recorded against site load ranging from 25% right up to 100% [80].

3.8 Summary

Chapter three, introduced the methodology how we analyse the impact of which different UPS technologies and their operating efficiencies of the data centre, by using ROMONET software to calculate the parameters under different conditions. All using a N+1 parallel system configuration and 2N System Configuration for each of the two UPS systems technologies. To help data centre owners and managers selecting the right UPS system for the right site.

Also, in this chapter a tier III data centre is introduced which is used in this study. As it is concurrently maintainable, allowing for any planned maintenance activity of power and cooling systems to take place without disrupting the operation of computer hardware located in the data centre. In terms of redundancy, tier III offers N+1 and 2N availability.

Finally, data centre energy efficiency measurement metrics. These metrics are briefly described in this chapter and have been used in this work, to compare the both technologies, and determine if the existing data centre can be optimized before a new data centre is needed. And identify possible points of improvement and then assess results of these improvements.

Chapter 4: DESIGN DESCRIPTION FOR 2N REDUNDANCY CONFIGURATION

4.1 Introduction

A data centre can consist of a large group of networked servers and associated power distribution, networking and cooling equipment. All these applications consume enormous volumes of energy which can result in a significant increase in energy inefficiency problems [1, 3]. One of the causes of data centre energy inefficiency power distribution is the UPS [47]. This study attempts to answer the question of how can future UPS topology and technology improve the efficiency of data centres. In order to analyse the impact of different UPS technologies and their operating efficiencies, a model for a medium size data centre is developed, and load schedules and worked diagrams are created to analyse and test the components of each of the UPS system topologies.

The UPS system is an alternate or backup source of power, linking between mains power supply and end critical loads, to provide back-up power and to protect the sensitive load against line frequency variations [50]. The main UPS systems deployed in data centre applications are Static, flywheel, and Diesel Rotary UPS [49]. However, the focus of this work is on the Static and flywheel UPS systems. It analyses the operating efficiencies of the different UPS technologies on the overall PUE of the data centre. The PUE is presented as a fraction whereby the total facility power inclusive of all losses is divided by the power consumed by the data centre's IT equipment. If the PUE is equal to 1 this means it is a perfect efficient facility, if the given value is above 1, which is always the case, this means a lower facility efficiency [88]. Overall, the closer the PUE is to 1 the better in terms of energy efficiency. In order to analyse the different UPS technologies and their operating efficiencies a model for a medium size data centre is developed based on a data centre designed to provide 1500 kW to support IT load. The electrical infrastructure topology adopted is configured to '2N' redundancy configuration for each of the two UPS systems technologies, double conversion online ups and flywheel ups. Where 'N' stands for the number of UPS modules that are required to supply power to data centre [31, 76]. The '2N' redundancy means the load of the data centre is shared between two UPS systems on independent paths so that if one fails, the other will still supply the data centre's critical load [80]. In addition, the entire critical load will be less than one half of the total UPS capacity installed. Computer based software programs, such as the [Romonet], are used to offer a predictive modelling tool for the data centre in order to evaluate how it would operate under different conditions. The

system is designed in accordance with the Uptime Institute Tier III requirements, which specify that all IT equipment is dual chorded or powered in order that it can accept both an A and B supply from alternate sources [31,107].

4.2 Design description

An electrical model for a medium size data centre is designed to provide 1500 kW to support IT load. The data centre selected is assumed to be of the modular type operating on free air cooling which has been calculated to be available for 99% of the year in London based on ASHRAE weather data. The designed IT load is 1500 kW, which is the maximum cooling available from the mechanical systems. This, in turn, is the maximum power density of the facility. The electrical infrastructure topology adopted is configured to ‘2N’ redundancy configuration for each of the two UPS systems technologies, Static and flywheel. The system is designed in accordance with the Uptime Institute Tier III requirements [31, 32]. Table 4.1 outlines the loading accounted for when sizing the UPS.

Table 4.1: Electrical Loading Summary for Data Centre

Units	kW	kW	kVA	A	Remarks
Total IT Load	1500				
Data Centre Ventilation (Fan Load)	150				
Total UPS Load		1,654	1,838	2,653	Assume P. F=0.9
Total UPS Input Load (incl. charging current & losses)		1,997	2,264	3,268	UPS charging current = 15% UPS Losses = 5%
Total Non-UPS Mechanical Cooling Load		0	1	1	Assume P. F=0.9
Total non –UPS Mechanical Cooling Load		0	1	1	P. F=0.76
Total non – UPS[excl- Mechanical Cooling Load		0	0	0	P. F=0.9
Total non – UPS[incl- Mechanical		0	1	1	P. F=0.76 Mechanical

Mechanical Cooling Load					Load= 0.9 GLB
Total Load		1,997	2,264	3,268	

4.3 2N Redundancy configuration diagram for a medium data centre

The ‘2N’ system configuration as seen in Figure 4.2, consists of two parallel redundant systems that are connected in parallel to two different power supplies in each IT load, which means that the load of the data centre is shared between two UPS systems or more on independent paths so that if one fails, the other will still supply the data centre critical load. This system’s redundant configuration is the most reliable and most expensive design in the UPS industry [77].

From an electrical design standpoint, a data centre is a hierarchy of electrical devices that transmit power from a utility feed to server racks as seen in Figure 4.2. One or more feeds arrive from the electrical utility after their voltages are transformed to usable levels. Switchgear provides, among other things, a disconnect point for the utility feed. Where needed, UPS and generators provide transient and longer-term backup power. Conduit and wire ways feed distribution systems in the data centres themselves. Power distribution mechanisms deliver electricity to racks and standalone systems. Within racks, smaller distribution systems provide power to individual servers [80]. The diagram for a medium data centre consist of.

- Switchgear

Data centres use switchgear and distribution boards to safely distribute power from the utility to the data centre floor. The switchgear includes circuit breakers and switches for managing medium and low voltages and they are typically used to distribute large amounts of power to various locations within data centres and buildings.

- Medium-voltage / Low voltage Transformer

Typically, the utility supplies a medium voltage (MV) service to a dedicated data centre. Then the MV is stepped down to low voltage (LV) by a MV/LV transformer located in the data centre. LV power is distributed to the different electrical loads such as IT devices inside the racks, cooling system, lighting [79].

- Backup generators

Backup generators are used to power critical equipment in the event of a utility power failure. Backup power is sometimes supplied to the main switchgear, sometimes it is provided further down in the distribution system. Backup power generators cannot

start instantly, so another form of backup power needs to continue to power data centre equipment during the interval of eight seconds or less that is needed to start the generators and ready them to carry the data centre and support loads. The traditional approach is to use UPS system [79].

- Power Distribution

Conduit and wire way distribute the conductors that run from the switchgear to the data centre itself, where typically one of three techniques are used to distribute power to racks.

- uninterruptible power supply UPS

UPS systems are typically installed in the electrical space or IT space of the data centre to provide uninterrupted power to the critical equipment it supports. with input/output switchboard and UPS distribution switchboard. In this case, as Figure 4.2 shows, the UPS requirement for the design adopted requires four UPS 1100kVA modules. Two UPS are paralleled on “A” side and the other two UPS are paralleled on side “B” for the ‘2N’ redundancy configuration.

- Power distribution units (PDUs)

Typically consist of multiple distribution panel boards and can also include internal transformers. (PDUs) without transformers are typically called remote power panels (RPPs). PDUs tend to have a significant amount of built-in intelligence and monitoring capabilities. PDUs are typically installed on the data centre floor throughout the space. PDUs can be used in both slab and raised-floor data centres.

- Bus way

- Panel board

- Rack Power Distribution

Inside each rack is a power strip or rack-mounted power distribution unit (rPDU) that distributes power to the IT equipment installed in the rack.

4.4 Double conversion UPS system based on 2N redundancy configuration

The preferred static UPS technology used in this work is the double conversion static UPS technology, which is the predominant one used in the data centre industry. It uses an insulated-gate bipolar transistor (IGBT) for power conversion [89]. The UPS selected for this design is a transformer less system and has the capability to operate in the Eco mode which is one of the several UPS modes of operation that can improve data centre efficiency. In this UPS mode, there are two main paths that can supply the load, the online double conversion path and the bypass path [63]. Hence, the efficiency of the static UPS is derived measuring the UPS losses in double conversion mode. Table 4.2 and Figure 4.1 shows the results, based on a 1100 kVA system around the data centre model. A higher efficiency of 6-10% can be achieved with the Static UPS by operating it in the Eco mode.

Table 4.2: 1100 kVA Static UPS efficiency from 5% up to maximum capacity

UPS Load	5%	10%	20%	30%	40%	50%	60%	70%	80%	90%	100%
Efficiency	55.6%	72.8%	84.0%	88.5%	90.3%	92.1%	92.9%	93.3%	93.9%	94.1%	94.3%

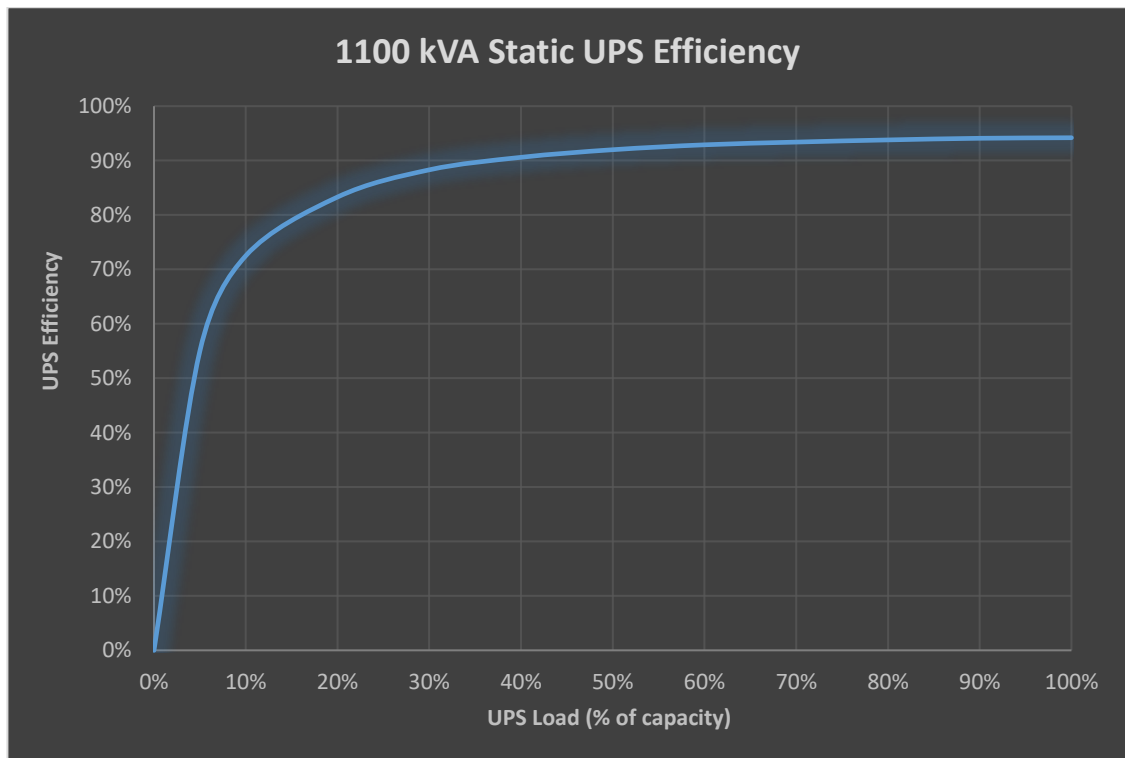

Figure 4.1: Static UPS efficiency curve

Table 4.2 and Figure 4.1 clearly highlight the efficiency of this system along the complete spectrum of loads from 5% up to maximum capacity. Considering a '2N' redundancy configuration at maximum capacity, this is reflected as a 50% loading on the UPS at maximum capacity which would result in losses of 8% on this Static UPS. However, large heat losses are experienced at low loading. To overcome this event, modular UPS systems such as the 1100 kVA system studied, can operate a UPS module management programme if the load is only 100 kVA. Only three of the four 225 kVA UPS modules will run in double conversion, with the other module switching to double conversion immediately, if there is a load increase or power disturbance is experienced.

4.4.1 '2N' Redundancy configuration for static UPS system diagram

In this study, the Parallel Redundant (2N) System Configuration for the static UPS system diagram, for a medium size data centre designed to provide 1500 kW to support the IT load is shown in Figure 4.2. In this case, the UPS requirement for the design adopted requires four UPS 1100 kVA modules. Two UPS are paralleled on "A" side and the other two UPS are paralleled on side "B" for the '2N' redundancy configuration.

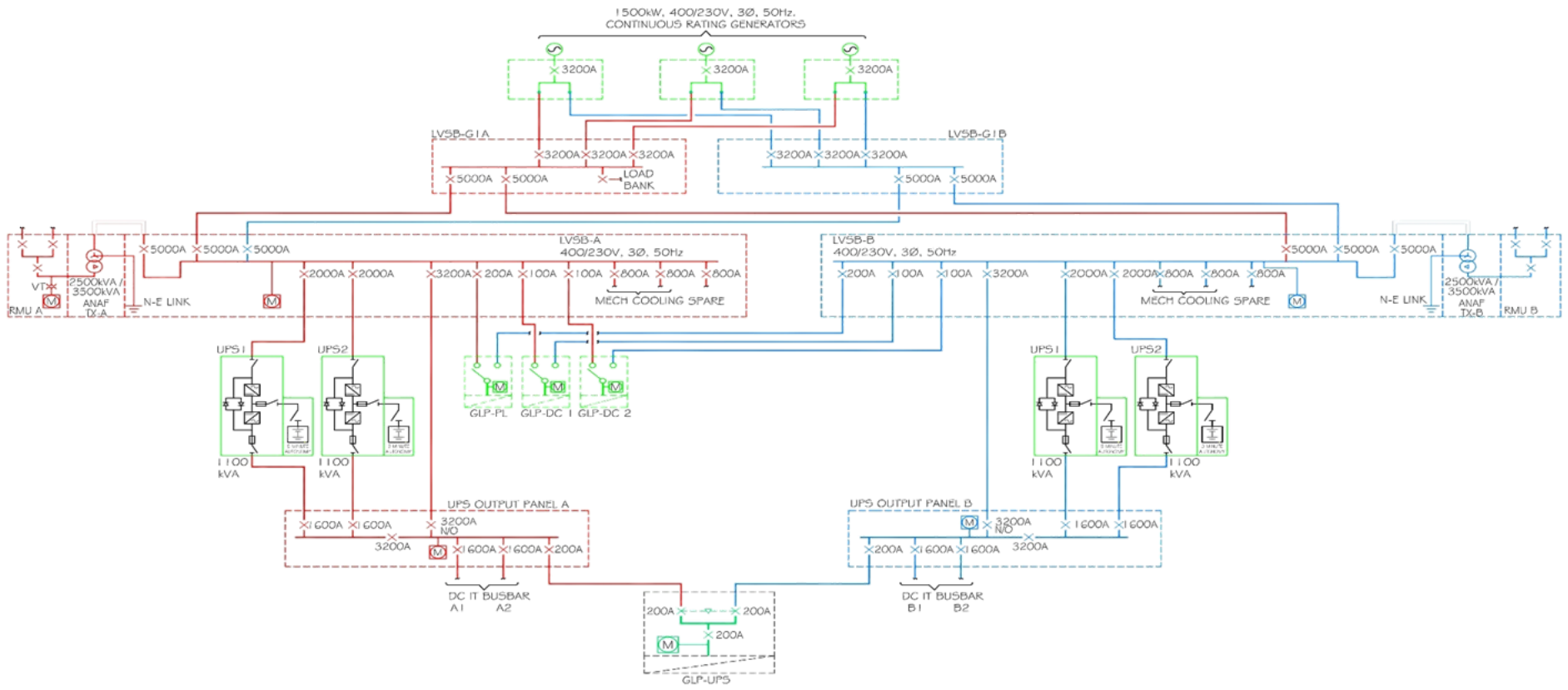

Figure 4.2: '2N' Redundancy configuration static UPS diagram in a medium data centre

The system selected is scalable in blocks of 275 kVA up to a maximum of 1100 kVA; the UPS requirement for the design adopted requires four UPS 1100 kVA modules. Two UPS are paralleled on “A” side and the other two UPS are paralleled on side “B” for the ‘2N’ redundancy configuration. Table 4.3 details the output findings from the static UPS system (Double Conversion Type) in the ‘2N’ redundancy configuration system. The calculations were undertaken for the data centre designed to provide 1500 kW of IT load.

Table 4.3: Static UPS findings in 2N redundancy configuration

IT Load %	100%	75%	50%	25%
Load kW	1500	1125	750	375
PUE	1.27	1.34	1.48	1.91
UPS Load	41.8%	32.1%	22.4%	12.6%
UPS Efficiency	90.88%	88.83%	85.06%	76.21%
Impact on PUE	0.11	0.14	0.21	0.41
kWh	16,708,102	13,197,684	9,739,031	6,264,588
Cost [0.1 £/kWh]	£1,670,710	£1,319,668	£973,903	£626,359
UPS kWh	1,456,765	1,399,188	1,366,514	1,363,322
UPS Cost [0.1 £/kWh]	£145,676	£139,919	£136,651	£136,322

The ‘2N’ redundancy configuration 100% loading will only ever represent a 50% loading on the site UPS as there will always be a minimum of 50% redundancy [76]. The impact this redundancy has on efficiency is shown in Table 4.3 with the UPS efficiency at 25% site load running at approximately 76.2%, i.e. 23.8% losses, and a maximum UPS double conversion type efficiency peaking at 90.88%. Figure 4.3 shows the static UPS efficiencies in ‘2N’ redundancy configuration at part load.

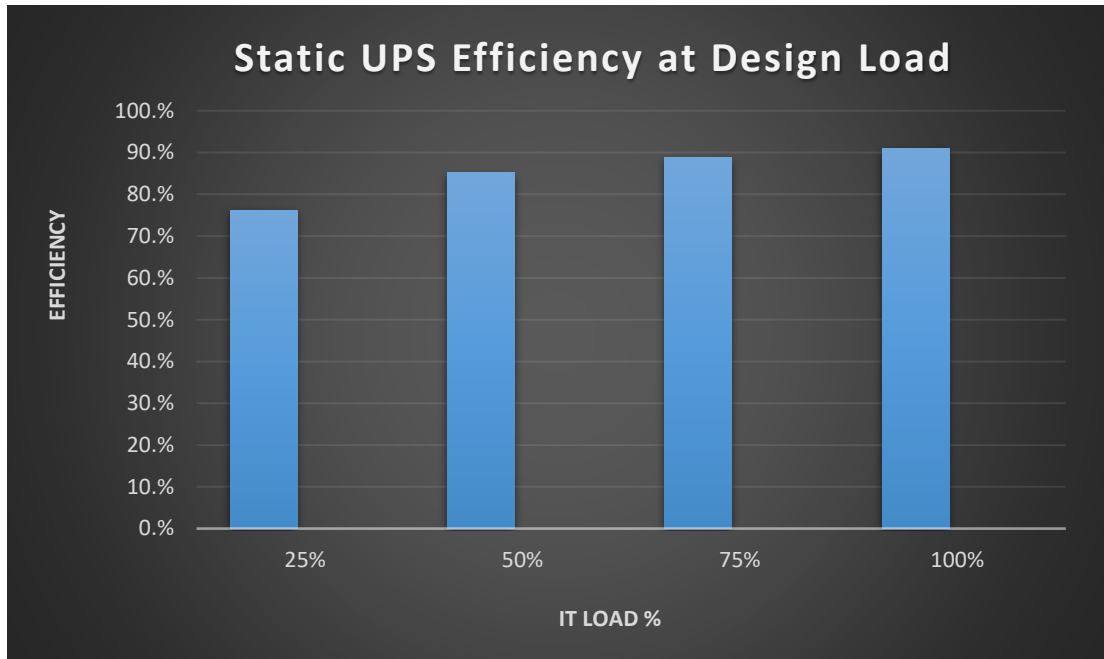

Figure 4.3: Static UPS efficiency at design load

4.4.2 The power usage effectiveness (PUE) of the 2N redundancy configuration static UPS

PUE was developed by the Green Grid industry consortium in 2007. An ideal PUE of 1.0 indicates that all the energy going into the data centre is being put to productive use in data processing, as opposed to being sucked up for jobs such as cooling, power distribution, and lighting. The Green Grid defines the PUE, as measures the relationship between the total facility energy consumed and the IT equipment energy consumed. The higher the PUE, the more energy is being wasted [31, 88]. Data centre power and cooling are two of the biggest issues that organizations face in controlling costs. Determining your data centres PUE can help improve operational efficiency and allows you to see where you can improve on the design and processes [89]. Table 4.4 shows the PUE, of the ‘2N’ redundancy configuration Static UPS based on calculations undertaken for a data centre designed to provide 1500 kW of IT load.

Table 4.4: the PUE findings for the static UPS in 2N redundancy configuration

IT Load %	100%	75%	50%	25%
PUE	1.27	1.3	1.5	1.9

Figure 4.4 represents the PUE for the data centre at various levels of IT load as the total facility power inclusive of all losses is divided by the power consumed by the data centre’s IT equipment. Clearly that this metric moves closer to 1 at the maximum load 100%. At 25% load, the UPS inefficiencies contribute to 21.4% of this value.

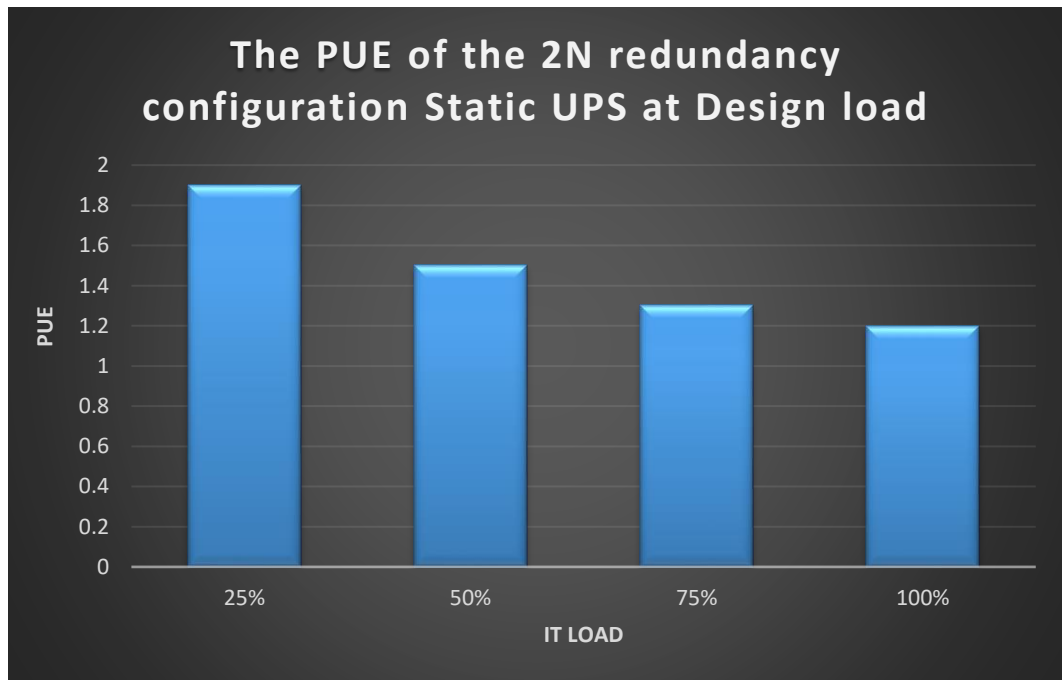

Figure 4.4: the PUE of the 2N configuration static UPS at design load

4.4.3 The effect on the system cost

For the data centre managers and operators selecting the correct UPS for deployment in terms of cost can be a difficult proposition. Therefore, clarifying the data centre's energy costs and the impact of the UPS on overall energy costs is important. In this work, the cost calculation for the data centre energy is straight related to the absorbed power. At £0.10 per kWh. And the cost of the electricity calculated for one year of operation at 50% loading and recorded against site load ranging from 25% right up to 100%. The cost calculation for the data centre energy and the static UPS at various loads is shown in Table 4.5.

Table 4.5: Date centre energy and the static UPS cost findings

IT Load %	100%	75%	50%	25%
kWh	16,708,102	13,197,684	9,739,031	6,264,588
Cost [0.1 £/kWh]	£1,670,710	£1,319,668	£973,803	£626,359
UPS kWh	1,456,765	1,399,188	1,366,514	1,363,322
Static UPS Cost [0.1 £/kWh]	£145,676	£139,919	£136,651	£136,322

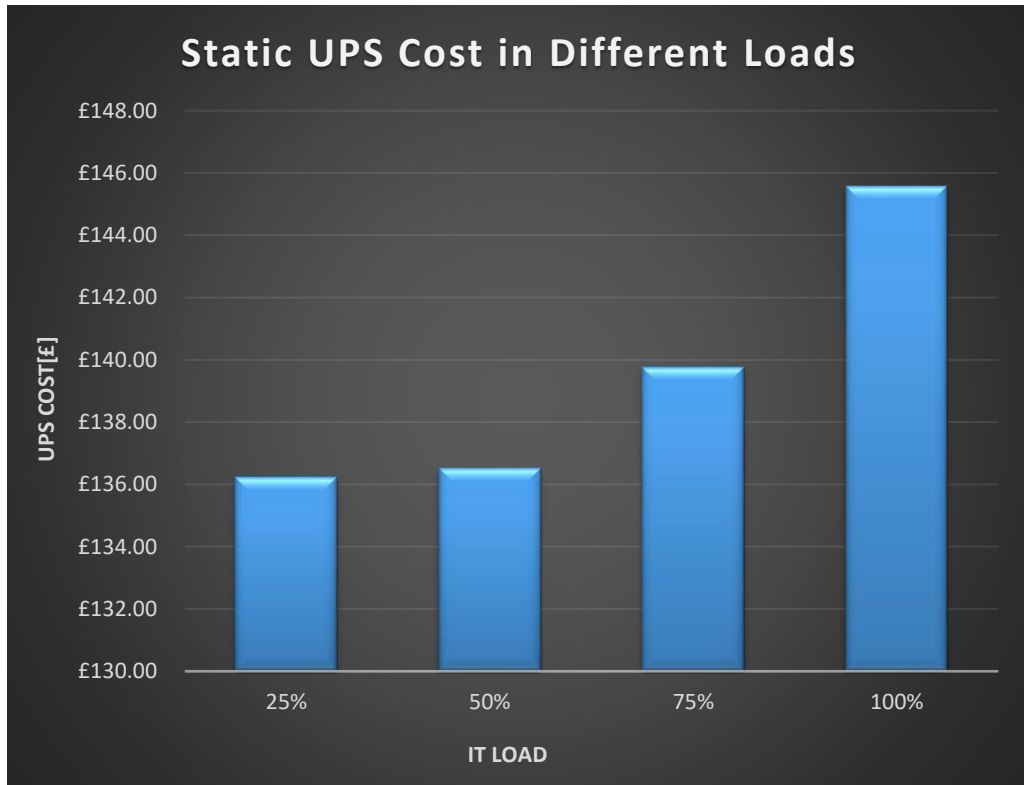

Figure 4.5: Static UPS cost in different loads

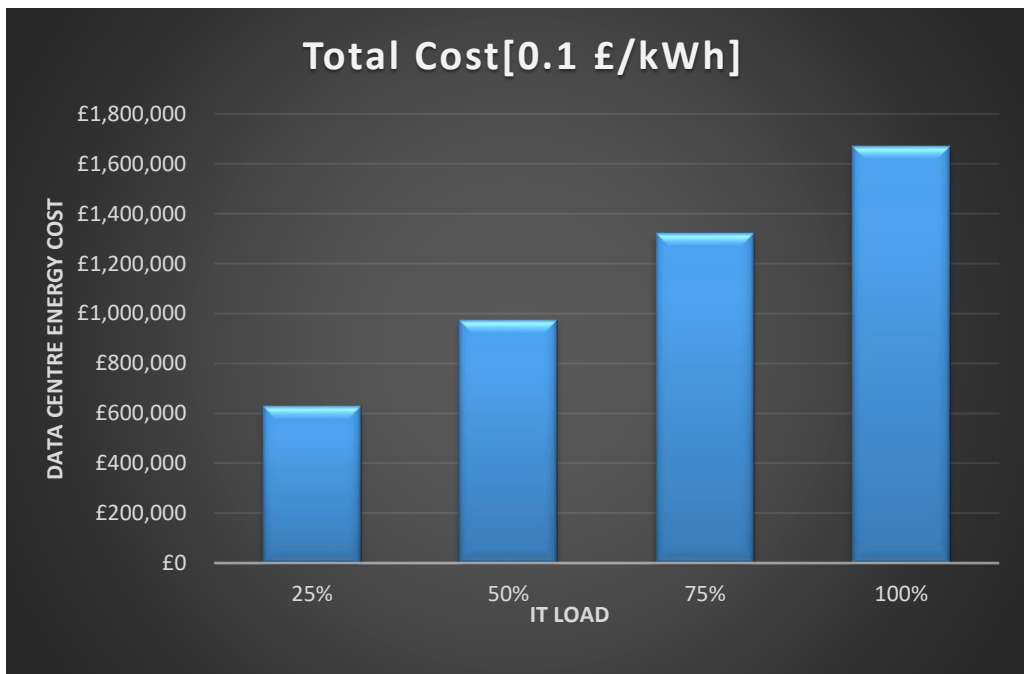

Figure 4.6: Total energy cost in different loads static technology

The effect of the '2N' configuration static UPS at the design loads has on the overall cost is delineated in Table 4.5 and Figures 4.5 and 4.6, based various loads 25% (375 kW connected

IT load) to 100%, at which the facility is operating at design maximum capacity. The annualized cost of the UPS system inefficiencies is indicated above. At the maximum design load, the 9.12% losses result in a cost of £145,577 per annum to the operator.

4.4.4 Static double conversion UPS, operational and maintenance cost

The design of the data centre means it will not operate at 100% load, as the ‘2N’ redundancy configuration ensures it will only ever give a 50% loading as there will always be a minimum of 50% redundancy [80]. A lifecycle period of five years is envisaged from the initial capital investment, incorporating all maintenance, together with the operational costs which have been detailed in this chapter. For the first year, the facility has a capacity of 25% and reaching its full capacity of 1500 kW by year five. The main areas of costs for the double conversion static UPS includes the capital investment costs, maintenance requirements and operational cost. In addition, the cost of a generator integrated into the double conversion static UPS is also to ensure fair comparison (see Table 4.6).

Table 4.6: Double conversion static UPS operational and maintenance cost in 2N configuration

System	UPS Cost	Generator	Operational Cost	maintenance Cost
Static Double Conversion UPS	£626,359	£1,200,000	£7,728,740	£1,925,000

4.5 Flywheel UPS system based on 2N redundancy configuration

A percentage of data centre operators are opposed to the traditional Static UPS system with its requirement for a large battery capacity and have consequently embraced flywheel technology [120]. The flywheel technology performs as a ‘mechanical battery’ simply converting and storing electrical energy in the form of kinetic energy. The stored energy is used in the form of electrical power when it is required during a utility outage [119, 121]. The system that has been selected for this comparative study is a market leader in flywheel technology and has been successfully deployed in data centre applications [123,124]. The flywheel UPS system examined is based on a design in which a 1000 kVA system is composed of four 250 kVA flywheels. The power electronic losses are lower than those of the double conversion static system. Also, the additional air conditioning and battery room’s requirements for the Static UPS are not needed when using flywheel UPS system. The flywheel UPS investigated provides relatively high efficiency even at low loading. Table 4.7 clearly shows that the

flywheel UPS can achieve an efficiency of 91.3% at 20% load while in the Static UPS this level of efficiency is not gained until around 50% load. Figure 4.7 indicates the efficiency of this system along the complete spectrum of loads from 5% up to maximum capacity.

Table 4.7: 1000 kVA flywheel UPS efficiency from 5% up to maximum capacity

UPS Load	5%	10%	20%	30%	40%	50%	60%	70%	80%	90%	100%
Efficiency	53%	75.1%	91.3%	93.9%	95.3%	96.1%	96.6%	96.9%	97.3%	97.5%	97.6%

Figure 4.7, clearly indicates the efficiency of this system along the complete spectrum of loads from 5% up to maximum capacity and illustrate the efficiency curve.

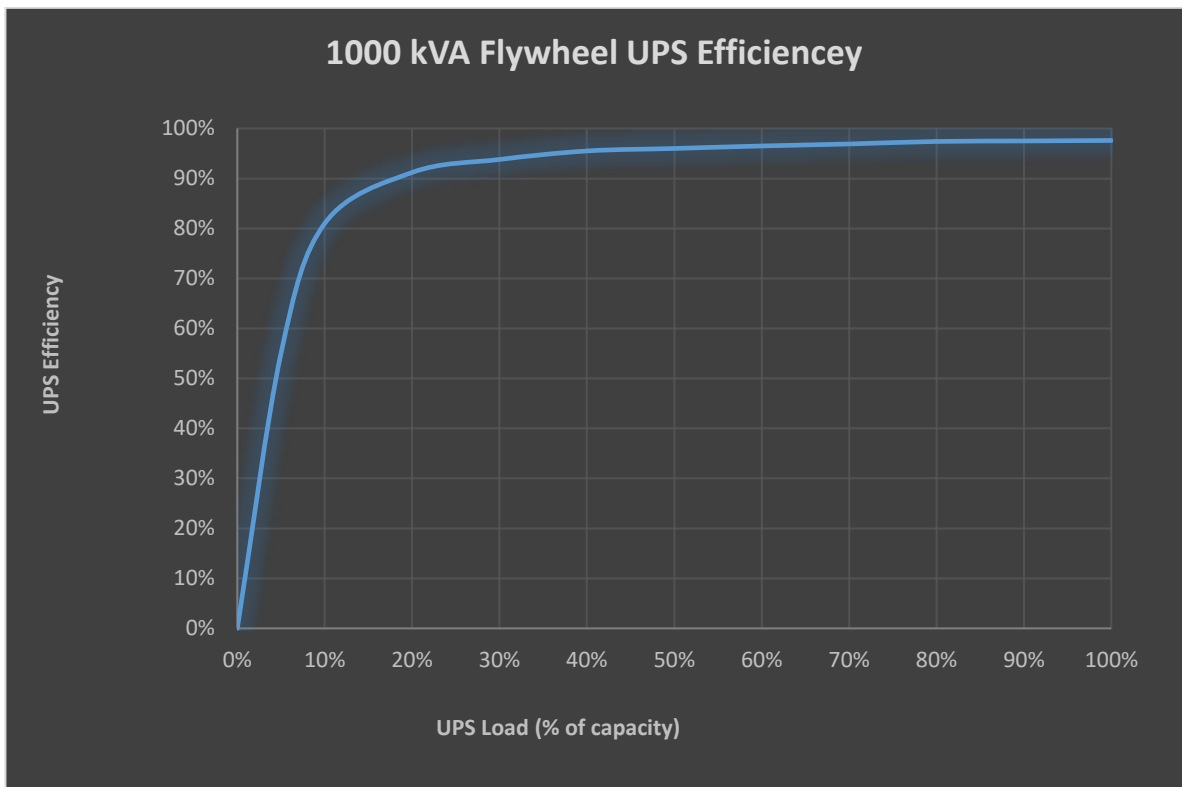

Figure 4.7: Flywheel UPS efficiency curve

Table 4.6 and Figure. 4.7, clearly indicates the efficiency of this system along the complete spectrum of loads from 5% up to maximum capacity. Considering a 2N redundancy configuration at maximum capacity.

4.5.1 '2N' Redundancy configuration for flywheel UPS system diagram

In this study the UPS requirements for the '2N' redundancy configuration design require two 1000 kVA, each 1000 kVA composed of four 250 kVA. So, eight UPS 250 kVA modules required, four UPS are paralleled on "A" side and another four UPS paralleled on side "B".

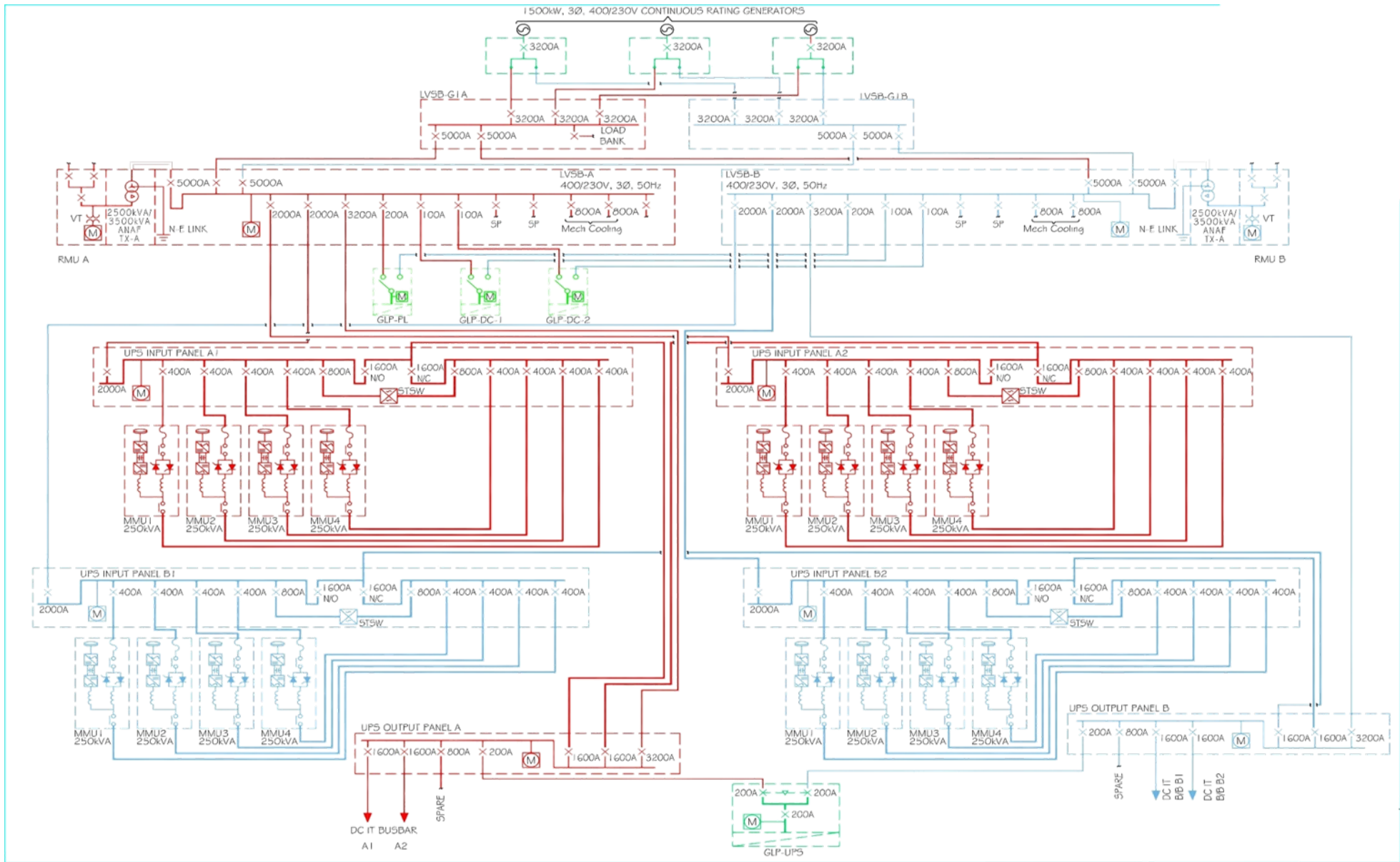

Figure 4.8: '2N' Redundancy configuration flywheel UPS diagram in a medium data centre

Table 4.8 details the output findings from the flywheel UPS System in ‘2N’ redundancy configuration based on calculations for a data centre designed to provide 1500 kW of IT load. The results in Table 4.8 have been measured across the complete spectrum of loading on the site to enable comparison between the alternative technologies.

Table 4.8: Flywheel UPS findings in 2N redundancy configuration

IT Load %	100%	75%	50%	25%
Load kW	1500	1125	750	375
PUE	1.20	1.26	1.36	1.76
UPS Load	45.8%	35.2%	24.6%	13.8%
UPS Efficiency	95.79%	94.68%	92.40%	81.50%
Impact on PUE	0.05	0.06	0.10	0.30
kWh	15,816,064	12,377,423	8,965,607	5,850,349
Cost [0.1 £/kWh]	£1,581,607	£1,237,743	£896,562	£585,036
UPS kWh	635,451	623,985	637,490	985,654
UPS Cost [0.1 £/kWh]	£63,545	£62,398	£63,749	£98,565

Figure 4.9, highlights the efficiency of this system along the complete spectrum of loads from 5% up to maximum capacity.

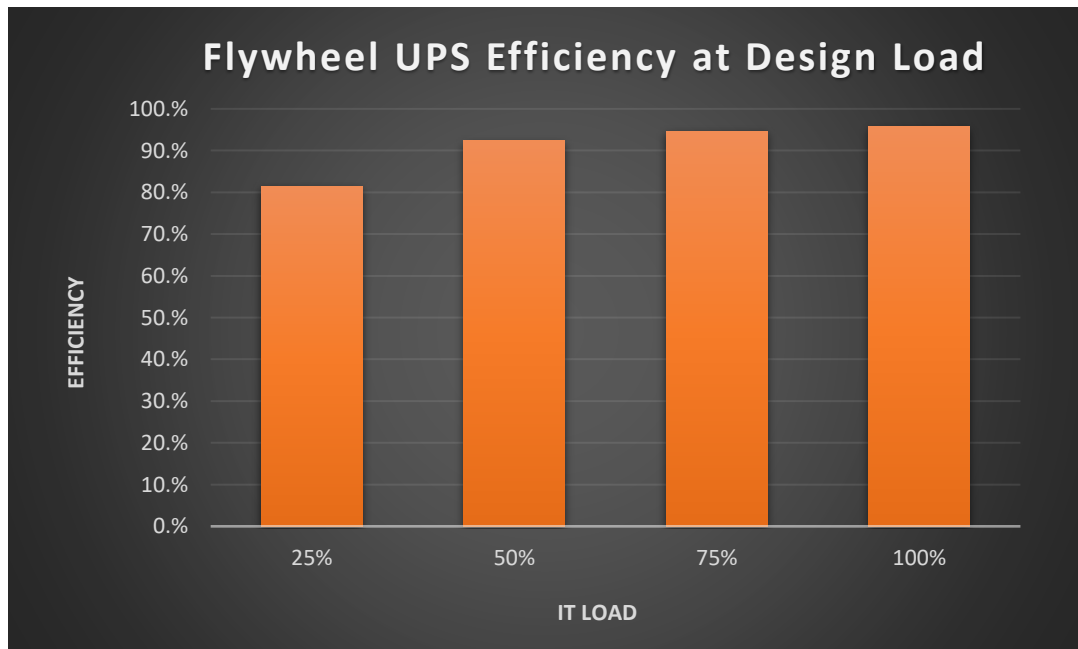

Figure 4.9: Flywheel UPS efficiency at design load

The 2N redundancy configuration 100% loading will only ever represent a 50% loading on the site UPS as there will always be a minimum of 50% redundancy [76]. The efficiency profile of the flywheel UPS is 92.40% efficiency at 50% IT load, because any system configured to operate with 100% redundancy can only ever achieve a peak loading of 50% if the load is balanced evenly across both distribution paths [125]. And that is an interesting where should result in energy savings.

4.5.2 The power usage effectiveness (PUE) of the 2N redundancy configuration flywheel UPS

Table 4.9 highlights the PUE for the data centre designed to provide 1500 kW of IT load, at various levels of IT load. Operating a flywheel UPS configured to 2N, the optimum PUE of the data centre is seen to be 1.2 at 100% (see Figure 4.10). This means that for every 1000 kW of power absorbed by the IT load, an additional 200 kW is required for the additional loads i.e. lighting, mechanical loads plus the inherent losses within the system.

Table 4.9: the PUE findings for the flywheel UPS in 2N redundancy configuration

IT Load %	100%	75%	50%	25%
PUE	1.2	1.27	1.36	1.8

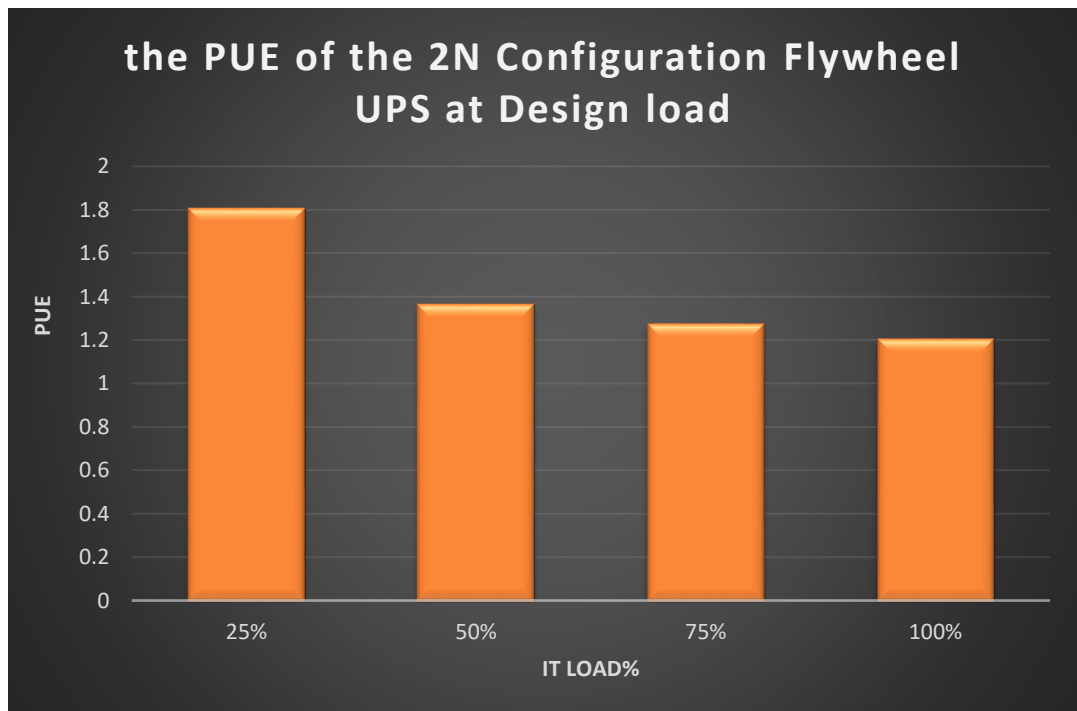

Figure 4.10: the PUE of the 2N configuration flywheel UPS at design load

4.5.3 The effect on the system cost

In this work, the cost calculation for the data centre energy is straight related to the absorbed power. At £0.10 per kWh. And the cost of the electricity calculated for one year of operation at 50% loading and recorded against site load ranging from 25% right up to 100%. The annualized cost of the UPS system inefficiencies is highlighted in Table 4.10. At maximum design load, it results in a cost of £63,545 per annum to the operator.

Table 4.10: Date centre energy and the flywheel UPS cost findings

IT Load %	100%	75%	50%	25%
kWh	15,816,064	12,377,423	8,965,607	5,850,349
Total Cost [0.1 £/kWh]	£1,581,607	£1,237,743	£896,562	£585,036
UPS kWh	635,451	623,985	637,490	985,654
Flywheel UPS Cost [0.1 £/kWh]	£63,545	£62,398	£63,749	£98,565

Analysing the graph in Figures 4.11 and 4.12, the annual energy costs for the facility have been calculated across a range of site loadings. Frome 25% to100% full load.

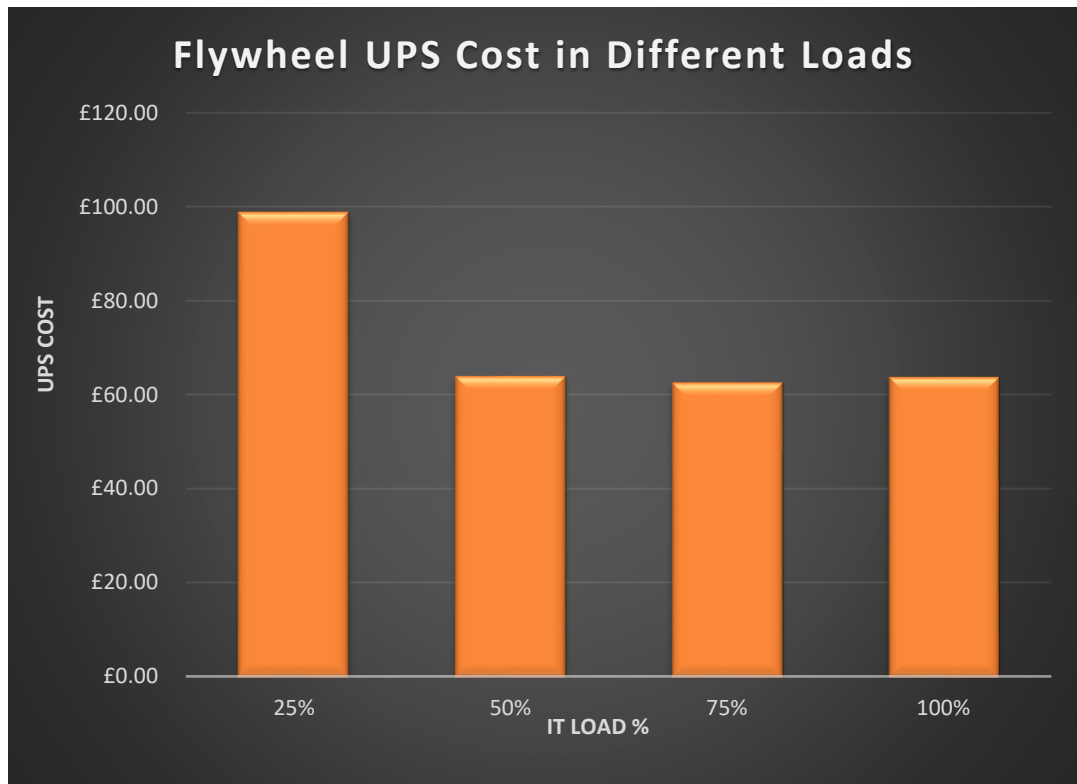

Figure 4.11: Flywheel UPS cost in different loads

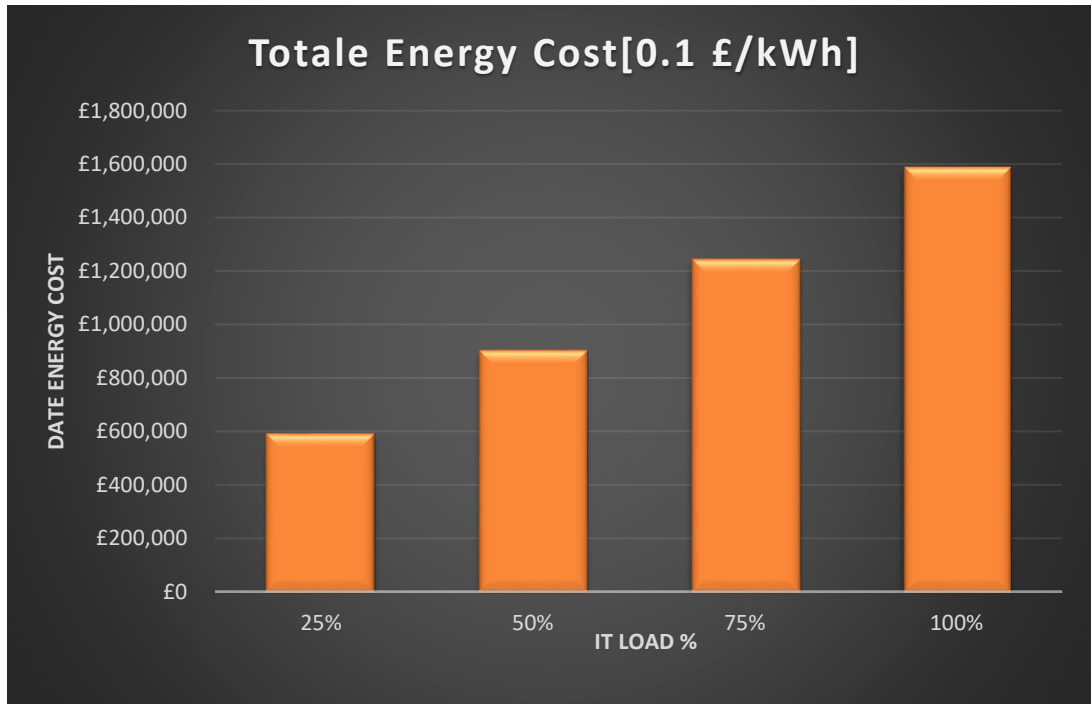

Figure 4.12: Total energy cost in different loads flywheel technology

Figures 4.11 and 4.12 highlight that operational expenses increase from 25% load (375 kW connected IT load) to 100%, when the facility is operating at the maximum design capacity. At maximum design load, the 7.12% losses result in an annual cost of £63.545, and reach £98,566 at 25% loading. The total energy cost reaches £1,581,607 at 100% loading.

4.5.4 Flywheel UPS technology, operational and maintenance cost

In this study where the data centre has been designed will not operate at 100% load from day one. Also, the 2N redundancy configuration 100% loading will only ever represent a 50% loading on the site UPS as there will always be a minimum of 50% redundancy [4]- [5]. A lifecycle period of five years has been captured based on the initial capital investment, along with all the maintenance and operational costs which have been detailed in this chapter. For the first year, the facility is considered to have a capacity of 25% and reaches its full capacity of 1500kW by year five. The UPS costs for the data centre designed capacity of 1500kW IT load plus supporting infrastructure are detailed in Table 4.11. Also, the cost of the generator integrated into the flywheel UPS technology is included to allow fair comparison.

Table 4.11: Flywheel UPS technology operational and maintenance cost in 2N configuration

System	UPS Cost	Generator	Operational Cost	maintenance Cost
Flywheel UPS Technology	£585,036	£1,200,000	£7,522,125	£1,815,000

4.6 Comparative analysis of the double conversion and flywheel UPS based on '2N' configuration

The following sections compare, the flywheel UPS and double conversion static UPSs in terms of efficiency, PUE and cost based on 2N configuration.

4.6.1 Efficiency comparison of the two UPS technology based on '2N' redundancy configuration

The calculations in '2N' redundancy configuration UPS efficiency show that at 50% capacity the efficiency of flywheel technology is 92.4%, whereas the double conversion static UPS is only 85.1%. Furthermore, the efficiency of flywheel technology at 100% capacity is 95.7%, whereas the double conversion static UPS only achieves 90.8% (see Figure. 4.13). Thus, the flywheel UPS is more efficient than the Static type for the '2N' redundancy configuration.

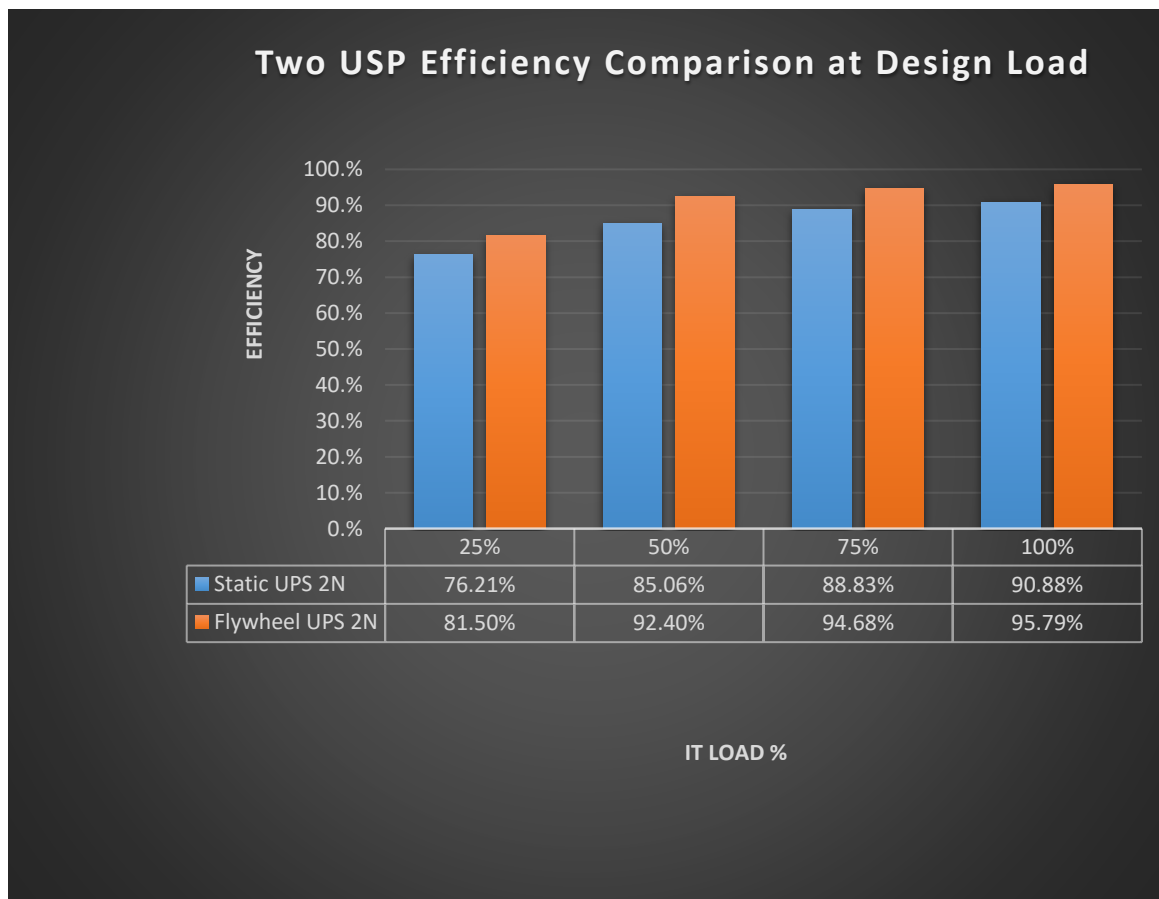

Figure 4.13: Two UPS efficiency comparison at design loads

4.6.2 Power usage effectiveness comparison of the Two UPS based on ‘2N’ redundancy configuration

The data in Figure 4.14, highlights the PUE of the flywheel and static UPS for the designed data centre. The results illustrate that the flywheel technology achieves the lower PUE across all levels of electrical loading. The optimal PUE achieved in ‘2N’ architecture was by the flywheel system operating at maximum load, achieving a PUE of 1.23.

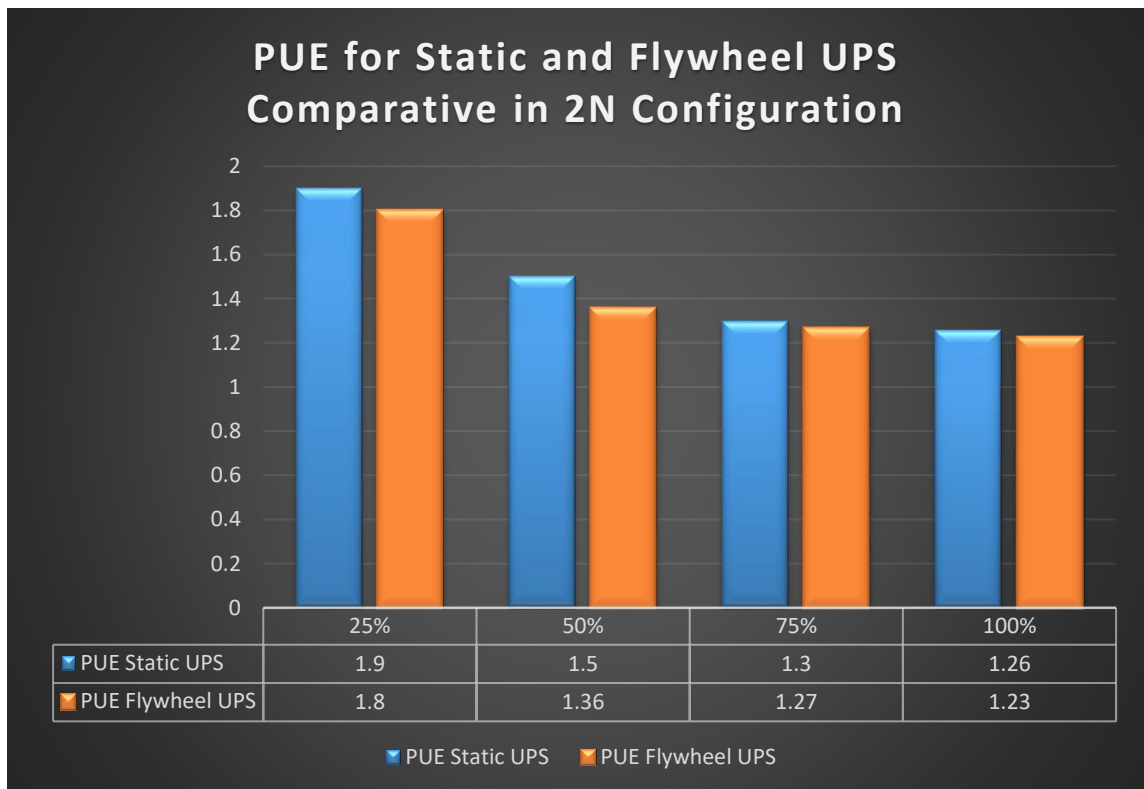

Figure 4.14: PUE for static and flywheel UPS comparative in 2N configuration

4.6.3 Cost comparison of the two UPS technology based on ‘2N’ redundancy configuration

The operational costs of the 1500 kW data centre designed using the two UPS technology types and all configured to 2N redundancy configuration. These cost calculations are a direct function of the energy use analysis for every unit of electricity take in has a cost. The annual cost of operating the facility at half of its designed capacity. In this work, the cost calculation for the data centre energy is straight related to the absorbed power. At £0.10 per kWh. And

the cost of the electricity calculated for one year of operation at 50% loading and recorded against site load ranging from 25% right up to 100%.

Figures 4.15 and 4.16, reveal the predicted operational costs for the two UPS technology types and the impact of the UPS on overall energy costs in relation to the designed data centre. The annual energy costs for the facility have been calculated across a range of site loadings. For the flywheel at 100% loading the UPS costs £63.545, and reaches £98.566 at 25% loading, whereas the double conversion static UPS costs £145.676 and reaches £136.322 at 25% loading.

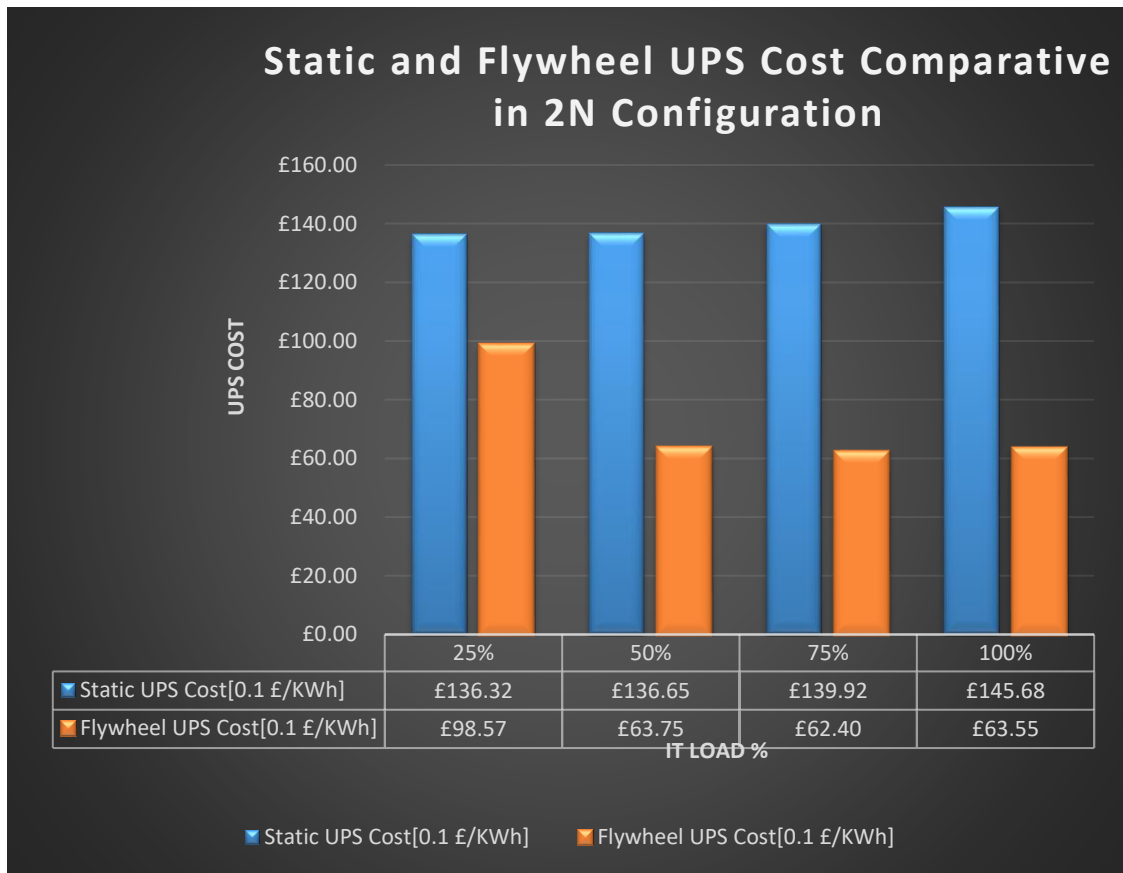

Figure 4.15: Static and flywheel UPS cost comparative in 2N configuration

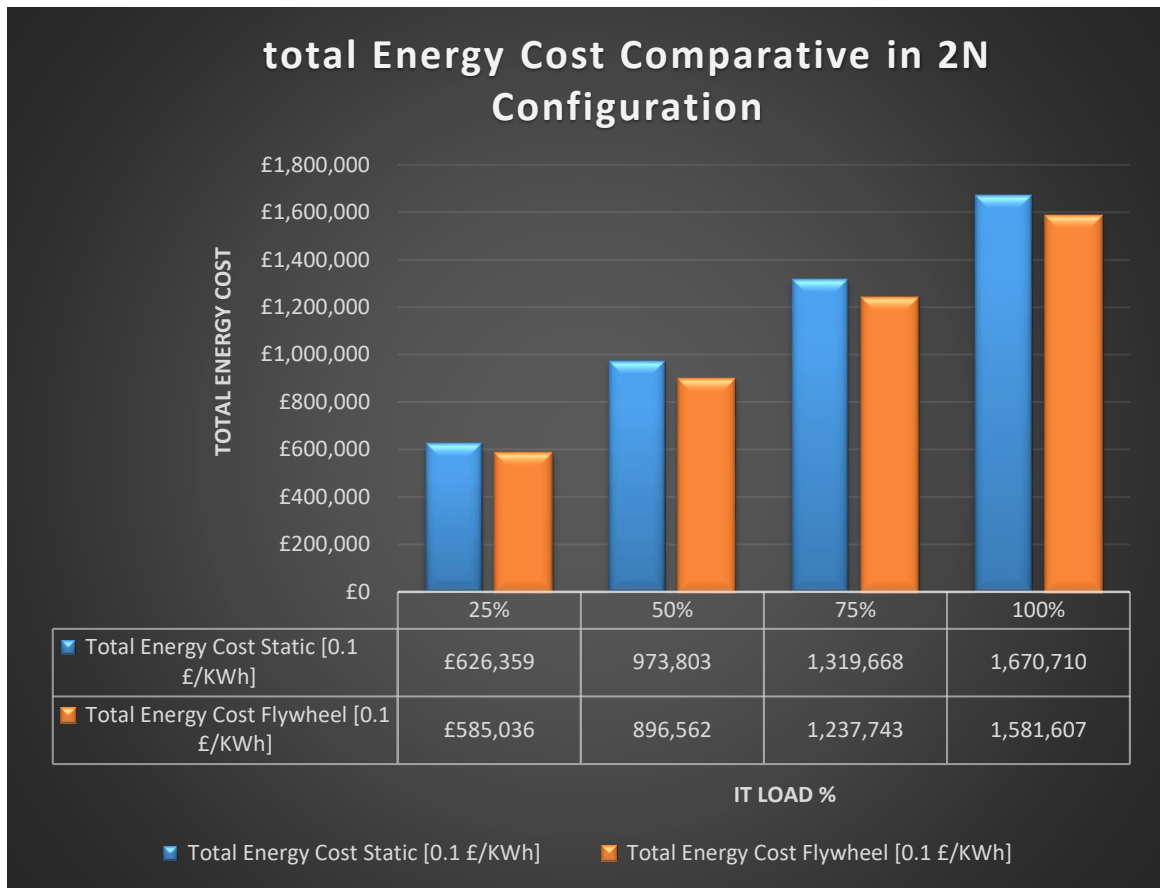

Figure 4.16: Total energy cost comparative in 2N configuration for two UPS technology

4.7 Summary

The subject of efficiency had always played an important role in data centre and UPS systems. Data centre energy efficiency is a significant and growing concern for operators, utilities and policy makers. Inefficient UPS systems can contribute to this concern with 10 to 15 percent or more of utility input going to electrical waste within the UPS itself. Flywheel based on ‘2N’ redundancy configuration, can be part of the solution. Proven in this study, shows that at 50% capacity the efficiency of the flywheel technology is 92.4%. Whereas the double conversion static UPS only achieves 85.1%, and the efficiency of flywheel technology at 100% capacity is 95.7%, whereas the double conversion static UPS only achieves 90.8% at 100% capacity load.

Another important aspect in the choice of a flywheel is its costs. By means of calculations it is easy to verify that, taken over the year, a flywheel UPS is more economical than a double conversion static UPS. The main reasons for this are the low maintenance costs and the long service life of the flywheel compared to the double conversion UPS, which more than balances out the higher acquisition costs at the start of installation. Whereas a flywheel UPS,

usually has the same service life as the UPS system, battery installations should be replaced several times during the service life of a UPS. This study reveals, that flywheel based UPS systems, provide dramatically better efficiency across the board than conventional double-conversion UPS with batteries, based mainly on the two-step process of converting utility power from AC to DC, and then from DC to AC. This higher efficiency meets the quality power target.

Chapter 5: : DESIGN DESCRIPTION FOR N+1 REDUNDANCY CONFIGURATION

5.1 Introduction

The main UPS preferred choices for protecting critical loads in data centre are, double conversion UPS and flywheel UPS system [50]. But for the data centre managers and operators selecting the right UPS for deployment can be a difficult proposition. Therefore, this research seeks to conduct a more empirical investigation. By doing a series studies, simulations and calculations in an electrical model for a medium size data centre is designed to provide 1500 kW to IT load based on 2N and N+1 configuration. The study will be undertaken to determine which UPS technology and topology can improve data centre energy efficiency and reduce the cost.

In order to clear these concerns, a comparison made between the most preferred choices of the UPS technologies deployed in data centres, double conversion online UPS and flywheel UPS system, in a model of a medium size data centre designed to provide 1500 kW of cooling capacity to the data halls and hence support the IT load. The electrical infrastructure topology to be adopted is 'N+1' parallel redundancy configuration for each type of the UPS systems technologies. Where 'N' can simply be defined as the number of UPS modules that are required to supply power to IT load. In other words, the minimum backup protection required feeding the critical load. 'N+1' configuration mean there is one or more UPS module than needed and work together to supply power to the IT load and connected to share the load equally as a conjoined system, each UPS stands ready to take over the load from another UPS whenever necessary, without disrupting protected loads [76]. Also, the entire critical load will be less than half of the total UPS capacity installed. The system shall be designed in accordance with the Uptime Institute Tier III requirements [31, 32]. Computer based software programs such as the "Romonet" is used to offer Predictive Modelling Tool for data centre in order to evaluate how a data centre would operate under different conditions, then a full analysis of the system is carried out.

It is one method used to ensure system availability in the event of component or power failures. In engineering terms, it is "the duplication of critical components or functions of a system with the intention of increasing reliability of the system, usually in the case of a backup. In data centres, it is the total number of necessary power equipment + 1 extra backup power supply to ensure uninterruptible power supplies. on other words, there would be sufficient spare capacity to support the load if any one module became unavailable [76].

5.2 Double conversion UPS system calculation based on N+1 redundancy configuration

Double conversion UPS systems deliver power to connected equipment in a two steps process. First they convert incoming AC power to DC power, then they convert the DC power to conditioned AC power with a pure sine wave [1]. During normal or even abnormal line conditions, the inverter supplies energy from the mains through the rectifier, which charges the batteries continuously, when the AC-input supply voltage goes outside UPS present tolerances or fails, the inverter and battery continue to support load power. Also, the UPS have the bypass switch connects the load directly to the utility mains, in order to guarantee the continuous supply of the load, avoiding damage to the UPS module which called bypass operation. So, a double conversion on-line UPS typically has at least three power conversion stages [61]. The efficiency of the static UPS has been derived measuring the UPS losses in double conversion mode, based on an 1100 kVA system which the data centre in this study has been designed around. As shown in Figure 5.1, higher efficiency could be achieved with the static UPS by operating it in Eco mode where a 6-10% improvement in system efficiency could be achieved.

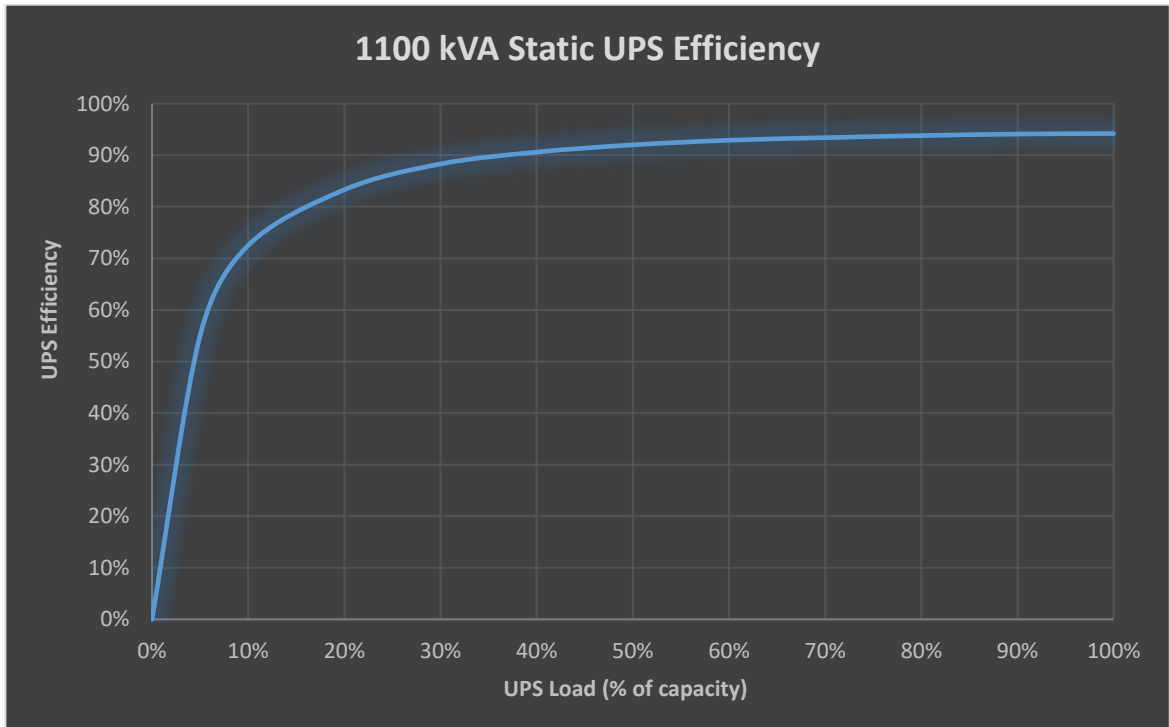

Figure 5.1: Static UPS efficiency curve

5.2.1 'N+1' Redundancy configuration for static UPS system diagram

In N+1 redundancy, the UPS is being used to only 50% of its efficiency. In normal situations, you can push it to 75%. The part load efficiency of any system is always inferior to its full load efficiency. Thus, one of the challenges is to improve part load efficiency. During normal operations, the load is shared equally across all modules, which behave as if they were a single large UPS device. If a single module fails or needs to be taken offline for service, the UPS system will still be able to provide an adequate supply of power because it's already been configured with one extra module [76].

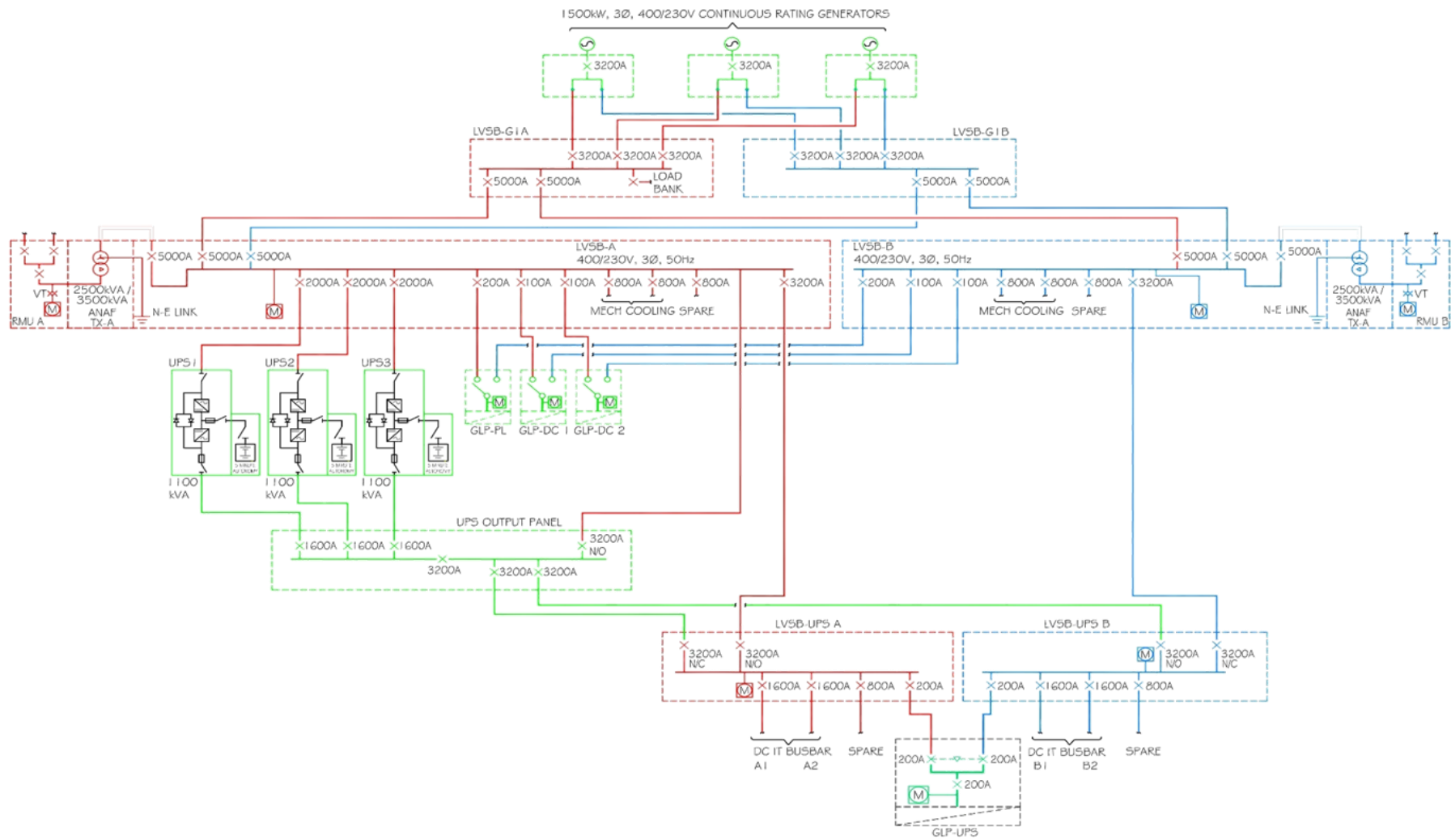

Figure 5.2: 'N+1' Redundancy configuration static UPS diagram in a medium data centre

In this study, (see Figure 5.2). The electrical infrastructure topology N+1 redundancy configuration for a medium size data centre designed to provide 1500 kW to support the IT load. In this case, to protect 1500 kW load will deploy three 1100 kVA UPS modules. During normal operation, the three modules would each carry one-third of the total 1500 kW load. If one module fails, the remaining two UPS modules stand ready to take the action over the load from another UPS and have sufficient capacity to support protected load. Parallel redundant configuration improves availability and allows UPS modules to be serviced without effect the power quality of the connected load.

Considering a N+1 redundancy configuration at maximum capacity, this will essentially be reflected as 50% loading on the UPS at maximum capacity which would result in losses of 8% on this Static UPS. To overcome this event of large heat losses due to double power conversion at low loading, modular UPS systems such as this 1100 kVA system studied can operate a UPS module management programmed where if the load is only 100 kVA, only two of the three 225 kVA UPS modules will run in double conversion with the other modules switching to double conversion immediately, only if there is a load increase or power disturbance experienced.

The system selected is scalable in blocks of 275 kVA up to a maximum of 1100 kVA; the UPS requirements for the design to be adopted here require 3 UPS. 1100 kVA modules paralleled together on both A and B strings for the ‘N+1’ configuration. Table 5.1, details all of the outputs finding from static UPS system (double conversion type) in ‘N+1’ redundancy configuration system and the calculations undertaken for the data centre designed to provide 1500 kW of IT load.

Table 5.1: Static UPS findings in N+1 redundancy configuration

IT Load %	100%	75%	50%	25%
Load kW	1500	1125	750	375
PUE	1.25	1.31	1.43	1.80
UPS Load	41.8%	32.1%	22.4%	12.6%
UPS Efficiency	92.52%	91.03%	88.32%	81.15%
Impact on PUE	0.11	0.14	0.21	0.41
kWh	16,415,606	12,883,418	9,392,286	5,902,586
Cost [0.1 £/kWh]	£1,641,560	£1,288,341	£939,229	£590,259
UPS kWh	1,172,817	1,096,455	1,027,860	1,013,724
UPS cost [0.1£/kWh]	£117,282	£109,645	£102,786	£101,372

Table 5.1, details all the outputs from the calculations undertaken for data centre providing 1500 kW of IT load in a N+1 redundancy configuration. The 3 UPS 1100 kVA UPS modules are configured on one string ultimately feeding two UPS output switchboards. The results in the table above are recorded against site load ranging from 25% right up to 100%. The design has three 1100 kVA UPS modules operating in parallel and any one of these provides (+1) redundancy [76]. With the increased loading on the UPS system, increased efficiency would be anticipated with a reduction in system losses. The graph in Figure 5.3, indicates how the system achieves 81.15% at 25% load and reaches 92.52% when the facility reaches maximum capacity. In terms maximizing efficiency, at a partial load of only 25%, the UPS system inefficiencies result in a cost of £101,372 to the Operator, in terms of financial outlay, this value remains constant from low load up to peak load. However, the IT load increases from 375 kW to 1500 kW over this period, and the Table 5.1, above indicates this monetary value is a much larger per cent age of the overall costs at low load than peak load.

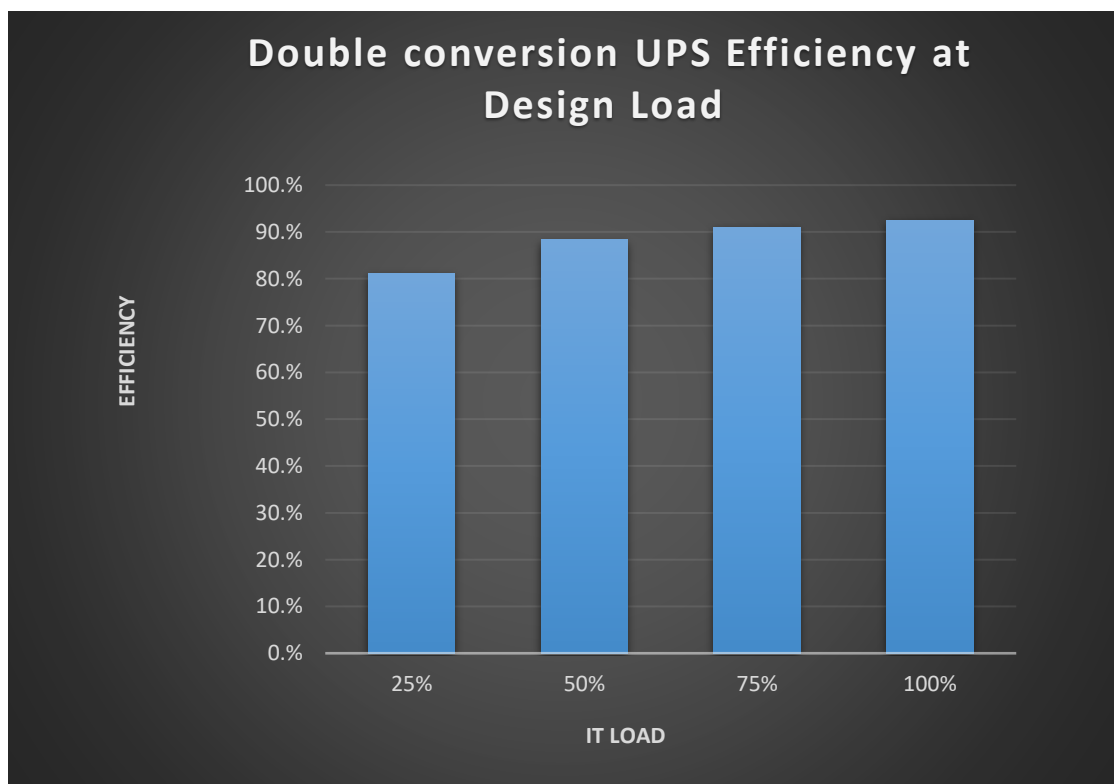

Figure 5.3: Double conversion static UPS efficiency at design load

5.2.2 The power usage effectiveness of the N+1 redundancy configuration static UPS

As mentioned in previous chapter, a common metric used to determine the energy efficiency of a data centre is the ratio of the total power entering the data centre divided by the power used by the IT equipment [25]. The PUE is presented as a fraction whereby the total facility power inclusive of all losses is divided by the power consumed by the data centre IT equipment. (see Table 5.2). The power usage effectiveness of the N+1 redundancy configuration static UPS and the calculations undertaken for the data centre designed to provide 1500 kW of IT load.

Table 5.2: the PUE findings for the static UPS in N+1 redundancy configuration

IT Load %	100%	75%	50%	25%
PUE	1.25	1.31	1.43	1.80

Figure 5.4, represents the PUE for the data centre at various levels of IT load as the total facility power inclusive of all losses is divided by the power consumed by the Data Centre IT equipment. Clearly that this metric obtains closer to one at the maximum load 100%.

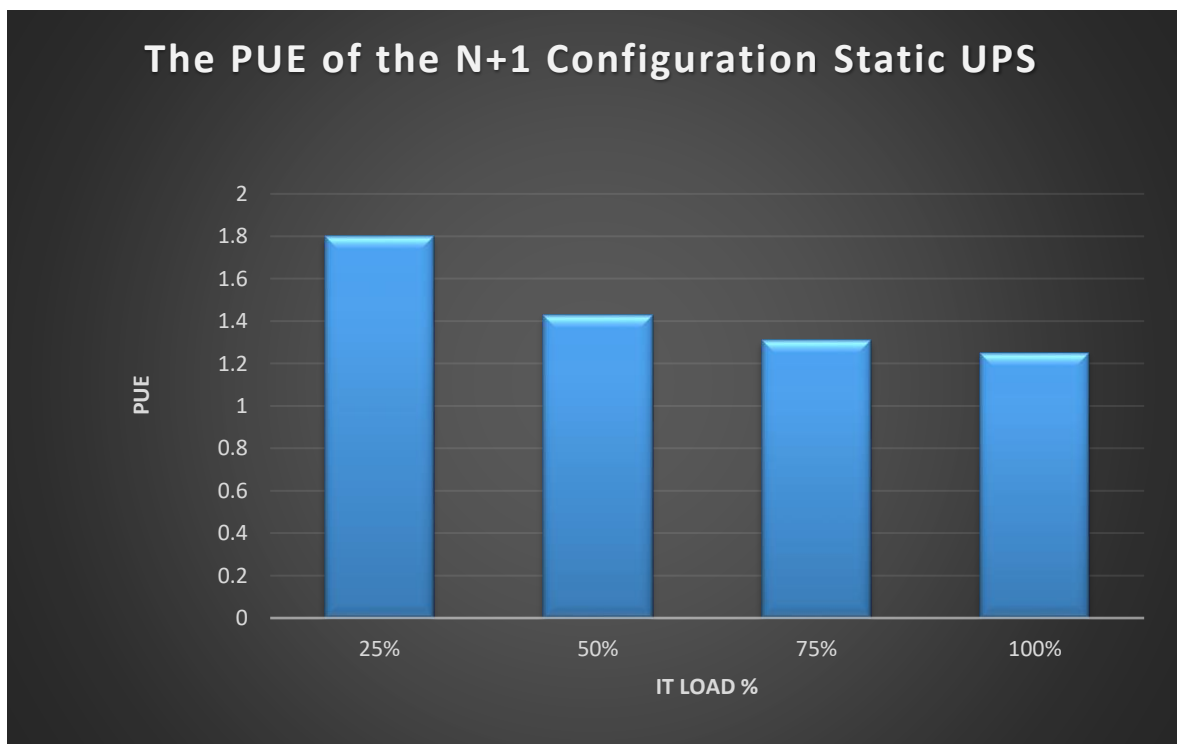

Figure 5.4: the PUE of the N+1 configuration static UPS at design load

5.2.3 The effect on system cost

Clarify the data centre energy cost and the impact of the UPS on overall energy costs. Help data centre managers and operators, with a clearer understanding of key factors and considerations involved in selecting the right UPS system in terms cost. In this work, the cost calculation for the data centre energy is straight related to the absorbed power. At £0.10 per kWh. And the cost of the electricity calculated for one year of operation at 50% loading and recorded against site load ranging from 25% right up to 100%. So, the cost calculation for the data centre energy and the UPS as seen in Table 5.3.

Table 5.3: the data centre energy and the static UPS cost findings N+1 configuration

IT Load %	100%	75%	50%	25%
kWh	16,415,606	12,883,418	9,392,286	5,902,586
Total Cost [0.1 £/kWh]	£1,641,560	£1,288,341	£939,229	£590,259
UPS kWh	1,172,817	1,096,455	1,027,860	1,013,724
Static UPS Cost [0.1 £/kWh]	£117,282	£109,645	£102,786	£101,372

In terms maximising efficiency. At a part load of only 25%, the UPS system inefficiencies result in a cost of £101,372 to the operator. In terms of monetary expense, this value remains constant from low load up to full load. Nevertheless, the IT load increases from 375 kW up to maximum load over this period. The graph in Figure 5.5, indicates this financial value is a much larger per cent age of the overall costs at low load than peak load.

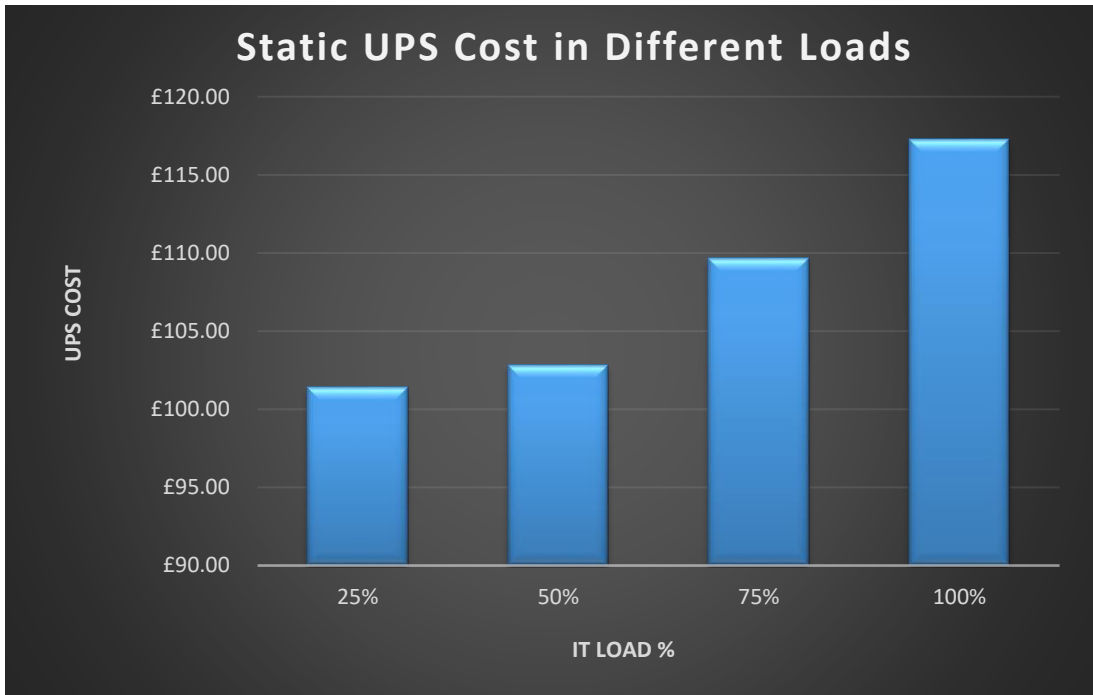

Figure 5.5: Static UPS cost in different loads N+1 configuration

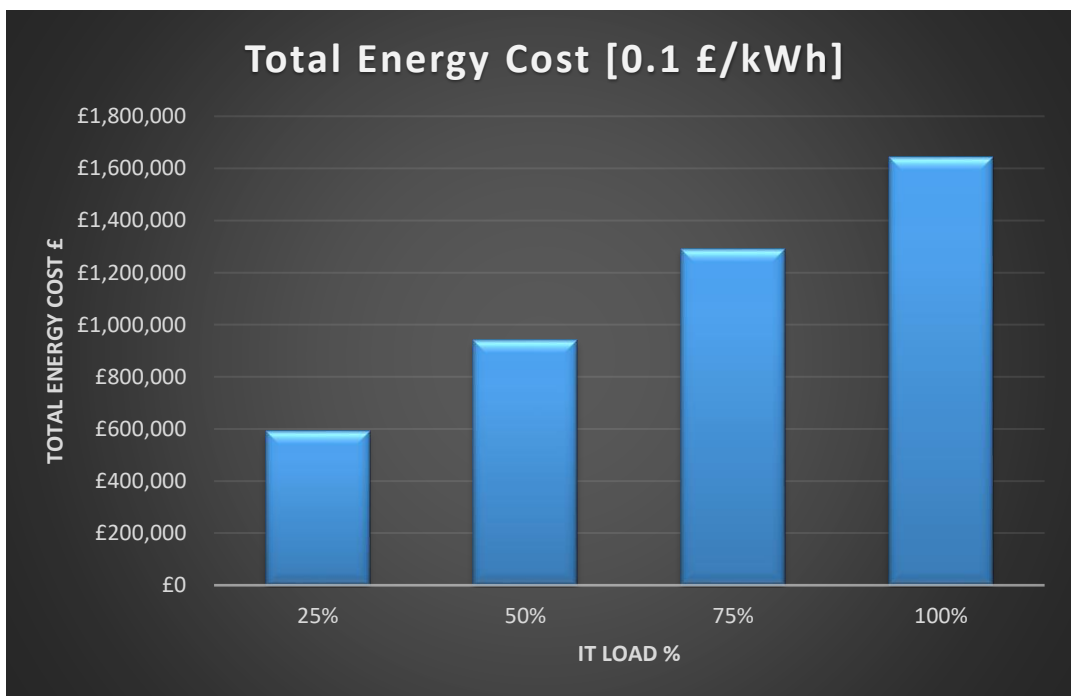

Figure 5.6: Total energy cost in different loads static technology

The net effect of framework inefficiencies and resultant high data centre PUE will be expanded operational expenses. The effect of the N+1 Configuration Static UPS at Design load has on the overall cost is delineated in Table 5.5 and Figure 5.6, justifiably operational

expenses are seen to increase from 25% load (375 kW connected IT load) to 100%, facility operating at maximum design capacity. The annualized cost of the UPS system inefficiencies is indicated below. This has a considerable effect on overall energy costs. At maximum design load, the 9.12% losses result in a cost of £117,282 per annum to the Operator.

5.3 Flywheel UPS system calculation based on N+1 redundancy configuration

The system that has been selected for study in this comparative analysis is a market leader in the flywheel technology which has been successfully deployed in data centre applications. The flywheel UPS system examined in this study is based on a design whereby a 1000 kVA system is composed of 4 no 250 kVA flywheels. Comparing with the power electronics losses associated with the double conversion Static System are absent and the additional air conditioning requirements for Static UPS and battery rooms. When using flywheel UPS system, the flywheel UPS investigated provided relatively high efficiency even at low loading. Figure. 5.7, clearly indicate that the flywheel UPS can achieve an efficiency of 91.2% at 20% load. Where in double conversion can achieve an efficiency of 92% at 50% load.

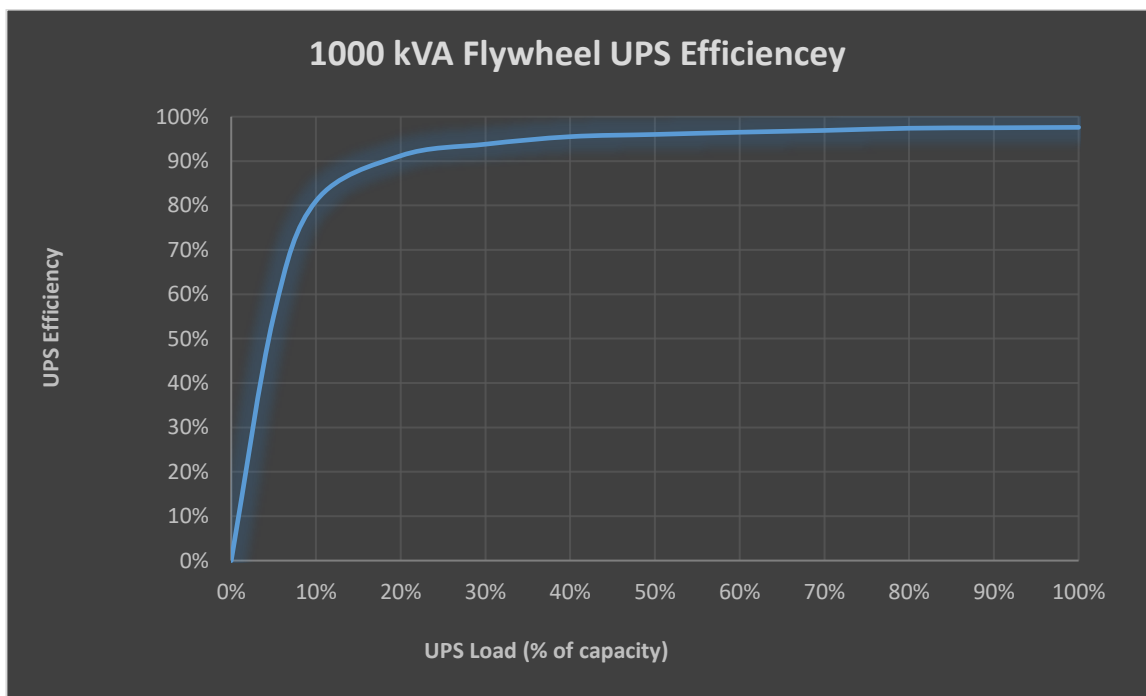

Figure 5.7: Flywheel UPS efficiency curve

5.3.1 'N+1' Redundancy configuration for flywheel UPS system diagram

In an N+1 configuration, one of the power stages operates differently from the others. If all the power stages of an N+1 system operated identically, the UPS would behave like a higher capacity UPS module operating at reduced load. Reactive current would have to be supplied through all N+1 line inductors to regulate load voltage. The redundant flywheel is charged like the others using power from the output power bus rather than through its own static disconnect switch and line inductor [111].

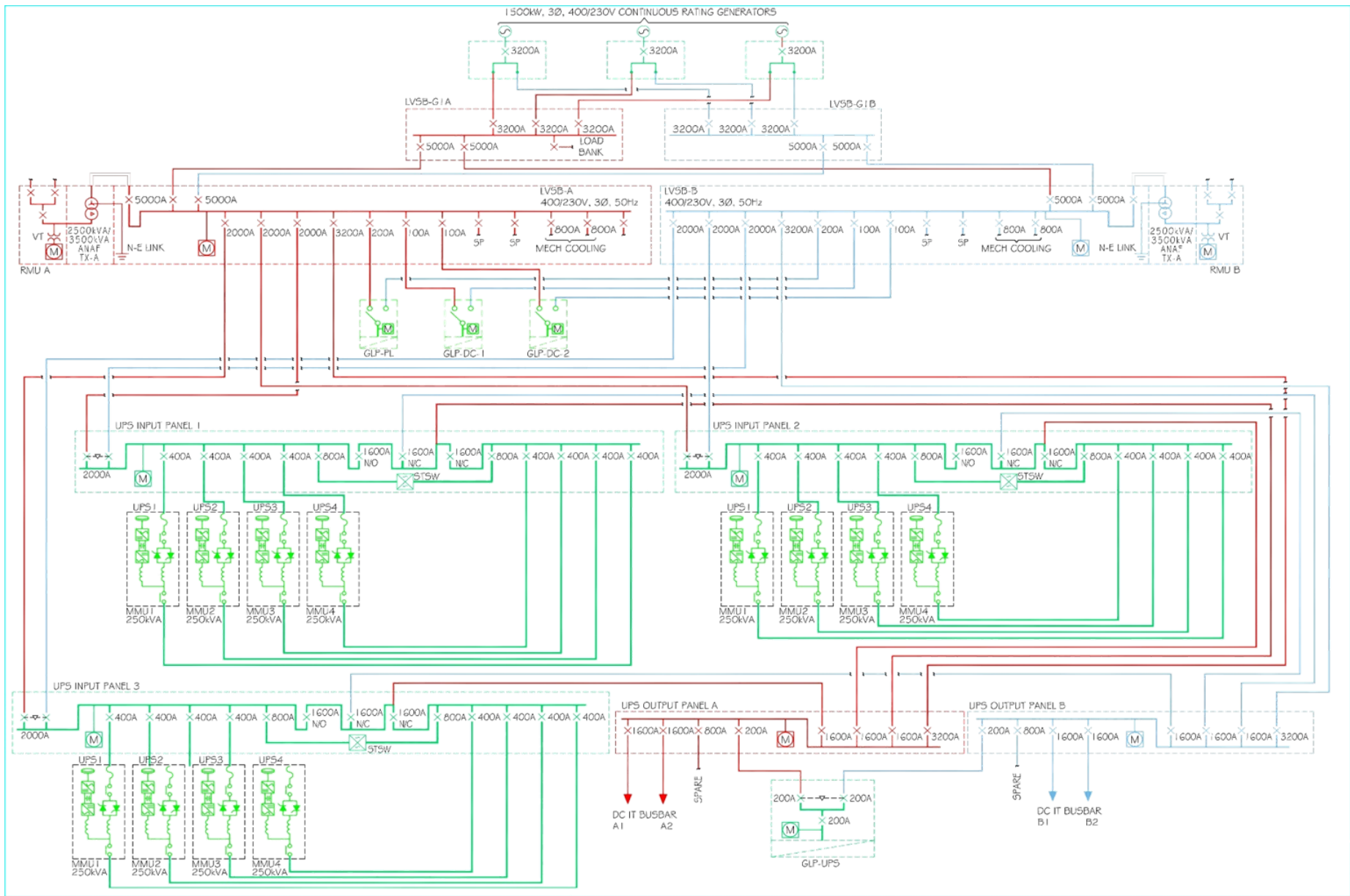

Figure 5.8: 'N+1' Redundancy configuration flywheel UPS diagram in a medium data centre

In this study ‘N+1’ redundancy configuration the three 1000 kVA UPS in N+1 design is composed of a total of 12 UPS 250 kVA modules integrated to provide the required levels of redundancy. As detailed on the system diagrams the flywheel technology has been coupled with a system of continuous rated generators protecting the data centre IT and critical cooling loads from both short power disturbances and any extended power outages. Table 5.4, details all the outputs finding from flywheel UPS System in ‘N+1’ redundancy configuration and the calculations undertaken for the data centre designed to provide 1500 kW of IT load.

Table 5.4: Flywheel UPS findings in N+1 redundancy configuration

IT Load %	100%	75%	50%	25%
Load kW	1500	1125	750	375
PUE	1.19	1.24	1.34	1.63
UPS Load	61.1%	47.0%	32.8%	18.4%
UPS Efficiency	96.52%	95.85%	94.28%	89.63%
Impact on PUE	0.11	0.14	0.21	0.41
kWh	15,648,855	12,230,205	8,793,146	5,348,434
Cost [0.1 £/kWh]	£1,569,886	£1,223,020	£879,315	£534,843
UPS kWh	521,293	480,821	470,220	502,386
UPS Cost [0.1 £/kWh]	£52,129	£48,082	£47,022	£50,239

Table 5.4, summarizes the results for the data centre operating at the same load levels but the UPS parameters are those of the flywheel. The calculations have been carried out initially on a ‘N+1’ redundancy configuration. The results in Table 5.4 have been measured across the complete spectrum of loading on the site to enable comparison with the alternative technologies, for the data centre operating a N+1 flywheel UPS system. The total electricity costs apportioned to data centre operations in this topology range from £534,843 at a quarter of the designed capacity to £1,569,886 at full load. The impact the UPS has on the overall costs remained at approximately £50,000 irrespective of site loading. Figure 5.9, clearly indicates that configuring the flywheel UPS in a N+1 Architecture has a definite positive impact on the efficiency, in the graph below the UPS system is seen to achieve 89.6% as low as 25% site IT load. The efficiency of this system along the complete spectrum of loads from 5% up to maximum capacity and illustrate the efficiency.

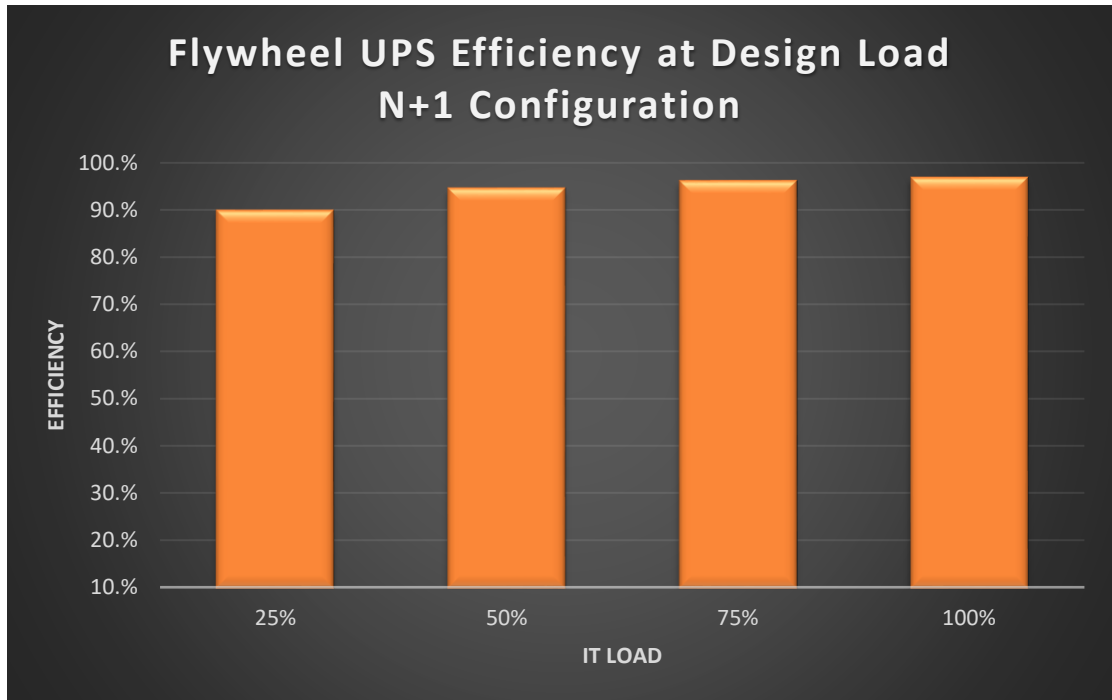

Figure 5.9: Flywheel UPS efficiency at design load

The flywheel UPS efficiencies on ‘N+1’ redundancy configuration at part load. The efficiency profile of the flywheel UPS achieving 94.28% efficiency at 50% IT load, because any system configured to operate with 100% redundancy can only ever achieve a peak loading of 50% if the load is balanced evenly across both distribution paths [8-9]. And that is an interesting where should result in energy savings. (see Figure 5.9).

5.3.2 The power usage effectiveness (PUE) of the N+1 redundancy configuration flywheel UPS

Table 5.5 and Figure 5.10, represents the PUE for the data centre designed to provide 1500 kW of IT load, at various levels of IT load as the total facility power inclusive of all losses is divided by the power consumed by the data centre IT equipment.

Table 5.5: the PUE findings for the flywheel UPS in N+1 redundancy configuration

IT Load %	100%	75%	50%	25%
PUE	1.19	1.24	1.34	1.63

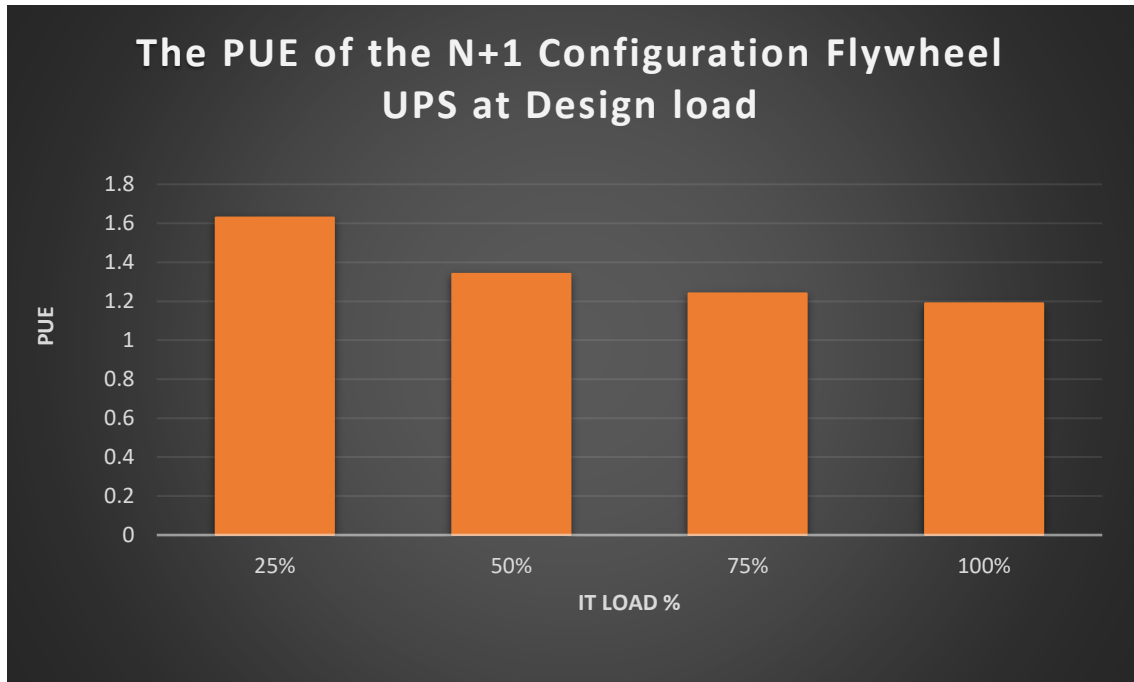

Figure 5.10: the PUE of the N+1 configuration flywheel UPS at design load

5.3.3 The effect on the system cost

The UPS and the data energy total cost, are documented in Table 5.6, the impact of the UPS has on the overall costs remained at approximately £50,000 regardless of site loading, for the data centre operating a N+1 redundancy configuration flywheel UPS system.

Table 5.6: The effect on flywheel UPS cost findings in N+1 configuration

IT Load %	100%	75%	50%	25%
kWh	15,648,855	12,230,205	8,793,146	5,348,434
Total Cost [0.1 £/kWh]	£1,569,886	£1,223,020	£879,315	£534,843
UPS kWh	521,239	480,821	470,220	462,386
Static UPS Cost [0.1 £/kWh]	£52,129	£48,082	£47,022	£46,239

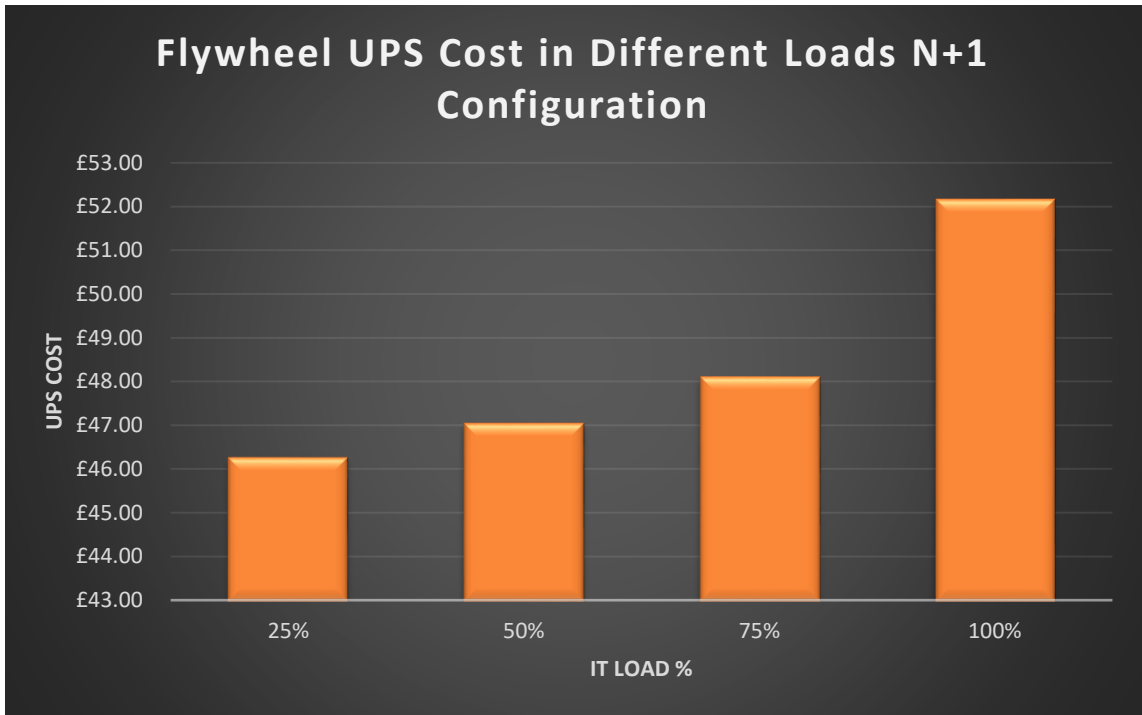

Figure 5.11: Flywheel UPS cost in different loads N+1 configuration

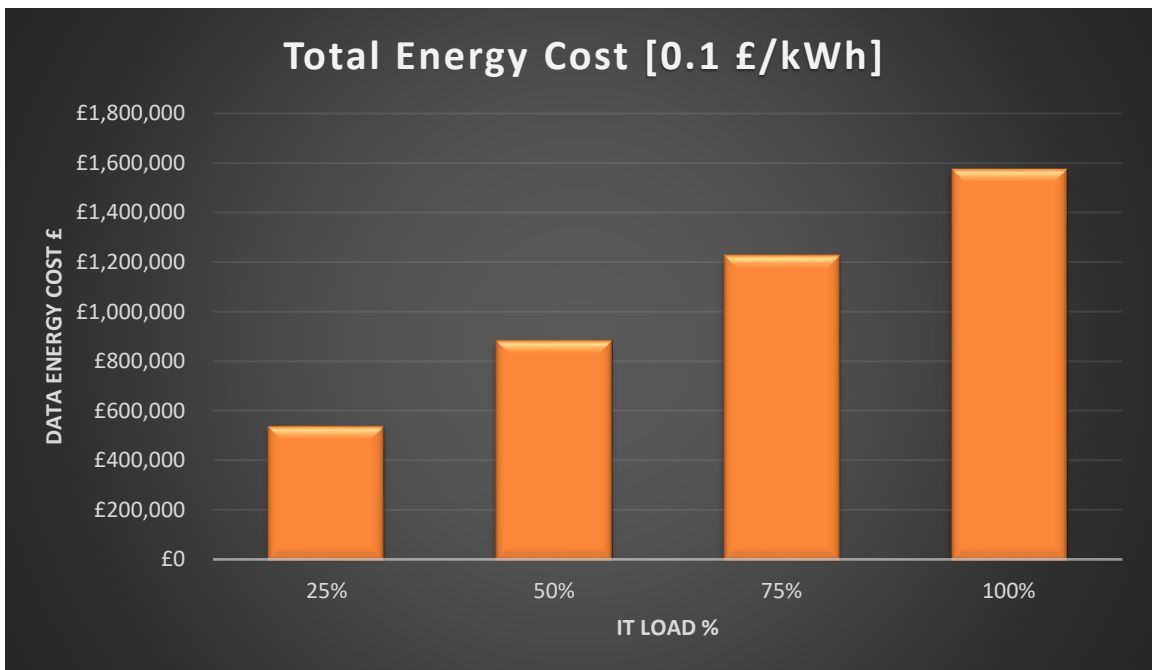

Figure 5.12: Total energy cost in different loads flywheel technology

The expected higher cost of the UPS low load losses is effectively cancelled out by the increased losses of the UPS operating at peak loading. The UPS is seen to be less efficient at low load but the cost to the operator of the actual UPS losses does not change across the

spectrum of loadings. The system is definitely more efficient at high load but for the higher output, a measurable % increase in losses is recorded.

5.4 Comparative analysis of the static and flywheel ups for ‘N+1’ redundancy configuration

The following sections compare the flywheel UPS and double conversion static UPS in terms of efficiency, PUE and cost based on N+1 configuration.

5.4.1 Two UPS technology efficiency comparison ‘N+1’ redundancy configuration

Considering both the flywheel UPSs and double conversion static UPSs used in the data centre. The studies and calculations in ‘N+1’ redundancy configuration UPS efficiency for both technologies types, shows at 50% capacity that the efficiency of the flywheel technology can reach 92.4%, and costs of the UPS [0.1 £/kWH] is £47.022. Whereas the double-conversion Static UPS only reaches 85.1% and costs of the UPS [0.1 £/kWH] is £102.786 as in Figure 5.13 shows. The Double-conversion system’s low efficiency compared with the flywheel UPS, which means that flywheel type is more efficient than the Static type for the ‘N+1’ redundancy configuration, but a more critical analysis for other configuration taking into account future development in data centre shows slightly different scenario.

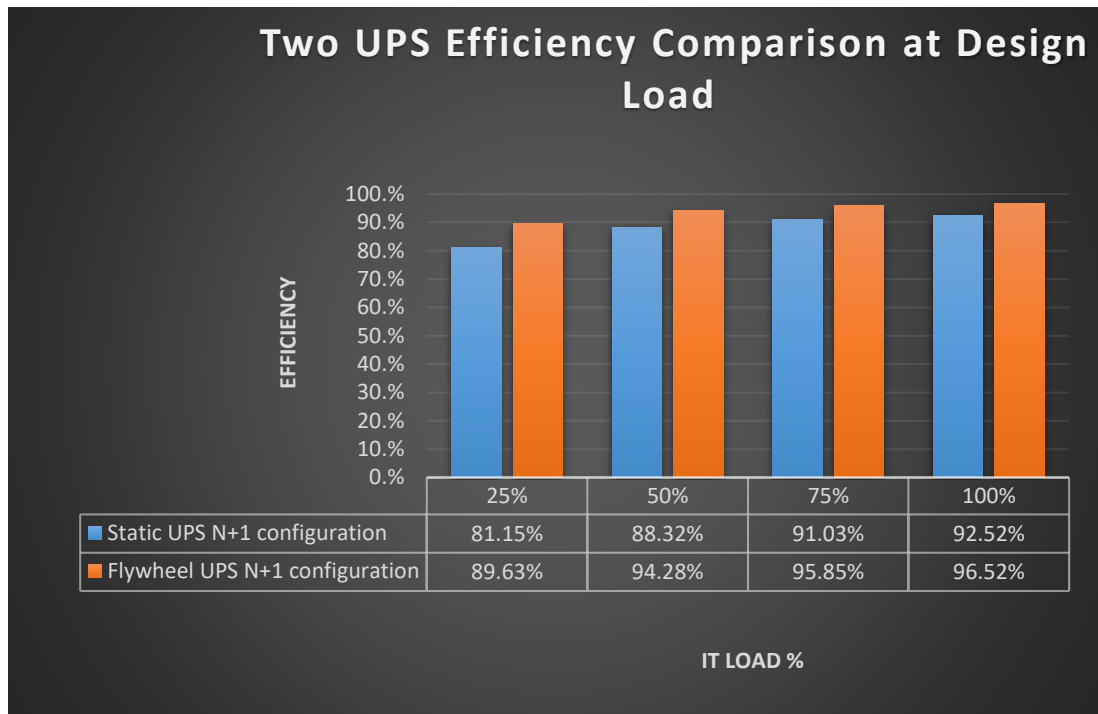

Figure 5.13: Two UPS technologies efficiency comparison N+1 configuration efficiency

5.4.2 Power Usage Effectiveness (PUE) comparison ‘2N’ redundancy configuration

The PUE is presented as a fraction above to help data centre operator to improve the efficiency of their facilities, if the given value is above 1, this means lower facility efficiency [93]. However, the value will always be greater than one but the closer it is to 1 the better the data centre is perceived in terms of energy efficiency. Also, the PUE enables comparison to be made with other similar facilities that are perhaps operating different mechanical and UPS systems

The data shown in Figure 5.14, below compares the PUE of a specific data centre designed to supply 1500 kW of IT load. The facility parameters remain constant for the purpose of the calculations, only adjusting the UPS details. The graph above illustrates how the facility operating flywheel technology achieves the lowest PUE, compared with the Static UPS across all levels of electrical loading. The optimum PUE achieved in N+1 configuration architecture was by the flywheel system operating at maximum load, achieving a PUE of 1.2.

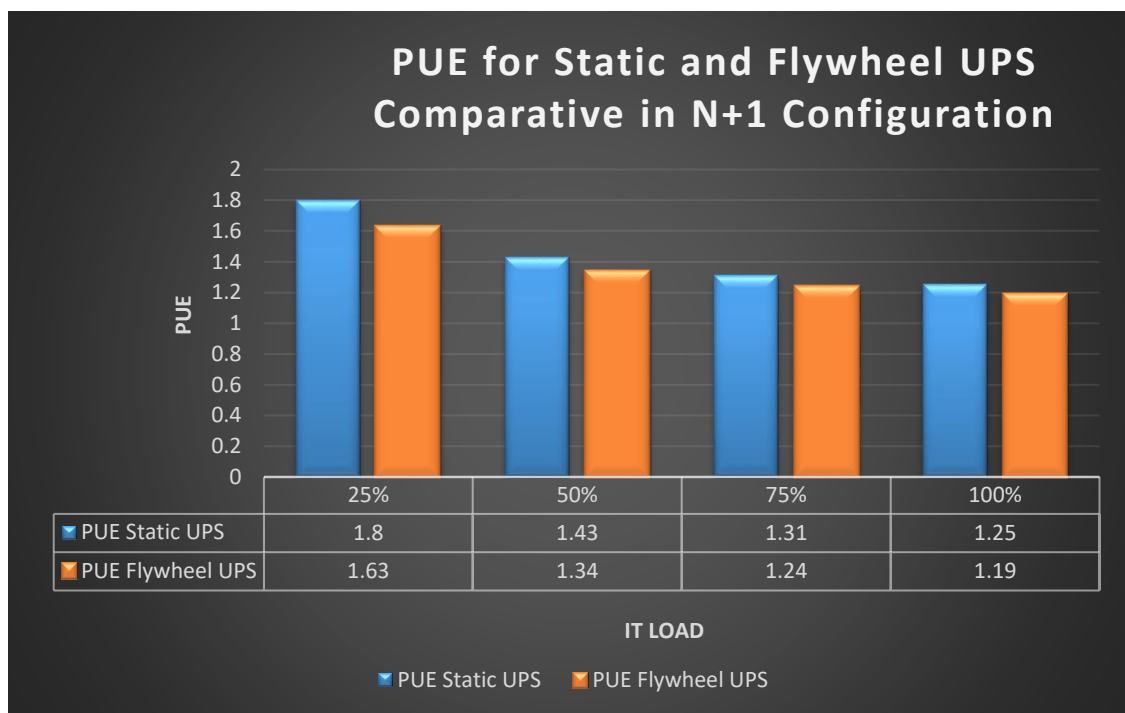

Figure 5.14: PUE for static and flywheel UPS comparative in N+1 configuration

5.4.3 Two UPS technology energy cost comparison based on ‘N+1’ redundancy configuration

The operational costs of the 1500 kW data centre designed using the two UPS technology types and all configured to N+1 redundancy configuration. These cost calculations are a direct function of the energy use analysis for every unit of electricity take in has a cost. The annual cost of operating the facility at half of its designed capacity.

The graph shown in Figure 5.15 reveals the predicted operational costs for the two UPS technology types of the 1500 kW data centre designed and configured to N+1 redundancy configuration. The annual energy costs for the facility have been calculated across a range of site loadings. For the flywheel, at 100% loading the UPS contributing £52.129, and reaching £46,239 at 25% loading. Whereas the double conversion static UPS is contributing £117.282 and reaching £101.372 at 25% loading.

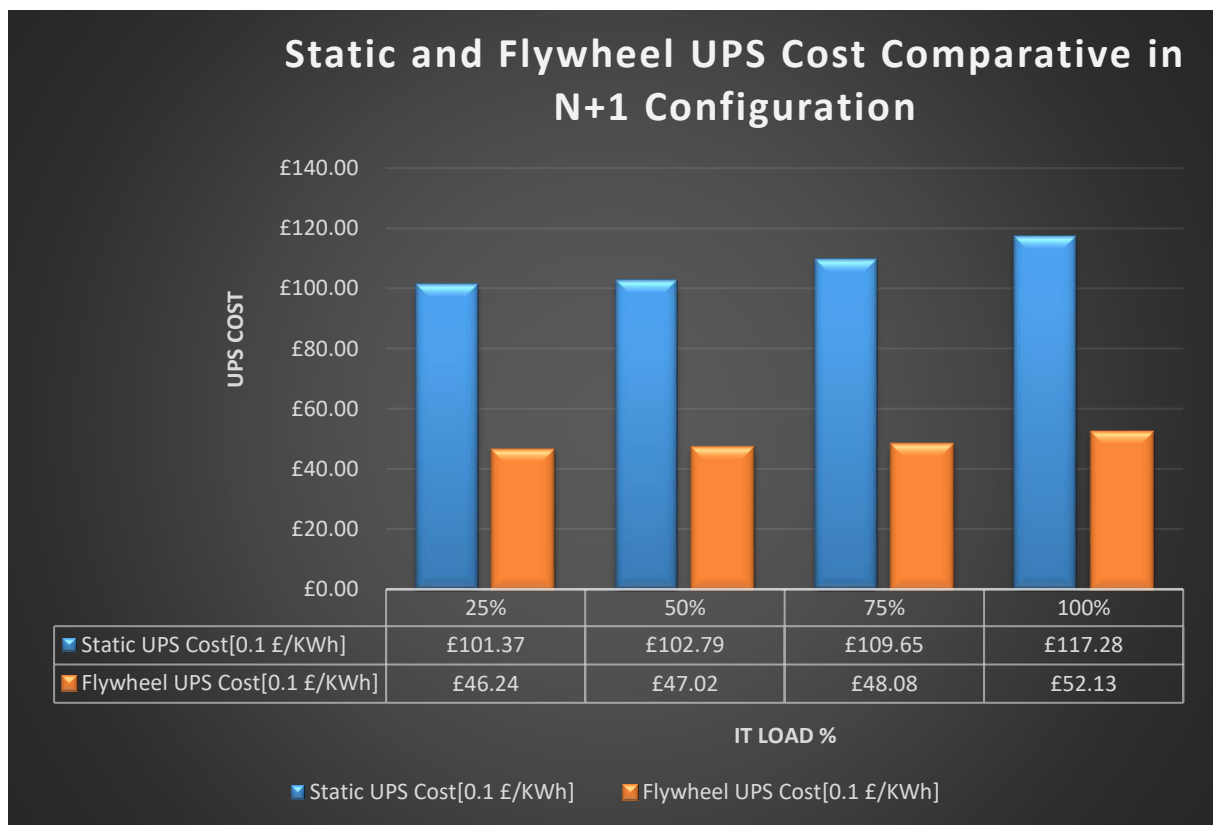

Figure 5.15: Static and flywheel UPS cost comparative in N+1 configuration

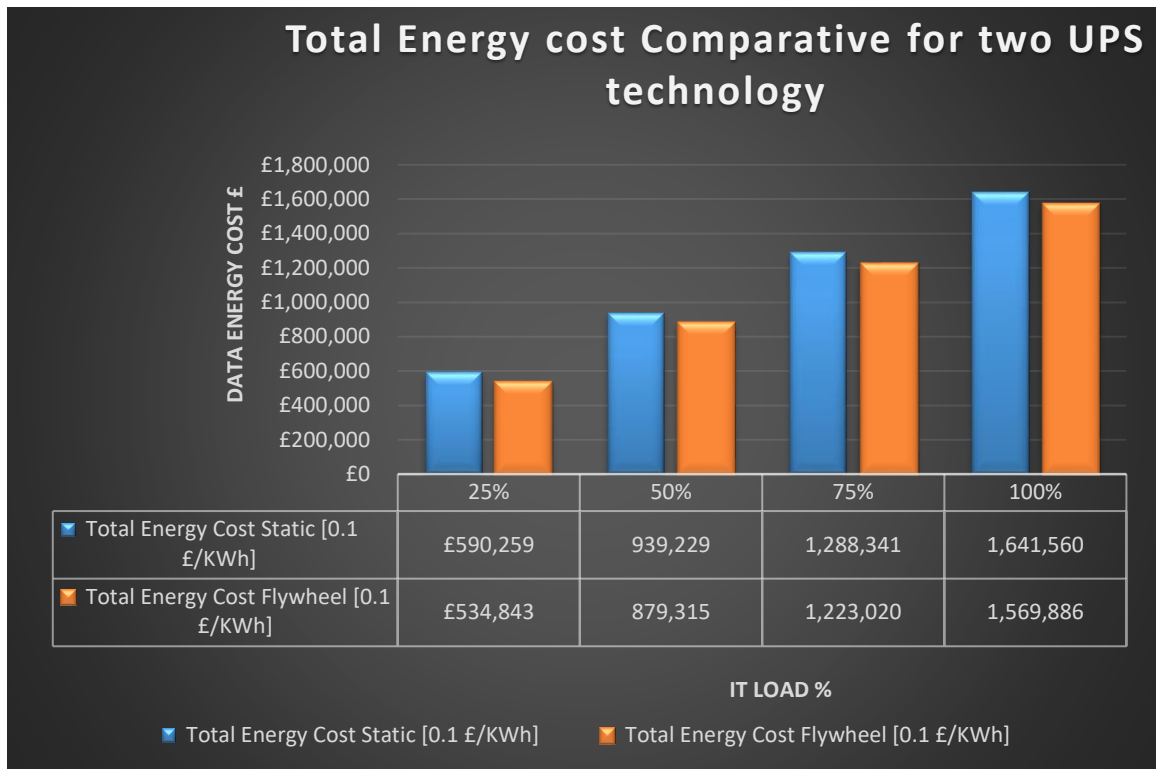

Figure 5.16: Total energy cost comparative in N+1 configuration for two UPS technology

The operational costs of the 1500 kW data centre designed using the two UPS technology types and all configured to N+1 redundancy configuration. These cost calculations are a direct function of the energy use analysis for every unit of electricity take in has a cost. The annual cost of operating the facility at half of its designed capacity.

The graphs in Figures 5.15 and 5.16, reveal the predicted operational costs for the two UPS technology types and the impact of the UPS on overall energy costs, of the 1500 kW data centre designed and configured to N+1. The annual energy costs for the facility have been calculated across a range of site loadings. For the flywheel, at 100% loading the UPS contributing £52.13, and reaching £46.24 at 25% loading. Whereas the double conversion static UPS is contributing £117.28 and reaching £101.37 at 25% loading.

5.5 Summary

Comparing both the flywheel UPS and double conversion static UPS in terms of efficiency, and cost, used in the analysis. The calculations in 'N+1' redundancy configuration UPS efficiency show that at 50% capacity the efficiency of the flywheel technology is 94.28%. Whereas the double conversion static UPS only achieves 88.32%, and the efficiency of flywheel technology at 100% capacity is 96.52%, whereas the double conversion static UPS only achieves 92.52% at 100% capacity load. Thus, the flywheel UPS is more efficient than the static type for the 'N+1' redundancy configuration. flywheel UPS is more economical than a double conversion static UPS. The main reasons for this are the low maintenance costs and the long service life of the flywheel compared to the double conversion UPS, which more than balances out the higher acquisition costs at the start of installation. Whereas a flywheel UPS, usually has the same service life as the UPS system, battery installations should be replaced several times during the service life of a UPS. This study reveals, that flywheel based UPS systems, provide better efficiency and cost dramatically, across the board than conventional double-conversion UPS with batteries, based mainly on the two-step process of converting utility power from AC to DC, and then from DC to AC. This higher efficiency meets the power quality and system reliability target.

Chapter 6: COMPARATIVE ANALYSIS BETWEEN ‘N+1’ CONFIGURATION AND ‘2N’ CONFIGURATION IN TERMS OF EFFECICNECY, PUE, AND COST.

6.1 Introduction

To evaluate the data centre, Uptime Institute made standard Tier Classification System and defined it as [I to IV]. The tire classifications were created to describe the data centre facilities reliably in terms of potential site infrastructure. The tiers [I to IV] are developing or happening gradually, each Tier incorporates the requirements of all the lower Tiers [16]. The most two classifications tires used in a medium and large data centre. Tier III and tier IV. Because both requires no shutdowns for equipment replacement and maintenance [17]. In this work the system is designed in accordance with the Uptime Institute Tier III requirements, as mentioned above, the Uptime Institute specify that all the IT equipment is dual corded or powered in that it can accept both an A and B supply from alternate sources [24].

The parallel UPS redundancy 2N and N+1 configuration system used in this work allow the UPS modules to operate in parallel as a backup for each other. The uninterruptible power supply continuous supply the power to the critical loads. During commercial electrical power problems and support the load while the power source shifts from utility to a standby generator. But in the case for any reason that the UPS is offline or taken out of service for maintenance, so the other UPS stands ready to take over the load from another UPS whenever necessary, without disrupting protected loads. A different data centre enterprise provides sufficient redundancy to deal with any unexpected power outages. But redundancy comes in different forms. For instance, data centre may offer ‘N+1’ and ‘2N’ redundancy systems. However, in this chapter briefly compare between the parallel UPS Redundancy 2N and N+1 Configuration system for two UPS technology used in this work.

6.2 Double conversion UPS system based on 2N and N+1 redundancy configuration comparison.

The system selected for the ‘2N’ redundancy configuration, is scalable in blocks of 275 kVA up to a maximum of 1100 kVA, the UPS requirement for the design adopted requires four UPS 1100 kVA modules. Two UPS are paralleled on “A” side and the other two UPS are paralleled on side “B”. Whereas the ‘N+1’ configuration the UPS requirements for the same design to be adopted here require 3 UPS. 1100 kVA modules paralleled together on both A and B strings.

6.2.1 Double conversion UPS system efficiency comparison based on 2N and N+1 redundancy configuration.

The 2N redundancy configuration 100% loading will only ever represent a 50% loading on the site UPS as there will always be a minimum of 50% redundancy [77]. The impact of this redundancy has on efficiency is shown in Table 6.1 with the UPS efficiency at 25% site load running at approximately 76.2%, i.e. 23.8% losses, and a maximum UPS double conversion type efficiency peaking at 90.88%. Whereas ‘N+1’ configuration, the system achieves 81.15% at 25% load and reaches 92.52% when the facility reaches maximum capacity.

Table 6.1: Static UPS efficiency comparison between 2N and N+1 redundancy configuration

IT Load %	100%	75%	50%	25%
Static UPS Efficiency in [2N Configuration]	90.88%	88.83%	85.06%	76.21%
Static UPS Efficiency in [N+1 Configuration]	92.52%	91.03%	88.32%	81.15%

The efficiency values recorded are based on IT loading across a complete spectrum from 0 to 100% load (see Figure 6.1).

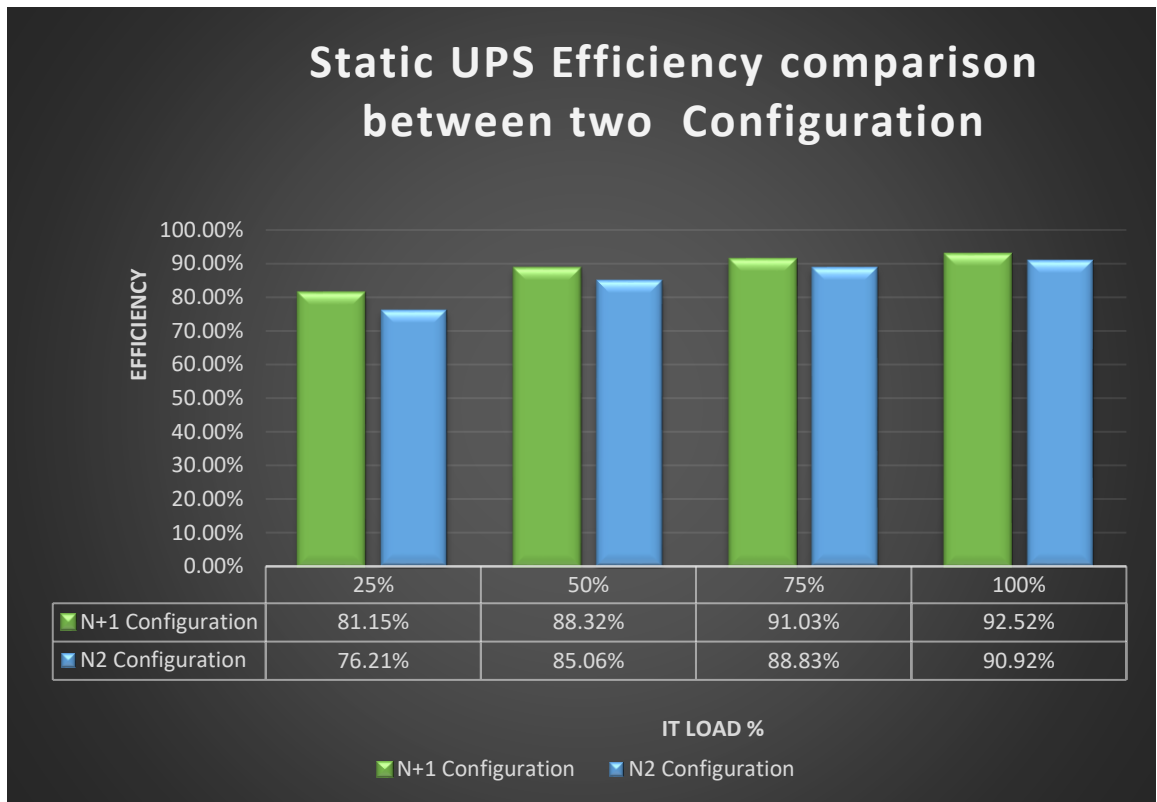

Figure 6.1: Static UPS efficiency comparison based on 2N and N+1 configuration

Figure 6.1, reveal that static UPS topologies based on N+1 configuration is more efficient and achieved 92.52% at 100% load, whereas at the same load in 2N configuration 90.92%. And that because of the additional losses experienced in the 2N topology result in a PUE of 1.91 for the same load. This is especially critical where the data centre will work at low load for a delayed period as the net effect will be expanded operational expenses.

6.2.2 Double conversion system applied in 2N and N+1 redundancy configuration comparison in terms of power usage effectiveness.

Power usage efficiency, it measures how effective your data centre is in using the input power. This ratio of power available to power used will yield a factor of greater than 1. The larger the number the less efficient your utilization is [92]. Table 6.2 illustrations the power usage effectiveness, of the 2N and N+1 redundancy configuration static UPS technology and the simulations undertaken for the data centre designed to provide 1500 kW of to support IT load.

Table 6.2: Static UPS power usage effectiveness comparison based on 2N and N+1 configuration

IT Load %	100%	75%	50%	25%
Static UPS PUE in [2N Configuration]	1.27	1.3	1.5	1.9
Static UPS PUE in [N+1 Configuration]	1.25	1.31	1.43	1.80

The table above represents the PUE for the data centre at various levels of IT load and different configuration, as the total facility power inclusive of all losses is divided by the power consumed by the data centre IT equipment. Clearly that the PUE metric in 2N Configuration obtains to 1.27 at the maximum load 100%. Whereas in N+1 redundancy configuration the PUE metric is 1.25. As mentioned above the value will always be greater than one but the closer it is to 1 the better the data centre is perceived in terms of energy efficiency.

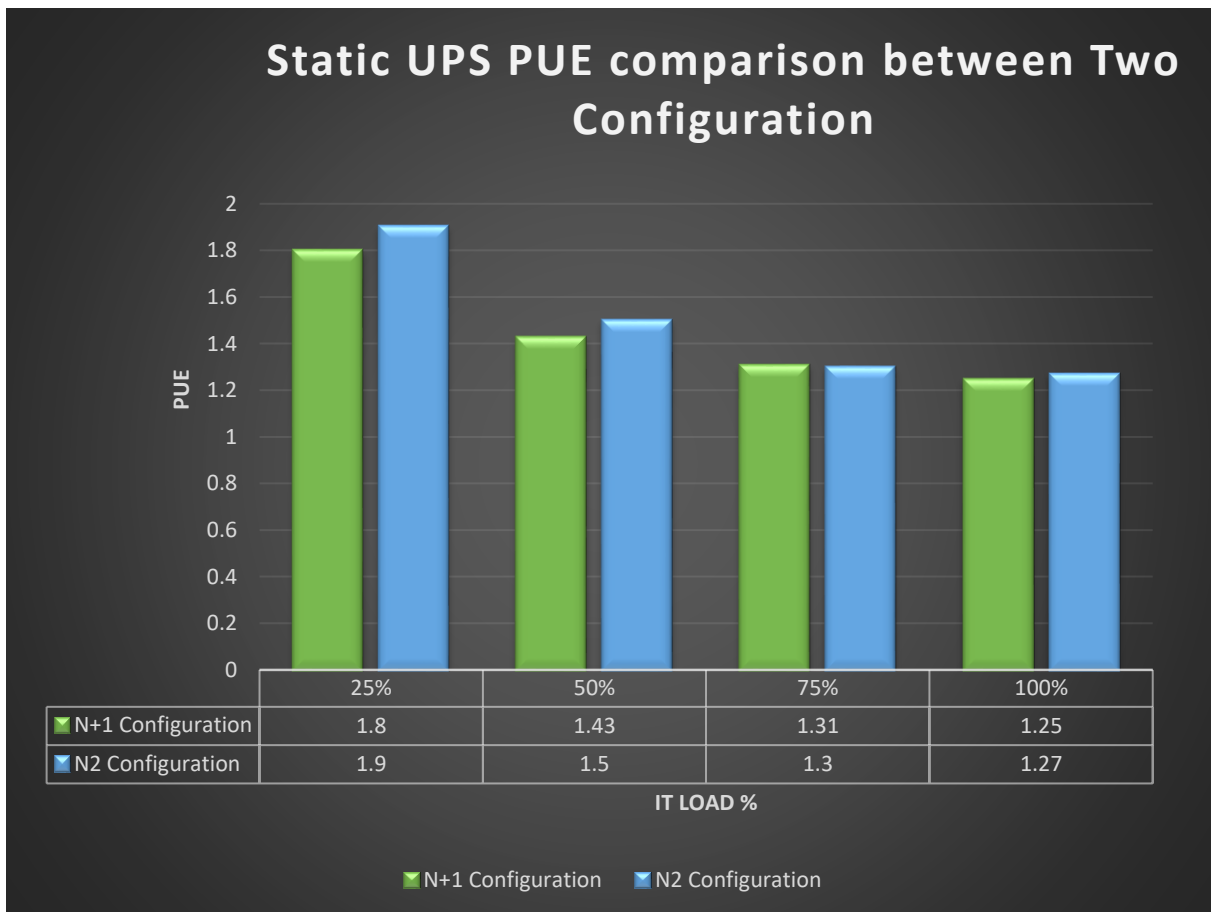

Figure 6.2: Static UPS PUE comparison based on 2N and N+1 configuration

Figure 6.2, reveal that the power usage effectiveness for static UPS topologies run in N+1 configuration is 1.25. Whereas in 2N configuration 1.27. As mentioned in the previous chapter, if the PUE is equal or closer to 1, this means a perfect efficient facility.

6.2.3 Data centre energy cost comparison based on double conversion UPS system applied in 2N and N+1 redundancy configuration.

For data centre managers and operators selecting the right UPS for deployment in terms of cost can be a difficult decision. Therefore, clarify the date centre energy cost and the impact of the UPS on overall energy costs, for two UPS technology applied in data centre for 2N and N+1 configuration. In this work, the cost calculation for the data centre energy is straight related to the absorbed power. At £0.10 per kWh. And the cost of the electricity calculated for one year of operation at 50% loading and recorded against site load ranging from 25% right up to 100%. Table 6.3 indicate the cost calculation for the date centre energy and UPS.

Table 6.3: Date centre energy cost comparison based on static UPS applied in 2N and N+1 configuration.

IT Load %	100%	75%	50%	25%
kWh 2N Configuration	16,708,102	13,197,684	9,739,031	6,264,588
Cost [0.1 £/kWh]	£1,670,710	£1,319,668	£973,803	£626,359
kWh N+1 Configuration	16,415,606	12,883,418	9,392,286	5,902,586
Cost [0.1 £/kWh]	£1,641,560	£1,288,341	£939,229	£590,259

The cost of the data centre energy would be £939,229 based on the N+1 configuration, at 50% loading, whereas at 2N configuration is £973,803. At the same load. (see Figure 6.3).

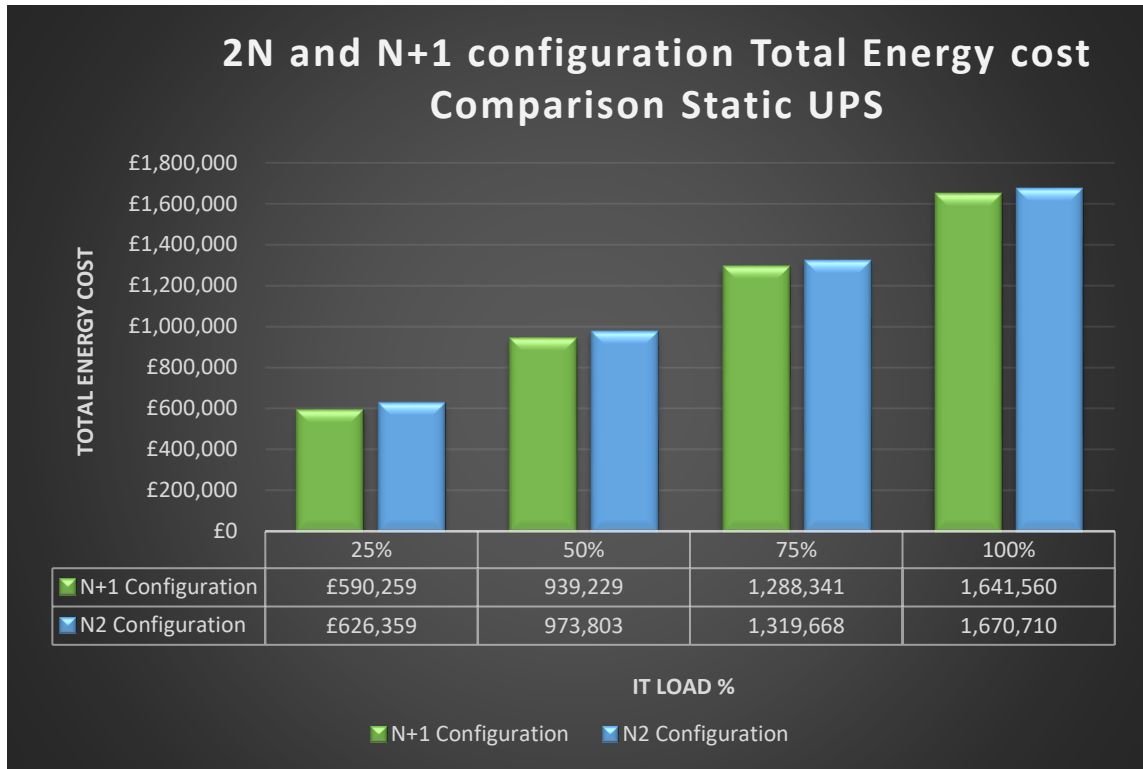

Figure 6.3: Date centre energy cost comparison based on 2N and N+1 configuration.

6.2.4 Double conversion UPS system cost comparison based on 2N and N+1 redundancy configuration.

Also, the cost calculation for the UPS are straight related to the absorbed power, at £0.10 per kWh. The cost of the electricity calculated for one year of operation at 50% loading, and recorded against site load ranging from 25% right up to 100%. (see Table 6.4).

Table 6.4: Static UPS cost comparison for 2N and N+1 configuration.

IT Load %	100%	75%	50%	25%
Static UPS kWh 2N Configuration	1.456.765	1.399.188	1.366.514	1.363.322
Static UPS 2N Configuration Cost [0.1 £/kWh]	£145.676	£139.919	£136.651	£136.322
Static UPS kWh N+1 Configuration	1.172.817	1.096.455	1.027.860	1.013.724
Static UPS N+1 Configuration Cost [0.1 £/kWh]	£117.282	£109.645	£102.786	£101.372

The cost of the UPS static type would be £102.786 based on the N+1 configuration at 50% loading, whereas at 2N configuration is £136.651 at the same load (see Figure 6.4).

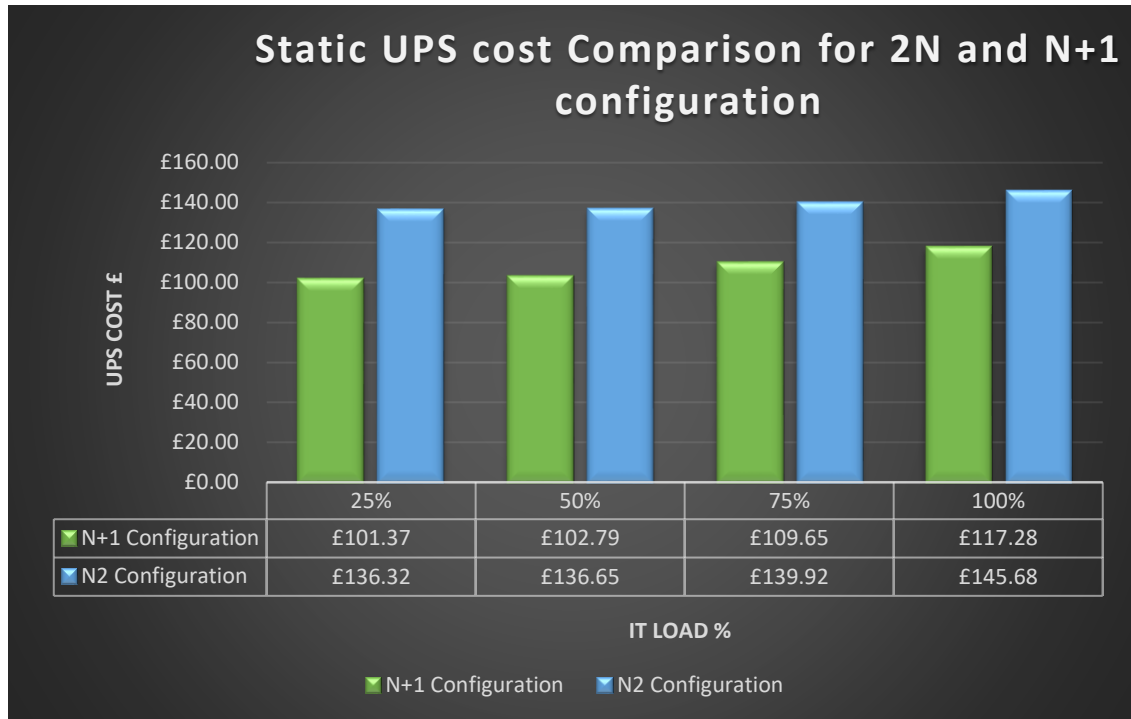

Figure 6.4: Static UPS cost comparison based on 2N and N+1 configuration

6.3 Flywheel UPS system comparison based on 2N and N+1 redundancy configuration.

The system that has been selected for this comparative study is a market leader in the flywheel technology that has been successfully deployed in data centre applications [67]. The flywheel UPS system examined is based on a design in which a 1000 kVA system is composed of four 250 kVA flywheels. The UPS requirements for the ‘2N’ redundancy configuration design require eight UPS 250kVA modules; four UPS are paralleled on “A” side and another four UPS paralleled on side “B”. Whereas the ‘N+1’ configuration the UPS requirements for the same design three 1000 kVA design is composed of a total of 12 UPS 250 kVA modules integrated to provide the required levels of redundancy (as shown in Figures 4.8 and 5.8).

6.3.1 Flywheel UPS system efficiency comparison based on 2N and N+1 redundancy configuration.

The results in Table 6.5 have been measured across the complete spectrum of loading on the site to enable comparison with the alternative technologies. The 2N redundancy configuration 100% loading will only ever represent a 50% loading on the site UPS as there will always be a minimum of 50% redundancy.

Table 6.5: Flywheel UPS efficiency comparison based on 2N and N+1 redundancy configuration

IT Load %	100%	75%	50%	25%
Flywheel UPS Efficiency in [2N Configuration]	95.79%	94.68%	92.40%	81.50%
Flywheel UPS Efficiency in [N+1 Configuration]	96.52%	95.85%	94.28%	89.63%

The impact of this redundancy has on the efficiency of the UPS at 50% site load running at approximately 92.40% and a maximum flywheel UPS type efficiency peaking 95.79% at full load. Whereas ‘N+1’ configuration, the system achieves 94.28% at 50% load and reaches 96.52% when the facility reaches maximum capacity.

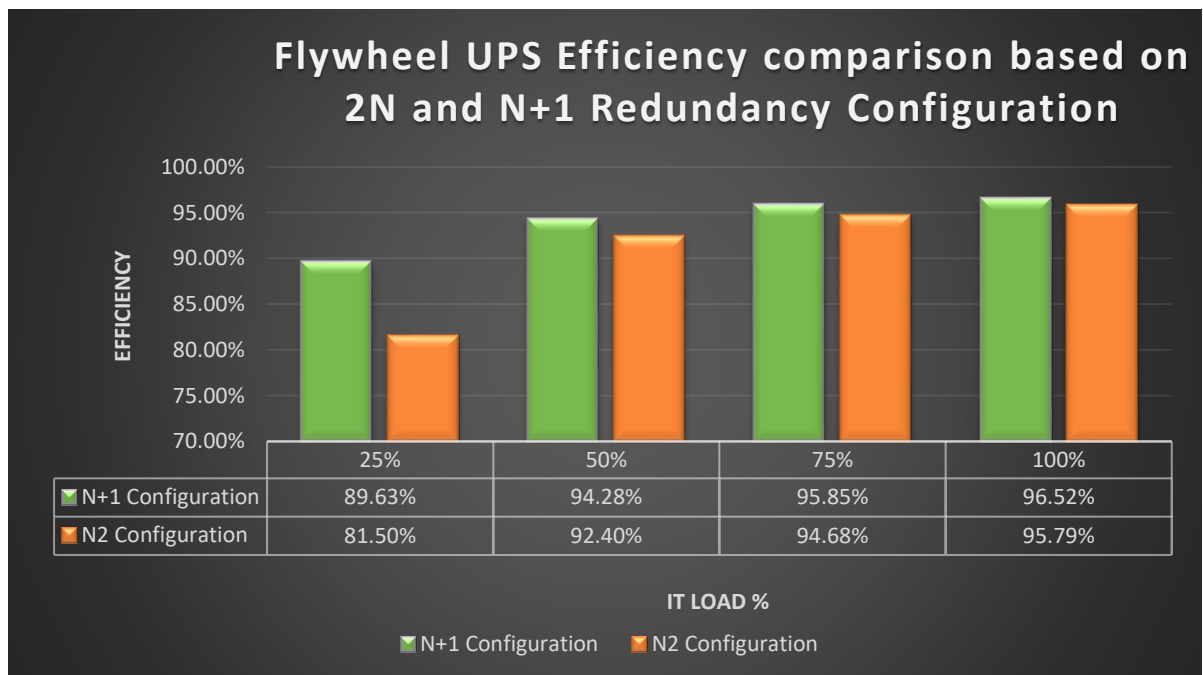

Figure 6.5: Flywheel UPS efficiency comparison based on 2N and N+1 configuration

This comparison is based only on the site design load, as Figure 6.5, reveal that flywheel UPS topologies run in N+1 configuration is more efficient The UPS achieves 96.52% at 100% load, whereas at the same load in 2N configuration achieved 95.79%. That because of the additional losses experienced in the 2N topology. This is especially critical where the data centre will work at low load for a delayed period as the net effect will be expanded operational expenses.

6.3.2 Flywheel UPS system applied in 2N and N+1 redundancy configuration comparison in terms of power usage effectiveness (PUE).

The PUE is presented as a fraction whereby the total facility power inclusive of all losses is divided by the power consumed by the Data Centre IT equipment [92]. Table 6.6, illustrate the PUE, of the 2N and N+1 redundancy configuration flywheel UPS technology and the calculations undertaken for the data centre designed to provide 1500 kW of IT load.

Table 6.6: Flywheel UPS power usage effectiveness comparison based on 2N and N+1 configuration

IT Load %	100%	75%	50%	25%
Flywheel UPS PUE in [2N Configuration]	1.23	1.27	1.36	1.8
Flywheel UPS PUE in [N+1 Configuration]	1.19	1.24	1.34	1.63

The table above represents the PUE for the data centre at various levels of IT load and different configuration, as the total facility power inclusive of all losses is divided by the power consumed by the data centre IT equipment.

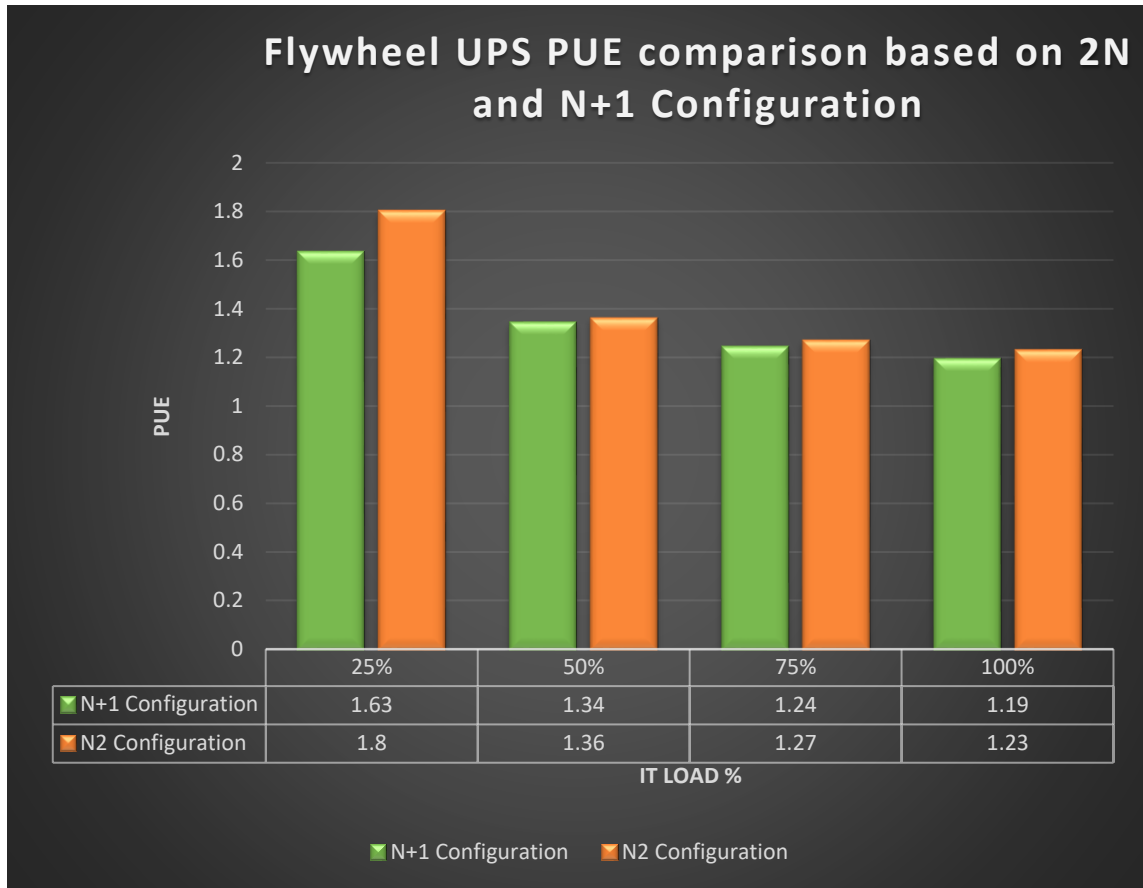

Figure 6.6: Flywheel UPS PUE comparison based on 2N and N+1 configuration

Clearly, Figure 6.6, reveals that the PUE of the flywheel UPS topologies metric in 2N configuration obtain to 1.23 at the maximum load 100%. Whereas in N+1 redundancy configuration the PUE metric is 1.19. As mentioned above the value will always be greater than one but the closer it is to 1 the better the Data Centre is perceived in terms of energy efficiency.

6.3.3 Data centre energy cost comparison based on flywheel UPS system applied in 2N and N+1 redundancy configuration.

In this work, the cost calculation for the data centre energy is straight related to the absorbed power. At £0.10 per kWh. And the cost of the electricity calculated for one year of operation at 50% loading and recorded against site load ranging from 25% right up to 100%. The cost calculation for the date centre energy and UPS (see Table 6.7).

Table 6.7: Date centre energy cost comparison based on flywheel applied in 2N and N+1 configuration.

IT Load %	100%	75%	50%	25%
kWh 2N Configuration	15,816,064	12,377,423	8,965,607	5,850,349
Cost [0.1 £/kWh]	£1,581,607	£1,237,743	£896,562	£585,036
kWh N+1 Configuration	15,648,855	12,230,205	8,793,146	5,348,434
Cost [0.1 £/kWh]	£1,569,886	£1,223,020	£879,315	£534,843

The cost of the data centre energy would be £879.315 based on the N+1 configuration, at 50% loading, whereas at 2N configuration is £896.562, at the same load. (see Figure 6.7).

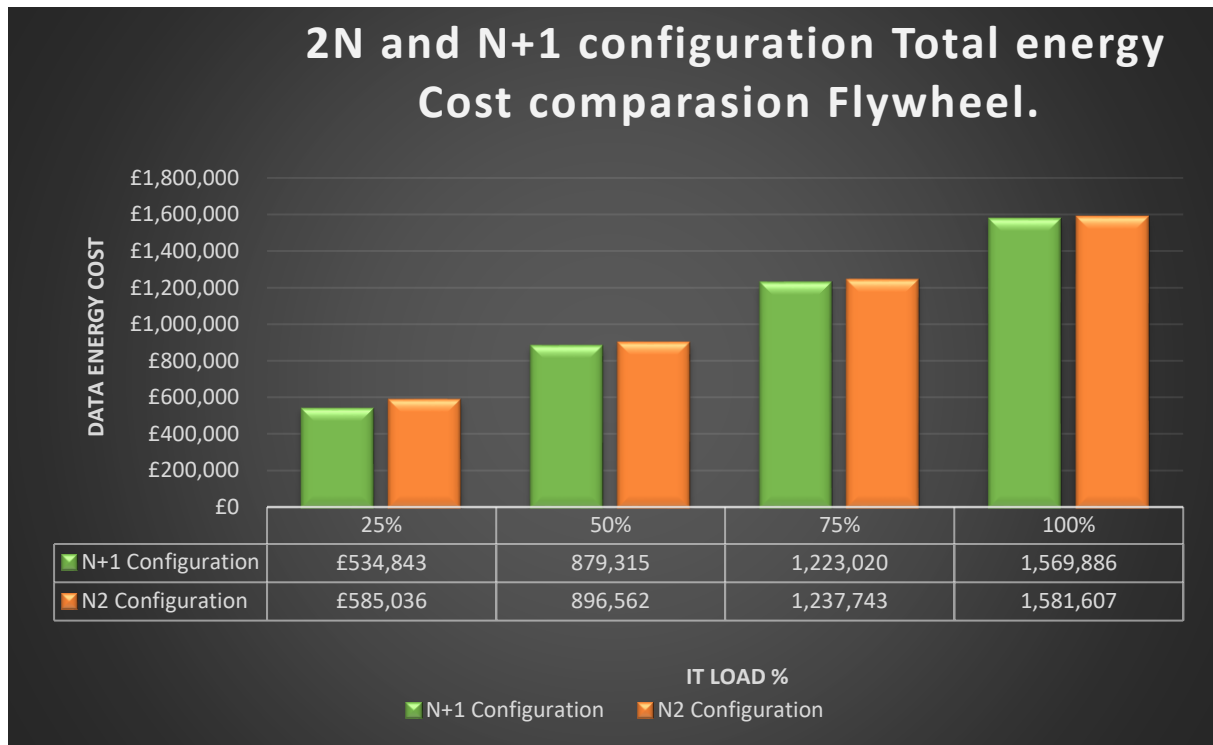

Figure 6.7: Date centre energy cost comparison Based on flywheel Applied in 2N and N+1 configuration.

6.3.4 Double conversion UPS system cost comparison based on 2N and N+1 redundancy configuration.

Also the cost calculation for the UPS flywheel type are straight related to the absorbed power. At £0.10 per kWh, the cost of the electricity calculated for one year of operation at 50% loading, and recorded against site load ranging from 25% right up to 100%. As shown in Table 6.8.

Table 6.8: Flywheel UPS cost comparison based on 2N and N+1 configuration.

IT Load %	100%	75%	50%	25%
Flywheel UPS kWh 2N Configuration	635,451	623,985	637,490	985,654
Flywheel UPS 2N Configuration Cost [0.1 £/kWh]	£63,545	£62,398	£63,749	£98,565
Flywheel UPS kWh N+1 Configuration	521,239	480,821	470,220	462,386
Flywheel UPS N+1 Configuration Cost [0.1 £/kWh]	£52,129	£48,082	£47,022	£46,239

The cost of the uninterruptible power supply (UPS) flywheel type, would be £47.022 based on the N+1 configuration at 50% loading, whereas at 2N configuration reordered as £63.749, at the same load. (see Figure 6.8).

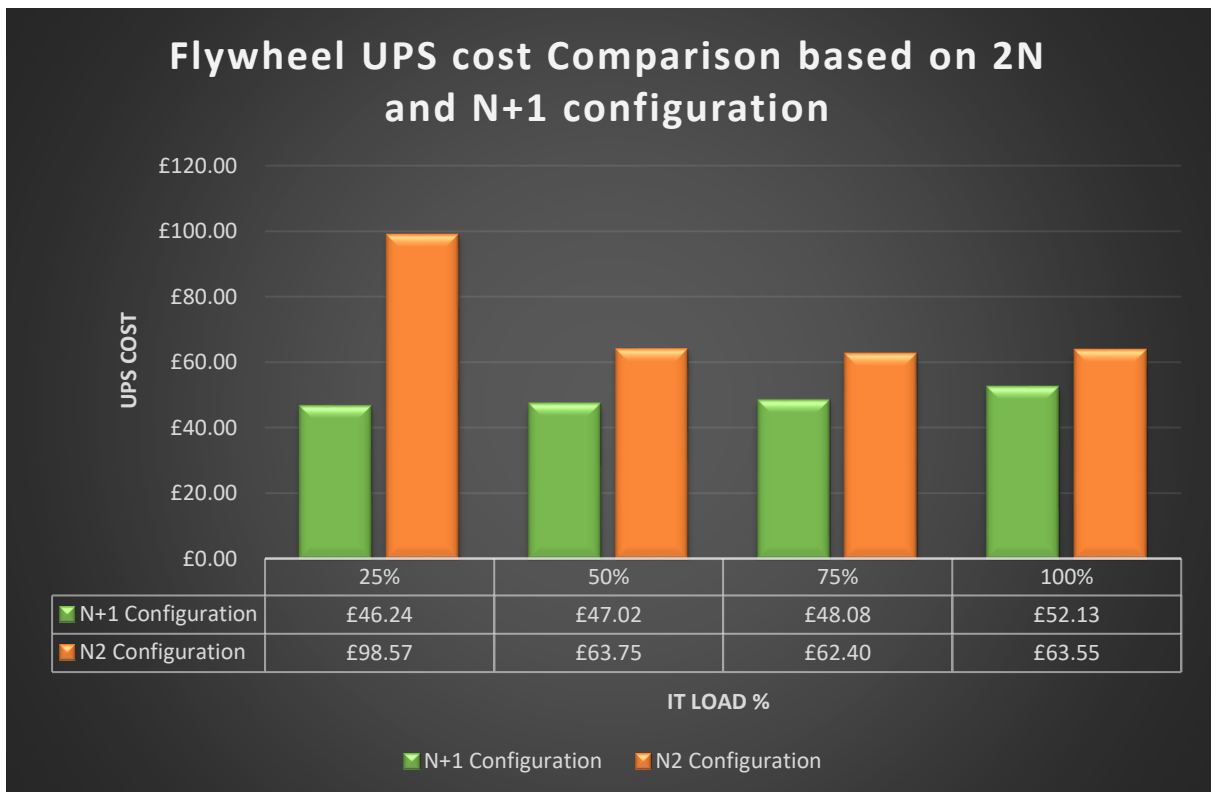

Figure 6.8: Flywheel UPS cost comparison based on 2N and N+1 configuration

6.4 Summary

Chapter six, presented comparison tables and graphs for all two UPS technologies, static UPS system double conversion type and flywheel UPS system. based on 2N' and N+1 redundancy configuration, in terms of efficiency, power usage effectiveness (PUE), energy and UPS cost. Based on their operating parameters, also considering the impact each system would have on the overall operation of the data centre. And provided a barometer by which each of the UPS technologies could be measured and used as part of the selection criterion.

Firstly, in this work considering the UPS double conversion type, running in 2N and N+1. redundancy configuration, the study reveal in 2N configuration, the efficiency at 25% site load running at approximately 76.2%, i.e. 23.8% losses, and a maximum UPS efficiency peaking at 90.88%. Whereas 'N+1' configuration, the system achieves 81.15% at 25% load and reaches 92.52% when the facility reaches maximum capacity. Also, clearly shows that the PUE metric in 2N Configuration obtains to 1.27 at the maximum load 100%. Whereas in N+1 redundancy configuration the PUE metric is 1.25.

Furthermore, the cost of the UPS static type, would be £102.786 based on the N+1 configuration at 50% loading, whereas at 2N configuration is £136.651, at the same load.

Also in this work, considering the flywheel type deployed in two configurations 2N and N+1. reveal that when the UPS run in N+1 configuration is more efficient. The UPS achieves 96.52% at 100% load, whereas at the same load in 2N configuration achieved 95.79%. Also, that the power usage effectiveness (PUE) flywheel UPS topologies metric in 2N Configuration obtain to 1.23 at the maximum load 100%. Whereas in N+1 redundancy configuration the PUE metric is 1.19.

Furthermore, the cost of the UPS flywheel type, would be £47.022 based on the N+1 configuration at 50% loading, whereas at 2N configuration reordered as £63.749, at the same load.

Chapter 7: CONCLUSIONS AND FUTURE RESEARCH

This chapter presents the main conclusions of the thesis and identifies areas for future work.

7.1 Discussion and Conclusion

This dissertation is designed to provide data centre managers and operators, with a clearer understanding of key factors and considerations involved in selecting the right UPS system, and how can future UPS system topology and technology improve the data centre in terms of efficiency and cost. In order to analyse the different UPS technologies and their operating efficiencies have on the overall PUE of the data centre. An electrical model for a medium size data centre is designed to provide 1500 kW to support the IT load. The data centre selected is assumed to be of the modular type operating on free air cooling which has been calculated to be available for 99% of the year in London based on ASHRAE weather data. The designed IT load is 1500 kW, this in turn is the maximum power density of the facility. Computer based software programs such as the 'ROMONET' are used to offer a predictive modelling tool for the data centre in order to evaluate how it would operate under different conditions. For the purpose of this research project, devoted Excel Calculation spread sheets have been created to allow the user to translate and include the manufacturer data properly so that a reasonable investigation of the distinctive frameworks can be attempted. The system is designed in accordance with the Uptime Institute Tier III requirements, the Uptime Institute specify that all the IT equipment is dual corded or powered in that it can accept both A and B supply from alternate sources [31,32]. The electrical infrastructure topology to be adopted is configured to '2N' and 'N+1' redundancy configuration for each of the two UPS systems technologies (Double conversion static UPS system and flywheel), where 'N' stands for the number of UPS modules that are required to supply power to data centre. The methodology used in this are listed below.

- **'ROMONET' Computer based software programs**
- **Tier III Facility**
- **Two UPS technology comparison in 2N Configuration system**
- **Two UPS technology comparison in N+1 Configuration system**
- **Power Usage Effectiveness (PUE)**
- **Data Centre Infrastructure Efficiency (DCIE)**
- **Excel Calculation spread sheets have been created**

The following conclusions have been drawn from this research based on data centre model calculations reported,

7.1.1 Double conversion static UPS and flywheel UPS system in 2N configuration in a medium size data centre

Historically, data centre managers and operators have had to balance between efficiency and availability in the data centre power system. Double conversion static UPS system provided the highest availability but could not deliver the same efficiency as a flywheel UPS system type. In this model when comparing both the flywheel UPS and double conversion static UPS in terms of efficiency, PUE and cost, used in the analysis. The calculations in '2N' redundancy configuration shows that at 50% capacity the efficiency of flywheel technology is 92.4%, by contrast, the double conversion static UPS only achieves 85.1%. Also, the efficiency of flywheel technology at 100% capacity is 95.7%, whereas, the double conversion static UPS only achieves 90.8% at 100% capacity load. Thus, the flywheel UPS is more efficient than the static type for the '2N' redundancy configuration. And the cost for the flywheel at 100% loading the UPS contributing £63,545 and reaching £98,566 at 25% loading. Whereas the double conversion static UPS is contributing £145,676 and reaching £136,322 at 25% loading. This study reveals, that flywheel based UPS systems, provide dramatically better efficiency across the board than conventional double-conversion UPS with batteries, based mainly on the two-step process of converting utility power from AC to DC, and then from DC to AC. This higher efficiency meets the power quality target.

Furthermore, the operational and maintenance cost comparative for two UPS technology, in this study where the data centre has been designed. Will not operate at 100% load from day one. And the 2N redundancy configuration 100% loading will only ever represent a 50% loading on the site UPS as there will always be a minimum of 50% redundancy [76]. A lifecycle period of five years has been captured from initial capital investment, incorporating all maintenance, together with the operational costs. For the first year, the facility has a capacity of 25% and reaching its full capacity of 1500kW by year five. Furthermore, the cost of Generator Integrated in to the double conversion static UPS and the flywheel UPS to allow fair comparison. The maintenance cost requirements are £1,925,000 and the operational cost is £7,728,740 for the double conversion static UPS. Whereas, the maintenance cost requirements are £1,815,000 and the operational cost is £7,522,125 for the flywheel UPS technology.

As a result, shown in this work, flywheel UPS technology systems have been proven in a model of a medium size data centre in '2N' redundancy configuration, to have lower operational and maintenance cost, and significantly higher energy efficiencies. This higher efficiency can result in hundreds of thousands of pounds, in annual cost savings for typical data centres, compared to double-conversion UPS systems. Clearly, based on a 1100 kVA system, 2N configuration system option, around which the data centre in this study has been designed. The Logical choice for data centre managers and operators would be a flywheel UPS technology.

7.1.2 Double conversion static UPS and flywheel UPS system in N+1 configuration in a medium size data centre

Comparing both the flywheel UPS and double conversion static UPS in terms of efficiency, PUE and cost, used in the analysis. The calculations in 'N+1' redundancy configuration UPS efficiency shows, that at 50% capacity the efficiency of flywheel technology is 94.28%, whereas the double conversion static UPS only achieves 88.32%, and the efficiency of flywheel technology at 100% capacity is 96.52%, whereas the double conversion static UPS only achieves 92.52% at 100% capacity load. Thus, the flywheel UPS is more efficient than the static type for the 'N+1' redundancy configuration, while the cost for the flywheel at 100% loading the UPS contributing £52.129, and reaching £46,239 at 25% loading. Whereas the double conversion static UPS is contributing £117.282 and reaching £101.372 at 25% loading. This study reveals, that flywheel based UPS systems, provide dramatically better efficiency and cost, across the board than conventional double-conversion UPS with batteries, based mainly on the two-step process of converting utility power from AC to DC, and then from DC to AC. This higher efficiency meets the power quality and system reliability target. Thus, in this work reveal that, flywheel UPS technology systems have been proven in a model of a medium size data centre in an N+1 redundancy configuration, to have significantly higher energy efficiencies. This higher efficiency can result in hundreds of thousands of pounds, in annual cost savings for typical data centres, compared to double-conversion UPS systems,

Clearly, based on a 1100 kVA system, N+1 configuration system option, around which the data centre in this study has been designed. The Logical choice for data centre managers and operators would be a flywheel UPS technology.

7.1.3 An N+1 and 2N redundancy configuration efficiency comparative

The need for increased availability and increasing capacity requirements have forced data centre managers and operators to focus their attention on infrastructure design that allows

greater flexibility, higher availability and the lowest total cost. In UPS systems configuration are being combined with flexible power distribution configurations “N”. As mentioned in chapter two, that the letter "N" when designing UPS configurations can simply be defined as the number of UPS modules that are required to supply power to IT load. In other words, the minimum backup protection required to feed the critical load [6].

The N+1 configuration system option, where N represents the number of UPS modules required to deliver the necessary amount of power for data centre operations. And the 1 refers to one extra UPS module. The N+1 configuration is not a fully redundant system. Because the system is run on two separate feeds, and system failures can still happen. In contrast, 2N redundancy configuration system means the data centre has double the amount of equipment needed. The load of the data centre is shared between two UPS systems or more on independent paths so that if one fails, the other will still supply the data centre critical load. This configuration represents a fully redundant system and a more reliable operation. Any power outages will have no adverse effect on data centre availability and no single point of failure to disrupt operations. This system redundant configuration is the most reliable and most expensive design in the UPS industry. Each of the system configurations used in this research, has its own advantages and disadvantages. And both configurations can improve system availability and reliability and simplifies maintenance of individual UPS modules.

In this study, comparing the two UPSs technology based on N+1 and 2N configuration system in terms of efficiency. Reveal that static UPS topologies run in in N+1 configuration is more efficient and achieved 92.52% at 100% load, whereas at the same load in 2N configuration 90.92%. Also, reveal that flywheel UPS topologies run in N+1 configuration is more efficient The UPS achieves 96.52% at 100% load, whereas at the same load in 2N configuration achieved 95.79%. The 2N redundancy configuration is more expensive and required for mission critical situations. So, if the cost were a factor, then data centre managers should select an enterprise data centre with N+1 configuration. If not, then of course should select an enterprise data centre with 2N redundancy configuration as no single point of failure to disrupt operations.

7.2 Recommendations and Future Work

In this thesis, the result from a medium size data centre has been designed at [RED Engineering Design Company Oxford, UK]. To provide 1500 kW of IT load, and the system designed in accordance with the Uptime Institute Tiers III level requirements. But due to the time limit and the long process to obtain a permission to get in the site. So, for that reasons

identified a number of areas for future research. The future work could investigate the suggestions including expanding some parts of this work, such as:

7.2.1 Use the Tier IV level instead of Tiers III.

As data centre managers have the responsibility to determine what Tier level is appropriate or require for their site. So, the owners must have a comprehensive image about both Tiers [III & IV]. Other research may be able to expand this particular work in tier IV. In this type tier IV, the data centre has redundant capacity components and multiple paths, simultaneously serving the site's computer equipment. All IT equipment is dual powered and fault-tolerant site infrastructure is also required for electrical power storage and distribution facilities [16, 17]. The distribution path and complementary system must be separated and isolated, to prevent any single event from the affecting both systems, the failure or maintenance of any two single units, modules or paths will not disrupt operations [16]. This tier IV level configuration are more expensive than tier III. So, if the cost were not a factor then some data centre owners prefer this tier level.

7.2.2 Increase the lifecycle period ten years instead of five years

A lifecycle period of five years is envisaged from the initial capital investment, incorporating all maintenance, together with the operational costs which have been detailed in this research. So, increasing the A lifecycle period to ten years help get more efficient result for long lifecycle period, includes the capital investment costs, maintenance requirements and operational cost. In addition, the cost of a generator integrated into the system.

7.2.3 Large size data centre with 6000 kW of IT load instead of medium size with 1500 kW

As data centre managers have the responsibility to determine what Tier level is appropriate or require for their site. Also, they have a responsibility to determine what is the size require for their site. So, to complete all key factors about how the UPS improve energy efficiency. Other research may be able to expand this particular work in a large data centre, by comparing the most popular UPSs types deployed in data centre. Flywheel UPS and double conversion static UPS technology in terms of efficiency, PUE and cost, supporting 6000kW of IT load, in a lifecycle period of ten years instead of five years. Of course, the result will help data centre managers and operators, with a clearer understanding of all key factors and considerations involved in selecting the right UPS system for their site.

REFERENCES

- [1] P. Bentley and D. Bond, "The UPS Handbook," 3rd edition. Berkshire: Uninterruptible Power Supplies. Ltd. 2007.
- [2] R&M, "Data Centre Handbook," V5.0 © 02 Reichle & De-Massari AG R&M. 2014.
- [3] P. Ranganathan, "Data centres and warehouse computing," *ECE282 Lecture 14, Stanford Electrical Engineering*, April. 2011.
- [4] M. Mills. "The cloud begins with coal," *Technical report, Digital Power Group*, 2013.
- [5] H. Chen, A. Coskun, and M. Caramanis. "Real-time power control of data centres for providing regulation service," In *Decision and Control (CDC), 2013 IEEE 52nd Annual Conference on*, 2013.
- [6] D. Aikema, R. Simmonds, and H. Zareipour. "Data centres in the ancillary services market," In *International Green Computing Conference (IGCC)*, pages 1–10. IEEE, 2012.
- [7] J. Koomey, "Worldwide electricity used in data centres," *Environmental Research Letters*, No. (3)- 034008, 2008.
- [8] Natural Resources Defence Council. "America's Data Centres Consuming and Wasting Growing Amounts of Energy," [Online]. Available: <http://www.nrdc.org/energy/data-centre-efficiencyassessment.asp> . February 2015.
- [9] M. Vargas, "10 Facts to Know About Data Centres" EERE [Online]. Available: <http://energy.gov/eere/articles/10-facts-know-aboutdata-centres> . November.2015.
- [10] H. Chen, M.C. Caramanis, and A.K. Coskun, "The data centre as a grid load stabilizer," In *Design Automation Conference (ASP-DAC), 2014 19th Asia and South Pacific*, pages 105–112, 2014.
- [11] G. Lawton, "Powering Down the Computing Infrastructure," in *Computer, the IEEE Computer Society*. p. 16-19. 2007.
- [12] W. Stanke, W. Sölter, "Causes of Data Loss in the IT field," *Power Quality Journal* pp. 36-37 February, 2000.
- [13] J. Koomey, "Growth in Data Centre Electricity Use 2005 to 2010," *Burlingame, CA, USA: Analytics Press*, 2011. [Online]. Available: <http://www.analyticspress.com/datacentres.html>

- [14] K.W. Roth, F.G. J. Klein man, "Energy Consumption by Office and Telecommunications Equipment in Commercial Buildings," *Report for Office of Building Equipment*, Massachusetts. 2002.
- [15] Y. Joshi and P. Kumar, "Introduction to data centre energy flow and thermal management," in *Energy Efficient Thermal Management of Data Centres*, Y. Joshi and P. Kumar, Eds. New York, NY, USA: Springer-Verlag, pp. 1–38. 2012.
- [16] A. Beloglazov and R. Buyya, "Energy efficient resource management in virtualized cloud data centres," in *Proc. 10th IEEE/ACM Int. CCGrid*, pp. 826–831. May 2010.
- [17] I. Bitterlin, "Exploring the concept of comparative PUE," London, ARK Continuity. 2009.
- [18] J. Choa, T. Limb, and B. Kimb, "Viability of data centre cooling systems for energy efficiency in temperate or subtropical regions," *Case study*". *Energy and Buildings* vol.55, pp.189– 197, 2012.
- [19] M. Vitali and B. Pernici, "A survey on energy efficiency in information systems," *Int. J. Cooperative Inf. Syst.*, vol. 23, no. 3, 2014.
- [20] K. W. Roth, F. Goldstein, and J. Kleinman, "Energy Consumption by Office and Telecommunications Equipment in Commercial Buildings Volume I: Energy Consumption Baseline," *Tech. Rep. Vol I, National Technical Information Service (NTIS)*, US Department of Commerce, Jan. 2002.
- [21] R. Buyya, A. Beloglazov, and J. Abawajy, "Energy-efficient management of data centre resources for cloud computing A vision, architectural elements, and open challenges," *CORR*, vol. abs/1006.0308, 2010.
- [22] M. Poess and R. O. Nambiar, "Energy cost, the key challenge of today's data centres: A power consumption analysis of TPC-C results," *Proc. VLDB Endowment*, vol. 1, no. 2, pp. 1229–1240, Aug. 2008.
- [23] Lawrence Berkeley National Laboratory, "Energy efficient data centres," *Consultant Report*, P500-04-004, Dec. 2003.
- [24] E. Masanet, R. Brown, A. Shehabi, J. Koomey, and B. Nordman, "Estimating the energy use and efficiency potential of us data centres," *Proceedings of the IEEE*, vol. 99, no. 8, pp. 1440–1453, 2011.
- [25] F. T. Chong, M. Heck, P. Ranganathan, A. Saleh, and H. Wassel, "Data centre energy efficiency: Improving energy efficiency in data centres beyond technology scaling," *IEEE Design & Test*, vol. 31, no. 1, pp. 93–104, 2014.

- [26] R. H. Katz, "Tech Titans Building Boom," *IEEE Spectrum*, vol. 46, pp. 40–54, Feb. 2009.
- [27] Y. Zhang, P. Chowdhury, M. Tornatore, and B. Mukherjee, "Energy Efficiency in Telecom Optical Networks," *IEEE Commun. Surveys & Tutorials*, vol. 12, no. 4, 2010.
- [28] Y. Gao, H. Guan, Z. Qi, B. Wang, and L. Liu, "Quality of service aware power management for virtualized data centres," *J. Syst. Architect.*, vol. 59, no. 4/5, pp. 245–259, Apr. 2013.
- [29] D. Abts, M. Marty, P. Wells, P. Klausler, and H. Liu. "Energy proportional Data Centre networks," *In International Symposium on Computer Architecture (ISCA)*, 2010.
- [30] TIA 942, "Telecommunications Infrastructure Standard for Data Centres, Telecommunications Industry Association," (TIA), 2014.
- [31] TS102120-0812, "Data Centre Site Infrastructure Tier Standard: Topology," *Uptime Institute, LLC*, 2012.
- [32] TS106130-0413, "Data Centre Site Infrastructure Tier Standard: *Operational Sustainability*," *Uptime Institute, LLC*, 2013.
- [33] C. Kachris, "Optical interconnection networks in data centres: recent trends and future challenges," *IEEE Communications Magazine*, vol.14, pp. 39-45, Sep. 2013.
- [34] D. Cole, "Data Centre Knowledge Guide to Data Centre Infrastructure Management," (DCIM), *Data Centre Knowledge*, May. 2012.
- [35] Ashrae, "Datacom Equipment Power Trends and Cooling Application," 2nd Edition, 2012.
- [36] P. Mahadevan, "On energy efficiency for enterprise and data centre networks," *IEEE Communications Magazine*, vol.49, pp. 94-100, Aug. 2011.
- [37] Decathlon, "Data Centre Infrastructure Management: Decathlon System Guide," ABB. Pte. Ltd., January, 2015.
- [38] W. P. Turner, J. H. Seader, and V. E. Renaud, "Data Centre Site Infrastructure Tier Standard: Topology," *Uptime Institute, LLC*, 2012.
- [39] R. Pries et al, "Power consumption analysis of data centre architectures," *Green Communications and Networking*, 2012.
- [40] J. Siu and S. K. Lopopolo, "Compatibility, sizing, and design considerations for generators and UPSs in tiers I, II, III, and IV topologies," *IEEE Trans. Ind. Appl.*, vol. 47, no. 6, pp. 2324-2329, Dec. 2011.

- [41] UI109110-411, “Accredited Tier Designer Technical Paper Series: Continuous Cooling,” *Uptime Institute*, LLC, 2011.
- [42] Raritan, “An Introduction to Data Centre Infrastructure Management,” Raritan Inc., 2010.
- [43] A. Hammadi, and L. Mhamdi “A survey on architectures and energy efficiency in Data Centre Networks,” *Computer Communications* vol.40 pp.1–21, 2014
- [44] R. Arno, A. Friedl, P. Gross, and R.J. Schuerger, “Reliability of Data Centres by Tier Classification,” *IEEE Trans. Industry Applications*, vol. 48, no. 2, pp. 777-783, Mar./Apr. 2012.
- [45] C. Yeh and M. Manjrekar, “A reconfigurable uninterruptible power supply system for multiple power quality applications,” *IEEE Trans. Power Electron.*, vol. 22, no. 4, pp. 1361–1372, Jul. 2007.
- [46] J. Park, J. Kwon, E. Kim, and B. Kwon, “High-performance transformer less online UPS,” *IEEE Trans. Ind. Electron.*, vol. 55, no. 8, pp. 2943–2953, Aug. 2008.
- [47] E. Sato, M. Kinoshita, Y. Yamamoto, and T. Amboh, “Redundant high density high-efficiency double-conversion uninterruptible power system,” *IEEE Trans. Ind. Appl.*, vol. 46, no. 4, pp. 1525–1533, Aug. 2010.
- [48] A. Nasiri, Z. Nie, S. Bekiarov, and A. Emadi, “An on-line UPS system with power factor correction and electric isolation using BIFRED converter,” *IEEE Trans. Ind. Electron.*, vol. 55, no. 2, pp. 722–730, Feb. 2008.
- [49] B. Zhao, Q. Song, W. Liu, and Y. Xiao, “Next-generation multi-functional modular intelligent UPS system for smart grid,” *IEEE Trans. Ind. Electron.*, vol. 60, no. 9, pp. 3602–3618, Sep. 2013.
- [50] J. Guerrero, L. Hang, and J. Uceda, “Control of distributed uninterruptible power supply systems,” *IEEE Trans. Ind. Electron.*, vol. 55, no. 8, pp. 2845–2859, Aug. 2008.
- [51] J. Taylor, J. Hutchinson, “Uninterruptible Power Supplies,” *CMP Media Inc, Powering the Next Millennium*, pp. 46-110, October. 1999.
- [52] J. Beaudet, J. Fiorina, and O. Pinon, “Pros and Cons of different UPS Topologies: passive standby, line interactive or double conversion,” *Power Quality Journal*, pp. 22-23. February, 2000.
- [53] V. Kontorinis, “Managing distributed UPS energy for effective power capping in data centres,” in *Proc. 39th Annu. Int. Symp. Comput. Architect.* pp. 488–499. 2012.

- [54] J. Guerrero, L. García de Vicuña, J. Uceda, "Uninterruptible Power Supply Systems Provide Protection," *IEEE Industrial Electronics Magazine*, vol. 1, No 1, pp. 28-38 April, 2007.
- [55] L. Giuntini, "Harmonics reduction in high-efficiency operation of double conversion UPS," in *Proc. European Conference on Power Electronics and Applications*, Birmingham, UK, Aug. Sep. 2011.
- [56] F. Cammarota, and S. Sinigallia, "High-Efficiency On-Line Double Conversion UPS," *Telecommunications Energy Conference (INTELEC)*, pp. 657-662, 2007.
- [57] M. Milad, and M. Darwish, "UPS System: How Can Future Technology and Topology Improve the Energy Efficiency in Data Centres," *The 49th International Universities Power Engineering Conference (UPEC2014)*, pp. 1-4. Cluj-Napoca, Romania 2-5 Sept, 2014.
- [58] M. Milad, And M. Darwish, UPS System: "Comparison between Double Conversion online UPS and Flywheel UPS Technologies in terms of efficiency and cost in a Medium Data Centre," *Presented in the 50th International Universities' Power Engineering Conference (UPEC 2015)*, pp. 1-5. Staffordshire University, UK, September 2015.
- [59] M. Ton and B. Fortenbury, "High performance buildings: data centres - Uninterruptible Power Supplies (UPS)," *Lawrence Berkeley National Laboratory, Final PIER-CEC Report*, Dec. 2005.
- [60] Uninterruptible power systems (UPS) Part 3: "Method of specifying the performance and test requirements" *International Standard IEC 62040-3*. March. 2011
- [61] D. Divan, R. Schneider, and D. Bielinski, "Industrial-strength sag correction," *Power Quality Mag.* Mar. 2002, Available: <http://ecmweb.com/power-quality-archive/industrial-strength-sagcorrection>.
- [62] A. Karpati, G. Zsigmond, M. Voros, and M. Lendvay, "Uninterruptible Power Supplies (UPS) for Data Centre," *IEEE 10th Jubilee International Symposium on Intelligent Systems and Informatics*, Sep. 2012.
- [63] L. Giuntini, "Efficiency in Data centres: High efficiency operating mode for double conversion UPS," *PCIM Conference*, 2011.
- [64] E. Kim, J. Kwon, and B. Kwon, "Transformerless three-phase on-line UPS with high performance," *IET Power Electronics*, vol. 2, pp. 103-112, 2009.
- [65] C. Yeh and M. Manjrekar, "A reconfigurable uninterruptible power supply system for multiple power quality applications," *Power Electronics, IEEE Transactions on*, vol. 22, pp. 1361– 1372, 2007.

- [66] J. Bitterly, "Flywheel technology past, present, and 21st Century projections," *Energy Conversion Engineering Conference*, 1997. IECEC-97., Proceedings of the 32nd Intersociety, vol.4, no., pp.2312- 2315 vol.4, 27 Jul-1 Aug 1997.
- [67] Z. Jiancheng, H. Lipei, C. Zhiye, and W. Su, "Research on flywheel energy storage system for power quality," *Power System Technology*, 2002. *Proceedings. International Power Conference 2002*. vol.1, no., pp. 496- 499 vol.1, 13-17. Oct, 2002.
- [68] S. Samineni, B. Johnson, H. Hess, and J. Law, "Modeling and analysis of a flywheel energy storage system for voltage sag correction," in *Electric Machines and Drives Conference*, pp. 1813-1818. June, 2003.
- [69] S. Karve, "Three of a kind UPS topologies, IEC standard," *IEE Review*, Volume 46, Issue 2, pp. 27-31, March 2000.
- [70] T. Siostrzonek, S. Pirog, and M. Baszynski, "Energy storage systems the flywheel energy storage," *Power Electronics and Motion Control Conference*, 2008. EPE-PEMC 2008. 13th, vol., no., pp.1779-1783, 1- 3 Sept. 2008.
- [71] F. Zhang, M. Tokombayev, Y. Song, and G. Gross, "Effective flywheel energy storage (FES) offer strategies for frequency regulation service provision," in *Proc. Power Syst. Comput. Conf.* pp. 1–7. Aug. 18–22, 2014.
- [72] R. Arghandeh, M. Pipattanasomporn, and S. Rahman "Flywheel energy storage systems for ride-through applications in a facility microgrid," *IEEE Trans. Smart Grid*, vol. 3, no. 4, pp. 1955–1962, Dec. 2012.
- [73] R. Lawrence, K. Craven, and G. Nichols, "Flywheel UPS," *IEEE Ind. Appl. Mag.*, vol. 9, no. 3, pp. 44–50, Jun, 2003.
- [74] R. Weissbach, G. Karady, and R. Farmer, "A combined uninterruptible power supply and dynamic voltage compensator using a flywheel energy storage system," *IEEE Trans. Power Del.*, vol. 16, no. 2, pp. 265–270, Apr, 2001.
- [75] Active Power, "Operation and Performance of a flywheel Based Uninterruptible Power Supply," [Online]. Available: http://www.activepower.com/documents/white_papers/ 2007.
- [76] C. DiMinico and J. Jew, (co-chairs), "Telecommunications Infrastructure Standard for Data Centres," *ANSI/TIA-942, In IEEE 802.3 HSSG Power Point*. April, 2005.
- [77] R. Focke, P. Schlattman and R. W. Weber, "What Tier 4 Emissions Rules for Backup Generators Mean," *In facilities net Building Operating Management*. October, 2009.
- [78] M. Ton, B. Fortenbury, "High Performance Buildings: Data Centres UPS," [Online]. Available: http://hightech.lbl.gov/documents/UPS/Final_UPS_Report.pdf. 2012.

- [79] C. Singh, A. Patton: “Reliability Evaluation of Emergency and Standby Power Systems,” *IEEE Trans. Industry Applications*, Vol.21, No.2, pp 1222-1227. Apr, 1985.
- [80] M. Rahmat, S. Jovanovic, K. Lo, “Reliability and Availability Modelling of Uninterruptible Power Supply Systems Using Monte-Carlo Simulation,” *International Review of Electrical Engineering (IREE)* vol. 1 NO 3, pp. 374 – 380. August, 2006.
- [81] J. Bentley, “Reliability & Quality Engineering,” *3rd Edition*, Addison-Wesley, 1999.
- [82] British Standards, BS 5760-2 (1994), “Reliability of Systems, Equipment and Components” *Part 2: Guide to the assessment of reliability*, 1994.
- [83] W. Torell, and V. Alevar, “Mean Time Between Failure” *Explanation and Standards*, White Paper No. 78, American Power Conversion Limited, 2004.
- [84] C. Singh, and N. Gubbala, “Reliability Analysis of Electric Supply including Standby Generators and an Uninterruptible Power Supply System,” *IEEE Transactions of Industry Applications*, Vol. 30, No. 5, pp 1298 – 1302, Sept/ Oct, 1994.
- [85] T. Tsumura, T. Takeda, K. Hirose: “A Tool for Calculating Reliability of Power Supply for Information and Communication Technology Systems,” *30th International Energy Conference (INTELEC 2008)*, Sept, 2008.
- [86] A. Villemeur, “Reliability, Availability, Maintainability and Safety Assessment,” *Volume 1*, John Wiley and Sons, 2000.
- [87] The Green Grid, “The Green Grid Data Centre Power Efficiency Metrics,” *PUE and DCIE White Paper No 6*, [Online]. Available: <http://www.thegreengrid.org/Global/Content/white-papers/The-Green-Grid-Data-Centre-Power-Efficiency-Metrics-PUE-and-DCIE>. 2007.
- [88] The Green Grid, “Usage and Public Reporting Guidelines for The Green Grids Infrastructure Metrics (PUE/DCiE),” *White Paper no- 22*, 2009.
- [89] C. Belady, A. Rawson, J. Pflueger, and T. Cader, “The Green Grid Data Centre Power Efficiency Metrics,” *PUE and DCIE*,” 2008.
- [90] Green Grid Metrics, “Describing Data centre Power Efficiency” *Technical Committee White Paper, The Green Grid*, February, 2007.
- [91] B. Whitehead, D. Andrews, A. Shah, and G. Maidment, “Assessing the environmental impact of data centres Part 1: Background, energy use and metrics,” *Building Environ.*, vol. 82, pp. 151–159, Dec. 2014.

- [92] S. Rivoire, M. Shah, P. Ranganathan, C. Kozyrakis, and J. Meza, “Models and metrics to enable energy-efficiency optimizations,” *Computer Conference*, vol. 40, no. 12, pp. 39–48, Dec. 2007.
- [93] The Green Grid “Recommendations for Measuring and Reporting Overall Data Centre Efficiency,” Version 2. Measuring PUE for Data Centres pp.1-12. 2008.
- [94] The Green Grid, “The Green Grid Metrics: Data Centre Infrastructure Efficiency Detailed Analysis2. White Paper No 14. [Online] www.thegreengrid.org/Global/Content/whitepapers/DCIE-Detailed-Analysis. 2008.
- [95] P. Mathew, S. Ganguly, S. Greenberg, and D. Sartor, “Self-benchmarking Guide for Data Centres: Metrics, Benchmarks, Actions,” 2009.
- [96] Emerson, “Maximizing Data Centre Efficiency, Capacity and Availability through Integrated Infrastructure,” *Whitepaper, Emerson*, pp.1-16. 2011.
- [97] Ashrae Datacom Series Book 9, Real-Time Energy Consumption Measurements in Data Centres, 2010. [Online]. Available: <https://www.ashrae.org/resources--publications/bookstore/datacom-series#9>. 2010
- [98] M. Wiboonrat, “Data Centre Design of Optimal Reliable Systems,” *Quality and Reliability (ICQR), IEEE International Conference on*, pp. 350-354. 2011.
- [99] The Green Grid, “PUE A Comprehensive Examination of the Metric” [Online]. Available: <http://www.thegreengrid.org/en/Global/Content/whitepapers/WP49>. White Paper 49-PUE. 2012.
- [100] Intel Intelligent Power Technology, Canalys, Shanghai, China, 2012. [Online]. Available: <http://www.canalys.com/newsroom/data-centreinfrastructure-market-will-be-worth-152-billion/> 2012.
- [101] S. Rivoire, “Models and metrics for energy-efficient computer systems,” *Ph.D. dissertation*, Dept. Elect. Eng., Stanford Univ., Stanford, CA, USA, 2008.
- [102] M. von dem Berge et al, “Modelling and simulation of data centre energy efficiency in cool mall,” in *Energy Efficient Data Centres*, vol. 7396, ser. Lecture Notes in Computer Science. Berlin, Germany: Springer, pp. 25–36. 2012.
- [103] A. Beloglazov, R. Buyya, Y. Lee, and A. Zomaya, “A survey of energy efficient data centres and cloud computing systems,” *Adv.* 2011
- [104] J. Wang, L. Feng, W. Xue, and Z. Song, “A survey on energy efficient data management,” *SIGMOD Rec.*, vol. 40, no. 2, pp. 17–23, September. 2011.

- [105] G. Christopher, "Data Centre Life Cycle Assessment Guidelines," *Whitepaper no 45, V2, The Green Grid*, pp.1-28. 2012.
- [106] R. John, "Data Centre Strategies: Simplifying high stakes, mission critical decisions in a complex industry", *Data Centre Knowledge*, pp.1-26. July 2011.
- [107] L. Ganesh, H. Weatherspoon, T. Marian, and K. Birman, "Integrated Approach to Data Centre Power Management," *Computers, IEEE Trans. on Computers*, vol. 62, no. 6, pp. 1086, 1096. June, 2013.
- [108] H. Sun, and S. Lee, "Case study of data centre energy performance," *Energy and Buildings 38*, pp.522–533. 2006.
- [109] Y. Jumie, and R. Mehdizadeh, "A critical analysis of Power Usage Effectiveness and its use in communicating data centre energy consumption," *Energy and Buildings 64* pp.90–94. 2013.
- [110] M. Patterson. "The effect of Data Centre temperature on energy efficiency", *ITHERM 2008 Conference*, pp.1167-1174, May, 2008.
- [111] L. Zhou, and Z. ping Qi, "Modelling and Control of a Flywheel Energy Storage system for Uninterruptible Power Supply," *IEEE. International Conference on Sustainable Power Generation and Supply*. pp. 978-1-4244-4934-7, 2009
- [112] C. Junling, J. Xinjian, Z. Dongqi and W. Haigang "A Novel Uninterruptible Power Supply using Flywheel Energy Storage Unit," *IEEE. Power electronics and motion control conference*, vol. 3, pp. 1180-1184, 2004.
- [113] C. Yeh and M. Manjrekar, "A reconfigurable uninterruptible power supply system for multiple power quality applications," *IEEE Trans. Power Electron.*, vol. 22, no. 4, pp. 1361–1372, Jul. 2007.
- [114] N. Vázquez, J. Saucillo, C. Hernández, E. Rodríguez, and J. Arau, "Two-stage uninterruptible power supply with high power factor," *IEEE Trans. Ind. Electron.*, vol. 55, no. 8, pp. 2954–2962, Aug. 2008.
- [115] B. Zhao, Q. Song, W. Liu, and Y. Xiao, "Next-generation multi-functional modular intelligent UPS system for smart grid," *IEEE Trans. Ind. Electron.*, vol. 60, no. 9, pp. 3602–3618, Sep. 2013.
- [116] Y. Guo and Y. Fang, "Electricity cost saving strategy in data centres by using energy storage," *IEEE Trans. Parallel Distributed. Syst.*, vol. 24, no. 6, pp. 1149–1160, Jun. 2013.
- [117] L. Haijin, Z. Wenping, and X. Dehong, "High-reliability longbackup- time super UPS with multiple energy sources," *Energy Conversion Congress and Exposition (ECCE), 2013 IEEE*, vol., no., pp.4926, 4933, 15-19. Sept. 2013

- [118] A. Emadi, A. Nasifi and S. Bekiarov, “Uninterruptible power supplies and active filters”, *CRC Press*, 2005.
- [119] R. Lawrence, K. Craven, and G. Nichols, “Flywheel UPS,” *IEEE Ind. Appl. Mag.*, vol. 9, no. 3, pp. 44–50, Jun. 2003.
- [120] R. Hebner, J. Beno, and A. Walls, “Flywheel batteries come around again,” *IEEE Spectr*, vol. 39, no. 4, pp. 46–51, Apr. 2002.
- [121] R. BROWN Daryl and D. CHVALA, "Flywheel Energy Storage An alternative to batteries for uninterruptible power supply systems," *Pacific Northwest National Laboratory, ETATS-UNIS*, Richland, Washington, US, 2004.
- [122] L. Zhou and Z. Qi, “Modelling and control of a flywheel energy storage system for uninterruptible power supply,” in *Proc. Int. Conf. Sustainable Power Generator Supply*, pp. 1-6. 2009.
- [123] Reliability assessment of integrated flywheel UPS vs. double conversion UPS with batteries Active Power Inc., Austin, TX, White paper 103, 2008.
- [124] Active Power Inc., “Understanding flywheel energy storage: Does high speed really imply a better design?” Austin, TX, Tech. Rep., White Paper 112, 2008.
- [125] T. Siostrzonek, A. Penczek, and S. Pirog, “The control and structure of the power electronic system supplying the flywheel energy storage (FES),” in *Proc. 2007 Eur. Conf. Power Electron. Appl.*, Aalborg, Denmark, pp. 1- 6. 2007.
- [126] X. Zhan and S. Reda. “Techniques for energy-efficient power budgeting in data centres,” *In Proceedings of DAC*, page 176. ACM, 2013.
- [127] Z. Liu, I. Liu, S. Low, and A. Wierman. “Pricing data centre demand response,” *In ACM SIGMETRICS*, 2014.
- [128] R. Wang, N. Kandasamy, C. Nwankpa, and D. R. Kaeli. “Data centres as controllable load resources in the electricity market,” *In Intl. Conf. on Distributed Computing Systems*, 2013.
- [129] R. Weidmann and H. Vogel, “Data centre 2.0: Energy-efficient and sustainable,” in *The Road to a Modern IT Factory*, ser. Management for Professionals, F. Abolhassan, Ed. Berlin, Germany: Springer-Verlag, pp. 129–136. 2014.
- [130] A. Orgerie, M. de Assunc, and L. Lefevre, “A survey on techniques for improving the energy efficiency of large-scale distributed systems,” *ACM Comput. Surv*, vol. 46, no. 4, pp. 47:1–47:31, June. 2013.