

Data Extraction for Underwater Particle Holography

Henry Nebrensky (Brunel University)

HOLOMAR

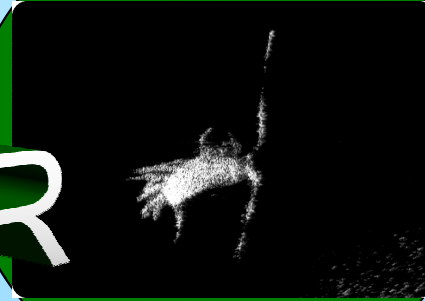

**High resolution *in situ* HOLOgraphic
recording and analysis of MARine
organisms and particles**



EC MAST-III Programme
MAS-CT97-0079



The need to study marine organisms

- **Behaviour of marine biological communities**
 - plays important role in understanding global environment
 - e.g. atmospheric interactions {global warming}
 - e.g. biological interactions {fisheries, algal blooms}
- **Modelling of chemical cycles** assisted by
 - study of aggregates of biotic or abiotic particles
 - knowledge of distribution & interaction dynamics
 - the **inter-relationships** between various organisms
- **Accuracy of measurements limited**
 - absence of good measurement techniques
 - counters, sampling bottles or photography
 - frailty & wide size range & complexity of aggregates
 - particles vary in size from sub-micron to several millimetres



The benefits of holography in marine biology

- **Records live species in natural environment**
 - non-intrusive, non-destructive, *in situ* interrogation
 - can record large volumes of water column in one short exposure
- **True three-dimensional imaging of organisms**
 - retention of parallax & perspective information
 - high image resolution over large depth-of-field
 - wide recording dynamic range
- **Ability to isolate individual planes of the image**
 - move viewing plane through image volume to bring individual species into focus
- **Aids study of marine biological communities**
 - measurement of distribution of organisms & interrelationships
 - measurement of size & relative position of organisms
 - species identification & classification at genus level



Off-axis holography: replay of real (projected) image

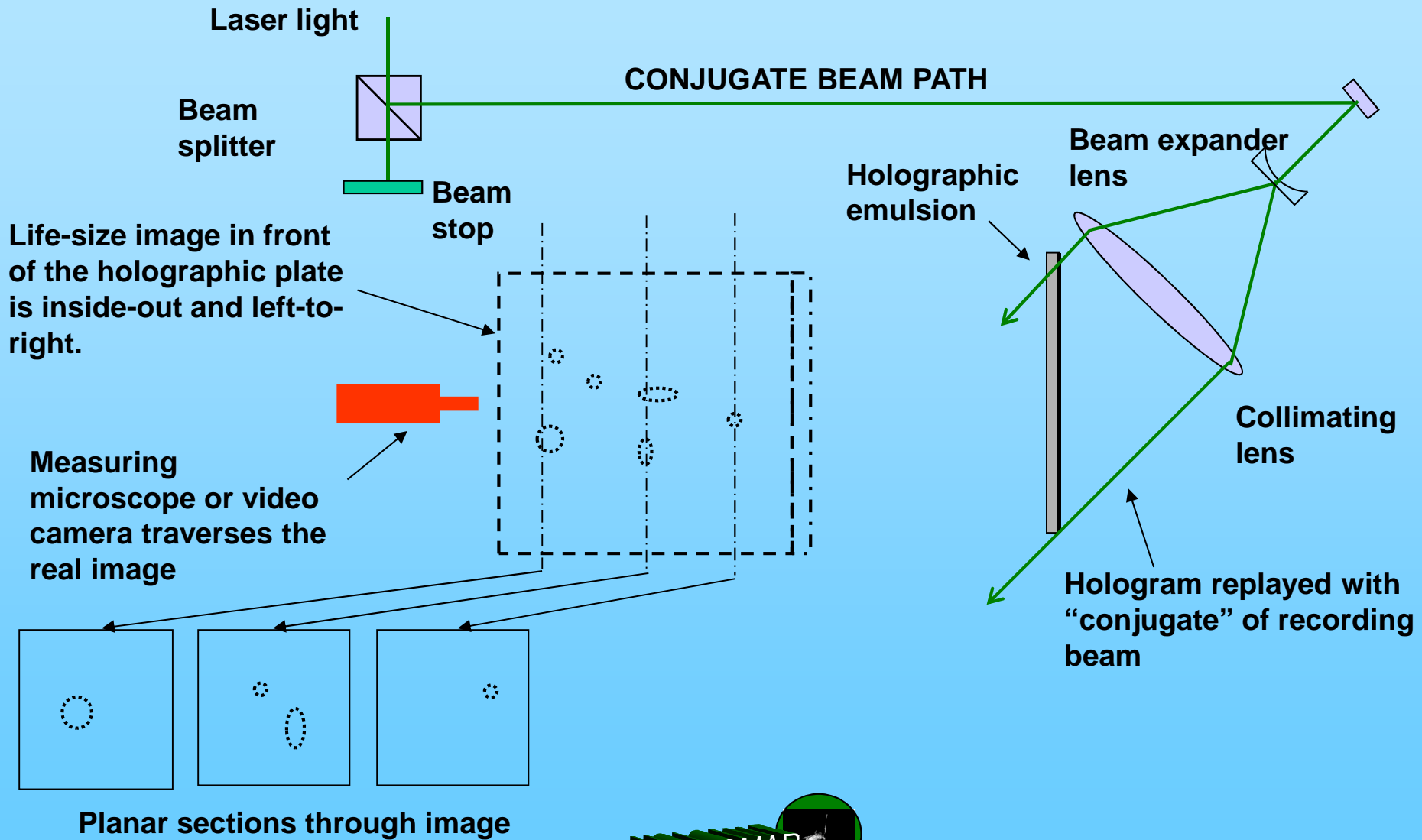

Objectives of HoloMar

- **Develop, construct & evaluate a fully-functioning prototype underwater holographic camera**
 - Holographically record large volumes of the upper water column containing marine plankton & seston
- **Design, develop & construct a fully-functioning hologram replay facility**
 - Replay holograms in the real image mode for high resolution inspection & measurement
- **Record, analyse & interpret holograms using specially developed image processing algorithms**
 - Identification of species, size, relative location & distribution of marine organisms without operator intervention



HoloCam recording volume

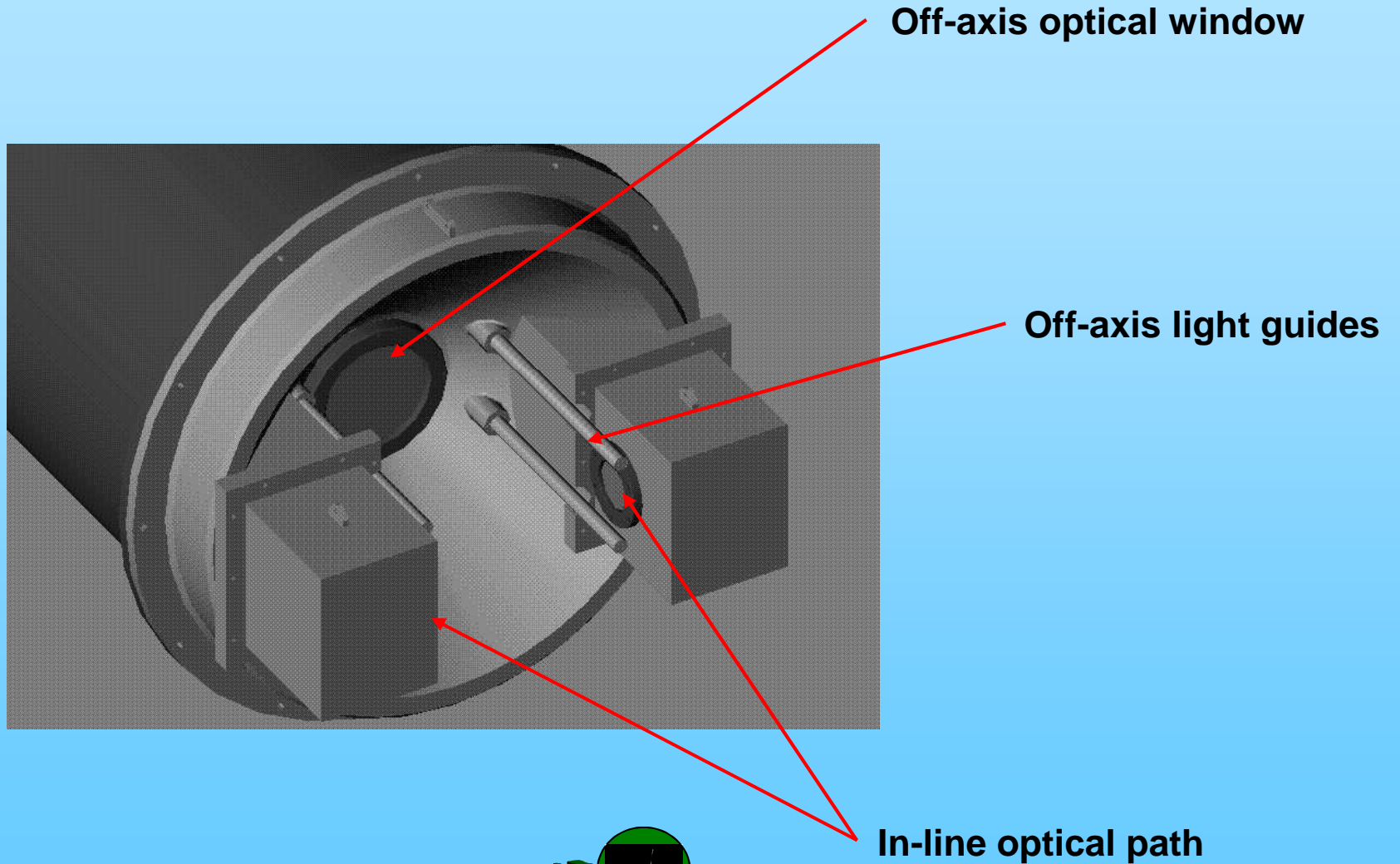

Loch Etive study site October 2001

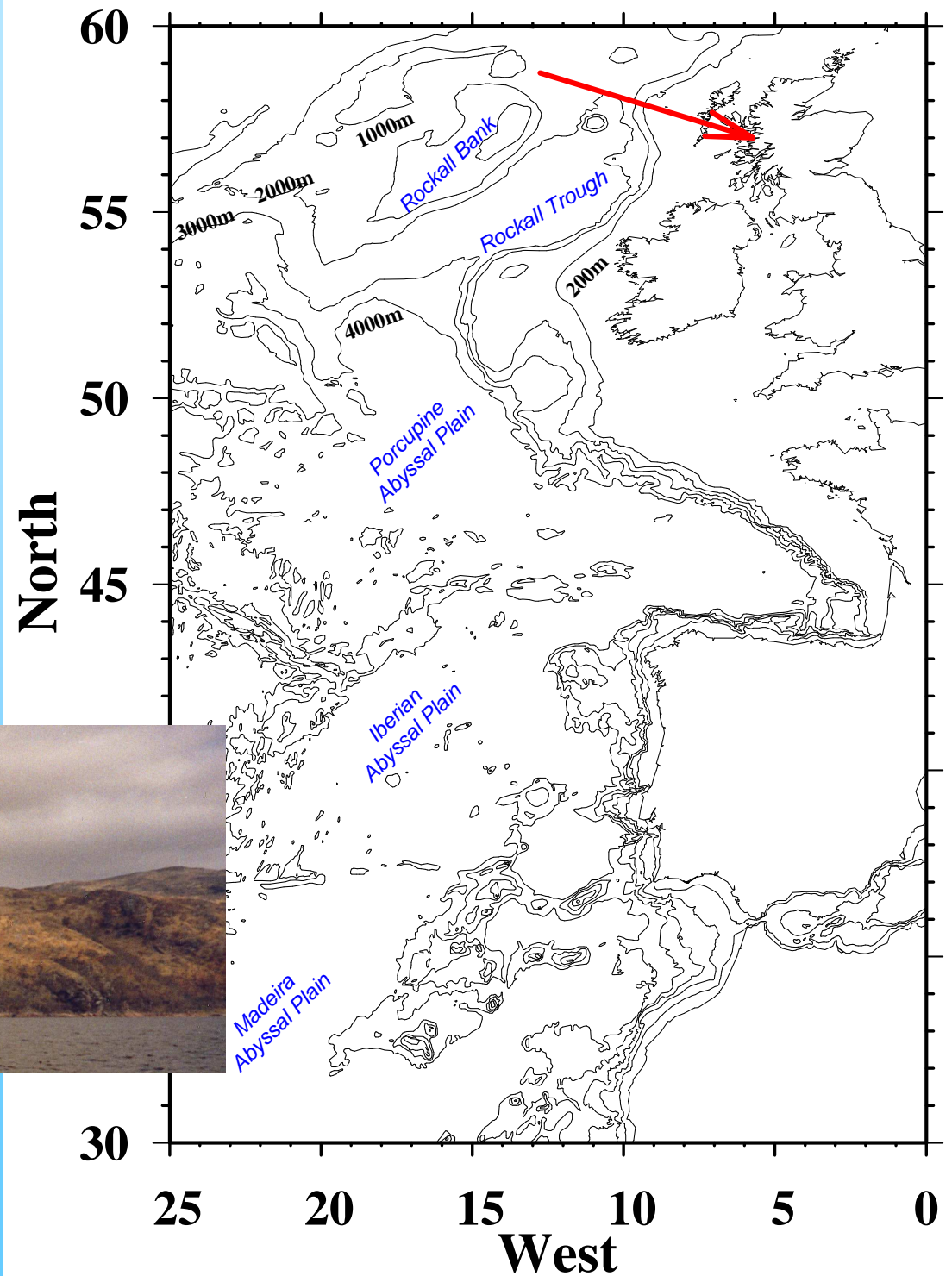

HoloCam launch from the R.V. Calanus



HoloScan replay facility

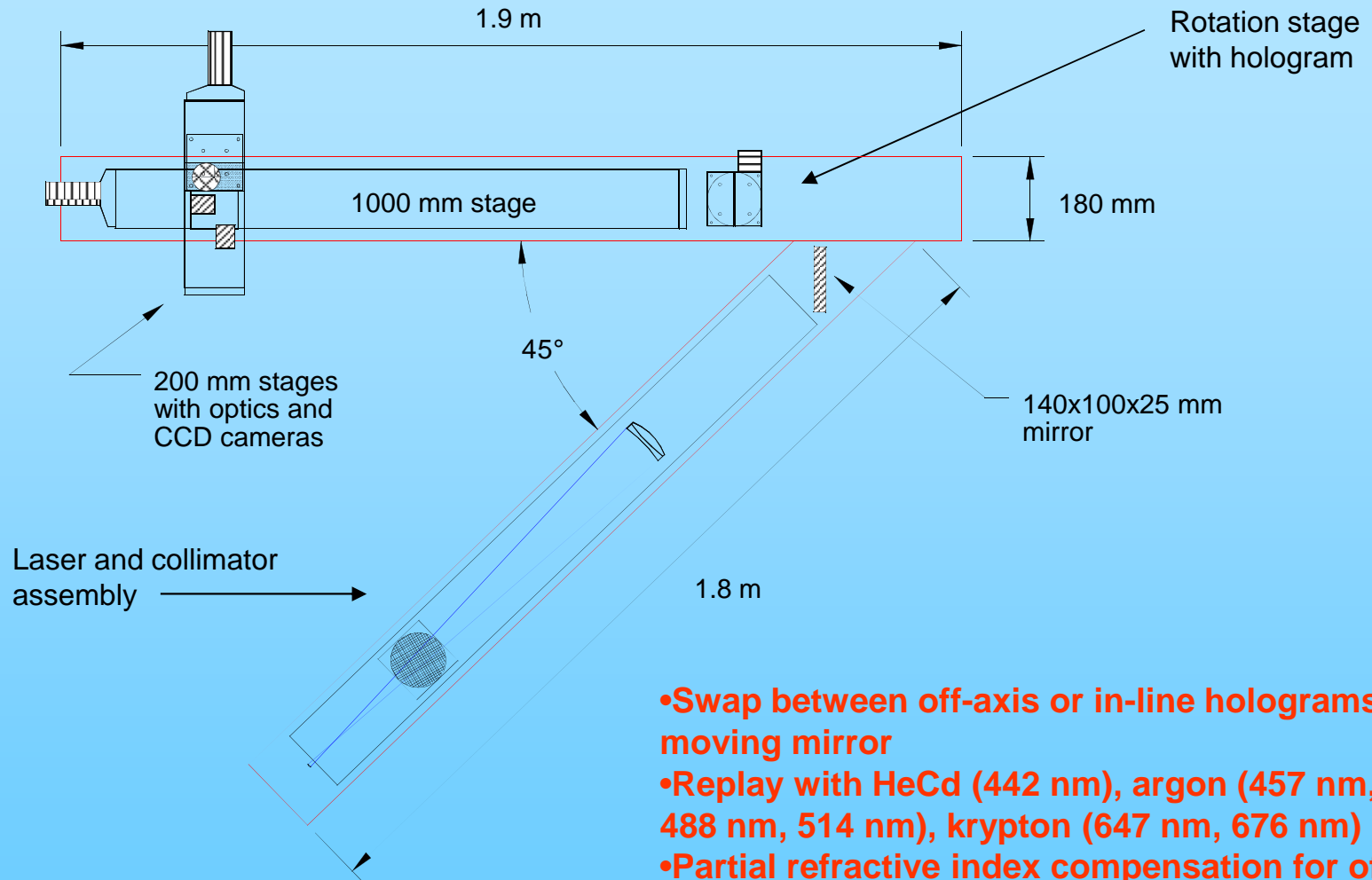

- Swap between off-axis or in-line holograms by moving mirror
- Replay with HeCd (442 nm), argon (457 nm, 488 nm, 514 nm), krypton (647 nm, 676 nm)
- Partial refractive index compensation for off-axis holograms



Data acquisition & image processing

Steps (automated):

- **Global adjustment of hologram for brightest and sharpest image**
 - orientation of plate holder and angle of reference beam
- **Scan videocamera through depth; capture successive images**
- **Digital processing for image enhancement**
 - cleaning and background removal
 - object tracking
 - best focus
 - image enhancement
 - segmentation
- **Species identification**
 - based on neural networks recognition

Results:

- **Size measurement & relative position**
- **Measurement of local concentration and distribution by category**



HoloScan replay facility



Denizens of Loch Etive

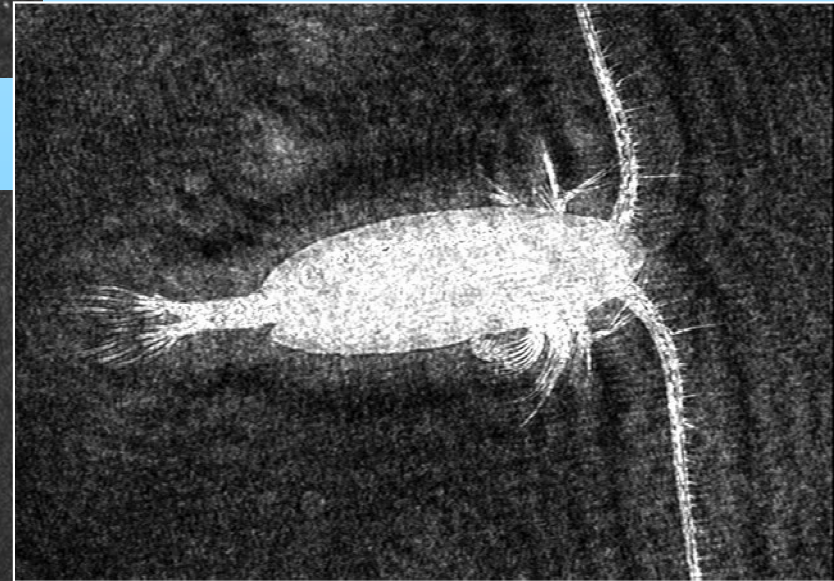
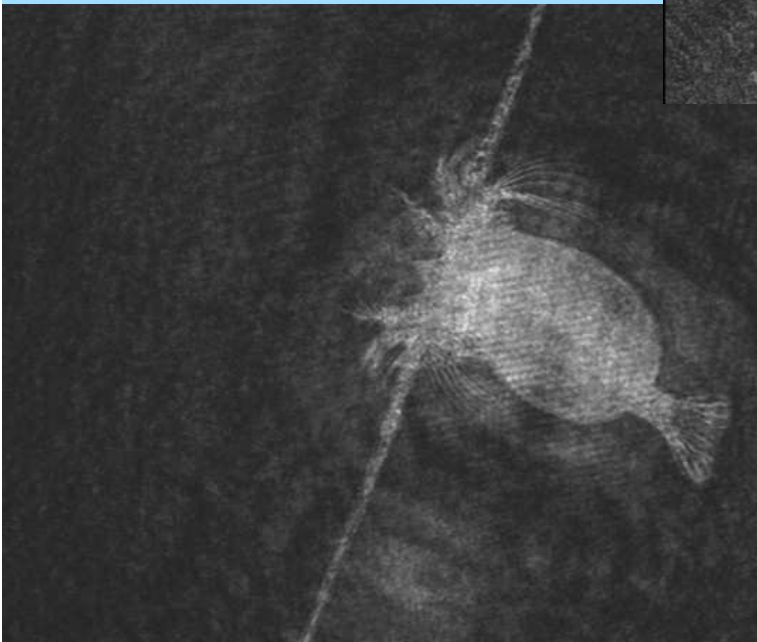
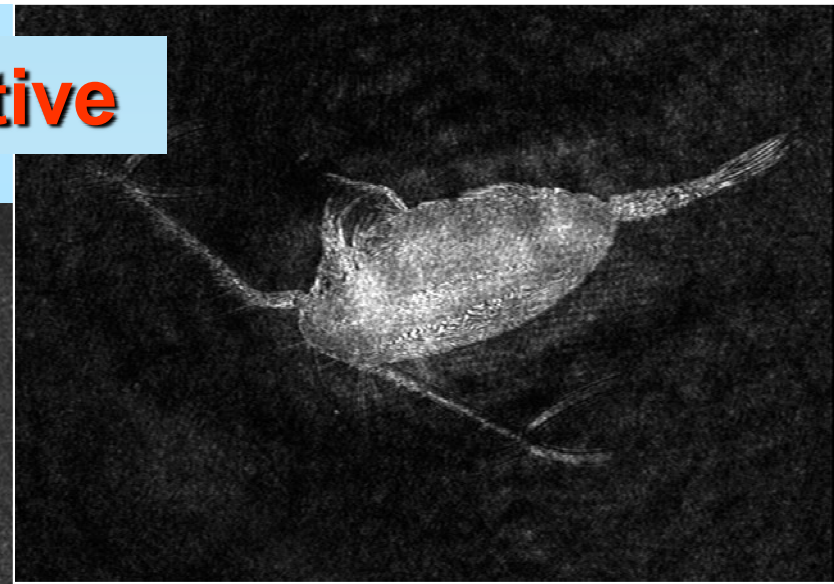
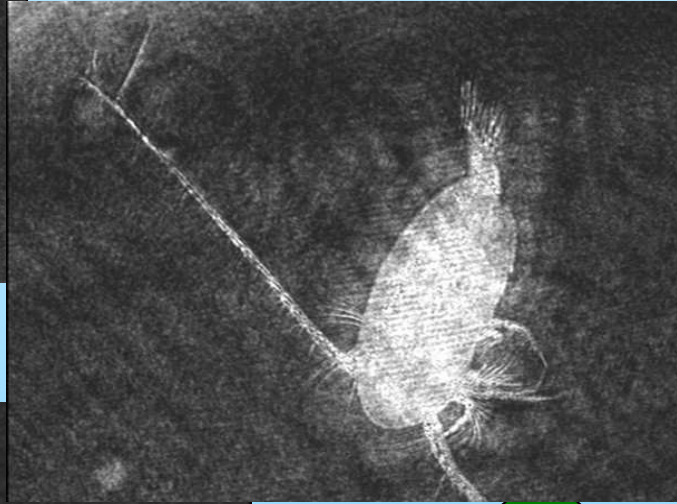
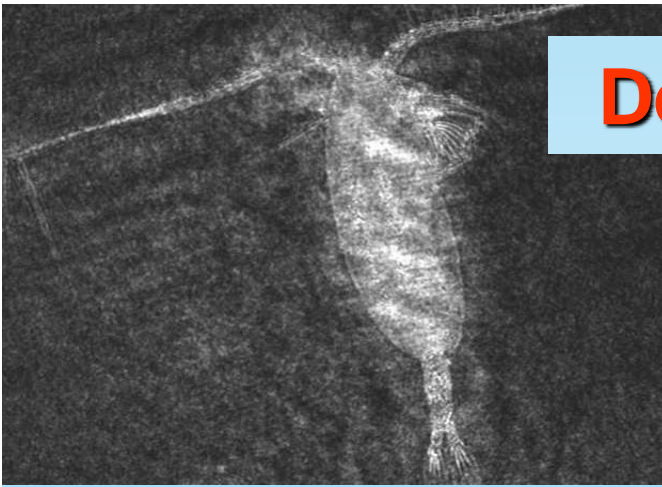

Calanus finmarchicus from holograms at 70 m; 2 mm long and located several tens of centimetres from the exit window.

Distribution of “targets” around copepods

**Interactions Between Meso- and Micro-
Plankton: Deductions From Fine Scale
Distributions in Three Dimensions Obtained
Using In Situ Holography.**

R.S. Lampitt, P.R. Hobson, X. Irigoien,
M.A. Player, K. Saw, K. Tipping, J. Watson
and J.J. Nebrensky.

EOS Transactions, American Geophysical Union.
Vol 83 No 4 . 22 January 2002. p 84

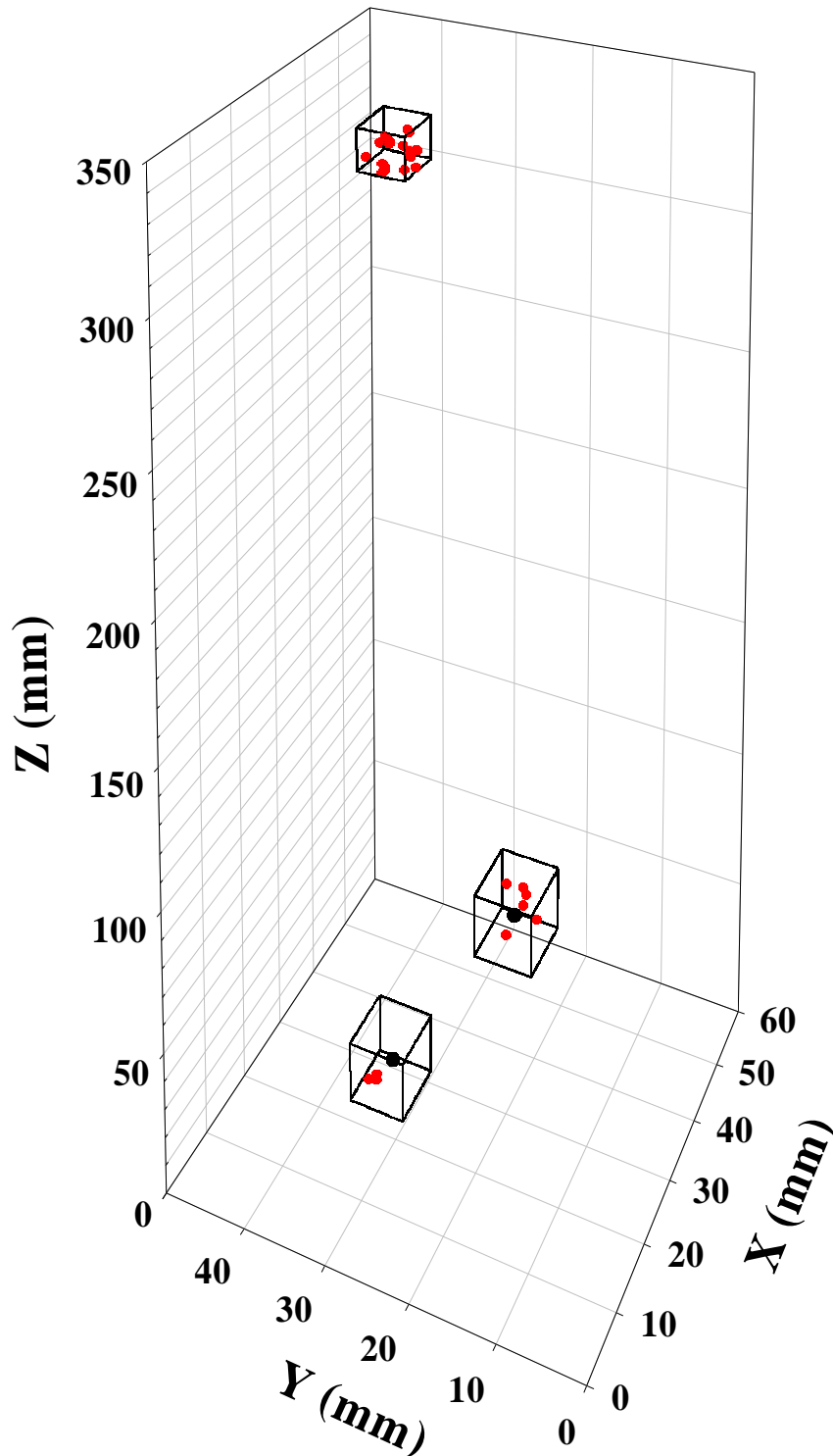

In-line Holograms of Floccs

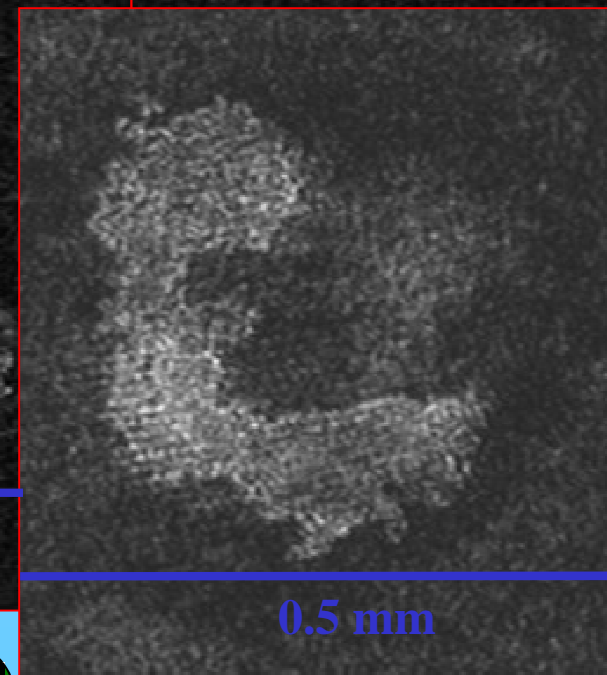
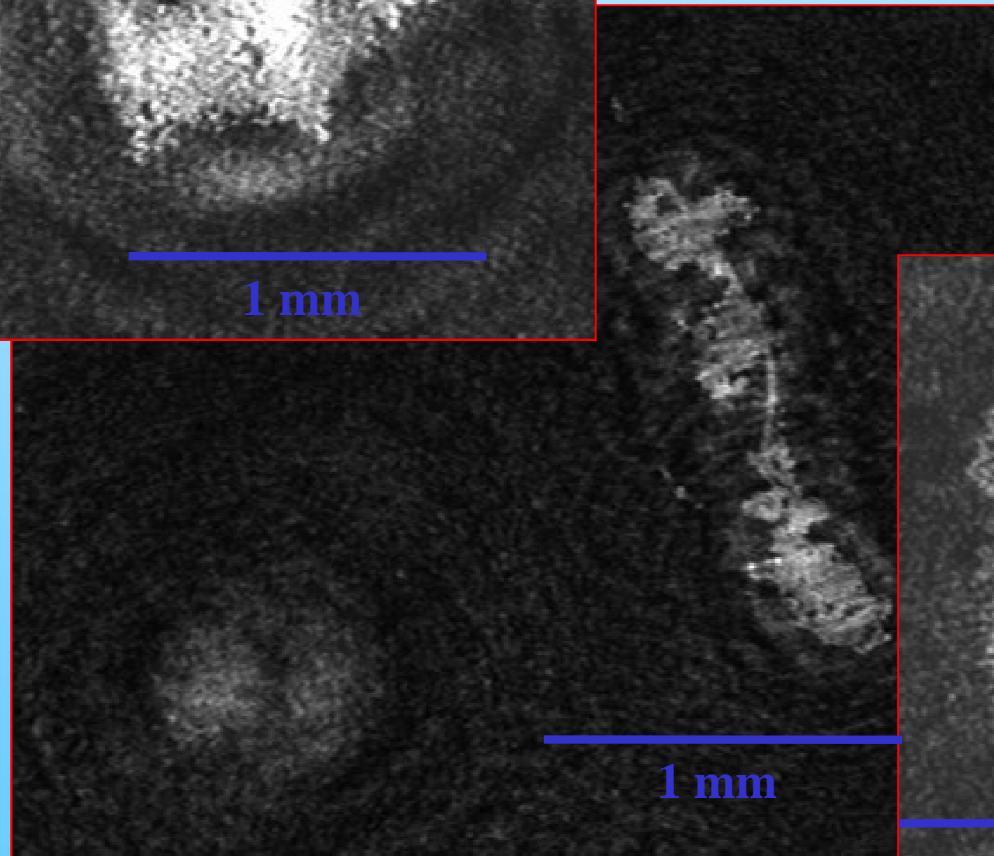
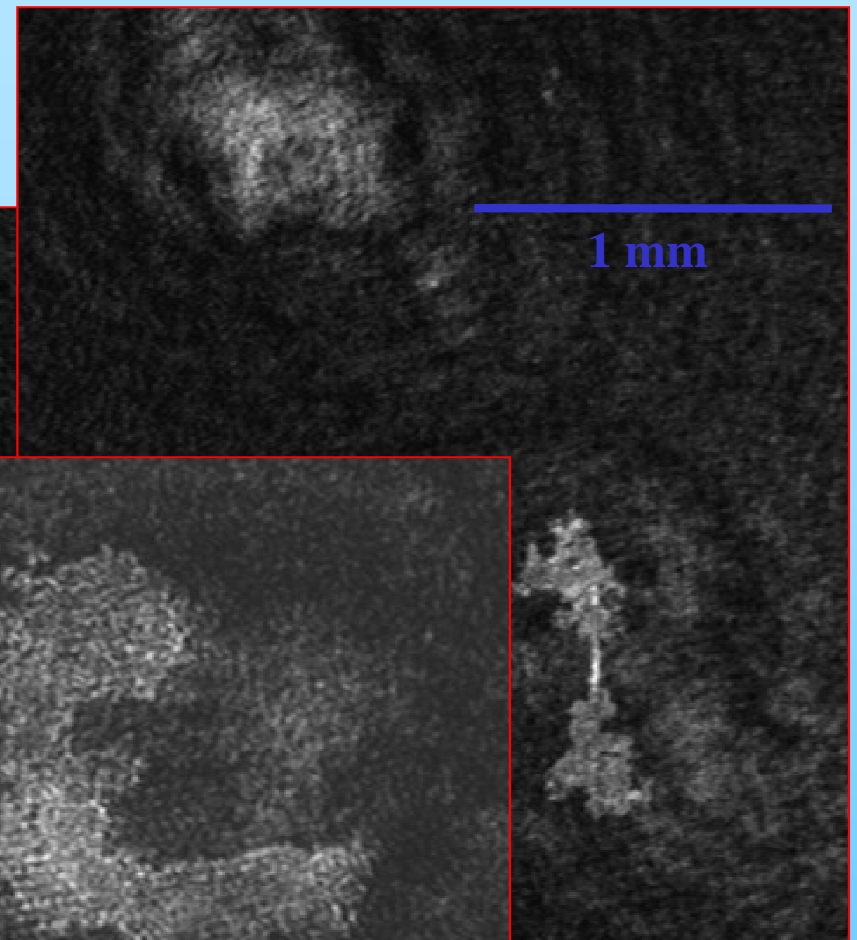
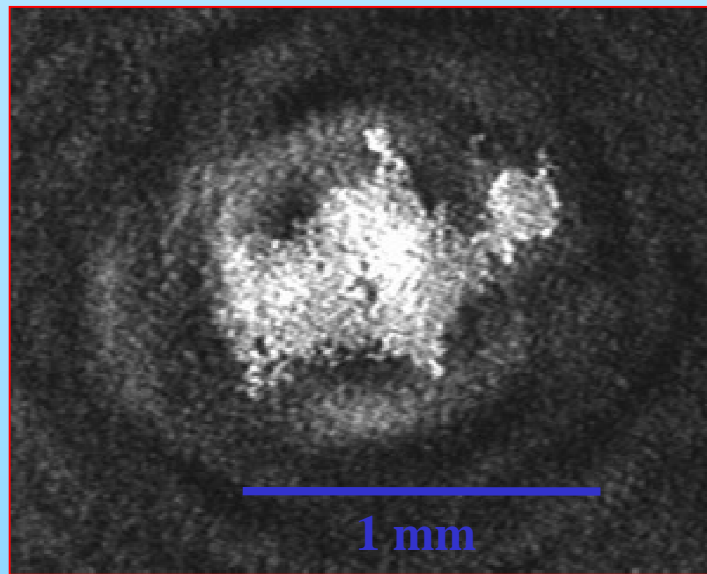

Marine snow aggregate (0.5mm diameter)

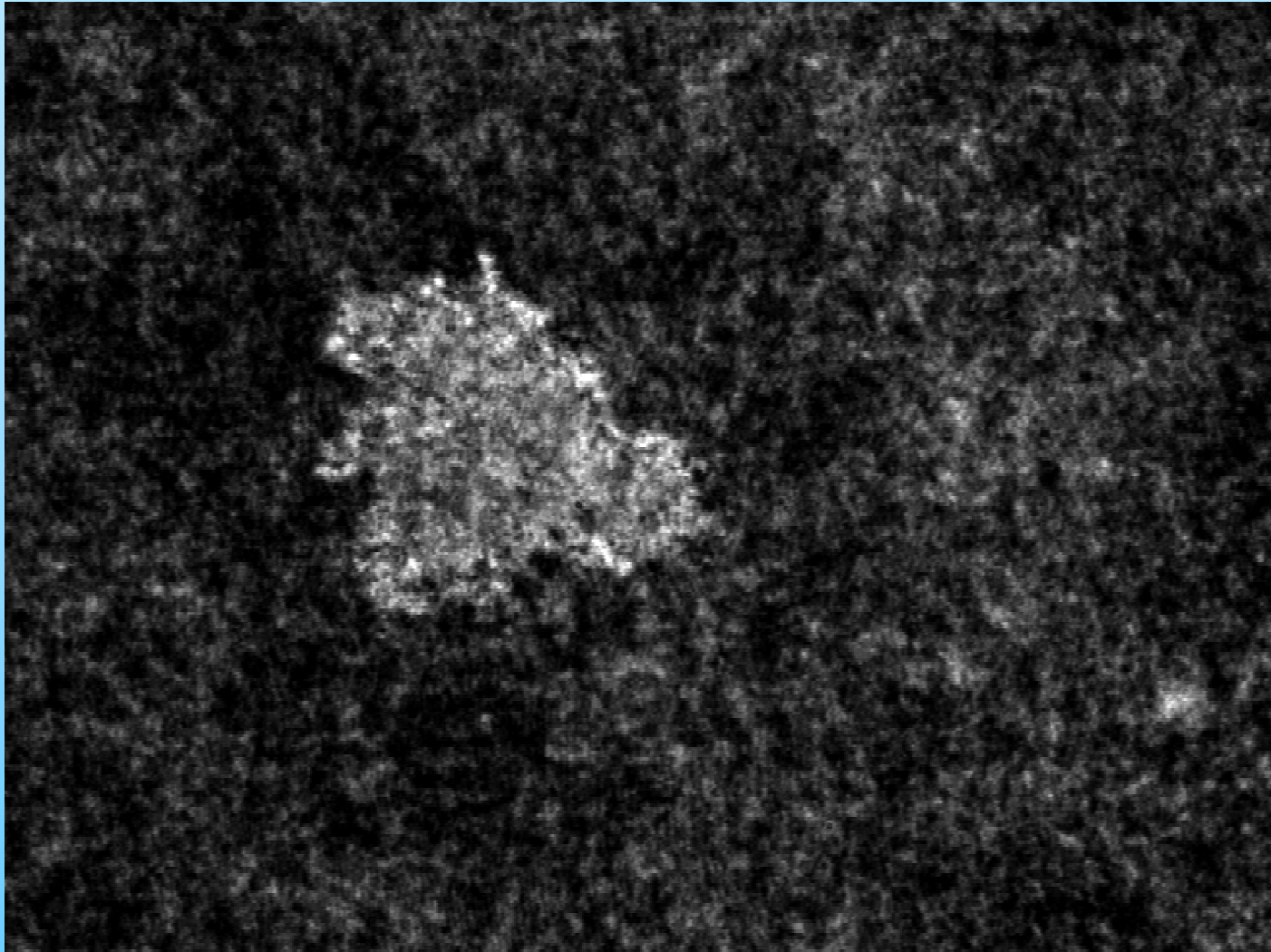

Related hologrammetry applications

High-resolution imaging & measurement in 'dense' media:

- **Offshore inspection**
 - archiving, corrosion pitting, damage, dimensional measurement
- **Nuclear fuel inspection**
- **Bubble chamber diagnostics** - analysis of nuclear particle tracks
- **Marine life, organisms, bubble fields**
 - recording / monitoring of coral reefs
 - sediment transport / tracking
 - cavitation nuclei
- **Separation processes - crystallisation, flocculation/sedimentation**
- **3-d micrography of human eye**
- **Sampling from ice cores**
 - pollen, micro-meteorites, mammoths
- **Objects trapped in amber**

Other particle analysis:

- **Combustion processes & liquid atomisation**
 - water droplets, aerosols, clouds, snow and fog
- **Insect swarms**



The Holographic Data Problem

If a photograph is worth a thousand words, then a hologram is worth a million photographs
(after Keith Pennington)

- Our in-line sample volume is 100 mm diameter and 0.5 m long
- The *low*-magnification camera has a field of view about 9 by 6 mm
- That's around 200 images for each slice
- Even assuming a slice every 0.1 mm (bigger than many objects)
 - **A million images in each holographic plate**



The Holographic Data Problem

Manual or semi-automatic analysis generally takes about a person-week for each holographic exposure

- Brown (ice crystals in clouds) - “a few hours” for a 150 cm³ sample volume
- Borrmann & Jaenicke (snow / fog) - 32 hours / hologram: 8 cm³ and 1000 objects
- Vössing *et al.* (snow / fog) - up to 70 hours for 1 hologram of a 500/ volume
- Katz *et al.* (plankton) - two weeks for each hologram of 300 to 2000 cm³

The main issue is operator fatigue leading to measurement errors

Automated analysis is needed ...



The Holographic Data Problem

... but still a challenge

At *high* magnification (a 1 mm by 0.7 mm view), one plate can generate **30 TeraBytes** of raw data

- Need to extract information, not data
- How does one characterise the 3-d, projected real image ?
 - e.g. brightness and contrast: how to find the brightest and darkest voxels in that 30 Tb?
 - Real image properties both fixed in plate and depend on replay laser and viewing camera



Digital Holography

Instead of using photographic film, it is possible to capture the hologram directly on to the CCD, and then reconstruct numerically within a computer.

This avoids the need to handle glass plates within the holocamera, and eliminates chemical development.

Numerical reconstruction is computationally heavy - multiple FFTs.

Marc Fournier-Carrié, a Socrates student, has implemented reconstruction software for single image planes from in-line holograms for his lab project.

The system is written in C++ on Linux.

Digital Holography

Sample results obtained from an array of pairs of opaque discs by Marc Fournier-Carrié:

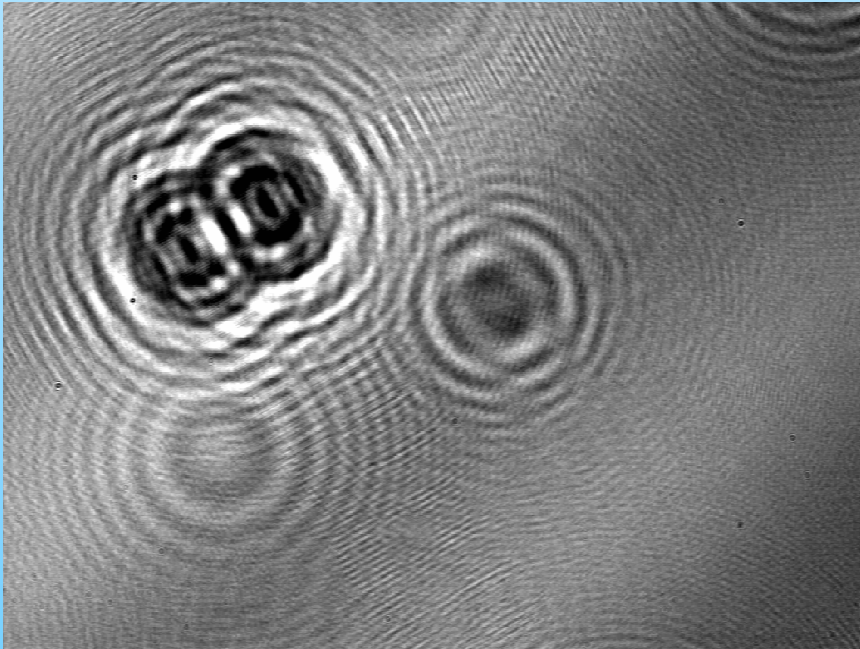

An in-line hologram of a test target, captured from a CCIR videocamera

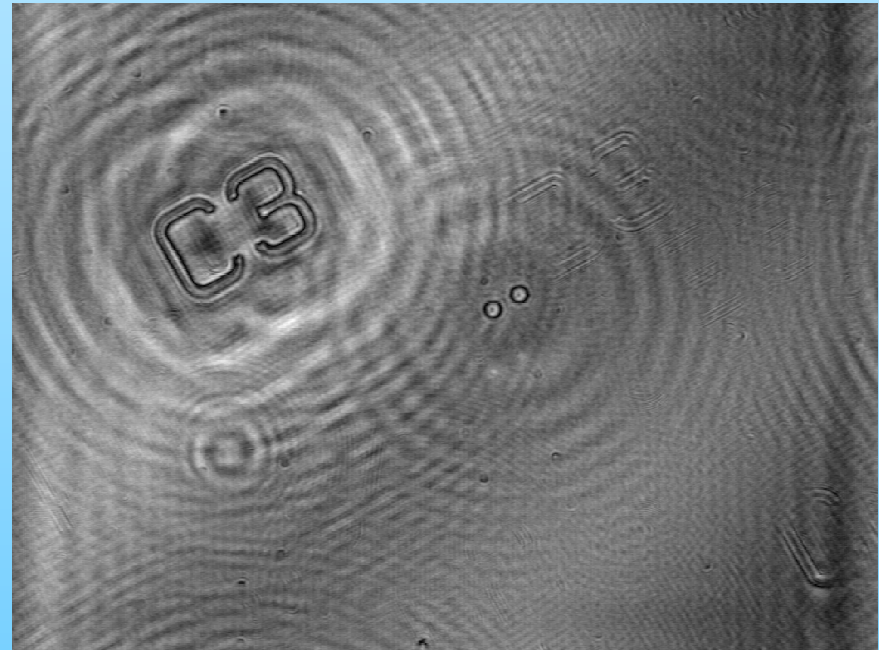

The in-focus objects, regenerated within the computer

Further Work

- **Effects of Humidity on holographic emulsions**
- **Digital Holography: recording of holograms**
 - Sensors
 - Optics
 - Integration
 - **BITLab holography facility**
- **Digital Holography: numerical reconstruction**
 - Use of DC and Grid for number crunching
- **Visualisation**
 - **BITLab**
- **Open-source release of HoloBatch code**

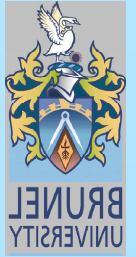

The Partners wish to thank the European Commission (MAST III Programme) for funding the HOLOMAR Project

CO-ORDINATOR: John Watson

Department of Engineering, Aberdeen University, Aberdeen AB24 3UE, Scotland

COLLABORATORS

- *Aberdeen University, SCOTLAND*
 - *Holo 3, FRANCE*
 - *Quantel, FRANCE*
 - *University of Udine, ITALY*
 - *Brunel University, ENGLAND*
- *Southampton Oceanography Centre, ENGLAND*
 - *University of Genova, ITALY*



HOLOMAR web site: <http://www.brunel.ac.uk/~eestprh/holopub/sld001.htm>



The End