

Optimised Cold-Formed Steel Beams in Modular Building Applications

Perampalam Gatheeshgar

Faculty of Engineering and Environment, Northumbria University,
Newcastle upon Tyne, UK.

Keerthan Poologanathan

Faculty of Engineering and Environment, Northumbria University,
Newcastle upon Tyne, UK.

Shanmuganathan Gunalan

School of Engineering and Built Environment, Griffith University,
Gold Coast, QLD, Australia.

Konstantinos Daniel Tsavdaridis

School of Civil Engineering, Faculty of Engineering, University of Leeds
Leeds, UK.

Brabha Nagaratnam

Faculty of Engineering and Environment, Northumbria University,
Newcastle upon Tyne, UK.

Eleni Iacovidou

Institute of Environment, Health and Sciences, College of Health and Life Sciences, Brunel
University London, London, UK.

Abstract

Modular Building Systems (MBS) has seen an accelerating growth in the construction sector owing to its potential advantages, such as quick erection, improved energy efficiency and less reliant on good weather over conventional construction methods. Therefore, it could be a viable solution to supporting the efforts of solving Britain's housing crisis within a short duration. Construction industries and researchers are working towards better understanding MBS performance at different scales and contexts. To date, research on MBS focused on investigating the structural, social and economic, and safety performances and indicated that there are challenges (Need of lightweight materials and more access space, transportation restrictions, improving structural, fire and energy performances) associated with their use, yet to be addressed. This paper highlights how the incorporation of optimised Cold-Formed Steel (CFS) members with the slotted web can address these challenges. Hence, optimisation technique was employed to enhance the structural performance and to effectively use the given amount of material of CFS members. Lipped channel, folded-flange, and super-sigma have

37 been optimised using the Particle Swarm Optimisation (PSO) method and were analysed using
38 FEM. Results showed that the flexural capacity of the optimised sections was improved by 30-
39 65% compared to conventional CFS sections. A conceptual design of MBS was developed
40 using the optimised CFS members, demonstrating the potential for lighter modules and thus
41 more sustainable structures, reducing the carbon footprint. Therefore, optimisation techniques
42 and slotted perforations would address the aforementioned challenges related to MBS, result
43 in more economical and efficient MBS for inhabitants and construction industries.

44 *Keywords:* Modular Construction and Challenges, Cold-Formed Steel, Innovative Sections
45 with Slotted Web, Particle Swarm Optimisation, Finite Element Analyses, Conceptual Design

46 **1 Introduction**

47 Modular construction, also known as off-site construction, is a process where individual
48 modules manufactured off-site are subsequently transported and assembled on-site. By the use
49 of this method more than three-quarters of the construction phase is completed off-site,
50 generating environmental and economic savings [1, 2]. MBS has recently attracted a lot of
51 attention due to its numerous advantages of speed erection, improved quality, reduced waste
52 generation, reduced cost, improved sustainability, less on-site noise generation as described in
53 many studies [1-3, 5-12]. Among the MBS advantages, the reduced construction time over
54 conventional construction methods has gained the attention of the UK government and
55 construction industry alike, for meeting the huge undersupply of housing in the UK. In 2017/18,
56 the UK provided 222,000 new houses, 2% higher than the previous year, lower than the annual
57 average (see Figure 1). However, recent studies [1, 8-10] focused on investigating the
58 structural, social and economic, and safety performances of MBS and found that still there are
59 challenges associated with their use. The major reported challenges are regarding project
60 planning, structural response/performance, fire and energy performance, transportation
61 difficulty, reliable connection systems, lifting limit of tower cranes, lightweight and high-
62 performance materials, lack of access during renovation and lack of design guidelines, that
63 need to be overcome to make the MBS construction viable.

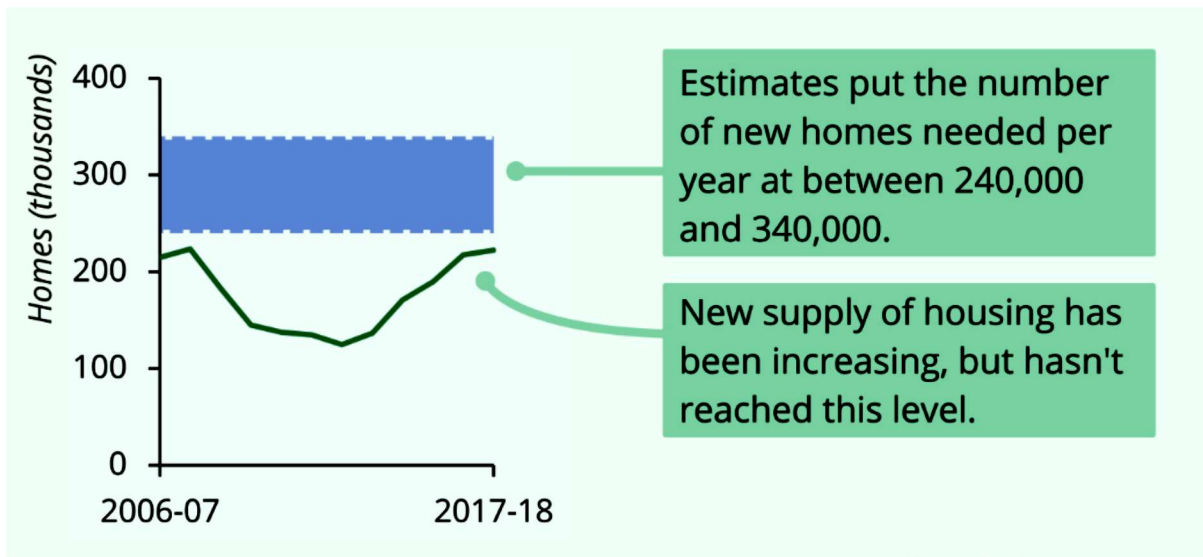

65

66

Figure 1: The housing supply in the UK recent years [5]

67 Most of the reported challenges can be addressed when MBS is mainly constructed with
68 optimised CFS sections. Optimisation technique can play a vital role to meet the challenges
69 related to MBS as it offers enhanced structural performance for a given amount of material.
70 Moreover, material (steel) can be effectively used and the manufacturers will also experience
71 the benefit in terms of the usage of reduced raw material. Currently available industry sections
72 are different in dimensions when compared with a basic of the same amount of material used.
73 This may be due to the capability of forming and press braking machines used by different
74 manufacturers. Thus currently available industry CFS sections are likely to be inefficient in
75 terms of structural capacity and material usage perspective. The recent sophisticated
76 advancements in manufacturing technologies allow flexibility in manufacturing profiles. Due
77 to these advancements, rollers used in roll-forming techniques could be adjustable to form
78 optimised sections with different shapes and dimensions. It will lead to additional cost per
79 meter length for innovative profiles, however, the mass production and efficient material
80 design compensate for the additional cost.

81 To date, Several optimisation techniques, neural networks [11], Genetic Algorithm (GA) [12-
82 14] and Particle Swarm Optimisation (PSO) [15-17] have been successfully employed to
83 optimise the CFS beams. Moreover, incorporating staggered slotted perforations to the CFS
84 channels can enhance the thermal performance of the channel [18]. However, the slotted
85 perforations in CFS channels reduce structural performance. Incorporating slotted perforations
86 to the optimised CFS sections and employing them into MBS would amplify the overall
87 performance of the MBS. Limited research has been performed related to employing optimised

88 novel CFS beams into MBS. Gatheeshgar et al. [19] introduced the concept of employing
89 optimised hollow flange beams into MBS to enhance the structural performance of MBS and
90 no research has been performed on employing optimised CFS beams without and with slotted
91 perforations into MBS.

92 Therefore, this paper presents the concept of employing optimised CFS beams without and
93 with slotted perforations into MBS and investigates their potential in addressing the
94 aforementioned challenges. The novel CFS sections were optimised using PSO in order to
95 enhance the structural performance. Then, Finite Element (FE) models were developed and
96 validated against the experimental results. The validated FE models were used to test the
97 performance of the optimised CFS beams. Following that a conceptual design of a module was
98 developed using the proposed optimised innovative sections through this study. The proposed
99 system would result in a lightweight MBS which has an ability to meet the identified
100 challenges. The possible challenges that limit the implementation of this work could be the
101 manufacturing of these innovative profiles and introducing staggered slotted perforations to the
102 web. However, these could be overcome by recent advanced manufacturing technologies such
103 as adjustable rollers in the forming process to produce different shapes and punching
104 techniques to introduce staggered slotted perforations.

105 **2 An overview of Modular Building System (MBS)**

106 Off-site construction involves the planning, designing, fabricating, transporting, and
107 assembling stages, with either all or the first three stages occurring in a factory specifically
108 designed for this construction method. It offers a greater degree of precision and finish in less
109 time compared to conventional construction, improves safety and resource efficiency, and can
110 enhance build quality; providing well-suited solutions to a variety of construction projects, e.g.
111 houses, schools, student accommodation. Figure 2 depicts how the individual completed
112 modules are transported and assembled on-site. Lawson et al. [21] reported that even though
113 each module needs to be transported on-site, the overall number of visits by the delivery vehicle
114 is reduced by 70%.

115

116
117
118
119
120
121
122
123
124
125
126
127
128
129
130
131
132
133
134
135
136
137
138
139
140
141
142
143
144
145
146
147
148

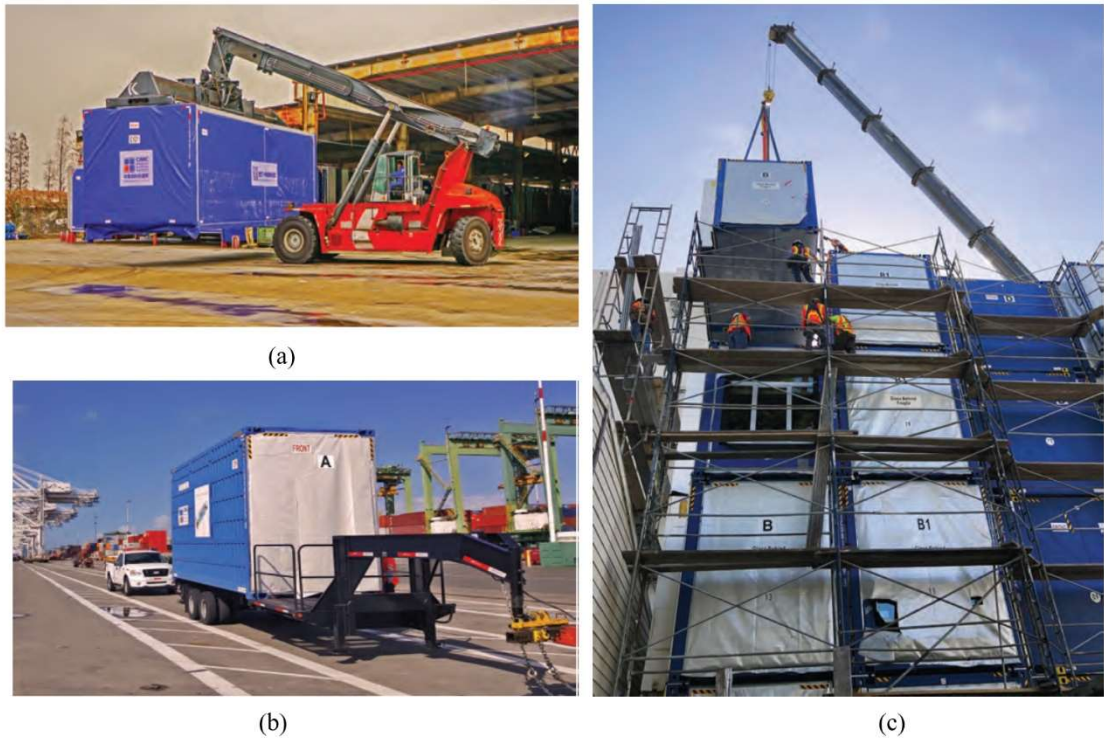

Figure 2: Modular units (a) Transporting around the factory; (b) Transporting from the factory to onsite; (c) During onsite assembly [20]

Off-site construction can be categorised in terms of the degree of finished factory works [6, 7], as follows: 1) manufacture of components, e.g. beams, columns, off-site and assembly on-site; 2) two-dimensional panelised construction off-site and assembly on-site; 3) construction of volumetric modules without fully enclosed and finished volumetric modules without interior finishes; 4) construction of volumetric modules without fully enclosed and finished volumetric modules without exterior finishes; and 5) 95% completed volumetric modules with fixtures and finishes [7]. Figure 3 illustrates the five typologies of off-site manufacture.

149

150

151

152

154

155

156

157

158

159

160

161

162

163

164

165

166

167

168

169

170

171

172

173

174

175

176

177

178

179

180

181

182

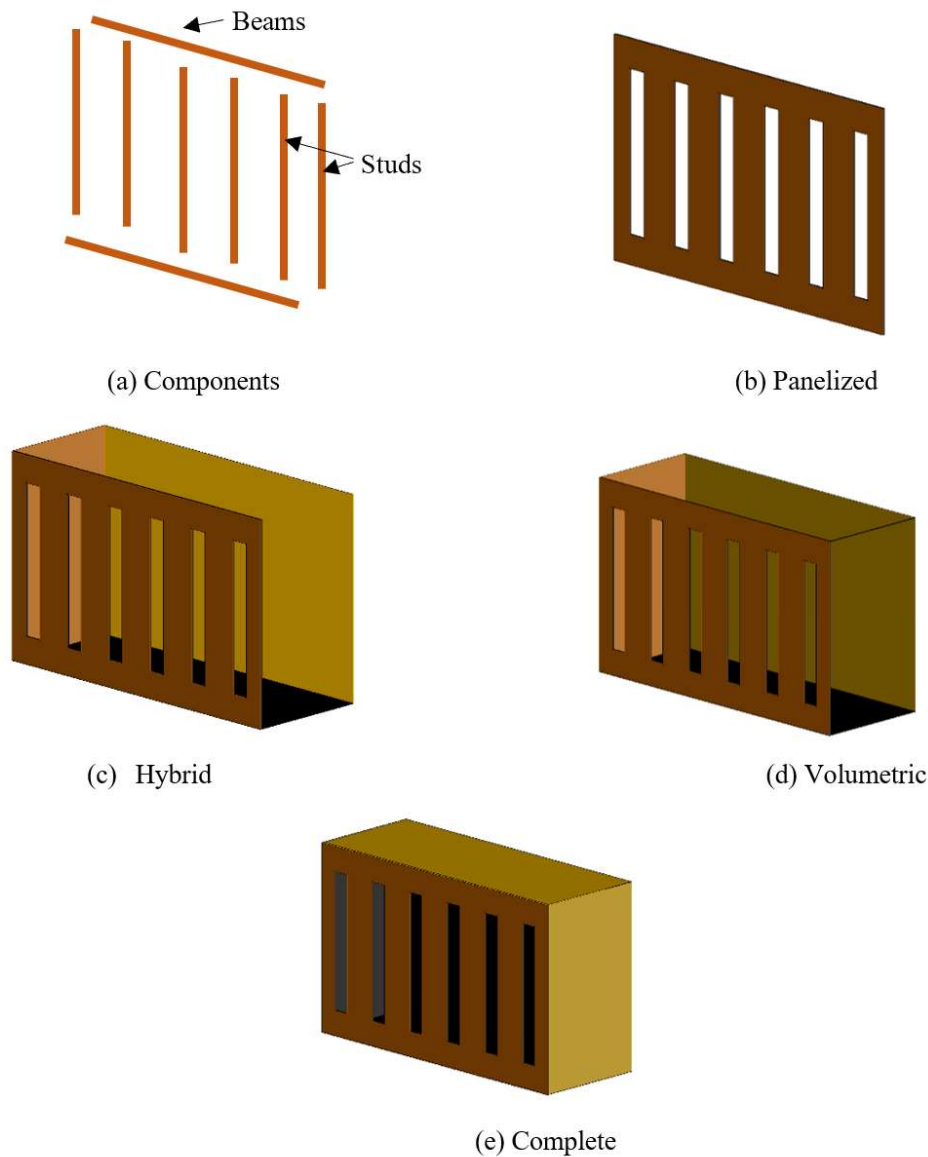

Figure 3: Typologies of off-site construction method

Volumetric modules can be further divided into two categories as load-bearing and corner supported modules in terms of structural mechanisms. Load bearing modules transfer the load through the side walls while in the corner post module, the load is transferred through corner columns from edge beams [21]. Figure 4 depicts a corner post module. In addition to that MBS is structurally strong over traditional construction. The reason for this argument is volumetric modular units are subject to the engineering process individually in an independent manner to resist the vibration during transportation and safe lifting when assembling [22].



Figure 4: Corner post-module [21]

183
184

185 MBS can be used in a variety of building constructions, e.g. education, housing, health care,
186 office, governments, dormitory, retail, and hospitality [23], and can be categorised in two
187 groups in terms of usage: temporary modular and permanent modular. The temporary modular
188 structure can be relocatable and meet short term needs, while permanent modular structures are
189 installed and fastened to a rigid foundation due to the intention of long-lasting for several years
190 (decades). Temporary modular structures can be particularly useful in post-disaster situations
191 to accommodate affected people, as it can be quickly and easily dismantled and re-assembled
192 in a new location. In general, MBS can provide more flexibility and higher efficiency compared
193 to other methods. In regards to the latter, MBS is suggested to enhance energy performance,
194 compared to other construction methods [24].

195 The energy used in buildings can be split into operational and embodied energy. Operational
196 energy, i.e. the energy used in the form of lighting, heating/air conditioning, etc. associated
197 with the use of the building, can be reduced with MBS due to its highly insulating and air-tight
198 design. Lawson and Ogden [25], suggest that with modular design an energy leakage rate of
199 less than $2\text{m}^3/\text{m}^2/\text{hr}$ can be achieved. MBS can be combined with a range of energy-efficient
200 building practices (e.g. solar panel heating systems), and utilise building materials that meet
201 the growing demand for environmentally friendly buildings. This is because of the embodied
202 energy, i.e. the energy used at the extraction, processing, manufacture, and transport of building
203 components, of buildings that are locked into their fabric as a result of the construction phase.
204 In MBS, embodied energy is mostly contained in the materials used to manufacture the external
205 building envelope. This energy can be preserved when buildings are repaired during their use,
206 retaining as such their functional purpose for longer, while they can be dismantled and

207 relocated to another site for reuse when they reach their initial end-of-use stage, extending their
208 lifespan of the building and its modules [26]. Traditionally, when buildings were no longer
209 needed, this energy was lost due to demolition and waste generation. With MBS, a large
210 amount of this energy can be saved by refurbishing the modules and retaining the components
211 with significant embodied energy. With this method, resources in the form of materials, labour,
212 money, and time can also be conserved promoting sustainability in the construction sector.

213 The off-site manufacture of modules in MBS ensures that more resource-efficient construction
214 processes occur. According to the Building Research Establishment, the UK construction
215 industry average for material wastage on site is 13%. In comparison, site waste in modular
216 construction is greatly reduced and all off-cuts are fully recycled in the factory [25]. With MBS
217 design, the construction sector can gain better control of their resource efficiency, from
218 production through to use and end-of-life management. Cost reductions both in project
219 construction and maintenance can be achieved over the lifetime of the building, whilst
220 providing a fast completion, on budget and to the required quality standard, reducing the risks
221 for the client and final end-user [1]. Moreover, there are fewer vehicle movements to site, and
222 disruption and noise levels can be reduced by 30-50% [21], compared to traditional building
223 construction methods.

224 In regards to MBS using prefabricated steel modules, an Australian case study [27] showed
225 that material consumption can be reduced up to 78% by mass compared to the use of concrete.
226 Although prefabricated steel modules are associated with a higher embodied energy (~50%)
227 compared to concrete modules, they present a higher potential for reuse. The study concluded
228 that the reuse of prefabricated steel modules can save around 81% of embodied energy and
229 51% of materials by mass. This highlights the MBS has the potential to contribute significantly
230 towards improving the sustainability of the construction industry.

231 **3 Case studies on modular buildings**

232 There are few mid-rise and high-rise modular buildings that are, or are in the process of being,
233 completed around the world. Figure 5 shows the modular construction around the world in
234 terms of percentage. Case studies on modular buildings generate useful information and
235 evidence on the performance and advantages of MBS. Moreover, variety in the case studies
236 exploring the use of MBS is necessary for developing design specifications and
237 recommendations for modular structures at different scales and spatial context [1]. This section
238 covers brief detail on case studies of popular modular buildings in developed countries.

239
240
241
242
243
244
245
246
247
248
249
250
251
252
253
254
255
256
257
258
259
260
261
262
263
264
265
266
267
268

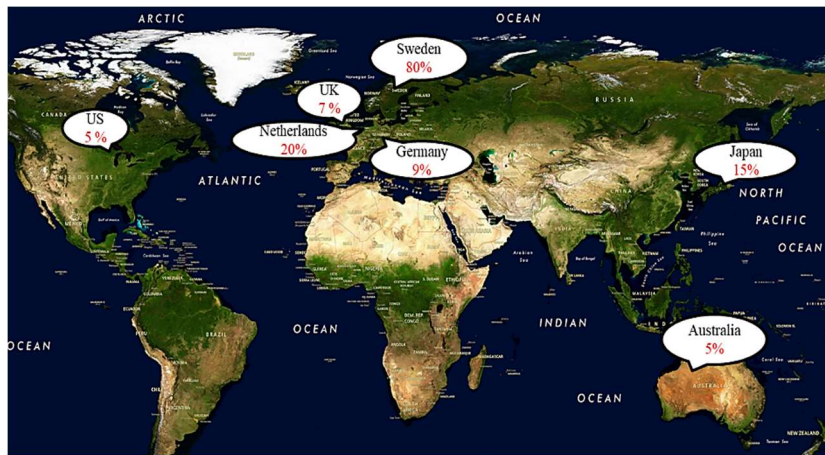

Figure 5: Modular building construction around the world

3.1 United Kingdom

Modular construction is expanding rapidly in the UK, perceived as a way to respond to three main challenges: housing crisis, skilled labour shortage, and sustainability [28]. To date, several modular buildings are being constructed and only a few of them are completed. The George Street, Croydon Towers will mark the position as the world's tallest modular building after the completion. The building is a combination of two skyscrapers, which has been forward-funded by Greystar and Henderson Park and will reach 44 and 38 storeys, respectively. The major intention of the building is to provide about 546 high-quality homes for rent, in addition, it will be utilized with winter gardens, art galleries, cafes, gyms, hubs for local business, landscaped gardens and terraces. Figure 6 depicts the architectural model and the construction phase of the Croydon building. The construction time is expected to take only two years and to be completed in 2020. Noticeably, Greystar reporting that modules are produced with 80% less waste generation compared to traditional construction [29-31]. Apex House in Wembley and Victoria Hall in Wolverhampton are the other popular modular buildings in the UK.



269

270

(a) Architectural model

(b) After the completion of concrete core

271

Figure 6: George Street, Croydon modular towers in the UK [30, 31]

272

3.2 Singapore

273

Singapore's interest on MBS has led to many local modular construction projects

274

predominantly focusing on reducing the construction period and labour resources [8]. Liew et

275

al. [8] reported that Crown Plaza Hotel Extension at Changi Airport and NTU North Hill

276

Residence Hall are the leading steel modular buildings with 10 and 13 storeys, respectively.

277

The list of steel modular building projects completed in Singapore is provided in Table 1 while

278

Figure 7 shows one of the steel modular buildings listed in Table 1, i.e., the Crowne Plaza Ext

279

@ Changi Airport.

280

281

282

283

284

Table 1: List of steel modular buildings in Singapore [8]

Project Name	No. of storey	Function
Crowne Plaza Hotel Ext @ Changi Airport	10	Hotel
NTU Norh Hill Residence	13	Hostel
NTU Nanyang Crescent Hostel	11 & 13	Hostel
Nursing Homes (Woodlands)	9	Nursing home
JTC Space @ Tuas	9	Industrial
The Wisteria Mixed Development	12	Private residential
Brownstone Executive Condominium	10 & 12	Private residential
Senja Polyclinic	12	Polyclinic, nursing home

285

286

287

288

289

290

291

292

293

294



Figure 7: Crowne Plaza Hotel Ext @ Changi Airport [8]

295 3.3 Australia

296 In Australia, approximately 3-4% of the new buildings constructed annually are modular. The
297 major limitation of this slow growth of modular construction is all the prefab constructions are
298 expected to follow the commercial and confidential clauses [1]. However, this 3-4% of present
299 modular construction is expected to be increased to 5-10% by 2030 [9]. Melbourne is the home
300 of the tallest prefabricated building in Australia, the La Trobe Tower (see Figure 8(a)). It is a
301 44 storey modular building project completed in 2016. Another example is the Little Hero low-
302 rise apartment in Melbourne (see Figure 8(b)). It was constructed with 58 single-storey
303 apartment modules and 5 double-story apartment modules. This eight-story building was
304 assembled in 8 days. Steel and concrete cores were used to withstand lateral loading [32].

305

306

307

308

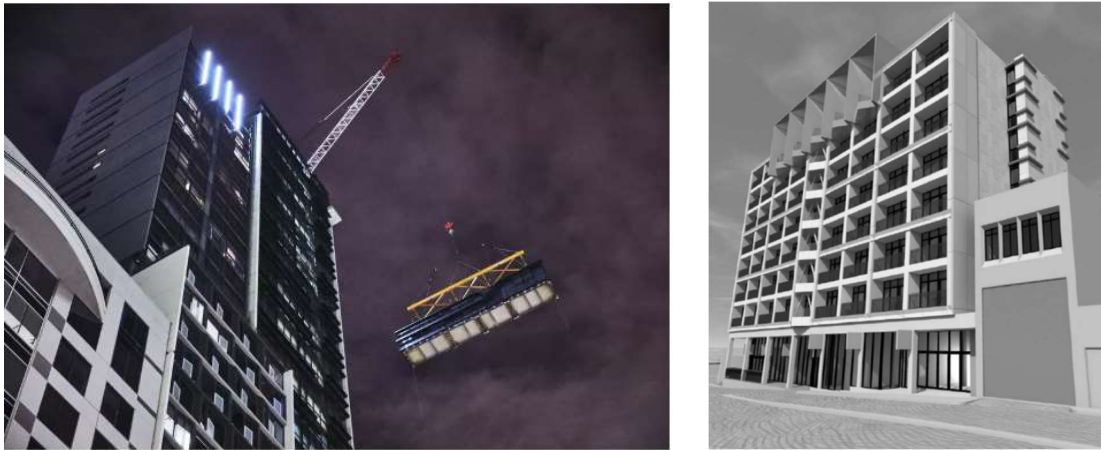

(a) La Trobe tower

(b) Little Hero building

Figure 8: Prefabricated modular buildings in Australia [32, 33]

314
315
316

317 3.4 China

318 After the establishment of the Broad Sustainable Building (BSB) in 2008, China experienced
319 some admirable achievement in producing modular building skyscrapers within a shorter
320 period. The construction technology of BSB is based on the 7 principles of sustainable
321 development which include ensuring less amount of wastage generation, improved energy
322 consumption efficiency, and producing seismic resistance buildings [2]. One pioneering
323 achievement of this company is the construction of the Sky City. Figure 9 shows the building
324 model of the Sky City, Changsa. This building has admirable characteristics with 838 m in
325 vertical height and comprised of 202 floors. About 17% of the building area is utilized with
326 commercial and spare time activity regions including offices, a hotel, 5 schools, a hospital,
327 stores, restaurants, helipads, and basketball and tennis courts. The rest 83% is for a residential
328 area. The noteworthy fact is that the estimated project duration is just 90 days and 95% of
329 manufacturing work will be performed off-site [2,4].

330
331
332
333
334
335



336

337

Figure 9: Sky City modular building in China [2]

338 3.5 Sweden

339 Sweden is the leading country in the construction of prefabricated housing. More than 80% of
340 the housing industry market is prefabricated buildings while in other developed countries
341 including the UK, US and Australia prefabrication is less than 5% [1]. In Sweden, timber
342 elements are mostly used in prefabricated modules. One of the typical prefabricated buildings
343 in Sweden is shown in Figure 10. Prefabricated modules were used to develop an economical
344 construction process. 196 prefabricated units were arranged to form 35 m high building and
345 each module is square in shape with 3.6 m width. It has been developed to ensure well suited
346 urban living for inhabitants [34].

347

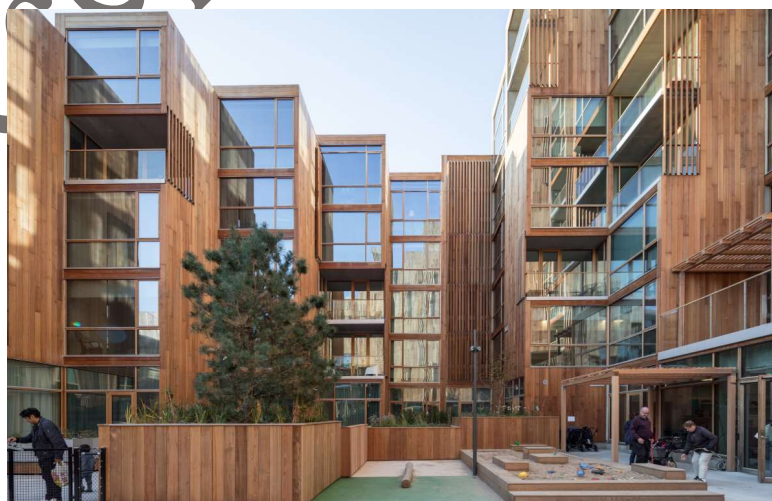

348

349

Figure 10: Prefabricated modular building in Sweden [34]

4 Structural performance of optimised innovative sections

This paper also attempts to highlight the enhanced structural performance of the innovative light gauge steel sections and to increase the application into light gauge steel construction, especially in modular buildings. In this comparative study, three optimised sections are considered. It has been noticed that still, the light gauge steel construction industry highly employing Lipped Channel Sections (LCB). A commercially available LCB section is also considered as a benchmark section in order to compare the structural performance of the novel sections. In addition, the available LCB section is also optimised. Figure 11 depicts the selected benchmark section while Table 2 narrates the selected novel sections that are to be optimised to employ into MBS.

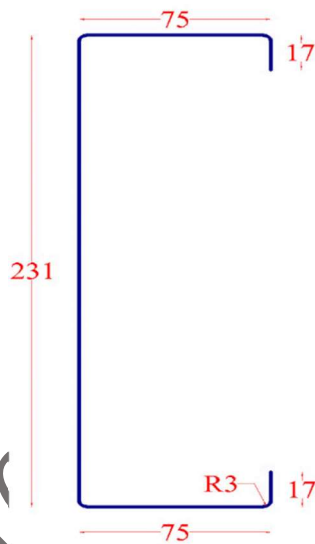

Figure 11: Benchmark LCB section

Table 2: Selected innovative sections for optimisation [17]

LCB	Folded-Flange	Super-Sigma

373

374 4.1 Overview of the optimisation process

375 The optimisation process leads to the enhanced structural performance of the selected
 376 innovative prototypes. The optimisation process was performed with PSO algorithm, which is
 377 developed based on the natural swarming behaviour of birds flock and schools of fish [35].
 378 Moreover, PSO has some similarities and dissimilarities over GA which is previously used for
 379 structural optimisations. One of the major advantages of PSO over GA is the practical
 380 manufacturing and theoretical constraints can be incorporated easily [15]. The extensive detail
 381 on optimising structural beam members using PSO can be found elsewhere [15-17]. Initially,
 382 for the selected innovative sections, section moment capacity equations were developed based
 383 on the provisions provided in Eurocode (EN-1993-1-3 [36] and EN-1993-1-5 [37]).
 384 Subsequently, the developed section moment capacity equations were combined with the PSO
 385 algorithm which was generated through MATLAB [38]. More importantly, the theoretical
 386 constraints, that are mentioned in EN-1993-1-3 [36] and practical and manufacturing
 387 constraints reported in [16], were set as the lower and upper bounds of the varying parameters
 388 (see Table 2). During the optimisation process, the amount of material was maintained as same
 389 for the benchmark section (Coil length = 415 mm and Thickness = 1.5 mm). Further, the similar
 390 mechanical properties were also used for the benchmark and selected innovative sections
 391 (Modulus of elasticity = 210 000 MPa, Yield strength = 450 MPa and Poisson's ratio = 0.3).
 392 The optimised dimensions for the selected innovative sections and the optimised section
 393 moment capacities are given in Table 3. The optimised section moment capacities were then
 394 verified with the advanced FE analysis.

395

396 Table 3: Optimised capacities of the selected sections with dimensions [17]

Prototypes	h (mm)	b (mm)	c (mm)	d (mm)	w ₁ (mm)	w ₂ (mm)	w ₃ (mm)	δ ₁ (°)	δ ₂ (°)	Capacity (kNm)
LCB_benchmark*	231	75	17	-	-	-	-	-	-	10.30
LCB_optimised	269	50	23	-	-	-	-	-	-	13.38
Folded-Flange	185	48	50	17	-	-	-	105	95	16.12
Super-Sigma		50	17.5	-	41	30	139	34	-	17.43

397 *Dimensions given for LCB benchmark is not the optimised dimensions

398 4.2 Analysis overview

399 The optimised novel sections were analysed with an advanced FE method in order to
 400 investigate the flexural behaviour extensively. A general-purpose software, ABAQUS version
 401 2017 [39], was used for this investigation. FE models of four selected prototypes were

402 modelled as four-point loading set-up with simply supported boundary conditions. This four-
403 point loading arrangement ensures pure bending failure in the mid-span with the absence of
404 shear stress. A detailed description of the FE model development including element type,
405 material properties, mesh refinement, load and boundary conditions, geometric imperfections,
406 and analysis method are provided in Table 4.

407 Table 4: FE Model description and analysis method

Model characteristics	Brief description
Model set-up	Four-point loading with middle span and two adjacent spans.
Boundary conditions	General simply supported boundary conditions
Loading method	Displacement control loading with smooth step amplitude at two middle supports, displacement was set to increase from 0 to 70 mm.
Residual stress	Residual stress is not incorporated into the model as Keerthan and Mahendran [40] reported that the effect of residual stress in CFS beams is less than 1%.
Material model	CFS was assumed as having perfect plasticity behaviour. The research findings from Keerthan and Mahendran [40] showed that adopting strain hardening behaviour only improve the capacity by 1%. Therefore, strain hardening behaviour was not considered in FE analyses.
Element type	Beam model was developed with S4R shell element available in ABAQUS. Shell element has the ability of simulating non-linear behaviour during the ultimate bending behaviour analyses. S4R shell element has the reduced integrations, thus less time consuming for the analysis than S4 shell elements in ABAQUS [41].
Mesh refinement	Web and flange segments were provided with a mesh refinement of 5 mm × 5 mm while the folded edges (corners) were provided with finer mesh refinement of 1 mm × 5 mm due to the critical behaviour of bends on the capacity. For slotted channels, the web was provided with a mesh refinement of 1.5 mm × 5 mm.
Geometric imperfections	The magnitude of the imperfection was considered as a function of plate segment width, d_1 . The magnitude of $0.006d_1$ was assigned to all FE models via bifurcation buckling analysis [42]. The shape of the imperfection was introduced via *IMPERFECTION option available in ABAQUS.
Web side plates	Web side plates were simulated with coupling constrain and with a reference point (shear centre). The web side plate area in the model was coupled to the shear centre and loading and support boundary conditions were applied to that point [43].
Analysis method	Linear buckling analysis – First elastic buckling mode, which is commonly a critical mode, was used to incorporate the imperfection shape and magnitude
	Non-linear static analysis – The effect of material yielding and large deformations were taken into account
Convergence criteria	Convergence difficulty was overcome by specifying artificial damping factors. The default artificial damping factor defined in ABAQUS was employed.

408

409

410 4.3 Validation

411 The FE models were developed based on the validation of experimental data in order to ensure
412 the FE model characteristics are well suited to predict the ultimate bending capacity accurately.
413 With the mentioned model characteristics FE models of LCBs and Sigma sections were
414 developed, subsequently, the failure modes and ultimate section moment capacities were
415 verified with the experimental results reported by Pham and Hancock[44] and Wang and
416 Young [43], respectively. It is noteworthy to mention that for both LCB and Sigma sections
417 validation process, Web Side Plates (WSPs) were simulated with coupling constraint which
418 restrains the all the translation and rotation of the WSP surface in the model to a single point
419 (shear center) as used in [43]. Table 5 provides the validation results of the LCB and Sigma
420 sections with experimental data. Overall, the mean value of the test to FE analysis is 0.96 while
421 the corresponding coefficient of variation (COV) is 0.059. Figure 12 shows the load-
422 displacement behaviour and failure mode comparison of FE results over experiment results of
423 the C20015 LCB section. Based on these comparisons, it can be concluded that FE analysis
424 reveals a satisfactory agreement with experimental results. Therefore, considered FE
425 characteristics are able to predict the ultimate bending capacity accurately of the optimised
426 novel sections.

427
428

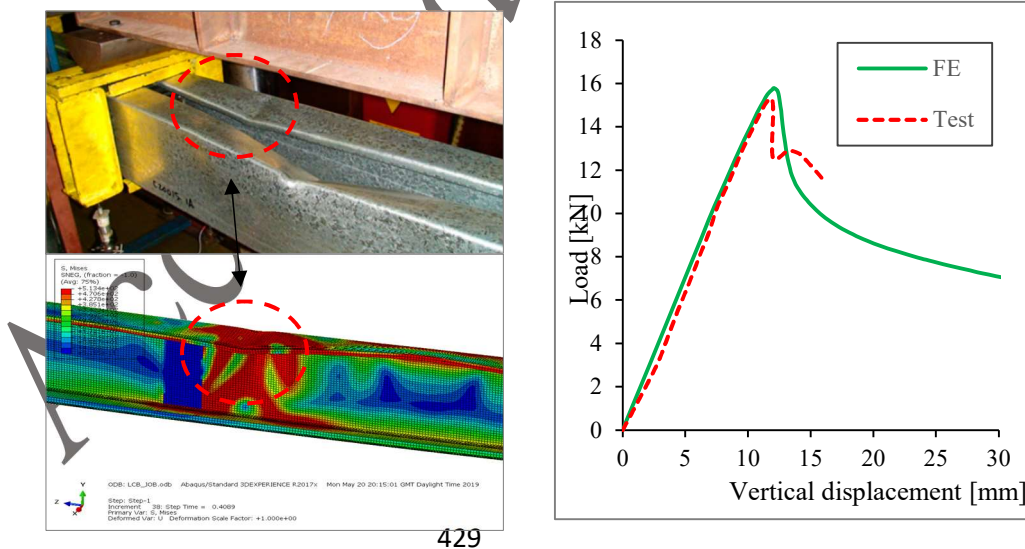

430 (a) Failure mode comparison

(b) Load- vertical displacement comparison

431 Figure 12: Comparison of failure mode and load- vertical displacement behaviour for C20015 [45] with FE
432 results

433
434
435

436
437
438
439

Table 5: Validation of the bending models with experimental data

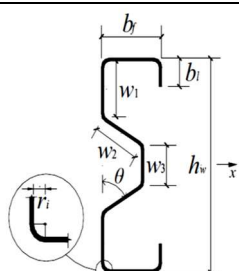
Specimen	M_{Test} (kNm)	M_{FEA} (kNm)	M_{Test}/M_{FEA}	
Pham and Hancock [44] – LCB sections				
	Mw C15015	9.47	9.62	0.98
	Mw C15019	12.90	14.72	0.88
	Mw C15024	17.96	17.05	1.05
	Mw C20015	12.20	12.69	0.96
	Mw C20024	27.88	27.53	1.01
Wang and Young [43] – Sigma sections				
	C-0.48-B4	1.03	1.07	0.96
	C-1.0-B4	2.99	3.31	0.90
Min				0.88
Max				1.05
Mean				0.96
COV				0.059

440 4.4 Flexural performance of optimised sections

441 The selected innovative sections were modelled and analysed through FE analysis based on the
 442 validation process. Similar model characteristics were adopted to investigate the flexural
 443 behaviour of the innovative sections. Figure 13 shows the developed FE model of the optimised
 444 sigma (Super-Sigma) section. This figure illustrates the provided mesh refinement and the
 445 details of the simply supported boundary conditions. Other considered innovative sections were
 446 also provided with similar boundary conditions. Figure 14 shows the flexural failure modes
 447 observed from the FE analysis and as expected the failure occurred within the pure bending
 448 zone (middle span). The load -vertical displacement (displacement of the midpoint of the span)
 449 relationships of the considered sections are plotted in Figure 15. Further, the stage by stage
 450 failure mode for the Super-Sigma section is narrated in Figure 16. The section moment

451 capacities obtained for the considered innovative sections through FE analysis were then
452 compared with the section moment capacity predictions obtained from the EN 1993-1-3 [36].
453 Table 6 provides the comparison of the section moment capacity predictions from FE analysis
454 and EN 1993-1-3 [36]. The result gives a mean value of 1.00 along with a COV value of 0.022.
455 Thus, FE and EN 1993-1-3 [36] prediction show a good agreement on predicting section
456 moment capacities. Moreover, Table 6 also provides the bending capacity enhancement of the
457 optimised innovative CFS sections in terms of percentage by taking the selected commercially
458 available conventional LCB (see Figure 11) as a benchmark.

459
460
461

462 Table 6: Comparison of section moment capacity predictions obtained from EN 1993-1-3 and FE analysis [17]

Sections	M_{EC3} (kNm)	M_{EC3} (%)	M_{FE} (kNm)	M_{FE} (%)	M_{EC3}/M_{FE}
LCB_benchmark	10.30	100 %	10.41	100 %	0.99
LCB_optimised	13.38	130 %	13.28	128 %	1.01
Folded-Flange	16.12	156 %	16.60	159 %	0.97
Super-Sigma	17.43	169 %	16.90	162 %	1.03
Min					0.97
Max					1.03
Mean					1.00
COV					0.022

463
464
465
466
467
468
469
470
471
472
473
474
475
476
477

478
479
480
481
482
483
484
485
486
487
488
489
490
491
492
493
494
495
496
497
498
499
500
501
502
503
504
505
506
507
508
509
510
511

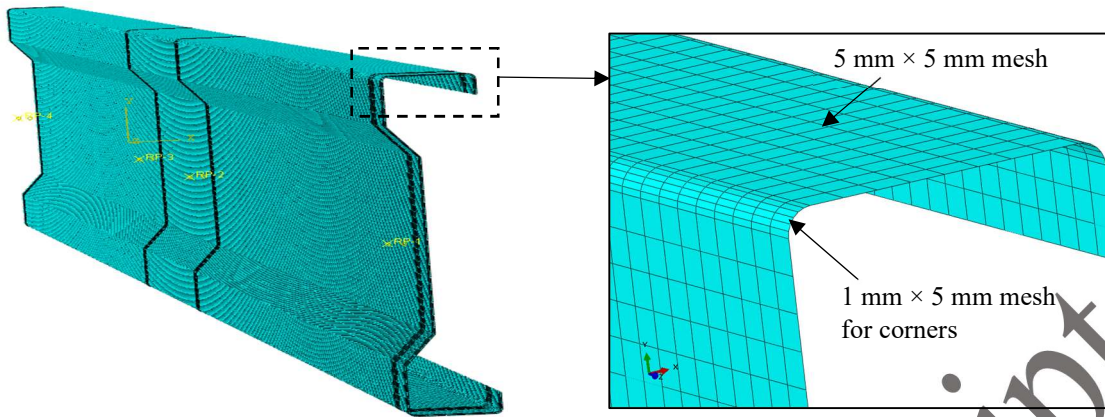

(a) FE discretization

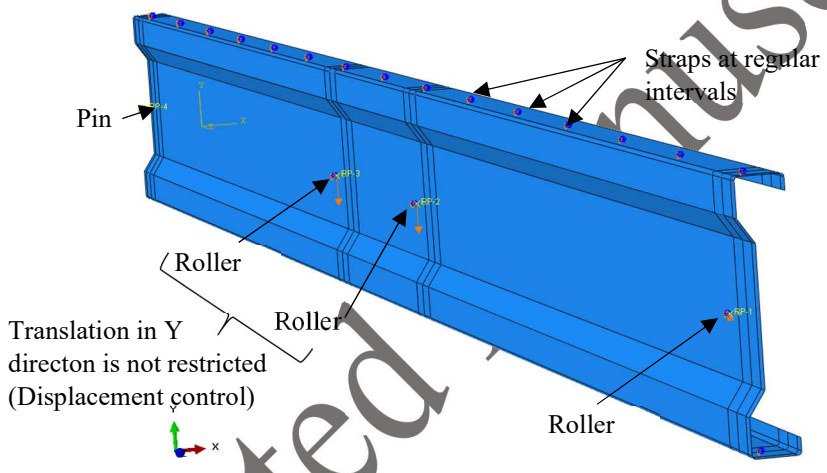

(b) Boundary conditions

Figure 13. FE model development of Super-Sigma section

512
 513
 514

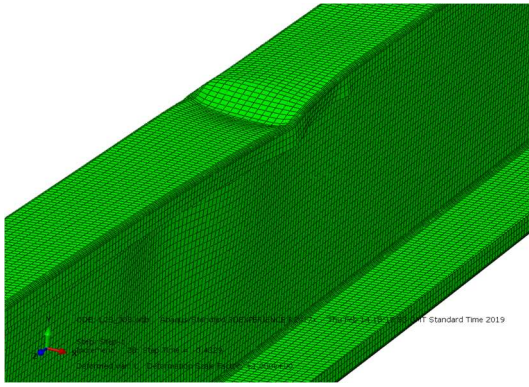

(a) LCB benchmark

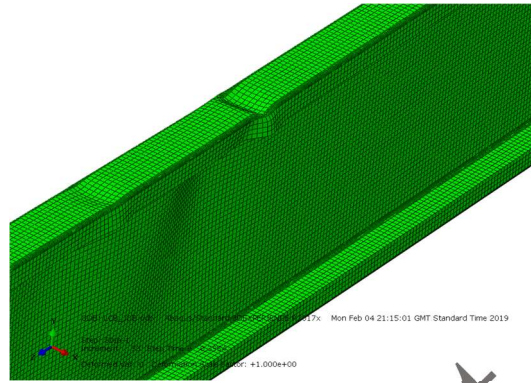

(b) LCB optimised

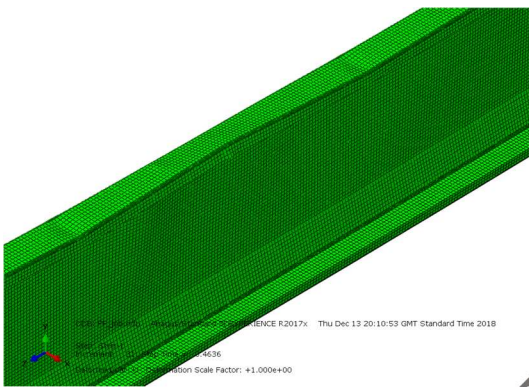

(b) Folded-Flange

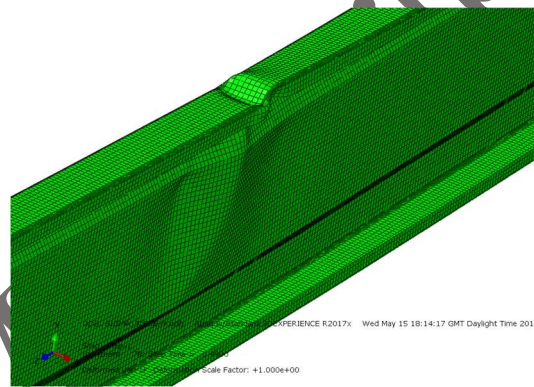

(b) Super-Sigma

516
 517
 518

Figure 14: Flexural failure modes of considered innovative sections

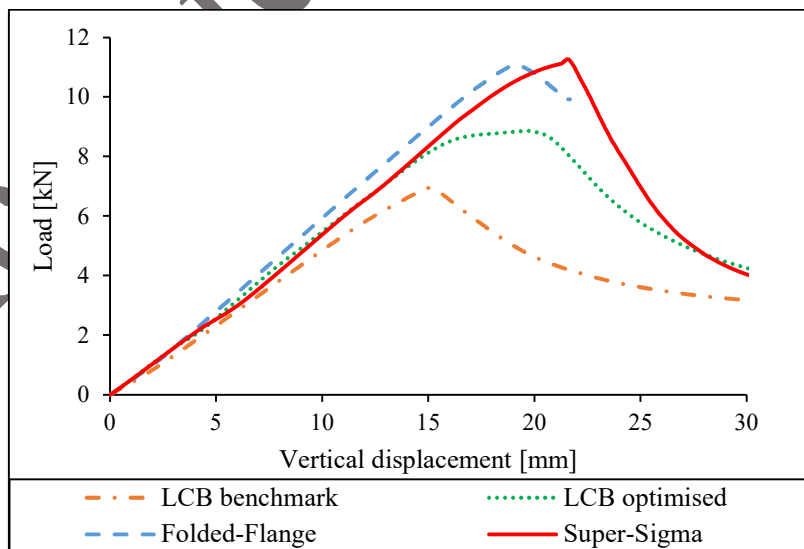

519
 520

Figure 15: Load – vertical displacement behaviour of innovative sections

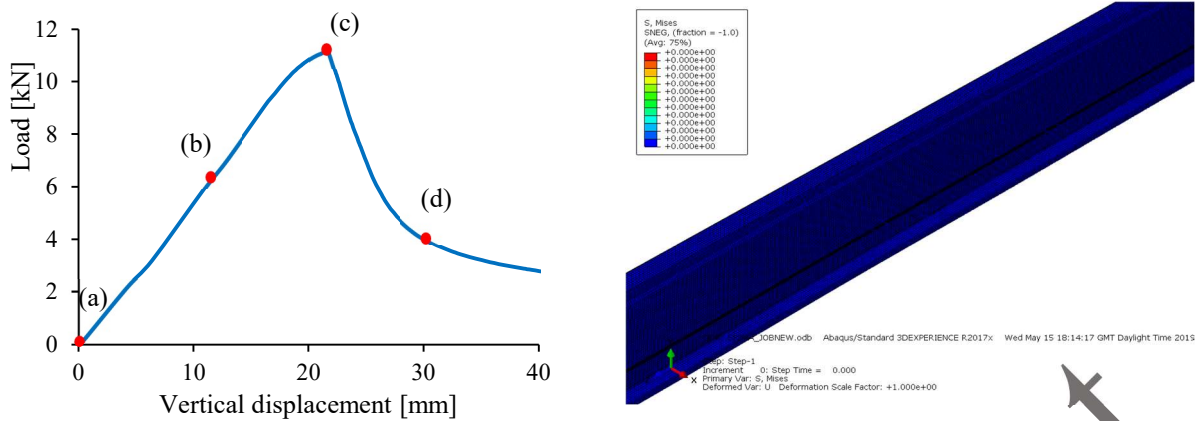

521
522

(a) Initial stage

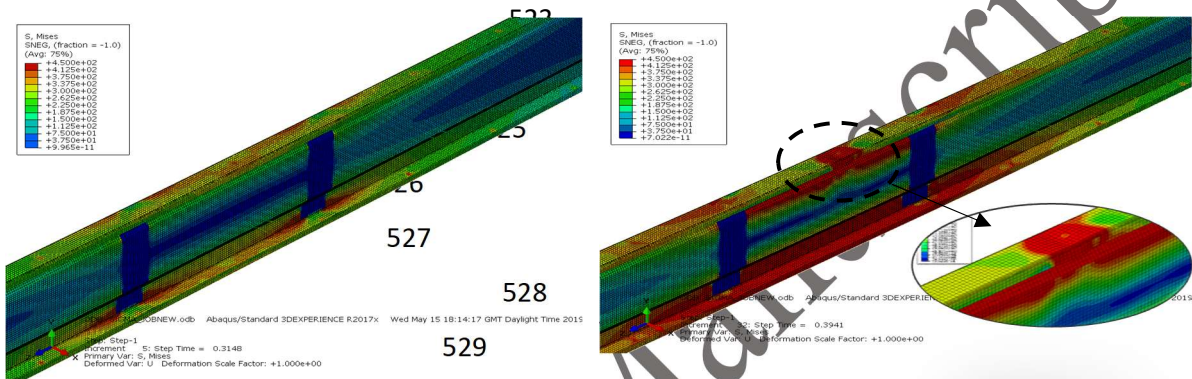

(b) Prior to failure

(c) Ultimate stage

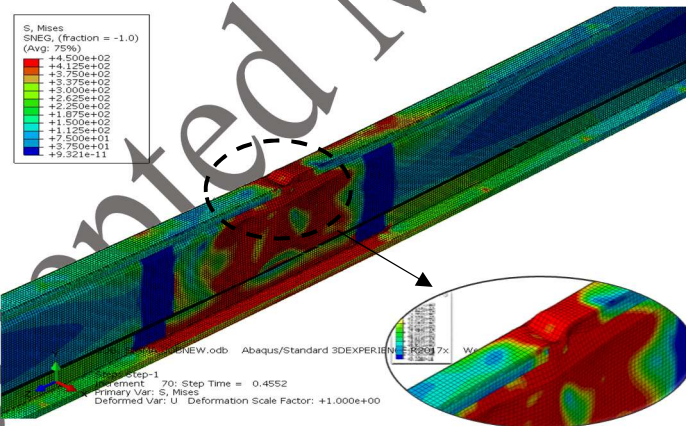

(d) Post failure

Figure 16: Failure modes of Super-Sigma section at different stages

530
531
532
533
534
535
536
537
538
539
540
541
542
543
544
545
546
547

The results reveal that Super-Sigma section has the ability to withstand about 65% higher bending actions compared to the benchmark section. When compared to other considered sections (lipped channel section and folded-flange sections) with the same amount of material, the super sigma section has the highest bending capacity. Moreover, sigma sections naturally have a closer shear centre to the web due to the stiffened web. Therefore, this adds more value to the Super-Sigma sections because the closer shear centre to the web minimises the torsional failure due to eccentric loading. In common practice, substantial lateral restraint methods are

548 being used to overcome this torsional issue. Therefore, employing Super-Sigma section as
549 flexural members in floor and roof panels would result in a substantially improved structural
550 performance along with the lightweight structural system.

551 4.5 Flexural performance of slotted sections

552 Incorporating slotted perforations to CFS channels will enhance the thermal performance as it
553 increases the thermal transmittance path (see Figure 17). However, these slotted perforations
554 can reduce the load carrying capacity of the CFS channels. Therefore, slotted perforations were
555 provided to webs of the optimised sections while the reductions of bending capacity were also
556 evaluated through FE analysis. The dimension of the slots and its configuration in the web is
557 depicted in Figure 18. Model characteristics provided in Table 4 were used to construct and
558 analyse the slotted channels. Figure 19 illustrates the failure mode obtained for the optimised
559 sections with the incorporation of slots while Figure 20 shows the reduction of bending
560 capacity due to the incorporation of slots. It can be noticed that for all the sections less than
561 10% of the bending capacity is reduced and these reductions are well ahead of the bending
562 capacity of the benchmark section. To elaborate, 18%, 55%, and 57% of flexural capacity
563 enhancements were achieved for optimised LCB, folded flange, and super-sigma sections,
564 respectively even with the inclusion of slotted perforations.



565
566
567
568
569
570
571 (a) Application of slotted perforated CFS channels

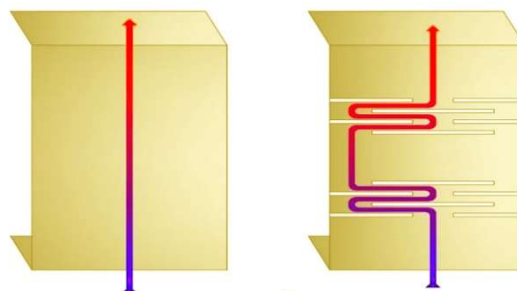

572
573
574
575
576
577
578 (b) Heat transfer path of solid and slotted perforated channels

579 Figure 17: Slotted perforated CFS channels

580
581
582
583
584
585
586
587
588
589
590
591

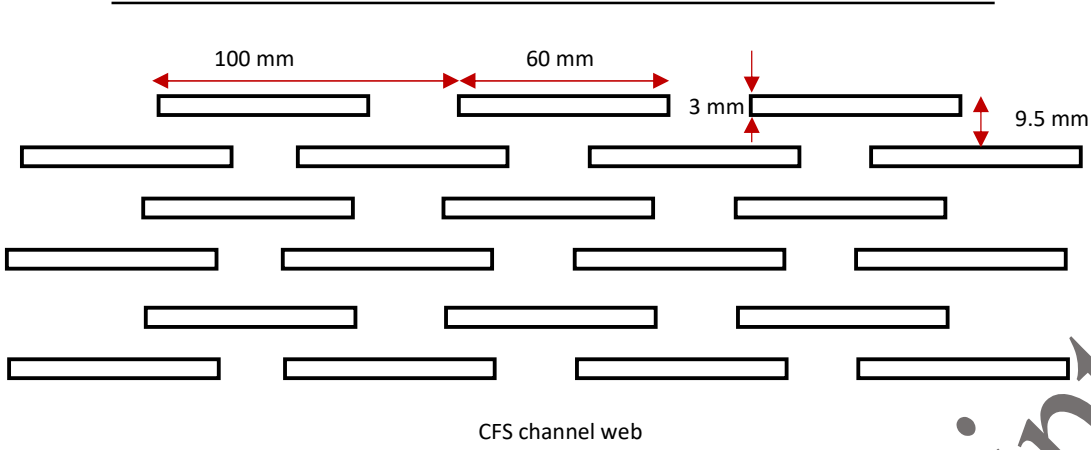

Figure 18: Slots configuration and dimensions

592
593
594
595
596
597
598
599
600
601
602
603
604

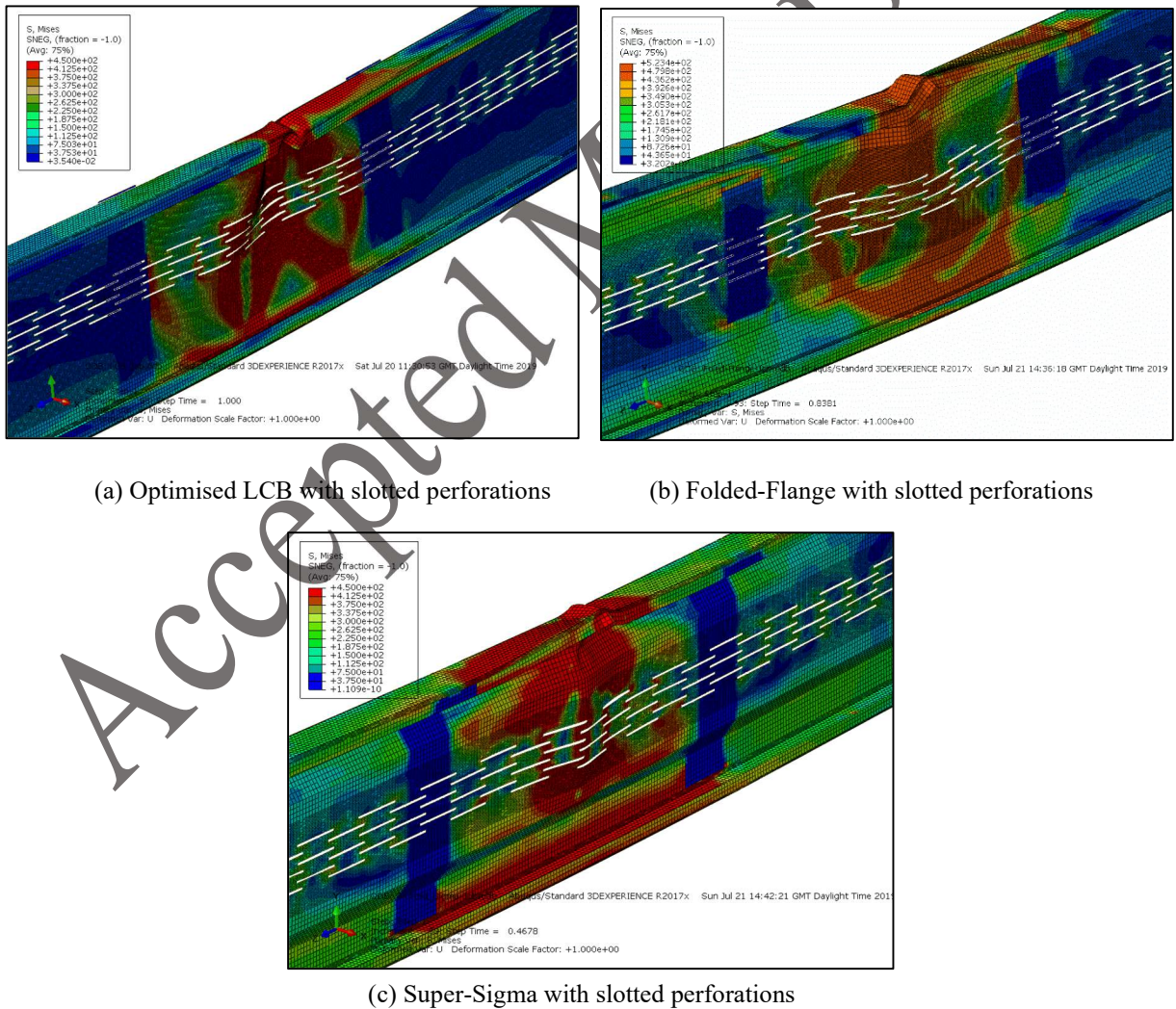
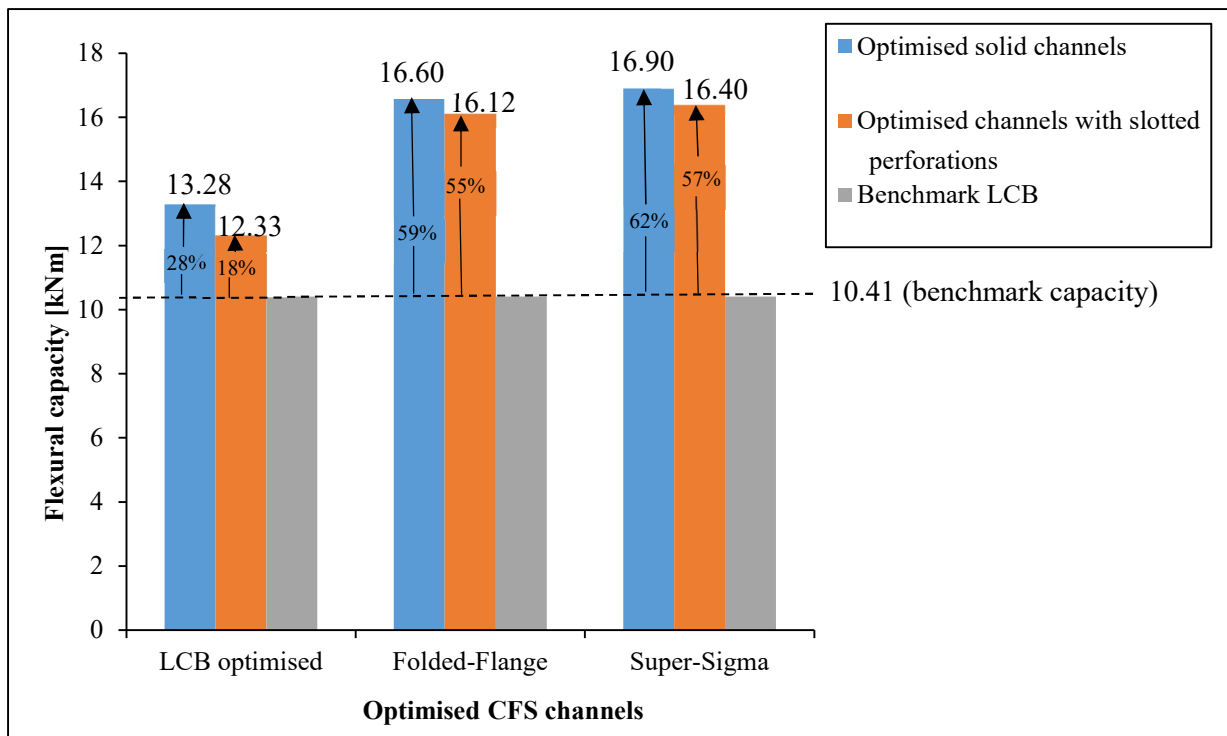

Figure 19: Failure modes obtained for optimised CFS sections with slotted perforations



605

606

Figure 20: Bending capacities of optimised channels with slotted perforations

607

608 Therefore, including slotted perforations to the optimised sections would results in enhanced
609 bending capacity along with amplified thermal performance. These findings are significant
610 enough to address the challenges related to modular buildings. The detail on how these
611 optimised CFS channels with slotted perforations can address the MBS challenges are
612 described in following sections.

613 5 MBS challenges and solutions

614 5.1 Structural efficiency

615 MBS can be identified as a complex structural system despite its easy installation process. The
616 load transferring mechanism in MBS cannot be easily understood [1] as these systems use non-
617 conventional connections which can be classified as inter-module connection, intra-module
618 connection, and module to foundation connection. In addition, Navaratnam et al. [1] state that
619 there is limited research to study the structural response of MBS. Therefore, components with
620 enhanced load carrying capacity are recommended to overcome the complexity in load
621 transferring mechanism and to ensure a safe design in extreme load scenarios. The optimised

622 sections are suitable to meet this challenge as those have up to 65% of flexural capacity
623 enhancement.

624 5.2 Fire resistance and energy performance

625 Nowadays more attention is paid towards fire safety of building after the detrimental fire
626 accident occurred at Grenfell Tower, London, UK in 2017. Recent research studies [1, 8, 10]
627 highlighted that there are limited studies related to fire performance of MBS. The fire safety of
628 modular buildings can be divided into two categories: local fire safety and global fire safety.
629 The first one defines the fire resistance of individual module and the latter one is about
630 preventing the fire spread from module to module [8]. Webs in CFS in beams are often exposed
631 to fire and temperature rise in webs occurs at a higher rate than flanges, especially when flanges
632 are attached to the floor toppings. This rapid temperature rise can be controlled by providing
633 staggered slotted perforations in CFS beam web and that will result in improved fire
634 performance [46]. Providing slotted perforations to the optimised CFS sections as proposed
635 through this study enhances the response to changes in temperature that could ultimately
636 improve the energy efficiency of the MBS.

637 5.3 Lightweight materials

638 Lacey et al. [10] and Liew et al. [8] highlighted the need for a lightweight structural system
639 with high-performance materials for MBS. CFS modules are preferred over concrete modules
640 as steel modules are 20-35% lighter than concrete modules. MBS entirely employed with light
641 gauge steel members can reduce the construction time compared to concrete modules, and
642 promote great flexibility. Concrete joints can only be connected with in-situ grouting, while
643 steel connections can be simply joined together with bolts [8]. Moreover, CFS components can
644 be replaced, easily reassembled, and have no long-term issues such as durability, creep, and
645 shrinkage.

646 Table 7 shows the entire weight distribution of a steel modular unit. About 40% of a modular
647 unit's weight is attributed to the partition wall panels, while floor slab panels claim about 30%
648 [8]. The optimised CFS sections always lead to material saving compare to conventional CFS
649 sections. Replacing the floor slab with optimised light gauge steel floor panel employed with
650 folded-flange and super-sigma sections will substantially reduce the weight of the modular
651 unit.

652

653

654
655

Table 7: Weight distribution of a steel modular unit [8]

Module components	Weight distribution
Partition	40%
Floor slab	30%
Finishes	14%
Ceiling deck	7%
Column	6%
Beam	3%

656

657 5.4 Access requirements

658 Ferdous et al. [9] and Lacey et al. [10] reported that workers face accessibility limitations to
659 install inter-module connections. This may be due to the complex arrangement of the MBS
660 elements. The optimised light gauge steel members proposed in this study have enhanced load-
661 bearing capacities. Those members can carry the loads from a large area, therefore, it results in
662 the enhanced spacing between the members. For example, a spacing of 400 mm is generally
663 provided between conventional floor joist members and this system could be replaced with
664 folded-flange or super-sigma floor joist with 600 mm spacing. This enhanced spacing between
665 the members and that would address the problem of the limited access in modular buildings for
666 the workers to access the inter-module connections and even during repairing/replacing
667 structural members.

668 5.5 Transportation limitations

669 Modular construction involves a phase of transporting modules from off-site to on-sites via
670 trucks. Generally, the weight of a steel modular unit lies around 20 t [8]. It should be noted that
671 certain roads and bridges have weight limitations and there are some weak bridges with weight
672 limits below 20 t. In this situation, an alternative route is required to transport the modules to
673 on-site for assembly and that may cause additional expenses as well as delay in the project
674 timeline. This challenge can be meet through employing optimised CFS sections proposed in
675 this study into MBS as it results in lightweight modules.

676 5.6 Lifting capacity of tower crane

677 The lifting capacity of the tower crane (generally less than 20 t) has been identified as one of
678 the major on-site issues in MBS through the research study performed by Liew et al. [8].

679 Further, that study claims 60% cost increment for tower crane when lifting weight is beyond
680 20 t. The use of optimised CFS sections in MBS can significantly solve this issue as it ensures
681 a lightweight module as explained in section 5.3.

682 Therefore, utilizing MBS with optimised Super-Sigma sections will be able to meet the identified
683 challenges of the need for improved structural, fire and energy performances, lightweight
684 structure, access difficulties during the repair, transportation difficulties and weight limits of
685 the tower cranes to lift a module. Moreover, these optimised Super-Sigma sections can be
686 employed as purlins and rafters in light gauge steel constructions.

687 **6 Design of MBS using optimised sections**

688 6.1 A brief summary of design of light steel modules

689 This section summarises the structural design procedures for light steel modules given by
690 Lawson et al. [47]. Modules are generally designed according to the standard specifications of
691 a particular project. The structural design of light gauge steel modules in accordance with UK
692 National annex and Eurocodes pays attention to several key factors. Those are load and load
693 combinations, types of the modules to be used, the connection between modules, stability
694 methods (bracing, diaphragm action, moment-resisting connections), construction tolerances,
695 individual design of structural elements, and structural integrity. Table 8 presents the design
696 checks to be ensured for light gauge steel modules. These design guidelines approximate the
697 design of MBS even though there are no specific standards or recommendations for modular
698 building design.

699 6.2 Conceptual design of MBS using optimised CFS sections

700 This study has identified that the Super-Sigma sections have enhanced flexural performance
701 than conventional sections. Therefore, employing Super-Sigma sections into MBS as flexural
702 members will result in a more economical and efficient design solution. Lawson [48] illustrated
703 the arrangements of the structural elements in a corner post-module constructed with LCB
704 sections (see Figure 21). Since Super-Sigma sections have been identified as better
705 performance over LCB in terms of flexural capacity, proposed MBS will be designed with
706 Super-Sigma sections (ceiling and floor joists). The loads from the Super-Sigma floor and
707 ceiling joist will be transferred to longitudinal edge beams which are connected to the corner
708 posts (see Figure 22).

709
710
711

Table 8: Design checks for light gauge steel modules [47]

Checks	Equations	Notations
Permitted cumulative out of –verticality tolerance	$\delta_H = 12(n - 1)^{0.5}$	n = number of modules in the vertical assembly
Additional moment generated on the base module (due to combined effect of eccentricities of loading and installation)	$M_{add} = P_{wall}\Delta_{eff}$ $\Delta_{eff} = 3n^{1.5} \text{ for } n < 12$	P_{wall} = Compression force at the base Δ_{eff} = effective eccentricity of the vertical group of modules
Effective slenderness of wall studs	$\lambda = l_{eff}/r_{yy}$	l_{eff} = effective length of the stud r_{yy} = radius of gyration about the major axis
Buckling reduction factor for studs	$x = \frac{1}{\phi + \sqrt{\phi^2 - \bar{\lambda}^2}}$ $\bar{\lambda} = \frac{\lambda}{\pi} \sqrt{\frac{f_y}{E}}$ $\phi = 0.5[1 + \alpha(\bar{\lambda} - 0.2) + \bar{\lambda}^2]$	$\bar{\lambda}$ = slenderness ratio f_y = yield strength of the steel E = Modulus of elasticity
Compression resistance of the member	$P_c = A_{eff}x f_y$	A_{eff} = Effective area of the cross-section
Combined bending and compression	$\frac{P}{P_c} + \frac{P_e + M_w}{M_{el}} \leq 1.0$	P = Applied compression force M_w = Bending moment due to wind loading M_{el} = Elastic bending resistance
Bending of horizontal member	$M \leq M_{el}$	M = Applied bending moment
Serviceability limits	Imposed loads deflections \leq span / 450 Total load deflection \leq span / 350 but \leq 15 mm Natural frequency \geq 8 Hz for rooms \geq 10 Hz for corridors	
Natural frequency of floor	$f = \frac{18}{\sqrt{\delta_{sw}}}$	δ_{sw} = deflection due to the self-weight of the floor and an additional load of 30 kg/m ²
Combined compression and bending actions on corner posts	$\frac{P}{P_c} + \frac{P_e + M_w}{M_{by}} + \frac{P_e}{M_{bz}} \leq 1.0$	M_{by} = Buckling resistance moment in y direction M_{bz} = Buckling resistance moment in z direction e = Total eccentricity of axial load

712

713

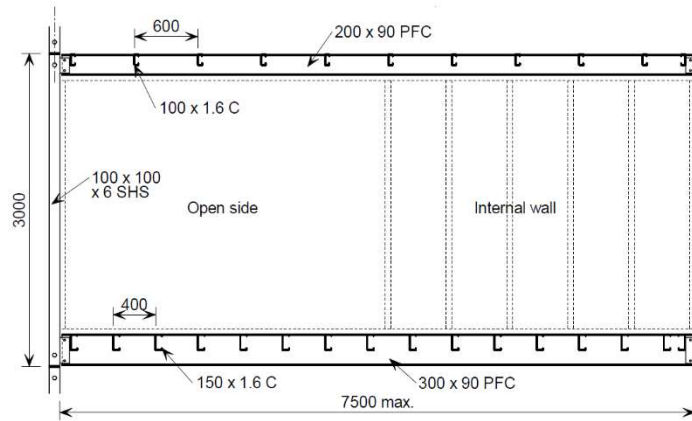

714

715

Figure 21: Common structural member arrangement of a corner post module [48]

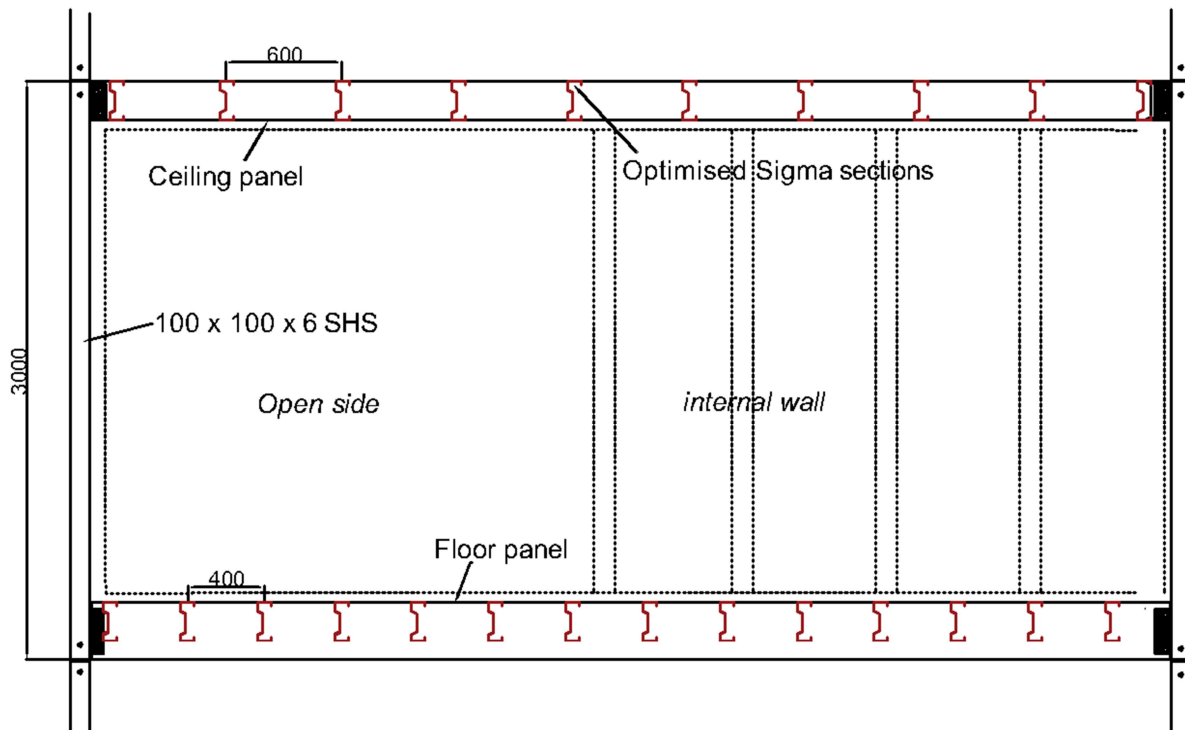

716

Figure 22: Conceptual layout of the corner post module employed with Super-Sigma sections

717

718 The proposed framework of the module is employing CFS members, such as Square Hollow
719 Section (SHS) columns and either high gauge CFS or hot rolled steel edge beams that are bolted
720 together. The stability of the building generally depends on a separate bracing system in the
721 form of X-bracing in the separating walls. For this reason, proposed fully open-ended modules
722 be not used for buildings more than three storey high. Where used, infill walls and partitions
723 within the modules are non-load bearings, except where walls connected to the columns
724 provide in-plane bracing. As recommended by Liew et al. [8], SHS column can be filled with
725 lightweight concrete to maintain the stability for medium and high rise MBS. The corner posts

726 provide the compression resistance and are typically 100 x 100 SHS members. The edge beams
727 will be connected to SHS posts by fin plates, which provide nominal bending resistance. End
728 plates and bolts to the SHS members will also be used as shown in Figure 23.
729

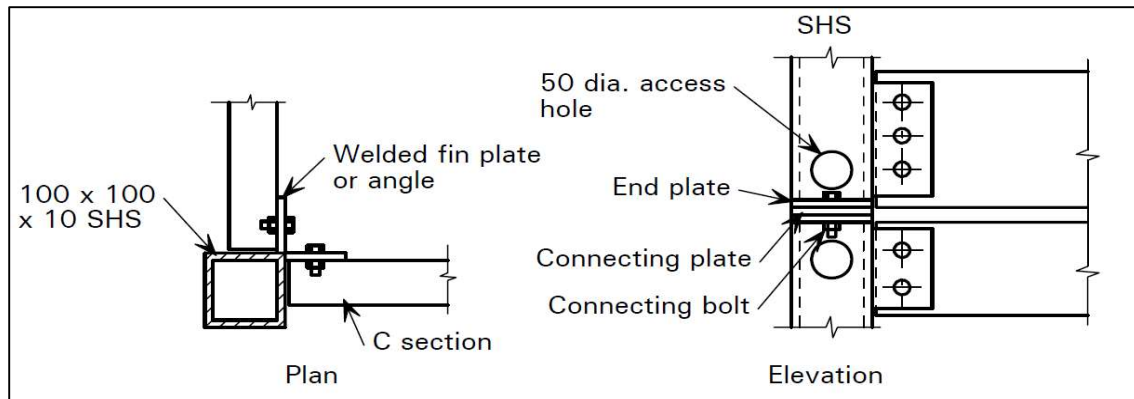

730

731

Figure 23: Corner post module connection [48]

732

733 Further research on modular building connections, structural tests and advanced finite element
734 models of modular building systems are in progress. It should be noted that the spacing between
735 floor/ceiling joists can be increased for Super-Sigma sections compared to LCB sections as
736 Super-Sigma sections can bear about 65% higher flexural capacity than the conventional LCB
737 sections.

738 7 Ongoing and Future works

739 This paper introduces the concept of employing optimised innovative CFS section into MBS
740 to enhance the structural performance and ensuring the lightweight module. In addition to the
741 newly proposed Super-Sigma and other sections, few other innovative CFS are also under
742 consideration (see Figure 24). The authors of this paper are actively working on optimising
743 these sections by considering the section moment capacities. Moreover, as shown in Figure 25
744 and Figure 26, authors are also involving in studies of analysing full-scale floor panel, full-
745 scale corner post module, full-scale mid-rise, and high-rise modular buildings through
746 advanced FE method and structural tests. The current stage involves developing full-scale FE
747 models to investigate the global behaviour of modular buildings rather than component base
748 investigations. All the inter-module connections, intra-module connections, and module to
749 foundation connections are necessary to be incorporated into full-scale FE models, which will
750 be a challenging task.

751
752
753
754
755
756
757
758
759
760
761
762
764
765
766
767
768
769
770
771
772
773
774
775
776
777
778
779
780
781
782
783
784

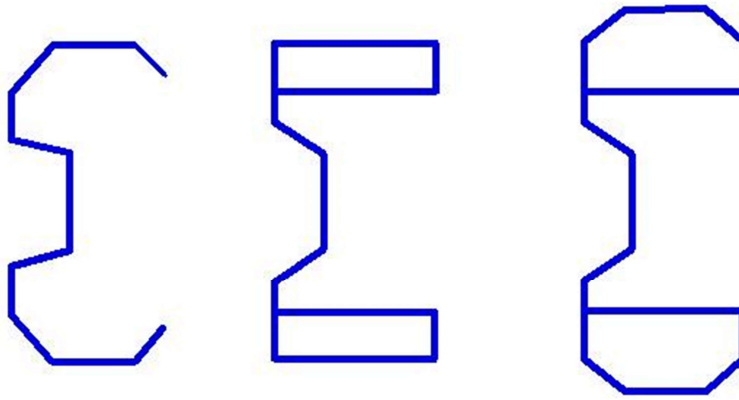

Figure 24: Innovative CFS sections under consideration

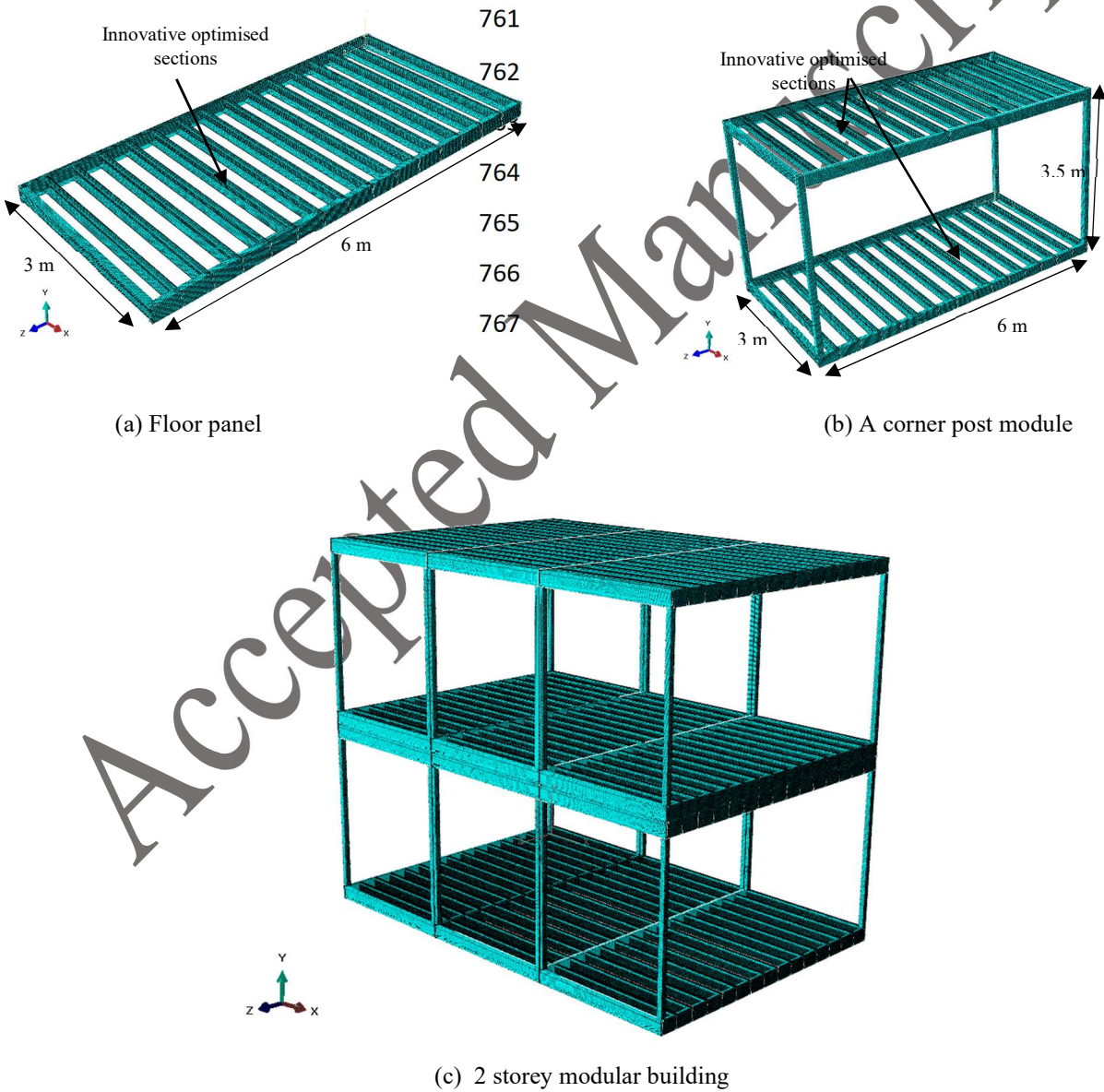
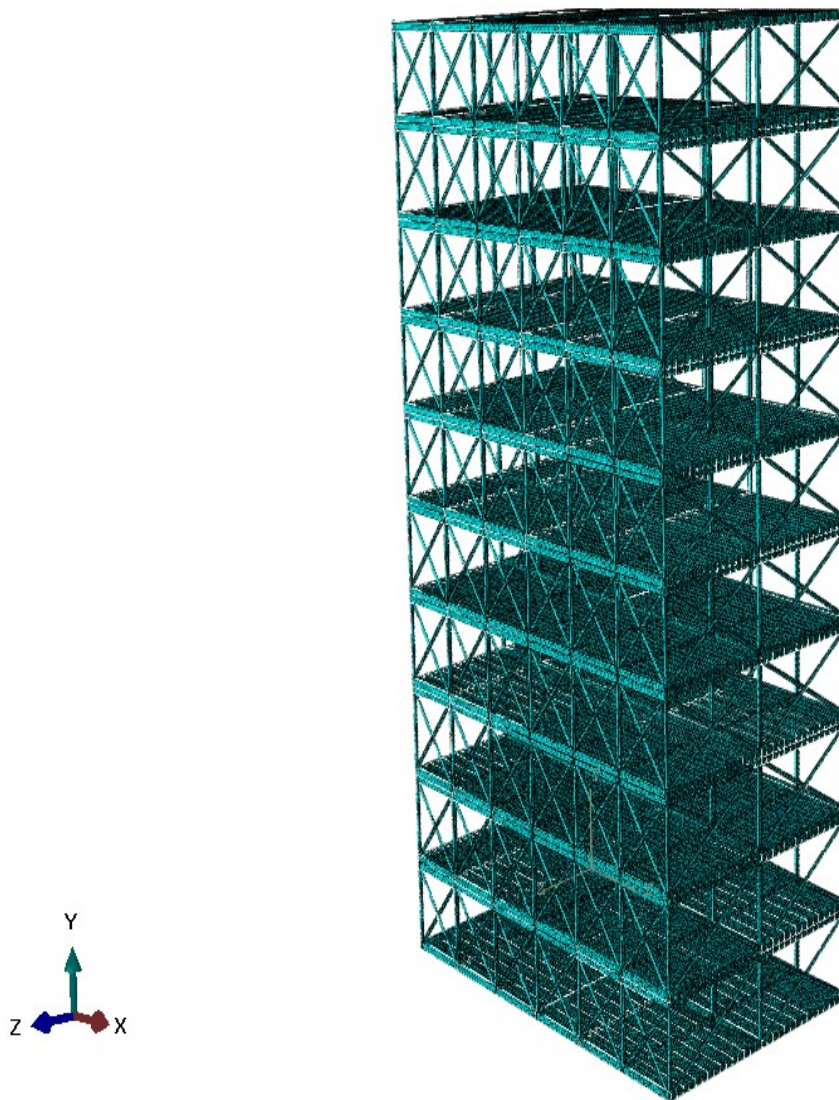

Figure 25: FE model development of MBS using optimised innovative sections



785

786

787 Figure 26: Full scale FE model development of high rise modular building supported with bracings

788 8 Concluding remarks

789 The construction industries in the UK are unable to meet the present housing crisis. MBS has
790 the potential to solve the housing crisis owing to its high productivity, enhanced structural
791 performance and shorter construction period. Wider benefits associated with cost reductions,
792 reduce risk of delivery on time and budget, and improved resource efficiency in terms of
793 materials and energy used can also be delivered with the use of MBS, raising its potential
794 market penetration in the future. This research proposes to employ the optimised CFS sections
795 with and without slotted perforations into MBS to improve structural, fire, and energy
796 performances. The optimisation of novel sections using PSO revealed an enhanced flexural

797 capacity of approximately 30%, 60% and 65 % for LCB optimised, Folded-Flange and Super-
798 Sigma sections, respectively. These capacities were verified with FE analyses. It is highly
799 recommended to employ the Super-Sigma sections into MBS as it claims the dual advantage
800 of enhanced structural performance (65% for solid web and 57% for slotted perforated web)
801 and closer shear centre to the outer web. The latter will result in less need of additional lateral
802 restrains in order to prevent the twisting effect. Further, it was found that incorporating
803 optimised sections with slotted perforations into MBS is able to meet the recently identified
804 challenges through recent research studies. Such optimised novel CFS sections are, therefore,
805 proposed to be used in light gauge steel frameworks and modular building systems in order to
806 enhance the structural, fire, and energy performances.

807 *Acknowledgements*

808 The authors of this paper would like to acknowledge Northumbria University and MMC
809 ENGINEER LTD for the financial support, necessary research facilities, and technical support.

810 **References**

- 811 [1] S. Navaratnam, T. Ngo, T. Gunawardena, D. Henderson, Performance Review of
812 Prefabricated Building Systems and Future Research in Australia, *Buildings*. 9 (2019)
813 38. doi:10.3390/buildings9020038.
- 814 [2] E. Generalova, V. Generalov, A. Kuznetsova, Modular Buildings in Modern
815 Construction, *Procedia Engineering*. 153 (2016) 167-172.
816 doi:10.1016/j.proeng.2016.08.098.
- 817 [3] D. O'Neill, S. Organ, A literature review of the evolution of British prefabricated low-
818 rise housing, *Structural Survey*. 34 (2016) 191-214. doi:10.1108/ss-08-2015-0037.
- 819 [4] S. Velamati, Feasibility, benefits and challenges of modular construction in high rise
820 development in United States: A developer's perspective, MSc, Massachusetts Institute
821 of Technology, 2012.
- 822 [5] W. Wilson, C. Barton, Tackling the under-supply of housing in England, House of
823 Commons, 2018. [http://researchbriefings.files.parliament.uk/documents/CBP-](http://researchbriefings.files.parliament.uk/documents/CBP-7671/CBP-7671.pdf)
824 [7671/CBP-7671.pdf](http://researchbriefings.files.parliament.uk/documents/CBP-7671/CBP-7671.pdf) (accessed 7 May 2019).
- 825 [6] Off-site manufacture construction: Building for change, 2nd ed., Authority of the House
826 of Lords, 2018.
827 <https://publications.parliament.uk/pa/ld201719/ldselect/ldsctech/169/169.pdf>
828 (accessed 7 May 2019).

- 829 [7] Modular construction for multifamily affordable housing, 2018.
830 <https://cdn.ymaws.com/www.nibs.org/resource/resmgr/oscc/epa-modular->
831 [construction-for.pdf](https://cdn.ymaws.com/www.nibs.org/resource/resmgr/oscc/epa-modular-construction-for.pdf) (accessed 7 May 2019).
- 832 [8] Liew, Y. Chua, Z. Dai, Steel concrete composite systems for modular construction of
833 high-rise buildings, *Structures*. (2019). doi:10.1016/j.istruc.2019.02.010.
- 834 [9] W. Ferdous, Y. Bai, T. Ngo, A. Manalo, P. Mendis, New advancements, challenges and
835 opportunities of multi-storey modular buildings – A state-of-the-art review,
836 *Engineering Structures*. 183 (2019) 883-893. doi:10.1016/j.engstruct.2019.01.061.
- 837 [10] A. Lacey, W. Chen, H. Hao, K. Bi, Structural response of modular buildings – An
838 overview, *Journal of Building Engineering*. 16 (2018) 45-56.
839 doi:10.1016/j.jobe.2017.12.008.
- 840 [11] H. Adeli, A. Karim, Neural Network Model for Optimization of Cold-Formed Steel
841 Beams, *Journal of Structural Engineering*. 123 (1997) 1535-1543.
842 doi:10.1061/(asce)0733-9445(1997)123:11(1535).
- 843 [12] J. Lee, S. Kim, H. Park, B. Woo, Optimum design of cold-formed steel channel beams
844 using micro Genetic Algorithm, *Engineering Structures*. 27 (2005) 17-24.
845 doi:10.1016/j.engstruct.2004.08.008.
- 846 [13] K. Magnucki, M. Maćkiewicz, J. Lewiński, Optimal design of a mono-symmetrical
847 open cross section of a cold-formed beam with sinusoidally corrugated flanges, *Thin-*
848 *Walled Structures*. 44 (2006) 554-562. doi:10.1016/j.tws.2006.04.016.
- 849 [14] T. Tran, L. Li, Global optimization of cold-formed steel channel sections, *Thin-Walled*
850 *Structures*. 44 (2006) 399-406. doi:10.1016/j.tws.2006.04.007.
- 851 [15] J. Ye, I. Hajirasouliha, J. Becque, A. Eslami, Optimum design of cold-formed steel
852 beams using Particle Swarm Optimisation method, *Journal Of Constructional Steel*
853 *Research*. 122 (2016) 80-93. doi:10.1016/j.jcsr.2016.02.014.
- 854 [16] J. Ye, I. Hajirasouliha, J. Becque, K. Pilakoutas, Development of more efficient cold-
855 formed steel channel sections in bending, *Thin-Walled Structures*. 101 (2016) 1-13.
856 doi:10.1016/j.tws.2015.12.021.
- 857 [17] P. Gatheeshgar, K. Poologanathan, S. Gunalan, B. Nagaratnam, K. Tsavdaridis, J. Ye,
858 Structural behaviour of optimized cold-formed steel beams, *Steel Construction*. (2020).
859 doi:10.1002/stco.201900024.

- 860 [18] N. Degtyareva, P. Gatheeshgar, K. Poologanathan, S. Gunalan, M. Lawson, P. Sunday,
861 Combined bending and shear behaviour of slotted perforated steel channels: Numerical
862 studies, *Journal Of Constructional Steel Research*. 161 (2019) 369-384.
863 doi:10.1016/j.jcsr.2019.07.008.
- 864 [19] G. Perampalam, R. Dobson, K. Poologanathan, K. Tsavdaridis, B. Nagaratnam, E.
865 Iacovidou, *Modular Building Design: Post- Brexit Housing*, in: *The 14Th Nordic Steel*
866 *Construction Conference, NORDIC STEEL 2019, Copenhagen, Denmark, 2019*.
- 867 [20] W. Macht, *Steel Modules Speed Construction*, Urban Land Institute, 2019.
868 [https://www.panoramic.com/wp-content/uploads/2018/12/Steel-Modules-Speed-](https://www.panoramic.com/wp-content/uploads/2018/12/Steel-Modules-Speed-Construction-Macht-W-2019-86-91.pdf)
869 [Construction-Macht-W-2019-86-91.pdf](https://www.panoramic.com/wp-content/uploads/2018/12/Steel-Modules-Speed-Construction-Macht-W-2019-86-91.pdf) (accessed 9 May 2019).
- 870 [21] R. Lawson, R. Ogden, R. Bergin, *Application of Modular Construction in High-Rise*
871 *Buildings*, *Journal of Architectural Engineering*. 18 (2012) 148-154.
872 doi:10.1061/(asce)ae.1943-5568.0000057.
- 873 [22] Modular Building Institute, *Modular.Org*. (2013).
874 http://www.modular.org/HtmlPage.aspx?name=why_modular (accessed 7 May 2019).
- 875 [23] R. Smith, *Off-Site Modular Construction Explained*, Off-Site Construction Council,
876 national Institute of Building Sciences, 2016.
877 https://cdn.ymaws.com/www.nibs.org/resource/resmgr/OSCC/OSMC_Explained.pdf
878 (accessed 9 May 2019).
- 879 [24] M. Kamali, K. Hewage, *Life cycle performance of modular buildings: A critical review*,
880 *Renewable and Sustainable Energy Reviews*. 62 (2016) 1171-1183.
881 doi:10.1016/j.rser.2016.05.031.
- 882 [25] Lawson RM, Ogden RG. *Sustainability and process benefits of modular construction*.
883 In: *Proceedings of the 18th CIB World Building Congress, TG57-Special Track*.
884 Salford, UK; May 10–13, 2010. p. 38–51.
- 885 [26] E. Iacovidou, P. Purnell, *Mining the physical infrastructure: Opportunities, barriers and*
886 *interventions in promoting structural components reuse*, *Science of The Total*
887 *Environment*. 557-558 (2016) 791-807. doi:10.1016/j.scitotenv.2016.03.098.
- 888 [27] L. Aye, T. Ngo, R. Crawford, R. Gammampila, P. Mendis, *Life cycle greenhouse gas*
889 *emissions and energy analysis of prefabricated reusable building modules*, *Energy And*
890 *Buildings*. 47 (2012) 159-168. doi:10.1016/j.enbuild.2011.11.049.

- 891 [28] S. Alonso-Zandari, A. Hashemi, Prefabrication in the UK housing construction
892 industry, in: 5th International Conference on Zero Energy Mass Customised Housing-
893 ZEMCH 2016, 2016.
- 894 [29] HNF Property | World's tallest modular building under construction in Croydon, HNF
895 Property. (2019). [https://www.hnfproperty.com/worlds-tallest-modular-building-
896 under-construction-in-croydon/](https://www.hnfproperty.com/worlds-tallest-modular-building-under-construction-in-croydon/) (accessed 10 May 2019).
- 897 [30] A. Welch, World's Tallest Modular Buildings, Croydon - e-architect, E-Architect.
898 (2019). [https://www.e-architect.co.uk/london/worlds-tallest-modular-buildings
899](https://www.e-architect.co.uk/london/worlds-tallest-modular-buildings) (accessed 10 May 2019).
- 900 [31] The Height of Design, Tide Construction Limited and Visions Modular Systems UK
901 Ltd, 2018. [https://www.buildoffsite.com/content/uploads/2018/07/Tide-and-Vision-
902 Presentation-Buildoffsite-The-Height-of-Design-4th-July-2018.pdf](https://www.buildoffsite.com/content/uploads/2018/07/Tide-and-Vision-Presentation-Buildoffsite-The-Height-of-Design-4th-July-2018.pdf) (accessed 10 May
903 2019).
- 904 [32] T. Gunawardena, T. Ngo, P. Mendis, J. Alfano, Innovative Flexible Structural System
905 Using Prefabricated Modules, *Journal of Architectural Engineering*. 22 (2016)
906 05016003. doi:10.1061/(asce)ae.1943-5568.0000214.
- 907 [33] Melbourne Home to Australia's Tallest Prefabricated Building, *The Urban Developer*.
908 (2016). [https://theurbandeveloper.com/articles/melbourne-home-australias-tallest-
909 prefabricated-building](https://theurbandeveloper.com/articles/melbourne-home-australias-tallest-prefabricated-building) (accessed 10 May 2019).
- 910 [34] I. Block, BIG's timber housing in Stockholm is designed to look like a hill, *Dezeen*.
911 (2019). [https://www.dezeen.com/2018/11/09/big-76-park-stockholm-modular-timber-
912 apartments-architecture/](https://www.dezeen.com/2018/11/09/big-76-park-stockholm-modular-timber-apartments-architecture/) (accessed 13 May 2019).
- 913 [35] C. Coello, S. Dehuri, S. Ghosh, *Swarm Intelligence for Multi-objective Problems in
914 Data Mining*, Springer Berlin Heidelberg, Berlin, Heidelberg, 2009.
- 915 [36] CEN, Eurocode 3: Design of Steel Structures, Part 1.3: General Rules—Supplementary
916 Rules for Cold-formed Steel Members and Sheeting, in, Brussels:European Committee
917 for Standardization, 2006.
- 918 [37] CEN, Eurocode 3: Design of Steel Structures, part 1-5: Plated Structural Elements, in,
919 Brussels: European Committee for Standardization, 2006.
- 920 [38] Mathworks, Matlab R2017a, in, Mathworks, Inc, 2017
- 921 [39] Abaqus CAE, ABAQUS inc., N/A, 2017.

- 922 [40] P. Keerthan, M. Mahendran, New design rules for the shear strength of LiteSteel beams,
923 Journal of Constructional Steel Research. 67 (2011) 1050-1063.
924 doi:10.1016/j.jcsr.2010.11.010.
- 925 [41] L. Sundararajah, M. Mahendran, P. Keerthan, New design rules for lipped channel
926 beams subject to web crippling under two-flange load cases, Thin-Walled Structures.
927 119 (2017) 421-437. doi:10.1016/j.tws.2017.06.003.
- 928 [42] P. Keerthan, M. Mahendran, Improved shear design rules for lipped channel beams with
929 web openings, Journal of Constructional Steel Research. 97 (2014) 127-142.
930 doi:10.1016/j.jcsr.2014.01.011.
- 931 [43] L. Wang, B. Young, Design of cold-formed steel channels with stiffened webs
932 subjected to bending, Thin-Walled Structures. 85 (2014) 81-92.
933 doi:10.1016/j.tws.2014.08.002.
- 934 [44] C. Pham, G. Hancock, Experimental Investigation and Direct Strength Design of
935 High355 Strength, Complex C-Sections in Pure Bending, Journal of Structural
936 Engineering. 139 356 (2013) 1842-1852. doi:10.1061/(asce)st.1943-541x.0000736.
- 937 [45] C. Pham, Direct Strength Method of Design of Cold-Formed Sections in Shear, and
938 Combined Bending and Shear, Ph.D The University of Sydney, 2010.
- 939 [46] M. Naser, N. Degtyareva, Temperature-induced instability in cold-formed steel beams
940 with slotted webs subject to shear, Thin-Walled Structures. 136 (2019) 333-352.
941 doi:10.1016/j.tws.2018.12.030.
- 942 [47] M. Lawson, R. Ogden, C. Goodier, Design in modular construction, 2014.
- 943 [48] M. Lawson, Building design using modules, The Steel Construction Institute, 2007.
- 944