

# Article Title Page

[Development of multiscale multi-physics based modelling and simulations with the application to precision machining of aerofoil structures]

## Author Details:

[Yizhi Shao]  
[Brunel University]

[O.B. Adetoro ]  
[Brunel University]

[Kai Cheng]  
[Brunel University]

Corresponding author: [Kai Cheng]  
[kai.cheng@brunel.ac.uk]

*NOTE: affiliations should appear as the following: Department (if applicable); Institution; City; State (US only); Country. No further information or detail should be included*

## Acknowledgments (if applicable):

## Biographical Details (if applicable):

[Author 1 bio]

[Author 2 bio]

[Author 3 bio]

[Author 4 bio]

## Structured Abstract:

Multiscale multi-physics based modelling and simulations are getting more and more interest by research community and the industry particularly in the context of increasing demands for manufacturing high precision complex products and understanding the associated complexity in manufacturing processes. With the development of multiscale multi-physics based modelling and simulation, it will enable effective and efficient optimisation of manufacturing processes and further improvement of manufacturing quality, costs, delivery time and the overall competitiveness. In this paper, some modelling and analysis techniques using multiscale multi-physics modelling are presented and discussed. Furthermore, the possibility of adopting the multiscale multi-physics modelling and simulation to develop the virtual machining system is evaluated, and further supported with an industrial case study on Abrasive Flow Machining (AFM) of integrally bladed rotors (IBR) using the techniques and system developed.

## Keywords:

Multiscale modelling; Multi-physics simulation; Precision machining; Abrasive flow machining; Aerofoil structures

## Article Classification:

Research Paper

---

*For internal production use only*

## Running Heads:



## Development of multiscale multi-physics based modelling and simulations with the application to precision machining of aerofoil structures

Yizhi Shao, O.B. Adetoro and Kai Cheng\*

Institute of Materials and Manufacturing

Brunel University London, Uxbridge UB8 3PH, UK

\*Emails: [kai.cheng@brunel.ac.uk](mailto:kai.cheng@brunel.ac.uk); [yizhi.shao@brunel.ac.uk](mailto:yizhi.shao@brunel.ac.uk)

**Abstract:** Multiscale multi-physics based modelling and simulations are getting more and more interest by research community and the industry particularly in the context of increasing demands for manufacturing high precision complex products and understanding the associated complexity in manufacturing processes. With the development of multiscale multi-physics based modelling and simulation, it will enable effective and efficient optimisation of manufacturing processes and further improvement of manufacturing quality, costs, delivery time and the overall competitiveness. In this paper, some modelling and analysis techniques using multiscale multi-physics modelling are presented and discussed. Furthermore, the possibility of adopting the multiscale multi-physics modelling and simulation to develop the virtual machining system is evaluated, and further supported with an industrial case study on Abrasive Flow Machining (AFM) of integrally bladed rotors (IBR) using the techniques and system developed.

**Keywords:** Multiscale modelling; Multi-physics simulation; Precision machining; Abrasive flow machining; Aerofoil structures

### 1. Introduction

Engineering modelling and simulation are increasingly applied for industrial purposes in different scales and various engineering fields, such as those focusing on the structures which are analysed by macroscopic models while some using microscopic models to improve the component accuracy on its form, dimension and surface profiles. Some modelling and simulations based on different physical principles are applied to analyse the manufacturing process by taking account of various factors. However, in precision engineering cases, the underlying process and system are commonly complex, i.e. involving mechanical, electrical, optical elements operating in multiple scales simultaneously. For instance, the heat transfer, air lubrication and electric-magnetic fields within a direct drive aerostatic bearing supported slideway, the above-mentioned various factors affect each other, which is critically essential in working towards high precision. Therefore, it is necessary and important to develop multiscale multiphysics based modelling and simulations in supporting precision engineering analysis particularly for rendering simulation accuracy and the corresponding precision machining efficiency. Furthermore, it is of great significance to establishing an industrial feasible approach that is able to bridge the gaps in undertaking precision and micro/nano manufacturing at a truly predictable, producible and highly productive manner[1].

In recent years, it can be found that many breakthroughs in multiscale modelling and the associated computational methods developed in different R&D areas and application fields. Those developments have applied to material science, chemistry, biology, fluid mechanics and precision engineering[2], such as the nonlocal quasi-continuum method (QC) for simulating isolated defects including dislocations and cracks in single crystals. The method is conceived and developed by Tadmor, Ortiz and Phillips in 1996[3]. The DSMC-gas dynamics modelling method is also a multiscale modelling method used in solving fluid mechanics problem, which is a very elegant extension of the adaptive mesh refinement procedure developed through the years by Bell, Berger, Colella et al[4]. However, those research and development are related to multiscale modelling and simulations limited in one phase simulation. On the other hand, Multiphysics analysis software tools and Multiphysics modelling applications have been gaining substantial advances,

although numerous software engineering challenges are still remained particularly in effective coupling, integration and complex problem-solving. Those Multiphysics tools provide opportunities for long-term research focusing on accurate, robust, stable, efficient and scalable Multiphysics modeling and analysis algorithms, with extensibility for application-specific customization and so on. If the application and simulation involve objectives in various dynamic states and physical fields as it often is, it should be likely to simulate it through the integration of Multiphysics modelling and analysis and thus lead to the best optimum solutions.

In this paper, the development and application of several multiscale and multi-physics modelling and analysis were introduced at first, particularly focusing on the core principles of some comparatively advanced ones. The modelling methods are presented separately by different scales and physical fields. Then some application exemplars are presented to show how different scales and physical fields are combined and integrated in the simulations. The interaction between different scales and physical fields is essentially important for industrial research and development because of the complexity and interdisciplinary nature involved. A real industrial case study is further introduced based on multiscale multi-physics modelling and simulation. Through the Abrasive Flow Machining (AFM) application, the rationality and feasibility of using the multiscale and multiphysics modelling and simulation are discussed and explored. Finally, the potential and future development of the approach are reviewed and further discussed.

## 2. Multiscale multi-physics modelling, simulation, and precision machining

### 2.1 Multiscale modelling and simulation

#### 2.1.1 Fundamental overview

As a multiscale modelling and simulation, it is important to discuss the model in different scales. The equations and theories have been divided into four different scales against the computational time as illustrated in Figure 1 [2]. Those fundamental theories and the associated implementation approaches are used to solve industrial problems on various orders of magnitude. The following description attempts to discuss some examples of each scale in a highly summative manner.

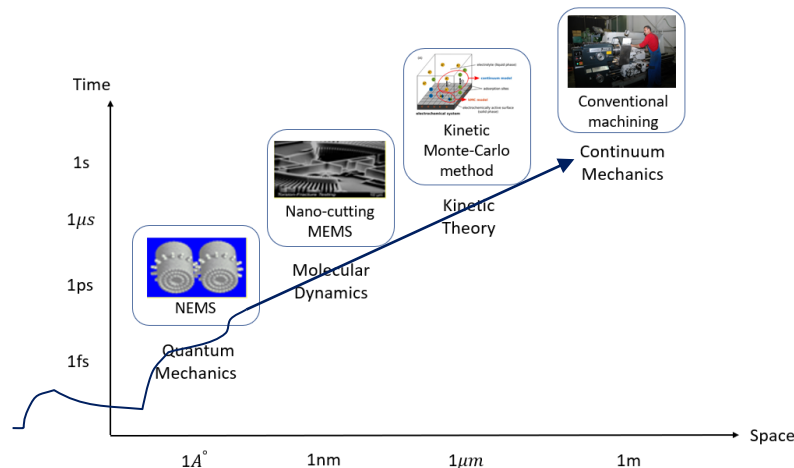

Figure 1 Illustration of models on four different scales against the computational time

Continuum mechanics models, such as the Euler's equation and the Navier-Stokes equation, are the crudest in this hierarchy, which only concentrates on the macroscopic density, velocity and temperature fields of the fluid. Nevertheless, they are already quite sufficient in many engineering applications. Quantum mechanics models are the most detailed ones. They are required if we are interested in the details of the collision process between gas particles. Molecular dynamics models are of the intermediate complexity,

which respectively captures the phase space probability distribution and the phase space dynamics of the fluid particles in the non-Newtonian fluid. Kinetic theory serves as a connection between continuum and atomistic models. It can either be viewed as an approximation to the hierarchy of equations for the many-particle probability densities obtained from molecular dynamics or as a microscopic model for the phase-space probability distribution of a particle, from which continuum models can be derived[2].

### 2.1.2 The Oldroyd-B model based on Continuum Mechanics and Molecular Dynamics

Some fluids called complex or non-Newtonian fluids are widely used for industrial purpose. They include muds, fresh concrete, paints, and medias used in many non-traditional machining. In many cases, this particular behaviour originates from the presence of some microstructures within the fluid that is strongly coupled to the solvent dynamics, especially some of the fluid dynamics owns high viscosity itself. Deriving solutions of flexible polymer chains is necessary. A dilute solution of polymer chains consists of a solvent and polymer chains floating therein. These chains are in such a small quantity that direct interactions between the chains can be neglected[5-6]. As described in the example of Oldroyd-B model in Le Bris literature, a polymer chain is meant to be a long linear molecule built as the repetition of an elementary pattern, called the monomer (think typically of an alkane molecule  $\text{CH}_3(\text{CH}_2)_n\text{CH}_3$ ). It is observed that the rheology of the fluid (that is the way it flows) is very much affected by the polymer chains, even at a minimal concentration.

Oldroyd-B model is a microscopic-macroscopic (in short micro-macro) model to describe such high viscosity fluids. The modelling principle of Oldroyd-B model is to couple conservation laws on macroscopic quantities (such as the velocity or the stress) while using some other models for the evolutions of microstructures. With the combination of these model, the simulation will stay a high accuracy of calculation and not have a huge cost as most of the part is stay on macroscopic modelling and simulation. The modelling part can be described by two mainly equation as follows:

Modelling of non-Newtonian fluids starts with the mass and momentum conservation equations for incompressible fluids:

$$\mathbf{T} + \lambda_1 \overset{\nabla}{\mathbf{T}} = 2\bar{\eta}_0(\mathbf{D} + \lambda_2 \overset{\nabla}{\mathbf{D}}) \quad \nabla$$

Where:

$\mathbf{T}$  - the stress tensor;

$\lambda_1$  - the relaxation time;

$\lambda_2$  - the retardation time =  $\frac{\eta_s}{\eta_0} \lambda_1$ ;

$\overset{\nabla}{\mathbf{T}}$  is the upper convected time derivative of stress tensor;

$$\overset{\nabla}{\mathbf{T}} = \frac{\partial}{\partial t} \mathbf{T} + \mathbf{v} \cdot \nabla \mathbf{T} - ((\nabla \mathbf{v})^T \cdot \mathbf{T} + \mathbf{T} \cdot (\nabla \mathbf{v})); \quad (2)$$

Where:

$\mathbf{v}$  is the fluid velocity;

$\eta_0$  is the total viscosity composed of solvent and polymer components,  $\eta_0 = \eta_s + \eta_p$ ;

$\mathbf{D}$  is the deformation rate tensor or rate of strain tensor,  $\mathbf{D} = \frac{1}{2} [\nabla \mathbf{v} + (\nabla \mathbf{v})^T]$ .

The models for polymer chains can be written separately as:

$$\mathbf{T} = 2\eta_s \mathbf{D} + \tau \quad (3)$$

Where,  $\mathbf{T}$  is the stress tensor, and  $\mathbf{D}$  is the deformation rate tensor or rate of strain tensor,

### 2.1.3 The Hertz theory for Micro-cutting mechanics modelling in Abrasive Flow Machining

It is necessary to find a physical modelling method to simulate the grinding process across the surface. The Hertz theory is widely applied in grinding process for prediction of indentation depth[7]. As AFM process is in many ways similar to grinding process, Hertz theory can be applied in AFM process for similar estimation. According to Hertz, the contact area for elastic contact between sphere of radius and a flat surface can be evaluated from:

$$\bar{\sigma} = 0.41 \times \sqrt[3]{\frac{F'_{ng} E_m^2}{4R^2}} \quad (4)$$

$E_m$  denotes the Young's modulus of elasticity of the work piece surface and  $R$  denotes the spherical radius.  $F'_{na}$  represents the normal force acting on the cutting tool. With this theory the depth of indentation for elastic loading is given by:

$$d' = 1.55 \times \sqrt[3]{\frac{F'_{ng}{}^2}{2RE_m^2}} \quad (5)$$

In this equation the depth of cutting by each grain can be solved numerically. But it is still not clear which type of cutting it is in current situation. The maximum value of stress at contact area will be equal during plastic deformation will be equal to the Brinell Hardness of the material, thus following expression is derived:

$$\frac{d'}{2R} = 9.22 \left[ \frac{H_W}{E_m} \right]^2 \quad (6)$$

This expression is known as the criteria for determining different interaction regime between the work piece and the abrasive grains, three regimes were identified:

- Chip forming regime:  $\frac{d'}{2R} > 0.029$
- Plastic regime:  $9.22 \left[ \frac{H_W}{E_m} \right]^2 < \frac{d'}{2R} < 0.029$
- Elastic regime:  $\frac{d'}{2R} < 9.22 \left[ \frac{H_W}{E_m} \right]^2$

The criteria show that when the penetration depth is below 6% of the grain radius, the chip will not form and the depth is below 0.058R then the displaced material will form ridges by undergoing plastic deformation and no metal will be removed. If the depth is less than the third equation, the grains will slide across the surface and no plastic deformation will occur. With this rule applied to each grain in AFM process, it is possible to simulate the manufacturing across micro scale which contributes to surface roughness and the generation of surface texture.

## 2.2 Multiphysics modelling and simulation

### 2.2.1 Introduction to Multi-physics modelling and simulation

The models on different physical fields also can be interactive to each other and contribute to multiphysics modelling and simulation. Additionally, the physical models also based on multiscale, multi physics considerations are at least as important, if not more[2]. After all, the ultimate goal of modelling is to get a better understanding of the physical problem and obtaining better models is a significant way of getting

the better understanding. Also, there is a very close relation between multi scale algorithms and multiscale models. The example modelling methods in different states show in Table 1.

Gases, plasmas	Liquids	Solids
Gas dynamics MHD	Hydrodynamics (Navier-Stokes)	Elasticity models Plasticity models
		Dislocation dynamics
Kinetic theory	Kinetic theory	
	Brownian dynamics	Kinetic Monte Carlo
Particle models	Molecular dynamics	Molecular dynamics
Quantum mechanics	Quantum mechanics	Quantum mechanics

Table 1 Model with different states

Not only on the different states should be considered in the multi-physics simulation, but also different physical fields such as heat transfer, electricity fields and chemical reactions.

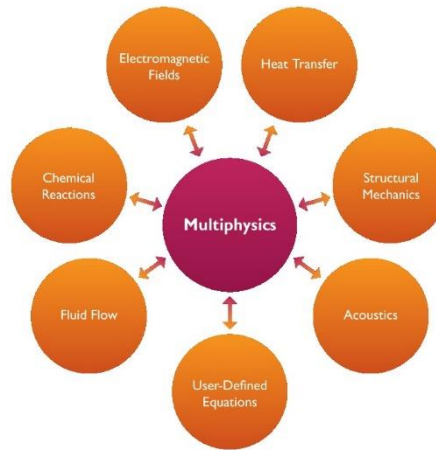

Figure 2 Different physical fields can be involved by Multiphysics modelling and simulation

### 2.2.2 Interaction between structure and fluid model

Fluid–structure interaction (FSI) is the interaction between the deformable or movable structure and fluid flow[8-12]. It is widely used in many different industrial fields which include fluid and the fluid influences the manufacturing process. There are two main approaches exist for the simulation of fluid–structure interaction problems. One is Monolithic approach while the other one is the Partitioned approach. The equations in Monolithic approach governing the flow and the displacement of the structure are solved simultaneously, with a single solver. The other one solves the displacement of the structure separately, with two distinct solvers. Each of them owns its advantages and disadvantages.

There is a mathematical model called Newton–Raphson method can be used to solve FSI problems. The methods based on Newton–Raphson iteration can be used in both of the two approaches listed below. These methods use the structural equations and the nonlinear flow equations on the structure and fluid domain. The system of linear equations within the Newton–Raphson iteration can be solved with this method and provide the result of FSI problems.

The FSI model equation can be described by two parts as follow:

Fluid flow:

$$\rho \frac{\partial u}{\partial t} - \nabla \cdot [-pI + \eta(\nabla u + (\nabla u)^T)] + \rho((u - u_m) \cdot \nabla)u = F \quad (7)$$

$$-\nabla \cdot \mathbf{u} = 0 \quad (8)$$

In this equation,  $I$  denote the unit diagonal matrix and  $F$  is the volume force affecting the fluid. Assume that no gravitation or other volume forces affect the fluid so that  $F = 0$ . The coordinate system velocity is  $\mathbf{u}_m = (u_m, v_m)$ .

Structural mechanics:

$$\mathbf{F}_T = -\mathbf{n} \cdot (-p\mathbf{I} + \eta(\nabla\mathbf{u} + (\nabla\mathbf{u})^T)) \quad (9)$$

where  $\mathbf{n}$  is the normal vector to the boundary

### 2.3 Multiscale model and simulation on precision machining process and the associated surface generation

In Luo's research, a natural approach to the simulation of multiscale processes is to combine an MD simulation for the critical regions within the system with an FE method for a continuum description. The QC model can be used to solve this problem on the manufacturing of solid structure. This approach provides an atomistic description near the interface and a continuum description deep into the substrate, increasing the accessible length scales and significantly reducing the computational cost. It has referential value on building different kinds of machining process. The multiscale model shows great impact on simulating the Continuum Mechanics and Molecular Dynamics which contributes both the predict of material removal and surface texture. It is necessary to find out how to provide the prediction of surface texture on specific areas we need without influence the simulation of other parts during the processing time.

In Abrasive flow machining, it is also essential to simulate the surface generation. In the multiscale model it can be divided in two parts, one is the CFD module and the other one is the micro cutting mechanics modelling. The CFD module can simulate the media flow and provide the required specification for the micro cutting mechanics model. The Micro cutting mechanics model is built on the mechanics for one grain and with the help of Monte Carlo Algorithm the simulation can be accumulated to mass of grains in the flow. With this combination the surface generation can be predicted by the simulation program[13-17].

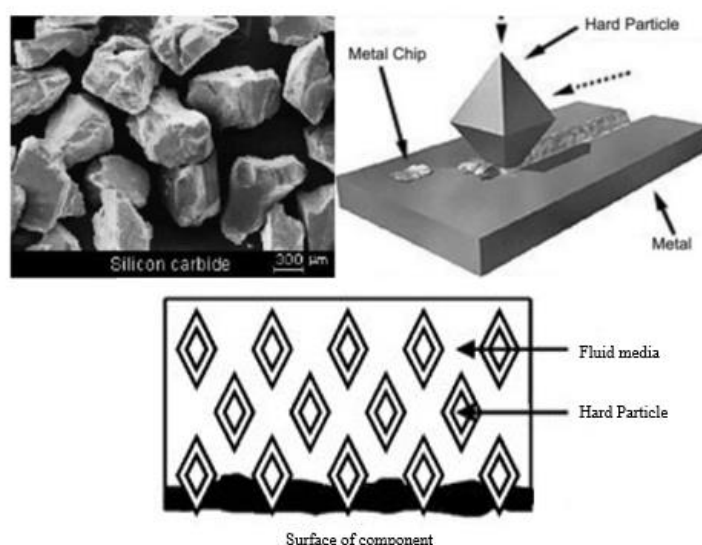

Figure 3 Grains in Fluid Media which used in Abrasive Flow Machining process

## 2.4 Simulation based virtual machining system and the process optimisation

With the development of computer simulation software, a concept about virtual manufacturing system has been brought out. Virtual manufacturing is the use of computers to model, simulate and optimise the critical operation parameters on the manufacturing machine and entities in factory or plant. Nowadays the virtual manufacturing system turns to be a way to design and test machine tools and expands

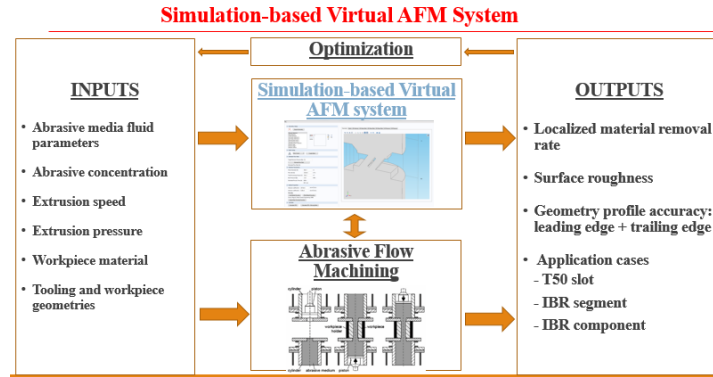

Figure 4 Methodology illustration and architecture of the virtual AFM system

to involve production processes and the products themselves. It can dramatically decrease the manufacturing process time and funding on the test. Now with the help of multi-physics modelling and simulation, many environmental factors can be considered in to optimise the production process. As discussed in the next section below, a Virtual AFM System has been brought out with the help of multiscale multi-physics modelling and simulation. The methodology shows in Figure 4 and the GUI of Virtual AFM system is shown in Figure 5.

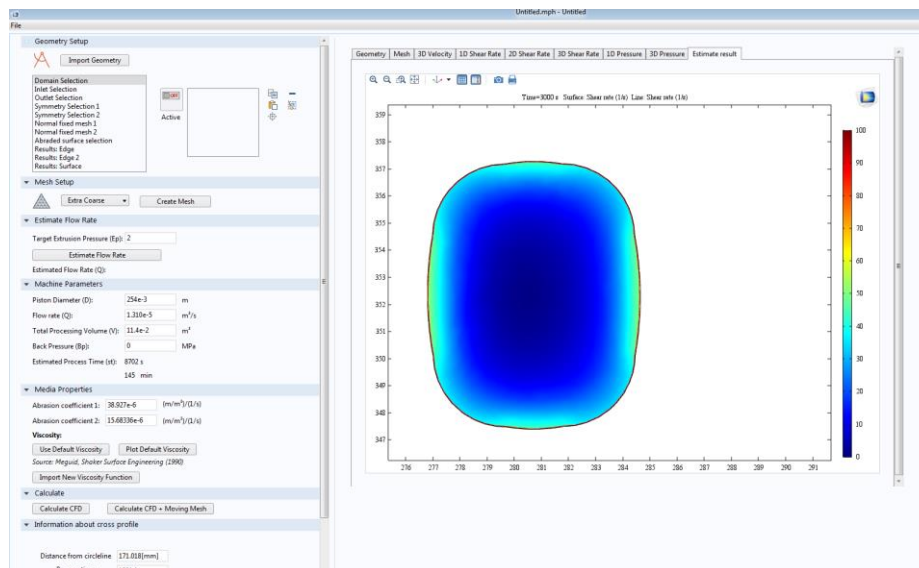

Figure 5 User interface of the virtual AFM system

## 3. Application case studies - Abrasive flow machining of integrally bladed rotors (IBRs)

### 3.1 Introduction on abrasive flow machining and specifications of integrally bladed rotors



Abrasive Flow Machining (AFM) was brought out in the 1960s by the Extrude Hone Corporation. In the aviation industry, AFM is performed by extruding viscoelastic media, through a workpiece featuring complex free-form aero structures which are inaccessible by hand to surface finish. Furthermore, AFM is an essential means for surface processing for 3D additive confirmed compound components. However, the process control needs to be more predictable, producible and highly productive manner. In this light, the prediction of abrasive flow machining (AFM) can improve the efficiency and performance of workpieces [18].

IBR manufacture, in particular, requires polishing the blades to a target SR while maintaining a tight control of the entire profile of the blades. With particular attention being paid to the geometry of the leading and trailing edges, the CFD based simulation of the process shown here could be especially helpful this application. Predicting MR along an entire profile and in multiple sections of the blade could significantly diminish the amount of testing and iterations required for obtaining the process parameters and be an invaluable aid when designing the rather complex tooling that is needed for this particular application of AFM[17-19].

In this case, multiscale multi-physics modelling and simulation are developed in the collaboration with COMSOL and MATLAB based on CFD module, Fluid-Structure Interaction module, Micro-cutting mechanics model and Monte-Carlo method. With the simulation, the material removal, profile accuracy and surface roughness of the workpiece can be predicted. With a well-designed experiment, the result of the simulation is being tested. On the test of experiment, a further simulation is discussed to be applied to the manufacturing process of the integrated bladed rotor. The result of the simulation is presented on the real result supported by ITP and Extruded Horn.

### 3.2 Multiscale multi-physics modelling and simulation on the IBR blade

*As a scientific and reliable production technique, readily available multi-physics simulation software, COMSOL can be used to analyse the flow of media in an arbitrary geometry. The CFD module in COMSOL makes it possible to simulate the Pressure Distribution and shear rate on the surface of a workpiece. With the appropriate setup of simulation, the result of Abrasive Flow Machining is predictable in controllable deviation.*

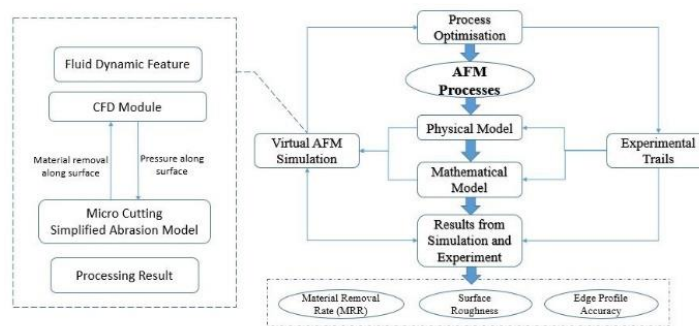

Figure 6 Introduction on the methodology

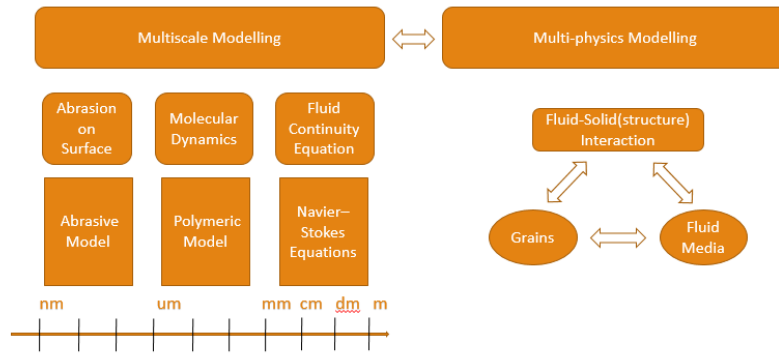

Figure 7 Structure of AFM virtual manufacturing system

### 3.2.1 CFD modelling based on multiscale

The CFD Module in COMSOL uses Navier-Stokes equations to model flows in all kinds of velocity regimes. All the simulation packages used to model fluid flow numerically solve the Navier Stokes equations, with the variation on the simplifying assumptions and constitutive models utilised for the internal stress related component. The equations are:

#### Conservation of momentum

$$\underbrace{\rho \frac{D\vec{v}}{Dt}}_{\text{Acceleration}} = \underbrace{-\nabla p}_{\text{Pressure}} + \underbrace{\nabla \cdot \underline{T}}_{\text{Internal Stress}} + \underbrace{\vec{f}}_{\text{Ext. forces}} \quad (10)$$

#### Conservation of mass

$$\frac{d\rho}{dt} + \nabla \cdot (\rho\vec{v}) = 0 \quad (11)$$

**The constitutive equation** that relates the internal stress in the fluid with the rate of deformation and deformation (in the case of a viscoelastic fluid) of a fluid element.

The different types of constitutive equations will be described below, and they are, at their core, a set of increasingly more detailed representations of how the material experiences stress when subject to different flow conditions.

Viscoelastic fluids can be modelled by more complex constitutive equations which consider the flexible time dependent response of the media. The Oldroyd-B model is a multiscale constitutive model used to describe the flow of non-Newtonian fluids. It consists of two part with different scales. The models available can be of the Oldroyd-B type which follows a differential equation that augments the stress term shown in the Navier-Stokes equations described above so that:

$$\underline{T} = \underbrace{\underline{T}_1}_{\text{Viscoelastic component}} + \underbrace{\underline{T}_2}_{\text{Purely viscous component}} \quad (12)$$

### 3.2.2 Abrasion process model based on Fluid-Structure Interaction model

**The abrasion model presented here is an example of how the flow simulation may be leveraged to produce data that can help an engineer predict the process response before first trials, reducing the amount of testing needed to develop a new part.**

This model makes two main assumptions about the material removal in any given condition:

The first assumption is that the material removal is higher at the place where the polymer slips faster against the wall. This phenomenon occurs when the simulated velocity gradient (shear rate) is greater. On the

other hand, the material removal rate is constant concerning the processed volume and may be estimated from two straight lines. One line is for the initial cycle where material removal is more aggressive while another one is for subsequent periods.

Given these two assumptions one may write an expression for the physical removal as a function of both the processed volume and the shear rate:

$$MRR_v(V, \dot{\gamma}_{simulated}) \left[ \frac{m}{m^3} \right] = K_{va}(V) \left[ \frac{m}{m^3 \cdot s^{-1}} \right] \cdot \dot{\gamma}_{simulated} [s^{-1}] \quad (13)$$

$$K_{va}(V) = \begin{cases} K_{va1} & \text{if } V \leq V_1 \\ K_{va2} & \text{if } V > V_1 \end{cases} \quad (14)$$

Where  $MRR_v$  is the material removal rate by volume (i.e. for each cubic meter of processed media),  $\dot{\gamma}_{simulated}$  is the shear rate at the wall obtained in simulation,  $K_{va1}$  and  $K_{va2}$  are proportionality constants which may be found by testing, which will depend on the media, abrasives and workpiece material used,  $V_1$  is the volume of the initial cycle where material removal is more aggressive.

It is necessary to apply this model to the method of moving mesh simulation, the displacement of the boundary needs to be programmed as a function of time not volume, the flow rate (Q) being pushed through the part is assumed constant so:

$$MRR_t \left[ \frac{m}{s} \right] = Q \left[ \frac{m^3}{s} \right] \cdot MRR_v \left[ \frac{m}{m^3} \right] \quad (15)$$

The main strength of this model is that it may be used to predict the localised material removal within a part, in the case of IBRs, it could be developed to predict the removal of the leading and trailing edges, and it will be helpful to predict the profile accuracy on the leading and trailing edges.

### 3.2.3 Interaction between CFD Model and Simplified Abrasion Model

**In this simulation, two different modules are running parallel and dynamically. This part is mainly contributing the Fluid-Structure Interaction modelling and simulation which predicts material removal rate possible. The CFD Module in this simulation provides the pressure distribution along the surface and the velocity of fluid media along the workpiece which is required in the calculation and prediction of material removal by Simplified Abrasion Model. On the other hand, the Simplified Abrasion Model also need to provide the material removal along the workpiece surface for CFD Module to update the profile of blade surface. With this type of communication between two models, it can predict the material removal and surface profile with process time on manufacturing.**

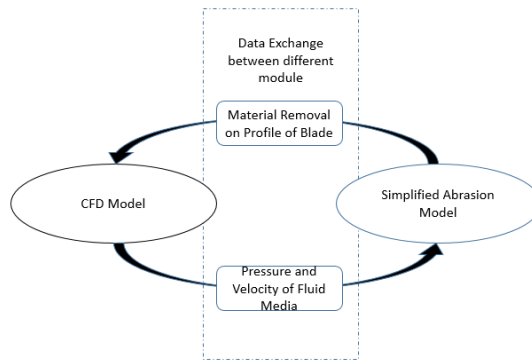

Figure 8 The interaction between the CFD Model and Abrasion Model

### 3.2.4 Micro-cutting mechanics model based on Hertz contact theory and Monte Carlo method

**With the help of CFD based simulation and Abrasion Model it is possible to simulate the surface roughness and even the surface texture of Abrasive Flow Machining. Since the pressure and velocity distribution of fluid can be predicted by the CFD module, it is necessary to find out a model to predict the micro-cutting mechanics on the surface with the grain properties. There are two part in this model which contains the generation of the grains and the cutting model of each grain.**

In this model the grains need to be generated randomly but follows the statistic distribution of the grains in real fluid media. There are two factors from the shape of grains influence the cutting model for grains: diameter and shape factor and. Shape factor is an index brought out by Desale, which aims to describe how shape the grain is. Desale showed the effect of shape of particles on erosive wear in their experimental work. (19) They selected three different materials with the same size as erodent particles and determined their shape factor (SF) using the following relationship:

$$SF = \frac{4\pi A}{P^2} \quad (16)$$

In this definition, A is the projected area ( $\mu\text{m}^2$ ) and P is the overall perimeter ( $\mu\text{m}$ ) of the projection of a solid particle.

The grain in this model is generate with following method which aims to have the similar shape factor with the real grains. At first it will generate a sphere with the same diameter of the grain. Then this program will add some points on the edge of the sphere and link all these points to generate a grain with random shape. After the generation the program will calculate the shape factor of this grain to see if it is higher or lower than the required shape factor. If it is lower, the program will add more points on the surface of the sphere. On the other hand, if the shape factor is too high, the program will remove small amount of points from the surface to make the shape factor of generated grain lower. With several cycles the grains will be generated and follows the distribution we want to simulate the polishing process. The flow chart of this method is shown in Figure 9 and the simple result of one grain is shown in Figure 10.

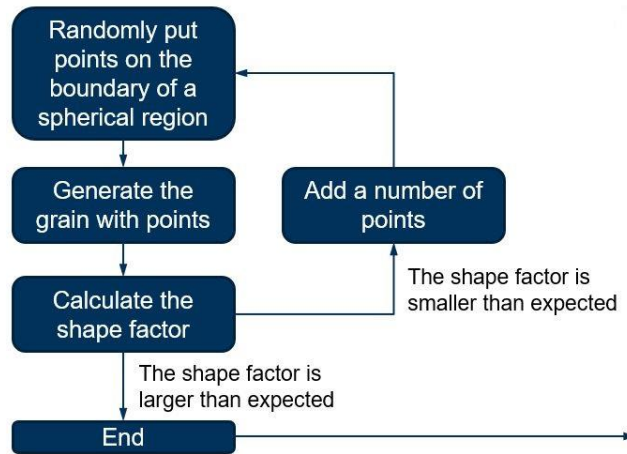

Figure 9 Chart Flow for the generation of grains

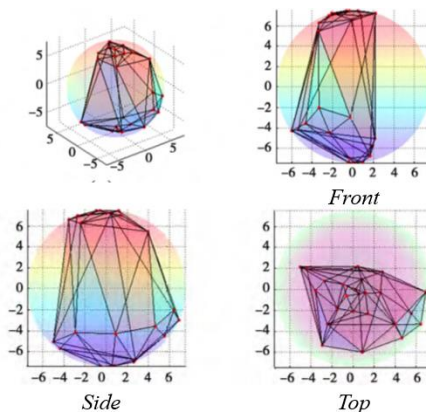

Figure 10 Example of grains generated

After the generation of grains, it is important to find out a method to describe how the grains are cutting on the surface with their unique shape. In Abrasive Flow Machining process, each grain is more like rolling on the surface and the depth of cutting is changing while different corner of the grain is pressing on the surface. From the help of Hertz contact equation, it is possible to derive the depth of cutting in the situation shown in Figure 9. From Figure 11 it is possible to find out the relation between cutting depth and radius of grain with equation (19). On the other hand, in Abrasive Flow Machining the Force in Hertz contact theory is influenced by the pressure in the fluid and contact area between grains and the surface of workpiece. The Hertz contact equation (5) can be derived to equation (19) for Abrasive Flow Machining process. With the help of equation (19) and equation (20), the link between depth and angle of corner can be derived into equation (21).

(17)

$$\frac{d \times \cot \alpha + d \times \cot(\pi - \alpha - \beta)}{2} = r$$

$$d = 1.55 \times \sqrt[3]{\frac{P^2 \cdot A^2}{2RE_m^2}} \quad (18)$$

$$d = \frac{32RE_m^2}{3.724P^2\pi^2[\cot\alpha - \cot(\alpha + \beta)]^4} \quad (19)$$

In these equations,  $R$  represents the radius of grains,  $E_m$  represents the Young's Modulus of workpiece,  $P$  represents the pressure from Fluid,  $\alpha$  represents the angle between the grain and the surface and  $\beta$  represents the angle of the corner which is pressing the surface now from the grain.

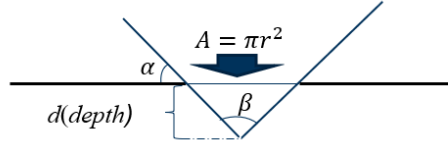

Figure 11 Schematic diagram of the calculation of cutting depth with one corner from the grains

After the generation of random grains, the angle of corners from each grain can be transferred into the cutting depth curve of each grain. The example of cutting depth with one grain is shown in Figure 12. With the angle of the corner and the distance between each corner from the grain, it is possible to simulate the generation of surface texture with the accumulate of cutting depth of each random generated grain and CFD module which provides the position of these grains during the whole cutting process.

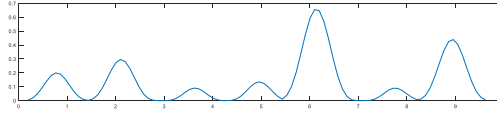

Figure 12 The cutting depth of one grain generated randomly

### 3.3 Simulation setup and results from validation trials

The manufacturing process parameters are listed in following table (Table 2), which uses equations to calculate different values when requested by the software.

Name	Expression	Name	Expression
Total Processing Volume (V)	60e-3 [m <sup>3</sup> ]	Processing time	V/Q
First Cycle Volume (V1)	2e-3 [m <sup>3</sup> ]	Inlet speed	Q/(pi/4*D <sup>2</sup> )
Back Pressure	3.23 [MPa]	Abrasion coefficient 1	20.75e-6 [(m/m <sup>3</sup> )/(1/s)]
Target Extrusion Pressure	6.1 [MPa]	Abrasion coefficient 2	8.36e-6 [(m/m <sup>3</sup> )/(1/s)]
Flowrate (Q)	16.4e-6 [m <sup>3</sup> /s]		

Table 2 Additional parameters and variables for simulation

Additionally, the simulation requires validation from the manufacturing data of further AFM trails. The AFM trials were conducted on a specially designed fixture which attempts to replicate the flow condition present in a segment part from an IBR; the installation is shown modelled in 3D CAD in Figure 7. The fully dimensioned 3d file of IBR is in the digital annex; the geometry was then converted through the addition of the cylinder geometry and Boolean operations into the fluid domain in Figure 13 and Figure 14.

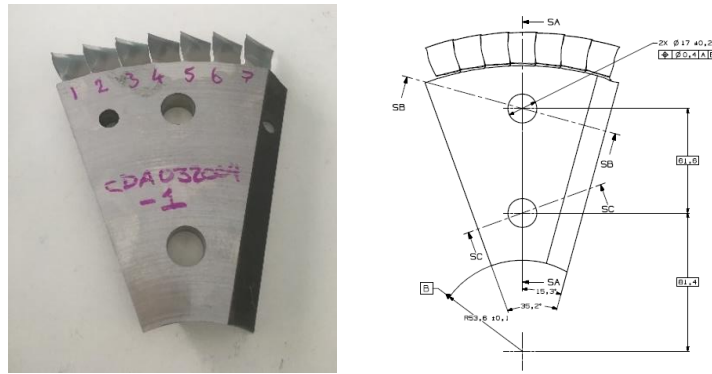

Figure 13 The test geometry for AFM trial and Fluid Domain used in simulation of AFM trial

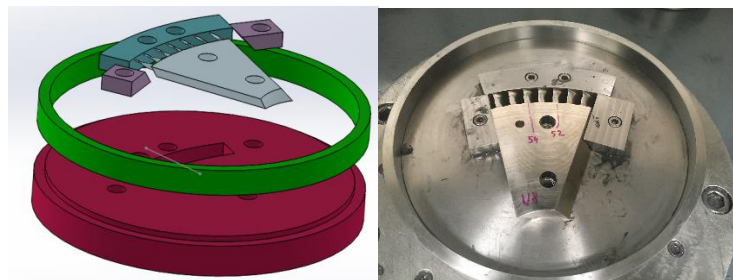

Figure 14 The geometry of fixture for the AFM trials

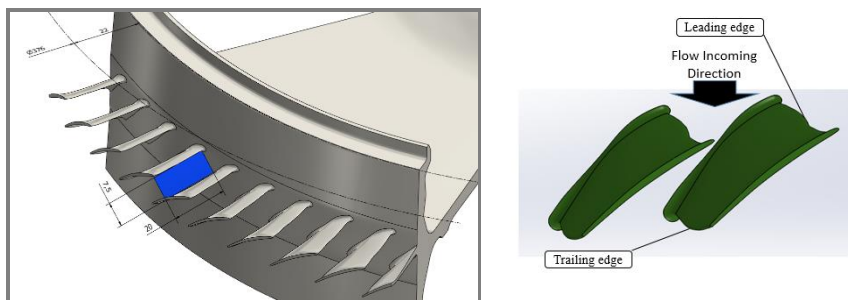

Figure 15 Representative flow restriction in AFM processing of IBRs

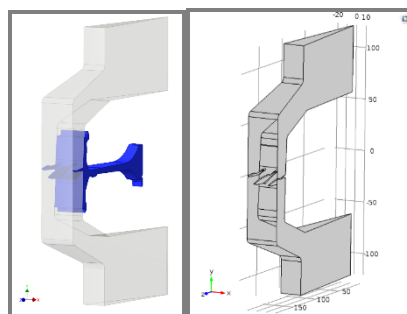

Figure 16 Fluid domain used in IBR geometry simulation (fluid domain in grey, while IBR section in blue colour)

#### 4.1 Simulation on material removal rate in the process

The experimental trials provide more data to test the simulation model against, the conditions for the coupon with the highest material removal were simulated first. To check if the abrasion coefficients obtained independently from these tests could be used to predict the process response, they were left unmodified for this simulation, the simulated shear rate field and the material removal results in thickness are shown in Figure 17.

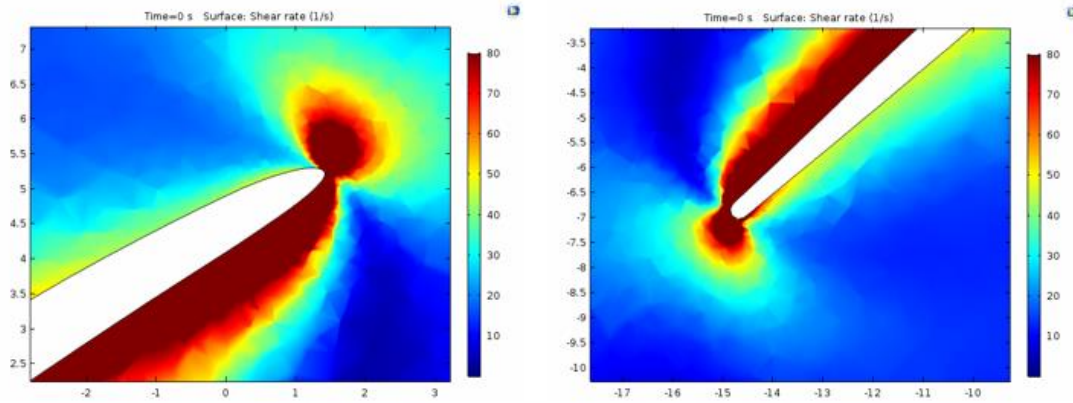

Figure 17 Simulation of material removal in abrasive flow machining (AFM) trials

The simulation could predict the resulting profile with reasonable accuracy; it is good enough that if such a prediction can be made before processing a single part, engineers could reduce the number of tests required when developing new components with the process.

#### 4.2 Simulation on profile accuracy control of blade leading/trailing edges

The rotors processed by AFM are commonly made of Inconel 718 or Ti-6Al-4V alloys. Currently, it is necessary to do some more investigation on calculating the abrasion constants for that material/media combination. The abrasion constants are derived from the real manufacturing data of IBR in ITP. Furthermore, the post AFM geometry is measured on a point-by-point basis with no actual digital profiles available to enable a comparison like what is shown in Figure 16, even if the profiles were routinely captured by the manufacturer, obtaining the information for academic research could prove very difficult due to the confidentiality policy.

In Figure 17 the predicted shear rate around the IBR profile suggests that material removal will not be uniform across along the profile. The location of the points with higher abrasion corresponds to the most repeated AFM principle: abrasion occurs at the point where media enters the point of higher restriction, with almost no abrasion present on the leading side of the low-pressure face (top) and the trailing side of the high-pressure face (bottom).



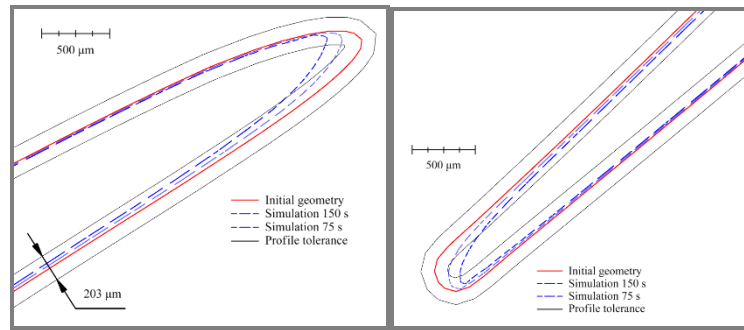

Figure 18 Simulated leading edge and trailing edge profiles

The results of simulation shine some light on the relative importance of the different input parameters involved in AFM. From the analysis of experimental trials, Volume (V) and Media (M) consistently created the largest difference in system response, with the volume being straightforward to modify, it should be the go-to parameter for tuning a process. Media is much harder to adjust as companies that use AFM for IBR processes will likely require prohibitively large batches for testing before switching media.

The development of the multiscale multi-physics modelling and simulation provides a convenient method for predicting the material removal of Abrasive Flow Machining and the optimise the production process of Abrasive Flow Machining.

#### 4.3 Simulation on profile accuracy control of the blade surface roughness

The Multiphysics simulation based on COMSOL provides a lot of information for the mechanical modelling which aims to predict the surface roughness and the generation of surface texture. It is possible to write a MATLAB code to enhance the function in COMSOL to provide the prediction of surface roughness.

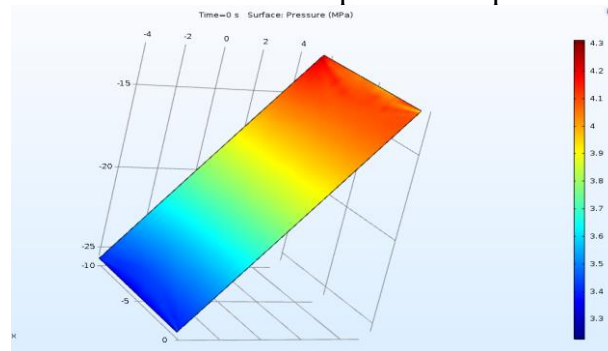

Figure 19. Pressure distribution of the fluid media on workpiece surface

The user defined MATLAB coding is mainly developed on the contribution of mechanism model and Monto Carlo method and the source data from the CFD simulation based on COMSOL. The pressure along the surface and velocity of fluid media is simulated by COMSOL and import into the mechanism model. After the generation of grains in the specific range of sharp factor, the grains are imported into the mechanism model and distributed into random position with initial velocity and pressure from CFD simulation to start the calculation of material removal by each grain. With the help of Monto Carlo simulation in MATLAB, these grains applied on the mechanism model simulation and contributes to the machining process by each of them.

In this MATLAB code the data about pressure and velocity distribution of fluid media along the workpiece surface is imported from the simulation based on COMSOL as described before. The example of pressure distribution of fluid media is shown in Figure 19. With the help of pressure and velocity, the mechanism

model can be applied to the random generated grains built from MATLAB to simulate the generation process of AFM along a small piece of workpiece surface as an example. With one single calculation, one line of wave will be generated with the result of mechanism model which represents the cutting depth through this whole line with one grain. With the help of Monto Carlo method, the calculation is done times after times randomly and the result will be accumulated in this plane.

After the calculation process of MATLAB code, it is necessary to bring the result back to the simulation in COMSOL for further calculation. As the result shown in Figure 20, the surface texture is somehow shown in MATLAB format. With the LiveLink for MATLAB and COMSOL these data can be communicated and updated at the same time. With this kind of help the simulation can stay at a better stage on the prediction accuracy on both surface roughness and material removal.

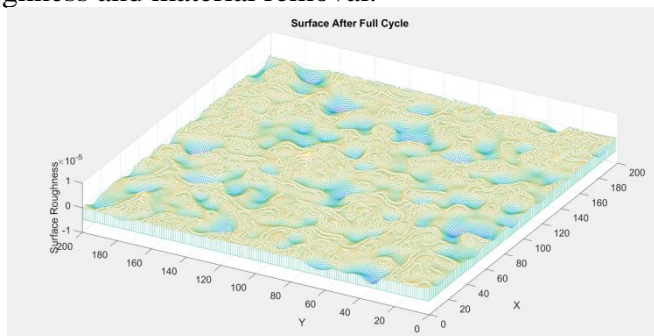

Figure 20. The prediction of surface roughness after the first AFM cycle

After the communication, the result of material removal will be sent back to COMSOL and the workpiece will change as the exact result from MATLAB to continue the simulation in the next cycle. It is also possible for COMSOL to read the surface roughness and profile accuracy through the connection between COMSOL and MATLAB which make this simulation more like a complete virtual AFM simulation.

## 5. Further discussion

From the case study, there is still some promotion can be approved on improving the performance of this virtual AFM manufacturing system. First is the part of the micro scale. At this stage, the simulation can only predict the material removal and edge profile on a macro level. It is necessary and significant for the simulation to work on the surface generation part on a micro level. In this way, the surface roughness and edge profile accuracy can be predicted, and it will be significant for further research and manufacturing. On the other hand, it is also useful to involve the heat transfer model in the simulation to provide the possible variation in temperature. The temperature will influence the material removal rate and surface quality. It will be meaningful to involve the heat by the process of simulation to increase the accuracy of prediction.

In the future, the multiscale multi-physics modelling and simulation can also provide the possibility for different types of industrial cases. It can be used in the simulation of many new non-traditional machining to provide the optimisation purpose. Many non-traditional machining cannot be simulated in the old methods because of the complicated machining process with more than three physical fields which influence each other during the whole process. With the help of multiscale multi-physics simulation, it can be more predictable and convenient for the manufacturer to adopt a new type of non-traditional machining. This point is significant in the manufacturing of aerofoil structures and components

## 6. Conclusions

The multiscale multi-physics modelling and simulation is a critical methodology in the future. It can

dramatically improve the feasibility and accuracy comparing to the model based on one single scale and physical field[21,22]. In this article, some models on different scales and physical areas are brought out for further discussion. In the next stage, some models with the coupling of different levels and physical fields are introduced and discussed. With some examples of combination among various scales and physical areas, the advantages of multiscale multi-physics modelling and simulation emerge. In the following the possibility of virtual manufacturing system based on multiscale multi-physics simulation is discussed. The virtual manufacturing system should include many different scales and physical fields to improve the accuracy. With the study case, a multiscale multi-physics modelling and simulation are used to optimise the industrial manufacturing process. The possibility and advantages of this method have been proved. It was indicated that a multiscale multi-physics modelling and simulation are very useful, and it is significant to improve more different coupling with different physical fields on various scales [23,24].

## References:

- [1] Attinger, S. and Koumoutsakos, P. (2004). *Multiscale Modelling and Simulation*. Berlin, Heidelberg: Springer Berlin Heidelberg.
- [2] Weinan, E. (2011). *Principles of Multiscale Modeling*. Cambridge University Press.
- [3] Tadmor, E. B., Ortiz, M. and Phillips, R. (1996). Quasi-continuum analysis of defects in solids. *Philosophical Magazine A*, 73(6), 1529-1563.
- [4] Bird, G. A. (1998). Recent advances and current challenges for DSMC. *Computers & Mathematics with Applications*, 35(1-2), 1-14.
- [5] Le Bris, C. and Lelievre, T. (2009). Multiscale modelling of complex fluids: a mathematical initiation. In *Multiscale Modeling and Simulation in Science* (pp. 49-137). Springer, Berlin, Heidelberg.
- [6] Le Bris, C. and Lelièvre, T. (2012). Micro-macro models for viscoelastic fluids: modelling, mathematics and numerics. *Science China Mathematics*, 55(2), 353-384.
- [7] Machado, M., Moreira, P., Flores, P. and Lankarani, H. M. (2012). Compliant contact force models in multibody dynamics: Evolution of the Hertz contact theory. *Mechanism and Machine Theory*, 53, 99-121.
- [8] Howard, M. and Cheng, K. (2013). An industrially feasible approach to process optimisation of abrasive flow machining and its implementation perspectives,” *Proc IMechE Part B: Journal Engineering Manufacture*, 228(11), 1419-1431.
- [9] Cheng, K., Shao, Y., Bodenhorst, R. and Jadvá, M. (2017). Modelling and simulation of material removal rates and profile accuracy control in abrasive flow machining of the IBR blade and experimental perspectives, *Transactions of the ASME: Journal of Manufacturing Science and Engineering*, 139(12), 121020.
- [10] Uhlmann, E., Schmiedel, C. and Wendler, J. (2015). CFD Simulation of Abrasive Flow Machining Process,” *Procedia CIRP*, 31, 209-214.
- [11] Schmitt, J. and Diebels, S. (2013). Simulation of the abrasive flow machining process,” *ZAMM- Journal of Applied Mathematics and Mechanics*, 93(2-3), 147-153.
- [12] Cheng, K., Shao, Y., Jadvá, M. and Bodenhorst, R. (2018). Development of the improved Preston equation for abrasive flow machining of aerofoil structures and components. *Proceedings of the Institution of Mechanical Engineers, Part J: Journal of Engineering Tribology*, 1350650118817694 (on-line published).
- [13] Howard, M. and Cheng, K. (2014). An integrated systematic investigation of the process variables on surface generation in abrasive flow machining of titanium alloy 6Al4V, *Proc IMechE Part B:*

*Journal Engineering Manufacture*, 228(11), 1419-1431.

- [14] Cheng, K. and Huo, D. (Editors, 2013). *Micro Cutting: Fundamentals and Applications*, John Wiley & Sons, Chichester, October 2013.
- [15] Rosen, J. Hannaford, B. and Richards, C. G. et al (2001). Markov modeling of minimally invasive surgery based on tool/tissue interaction and force/torque signatures for evaluating surgical skills, *IEEE Transactions on Biomedical Engineering*, 48(5), 579-591.
- [16] Jain, R, Jain V. and Dixit, P. (1999). Modeling of material removal and surface roughness in abrasive flow machining process,” *International Journal of Machine Tools & Manufacture*, 39, 1903-1923.
- [17] Shao, Y. and Cheng, K. (2019). Integrated modelling and analysis of micro-cutting mechanics with the precision surface generation in abrasive flow machining. *The International Journal of Advanced Manufacturing Technology*, 1-13 (on-line published).
- [18] Williams, R. E. (1993). Investigation of the abrasive flow machining process and development of a monitoring strategy using acoustic emission, PhD Thesis, University of Nebraska, Lincoln, 1993.
- [19] Desale, G. R., Gandhi, B. K. and Jain, S. C. (2006). Effect of erodent properties on erosion wear of ductile type materials. *Wear*, 261(7-8), 914-921.
- [20] Wan, S., Ang, Y. J. and Lim, G. C. (2014). Process modelling and CFD simulation of two-way abrasive flow machining,” *International Journal of Advanced Manufacturing Technologies*, 71(5), 1077-1086.
- [21] Kenda, J., Pusavec, F. and Kopac, J. (2014). Modeling and Energy Efficiency of Abrasive Flow Machining on Tooling Industry,” *2nd CIRP Conference on Surface Integrity (CSI)*, 13, 13-18.
- [22] Sun, X. Z. and Cheng, K. (2010). Multiscale simulation of the nanometric cutting process, *International Journal of Advanced Manufacturing Technology*, 47, 891-901.
- [23] Fan, J. (2011). *Multiscale Analysis of Deformation and Failure of Materials (Vol. 5)*. John Wiley & Sons.
- [24] Liu, W. K., Karpov, E. G. and Park, H. S. (2006). *Nano Mechanics and Materials: Theory, Multiscale Methods and Applications*. John Wiley & Sons.