

How home cooking methods and appliances affect the GHG emissions of food

Angelina Frankowska^{1}, Ximena Schmidt Rivera², Sarah Bridle¹, Alana Marielle Rodrigues Galdino Kluczkowski¹, Jacqueline Tereza da Silva^{3,4}, Carla Adriano Martins¹, Fernanda Rauber³, Renata Bertazzi Levy³, Joanne Cook¹, Christian Reynolds^{5,6}*

Abstract

Food is widely acknowledged as a significant contributor to climate change. Yet, estimates of food-related greenhouse gas emissions frequently consider supply chain stages only up to farm gate or regional distribution centres. Here, we estimate greenhouse gas emissions associated with different cooking methods and appliances in the UK. Data on current cooking practices were collected through a survey with more than 700 respondents. Results reveal that home cooking accounts for as much as 61% of total emissions associated with specific foods, and that this can be substantially reduced through alternative, readily available cooking practices.

Main

The contribution of home cooking to climate change is rarely assessed since data on household cooking practices are scarce. Yet, understanding climate change impacts of different food items from cradle to grave is vital for effectively reducing GHG emissions.

When whole life cycles of food products are taken into account, food is estimated to emit up to 37% of global GHG emissions¹. Most studies, however, estimate the climate change impact of food up to the retail/purchase stages of the food supply chain, thus excluding consumption (here defined as food preparation and cooking). Yet, the consumption of meat and vegetables can contribute up to 20% and 36% of total product emissions, respectively, when recipe recommendations of major cooking methods are followed^{2,3}. Cooking food from scratch at home can result in lower overall GHG emissions compared to consuming ready-made meals⁴.

Previous studies have indicated that GHG emissions from home cooking can be reduced by minimizing cooking time and appliance use. Such a reduction could reach 86% in the case of pasta⁵ and the equivalent of 18-55% less energy use in the case of roast beef and Yorkshire puddings⁶. However, little is known about actual cooking practices for different foods in households. Previously recorded cooking practices adopted by university students could indicate how to reduce GHG emissions due to unsustainable cooking⁷, but are not representative of general consumption patterns across the population.

Here, we assess the impact of home cooking based on actual cooking practices and preferences rather than solely on recipe recommendations. We first report the results of a UK-wide survey conducted to collect data on cooking practices considering various foods, appliances and cooking times. Then, we compare different cooking methods with respect to their GHG emissions and estimate the contribution of cooking to food products' overall impact on climate change. Based on these results, we identify the least and most sustainable cooking techniques as well as opportunities to reduce their GHG footprint. Unsustainable cooking practices such as prolonged heating-up of the oven or overcooking of food, as well as not using energy-efficient appliances may be factors which increase GHG emissions unnecessarily. Addressing these issues can help raise awareness about the contribution of cooking to climate change and how unsustainable cooking practices can exacerbate the problem.

Cooking practices in the UK

Our survey revealed that on average cooking accounts for 6-61% of the total GHG emission impacts for a given food (Fig. 1a). In the particular case of vegetables (namely potatoes, carrots, cabbage, cauliflower and onions), cooking accounts for up to 61% of total emissions. In the case of meat and fish, it represents 8-27% of their total emissions.

Considering foods that are ready to eat, the toasting of bread contributes to 13% of the total emissions released (Fig. 1). For semi or pre-cooked foods, such as tofu and quorn, cooking accounts for up to 42% of GHGs. Canned baked beans, which are ready to eat after being heated up, represent 6% of their total emissions. Other types of canned pulses (beans or chickpeas) cooked with other ingredients in various dishes represent 28% of total GHG emissions.

Cooking meat accounts for the highest overall emissions across the various foods in the UK. This is due to the long cooking times (>60 minutes) of oven roasting, which consumes the most energy among the different appliance types (Fig. 2f-g, Supplementary fig 1p-q, Supplementary table 1&2). However, while lamb and beef cause the highest total GHGe by far, cooking impacts are mostly less than 11% of total GHG emissions. When compared to the pre-cooking stage ($60 \text{ kgCO}_2\text{e/kg}_{\text{cooked}}$), cooking related emissions (up to $6.9 \text{ kgCO}_2\text{e/kg}_{\text{cooked}}$) are negligible. This suggests that reducing the consumption of lamb and beef is more important than changing the cooking method. Instead consuming pulses as a rich protein source generate lower GHG emissions. For instance, frozen and canned pulses reduce emissions by up to 29 times and nine-fold compared to beef/lamb and pork/chicken meat, respectively per kg of cooked food (Fig. 1). Pulses also perform better considering the protein content reducing GHG emissions by about 40% for chicken/pork and up to six times for beef/lamb (Supplementary fig. 2). Furthermore, beef emissions are highest based on the calories among the different foods (Supplementary fig 2).

Figure 1 | Total greenhouse gas emissions of various food items. Each bar indicates the share of a given item's climate change impact associated with pre-consumption (white) and cooking (blue). Supplementary figure 2 shows the results normalised by protein and calorie content. Percentages in parentheses show the percentage cooking impact.

Cooking methods' GHG emissions [

The amount of GHG emissions differs considerably among the various cooking methods, as shown in Fig. 2 for some selected foods and in Supplementary fig. 1 for the remainder. Cooking emissions can be at least halved (in the case of toast) and reduced up to 16-fold (in the case of tofu/Quorn) by changing the cooking method applied.

Considering the most common cooking appliances, ovens are the least sustainable due to comparatively long cooking time and high energy demand, while microwaves have the lowest overall impact. For vegetables, roasting in the oven makes up for 53-78% of the total impact (Fig. 2b, Supplementary fig. 1a-d). Due to the differences in taste, texture and aroma resulting from oven and microwave preparation, the comparison of these two methods may be considered misleading. Still, pre-cooking some types of food in a microwave would decrease the time required in the oven without substantially affecting sensorial properties – ultimately resulting in lower GHG emissions.

The impacts of cooking in a microwave, steaming and boiling are comparable for reheating, defrosting and preparing vegetables, fruits, eggs and fish. Using the stovetop for these foods and practices leads to the highest impact among appliances since energy demand and cooking time are higher due to energy losses and the time it takes to reach cooking temperatures (Supplementary table 1). By contrast, microwaving reduces GHG emissions by 41-78% compared to boiling and steaming. Electric steaming has the lowest impact for vegetables (Fig. 2b, Supplementary fig. 1a,d,g).

Using an electric grill may be a good alternative to toasting or grilling in the oven since an electric grill consumes half of the energy. For instance, grilling chicken in an electric grill releases 73% less GHG emissions than grilling in an oven. Electric grilling corresponds to 9% of the impact coming from the consumption stage, as opposed to 27% for oven grilling (Fig. 2f).

Cooking under pressure is an efficient way of cooking meat, pulses, potatoes and vegetables since the cooking time is substantially shortened. Using an electric pressure cooker as opposed to one that operates on the stovetop could further reduce emissions, since 50% less energy is required. *Sous-vide* cooking, also known as low temperature long time cooking, involves placing food inside a vacuumed plastic pouch/bag and submerging this in a heated water bath for several hours until it reaches a desired internal core temperature; this method also has a low GHG emission footprint, though other environmental issues due to the plastic use must be considered⁶. However, *sous-vide* cooking is not represented in the survey and pressure cooking is hardly used in the UK. Only 2% of the participants prepared beef under pressure, and they reported cooking meat for longer than recommended by recipes. Although slow cooking is the most energy efficient appliance, generating low GHG emissions despite the long cooking times (see Supplementary Table 1), it is not used much in the UK either.

Such limited use and unrealistically short cooking times reported for slow cooking in the survey suggest that this method is perhaps confused and indicates the need for more research on less popular cooking methods (See Supplementary text 1).

In summary, our results underscore the importance of analysing cooking practices for mitigating climate change, particularly when consumption is a significant contributor to the overall impact of food. Cooking time is instrumental in determining food based-GHG emissions and is a potential opportunity for emission reduction. Cooking's GHG footprint can be reduced substantially by changing the cooking method and appliance. Different cooking methods can complement each other to shorten the total usage of unsustainable appliances, thereby reducing GHG emissions. Using cleaner energy sources will also lower current cooking emission levels; the increasing use of renewables has the potential to decarbonize the electricity grid, allowing the use of electric appliances or biogas for ovens and hobs, for example [add ref]. Our finding that low-emission cooking methods (i.e. pressure cooking and slow cooking) are not commonly used in the UK reveals potential for improvements in home cooking habits. Finally, we note that our analysis has focused on the UK cooking culture, but similar analyses are needed to understand the climate change impact of different cooking cultures around the world.

Figure 2 | Greenhouse gas emissions of various cooking methods when applied to different food items in relation to their cooking times. Each of the panels (a-g) shows, for a given food and per relevant cooking method, the cooking time, the share of total GHG emissions represented by cooking, as well as the amount of GHG emissions per amount of food. Relevant cooking methods are those identified through the survey as applied to each of the food items.

Methods

A survey was used to capture data on cooking habits in households including the cooking time and method (https://osf.io/t7h4x/?view_only=83a37df45ab747609259575aa093ac01). The survey has been conducted across the UK, considering the 30 food items most consumed nationally. Data were collected from 765 participants (n=765) who were asked to specify cooking method, appliance and time for 30 foods of a given portion size. The data were cleaned by applying sigma clipping to remove outliers. Furthermore, a cut-off criterion of n>10 participants was considered for each cooking method to be accounted for in the evaluation. Data cleaning resulted in 684≤n≤759 depending on the type of food and cooking method.

Eleven different cooking methods have been assessed using ten appliances. We assumed that stovetops are used for shallow frying, while boiling can be done on the stovetop or in the microwave. Roasting, baking, broiling, grilling and toasting are conducted in the oven. Additionally, an electric grill and toaster might be considered for grilling and toasting bread, respectively. We also assumed that *sous vide*, electric grill, slow cooker, microwave and toaster are all electric appliances; pressure cooking, steaming and deep frying could be conducted either in specialized electric appliances (i.e. pressure cooker, steamer and deep fryer) or on the stovetop – assuming equal share under each of the two options due to lack of data. Further assumptions include toasting bread in a toaster or in the oven, with the former representing 70% of the cases as most UK households own a toaster⁸. Ovens in the UK

operate primarily with electricity (70%) and one-third of them is supplied with natural gas; stovetops, on the contrary, are mostly fuelled by natural gas (62%) and the remainder (38%) operates with electricity⁹.

We built a database of energy consumption of household appliances based on the energy demand of the various appliances declared by the manufacturer. Greenhouse gas emissions were calculated based on the energy demand of the cooking method, the median cooking time drawn from the survey and the carbon emission factors of the UK national electricity mix and natural gas for the year 2019¹⁰.

Data on pre-cooking GHG emissions for the different foods were taken from existing literature and aggregated with the cooking impacts estimated from the survey^{2,5,11-20}. The share of total impact represented by each cooking method was also based on the survey.

Supplementary table 1 and 2 contain the assumptions described above as well as a list of the different food items, portion sizes, median cooking times, pre-consumption data sources, share of cooking methods and the conversion factors of raw to cooked foods for the former (and the average energy consumption of the different cooking appliances for the latter). The questionnaire can be found in Supplementary table 3. Results of raw food, and normalised by protein and calorie content are displayed in Supplementary fig 2 and 3. Information about typical methods used by respondents can be found in Supplementary figure 4.

Data availability

The data that support the findings of this study are available in [repository name] with the identifier(s) [data DOI(s)]

Code availability

References

1. Rosenzweig, C. *et al.* Climate change responses benefit from a global food system approach. *Nat. Food* **1**, 94–97 (2020).
2. Frankowska, A., Jeswani, H. K. & Azapagic, A. Environmental impacts of vegetables consumption in the UK. *Sci. Total Environ.* **682**, 80–105 (2019)
3. Frankowska, A. Environmental impacts on the food-energy-water nexus in the UK food sector. (University of Manchester, 2019).
4. Schmidt Rivera, X. C., Espinoza Orias, N. & Azapagic, A. Life cycle environmental impacts of convenience food: Comparison of ready and home-made meals. *J. Clean. Prod.* **73**, 294–309 (2014).
5. Cimini, A. & Moresi, M. Energy efficiency and carbon footprint of home pasta cooking appliances. *J. Food Eng.* **204**, 8–17 (2017).
6. Reynolds, C. J. Energy embodied in household cookery: The missing part of a sustainable food system? Part 2: A life cycle assessment of roast beef and Yorkshire pudding. *Energy Procedia* **123**, 228–234 (2017).

7. Clear, A. K., Hazas, M., Morley, J., Friday, A. & Bates, O. Domestic food and sustainable design: A study of university student cooking and its impacts. in *Conference on Human Factors in Computing Systems - Proceedings 2447–2456* (2013). doi:10.1145/2470654.2481339
8. Statista Global Consumer Survey. Which of the following household appliances does your household own? *Global Consumer Survey 2019* (2019). Available at: <https://www.statista.com/forecasts/997843/household-appliances-ownership-in-the-uk>.
9. DECC. Domestic appliances, cooking & cooling equipment. *Energy Follow-Up Survey 2011, Report 9*, 53 (2011). https://assets.publishing.service.gov.uk/government/uploads/system/uploads/attachment_data/file/274778/9_Domestic_appliances__cooking_and_cooling_equipment.pdf10. DBEIS. Annual conversion factor publications. (2019). <https://www.gov.uk/government/publications/greenhouse-gas-reporting-conversion-factors-201911>. Recchia, L., Cappelli, A., Cini, E., Pegna, F. G. & Boncinelli, P. Environmental sustainability of pasta production chains: An integrated approach for comparing local and global chains. *Resources* **8**, (2019).
12. Poore, J. & Nemecek, T. Reducing food's environmental impacts through producers and consumers. *Science (80-.)* **360**, 987–992 (2018)
13. Jeswani, H., Burkinshaw, R. & Azapagic, A. Environmental sustainability issues in the food-energy-water nexus: Breakfast cereals and snacks. *Sustain. Prod. Consum.* **2**, 1–12 (2015) doi:10.1016/j.spc.2015.08.001
14. Robinson, B., Winans, K., Kendall, A., Dlott, J. & Dlott, F. A life cycle assessment of Agaricus bisporus mushroom production in the USA. *Int. J. Life Cycle Assess.* **24**, 456–467 (2019).
15. Usubharatana, P. & Phungrassami, H. Life cycle assessment of the straw mushroom production. *Appl. Ecol. Environ. Res.* **14**, 367–382 (2016)
16. Gunady, M. G. A., Biswas, W., Solah, V. A. & James, A. P. Evaluating the global warming potential of the fresh produce supply chain for strawberries, romaine/cos lettuces (*Lactuca sativa*), and button mushrooms (*Agaricus bisporus*) in Western Australia using life cycle assessment (LCA). *J. Clean. Prod.* **28**, 81–87 (2012).
17. Blonk, H., Kool, A., Luske, B., Ponsioen, T. & Scholten, J. Methodology for assessing carbon footprints of horticultural products horticultural products. (2010).
18. Frankowska, A., Jeswani, H. K. & Azapagic, A. Life cycle environmental impacts of fruits consumption in the UK. *J. Environ. Manage.* **248**, 109111 (2019)
19. Noya, I. *et al.* Carbon and water footprint of pork supply chain in Catalonia: From feed to final products. *J. Environ. Manage.* **171**, 133–143 (2016).
20. Quom. Carbon footprinting emissions report. (2019).

Acknowledgments

This research activity was funded through multiple research grants from Research Councils UK, the University of Manchester, the University of Sheffield, the STFC Food Network+ and the HEFCE Catalyst-funded N8 AgriFood Resilience Programme with matched funding from the N8 group of Universities. Specific named projects that funded this research include the STFC GCRF funded project “Trends in greenhouse gas emissions from Brazilian foods using GGDOT” (ST/S003320/1), the STFC funded project “Piloting Zooniverse for food, health and sustainability citizen science” (ST/T001410/1), and the STFC Food Network+ Awarded Scoping Project “Piloting Zooniverse to help us understand citizen food perceptions”. Funding was also supplied from Research England via the University of Sheffield QR Strategic Priorities Fund projects “Cooking as part of a Sustainable Food System – creating an wider

evidence base for policy makers”, and “Food based citizen science in the UK as a policy tool”. This research project arose from the N8 AgriFood-funded project “Greenhouse Gas and Dietary choices Open-source Toolkit (GGDOT) hacknights.’ Ximena Schmidt Rivera was supported through Brunel University internal Research England GCRF QR Fund. Alana Kluczkovski and Carla Adriano Martins were supported through The University of Manchester GCRF QR Visiting Researcher Fellowship.

Author information

Affiliations

¹ Department of Physics and Astronomy, University of Manchester, Oxford Road, Manchester, M13 9PL United Kingdom

² Equitable Development and Resilience research group, College of Engineering, Design and Physical Science, Brunel University London, London, United Kingdom

³ School of Medicine, University of São Paulo. Av. Dr. Arnaldo, 455 - Pacaembu, São Paulo, Brasil. Zip code:01246903

⁴ HCor Research Institute. Rua Abílio Soares, 250 12 andar, São Paulo, Brasil. Zip code: 04005-000

⁵ Department of Geography, University of Sheffield, Sheffield,S3 7ND, United Kingdom

⁶ Centre for Food Policy, City University of London, Myddelton Street Building, City, University of London, Myddelton Street, EC1R 1UW, London, United Kingdom

Contributions [

AF XSR SB RBL CR conceptualised the study; AF provided data analysis, AF XSR SB AK JTS CAM FR RBL CR developed the Methodology, AF ran the Modelling, AF conducted Formal analysis AF and JC developed the visualizations and figures. AF provided the Writing (original draft) with XSR, SB, AK, JTS, CAM, FR, RL, JC, and CR providing additional Writing, review and editing. XSR and CR developed the survey, conducted the data collection and data linking (as part of a wider team), XSR, SB, JTS RL and CR provided Funding acquisition, XSR, SB and CR provided Project administration; and team supervision.

Corresponding author:

Angelina Frankowska | e-mail: angelina.frankowski@manchester.ac.uk

Ethics declaration

Written informed consent was obtained from the 765 participants of the study before assessing the survey. Ethics approved 9th of March 2020 (University of Sheffield Geography Department, Application #033516)

Competing interests

The authors declare no competing interests.

Supplementary information

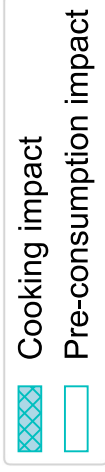
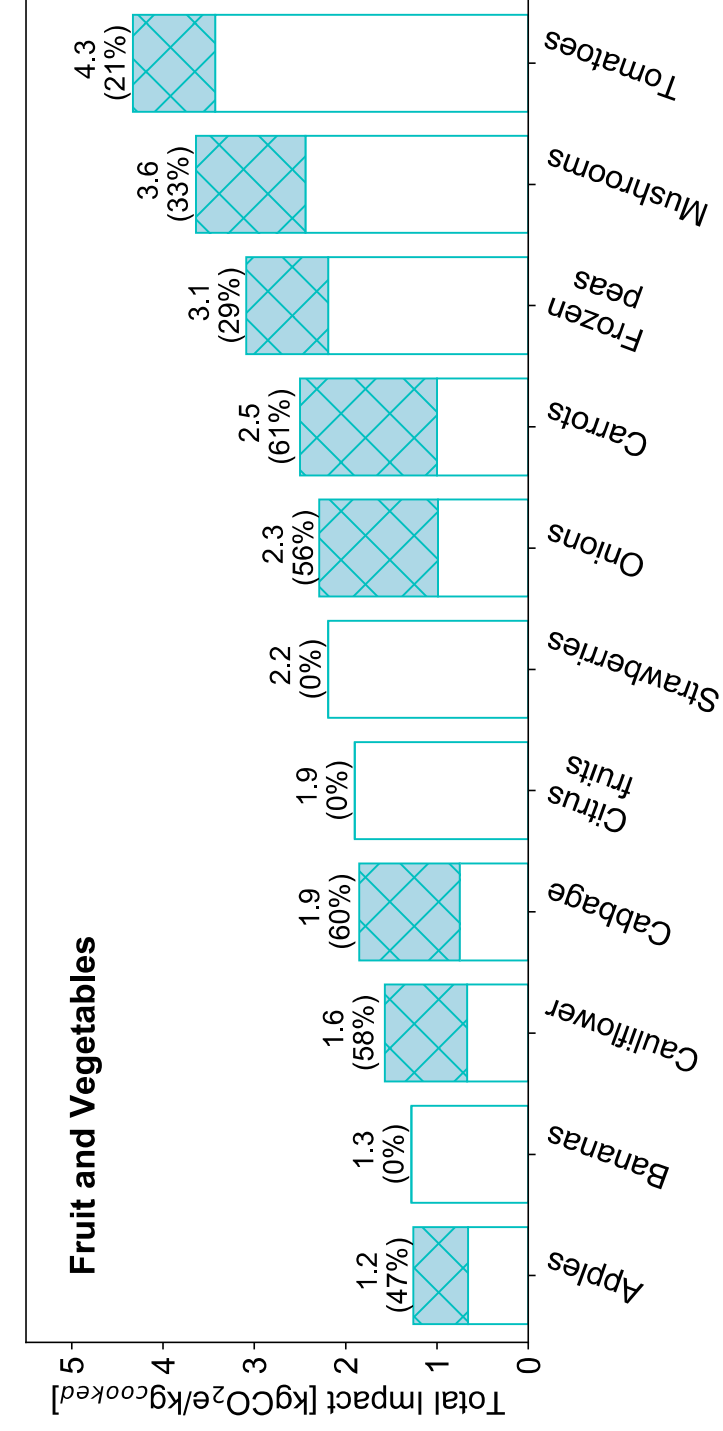
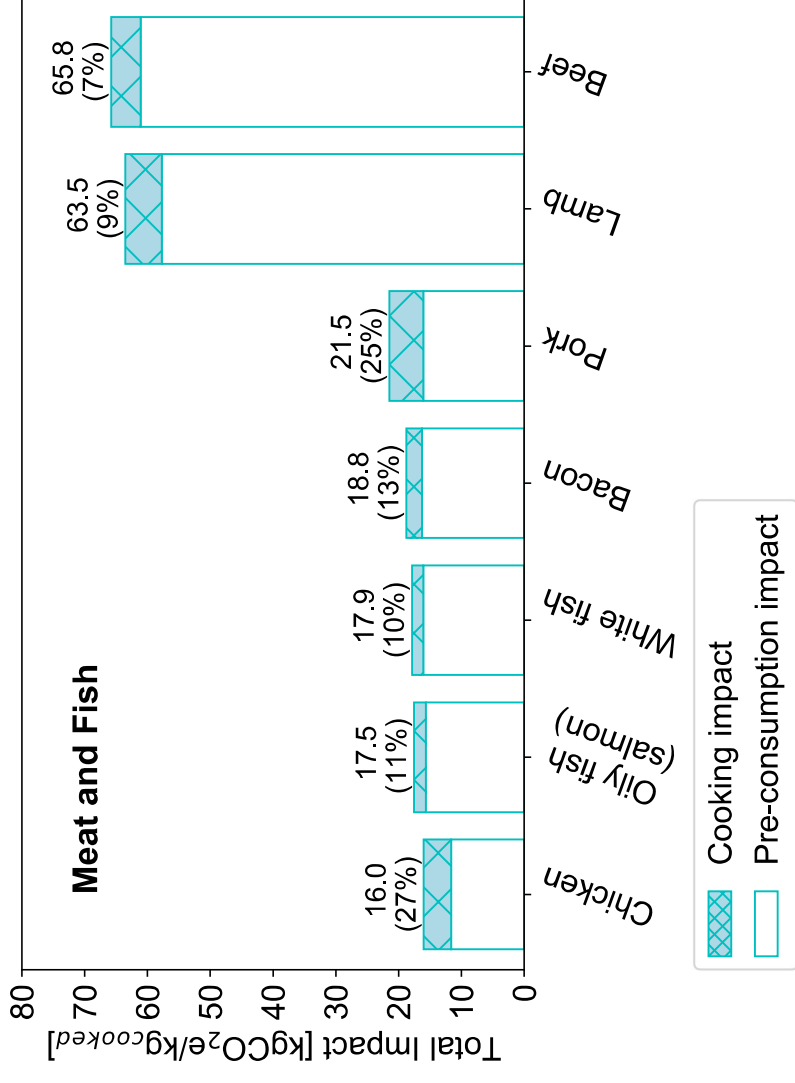
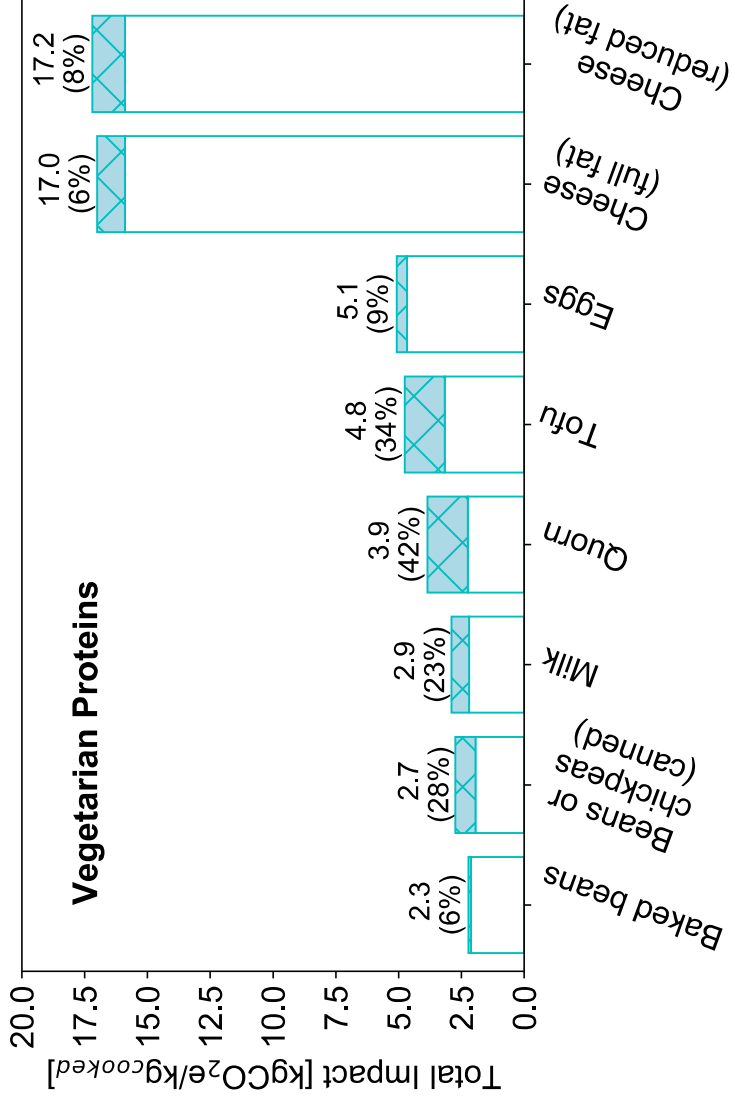
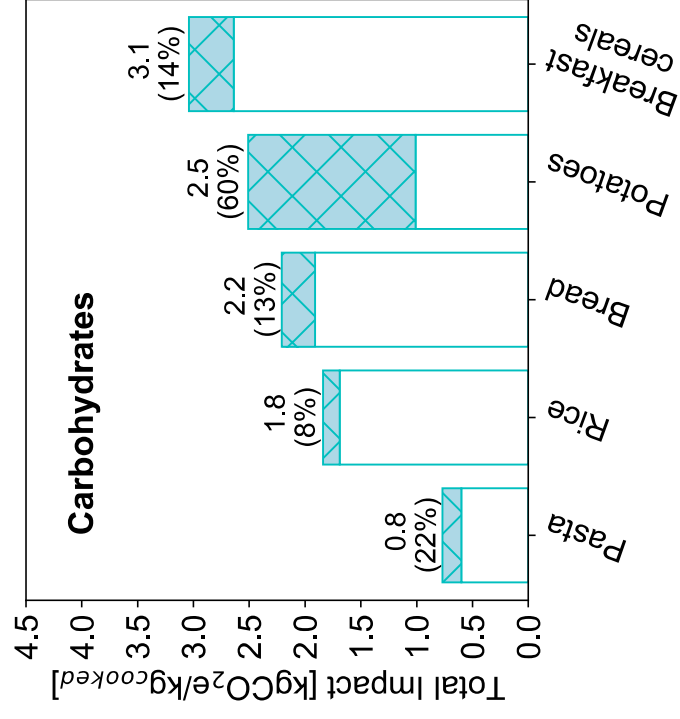

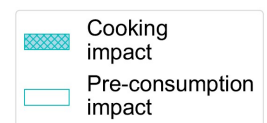
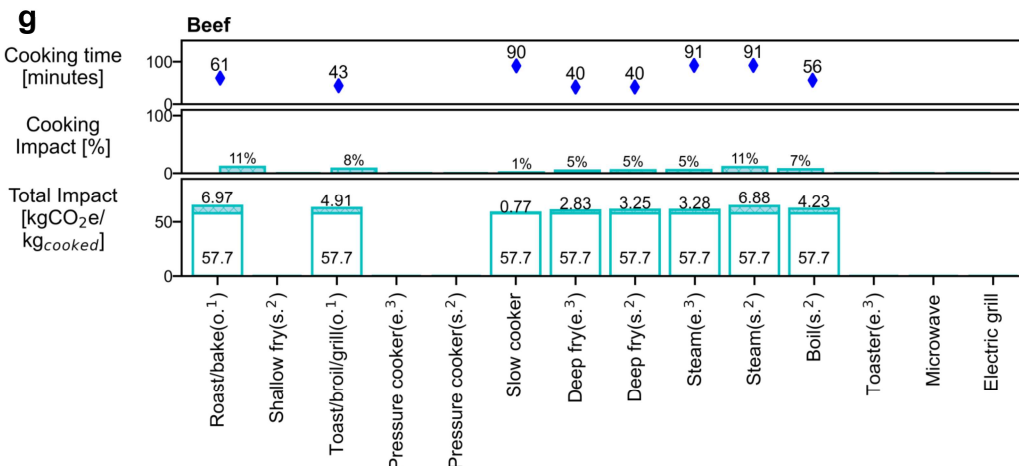
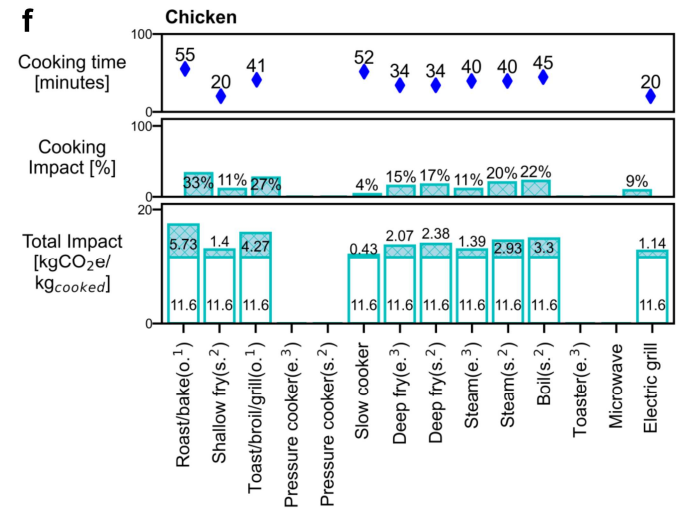
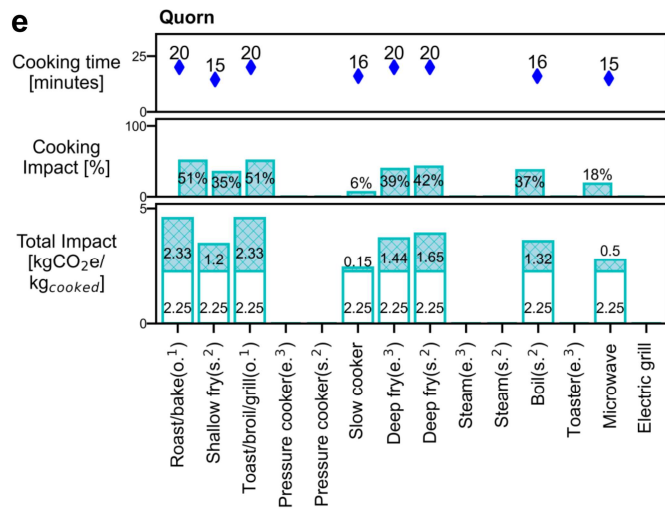
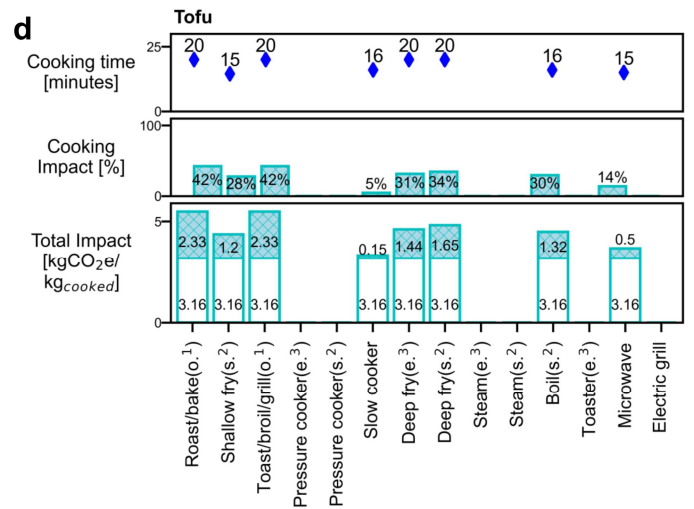
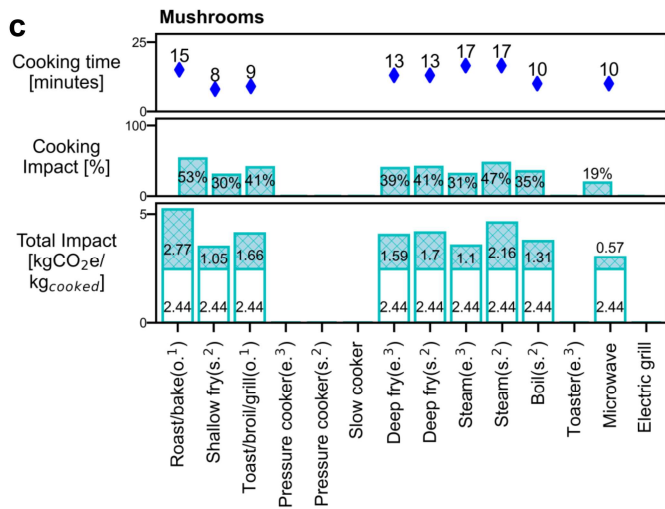
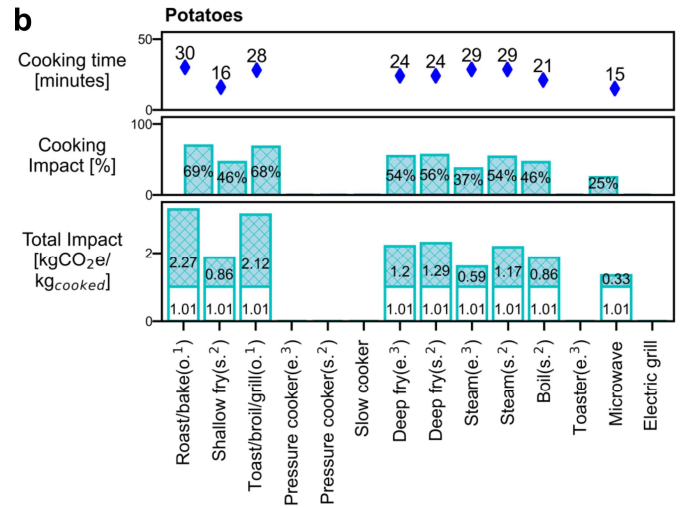
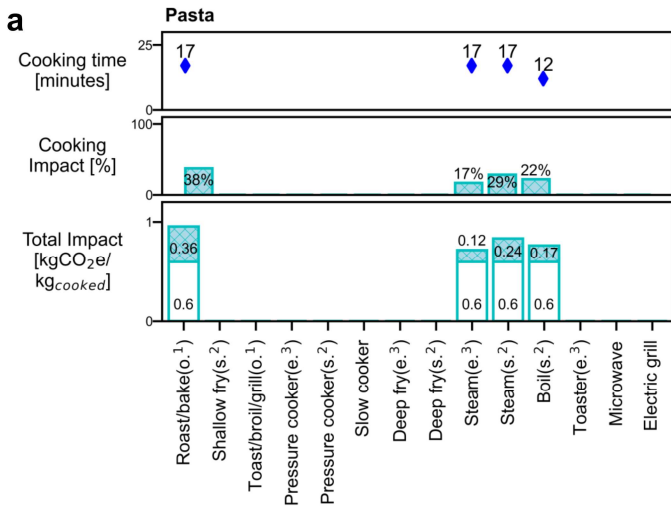

Supplementary data for

How home cooking methods and appliances affect the GHG emissions of food

Angelina Frankowska^{1*}, Ximena Schmidt Rivera², Sarah Bridle¹, Alana Marielle Rodrigues Galdino Kluczkowski¹, Jacqueline Tereza da Silva^{3,4}, Carla Adriano Martins¹, Fernanda Rauber⁵, Renata Bertazzi Levy³, Joanne Cook¹, Christian Reynolds^{5,6*}

¹Department of Physics and Astronomy, University of Manchester, Manchester, United Kingdom

² Institute of Energy Futures, College of Engineering, Design and Physical Science, Brunel University London, London, United Kingdom

³ School of Medicine, University of São Paulo, São Paulo, Brazil

⁴ HCor Research Institute, São Paulo, Brazil

⁵ Department of Geography, University of Sheffield, Sheffield, United Kingdom

⁶ Centre for Food Policy, City University, London, United Kingdom

Summary of Supplementary data in this deposit

Supplementary text 1 Supplementary Information - Notes on Slow Cooking

Supplementary figure 1: Greenhouse gas emissions of various cooking methods for different foods in relation to their cooking times by kg of cooked food?

Supplementary figure 2: Total greenhouse gas emissions of various food items including the share of cooking contribution to the total impact by protein (g) (Supplementary figure 2A) and calorie (kcal) (Supplementary figure 2B) content in cooked food.

Supplementary figure 3: Results presented as “raw” (uncooked).

Supplementary figure S4: Percentage of respondents reporting typical cooking method

Supplementary table 1: Summary of cooking appliances database based on manufacturer information

Supplementary table 2: Survey and literature data. Share of cooking methods does not consider the two categories “I do not eat this food” and “I typically eat this food as purchased without further cooking”.

Supplementary text 2: Questionnaire from Survey

References

Note additional attached supplementary data not in this file includes a spreadsheet that reports the cooking impacts per kg cook, called “Nature_food_figures_raw_and_cooked.xlsx”

Supplementary Text 1 - Notes on Slow Cooking

Slow cooking was present in the answers of the survey once sigma-clipping and our cut-off criterium had been applied. In many plant or carbohydrate foods 1-2% of respondents selected slow cooking as their typical cooking method (beans and chickpeas were an exception with 4%). While animal foods had higher rates of slow cooking as the typical cooking method (chicken, 4%; pork 6%, lamb 7%, beef 9%). However, the cooking times stated by a number of respondents are different from times discussed in recipes for this cooking technique. We have included this methodology to remain consistent and transparent with our data collection and processing methods. It is worth noting that as the survey asked for the *typical* cooking method and duration for when the survey respondent cooks a specific (*average*) portion size of the various foods. This may have led to this timing error occurring. With respondents trying to scale the cooking time to fit the smaller portion size for a slow cooker - a cooking method suited to larger portions and batch cooking. In future surveys we now have deployed asking for the typical serving size, and the typical number of servings cooked to mitigate this variation (and further understand the impact of economies of scale and batch cooking in reducing carbon footprints).

A second variation that impacts upon the cooking time, is the lack of specificity in the types of foods in the survey leading to a range of cooking times reported. For instance, In our survey we asked for the typical cooking method and time for the respondents typical consumption of an average portion of "beef"; this means that the type and quality of beef eaten by the respondent (e.g. cut of meat or mince) was never reported to the survey. As different cuts of meat have different cooking times (and cooking methods); the spectrum of cooking times reported could be due (in part) to the preferences of the respondents. This is both a limitation of our pilot survey, and a further avenue for future research.

Supplementary figure 1: Greenhouse gas emissions of various cooking methods for different foods in relation to their cooking times by kg of cooked food?

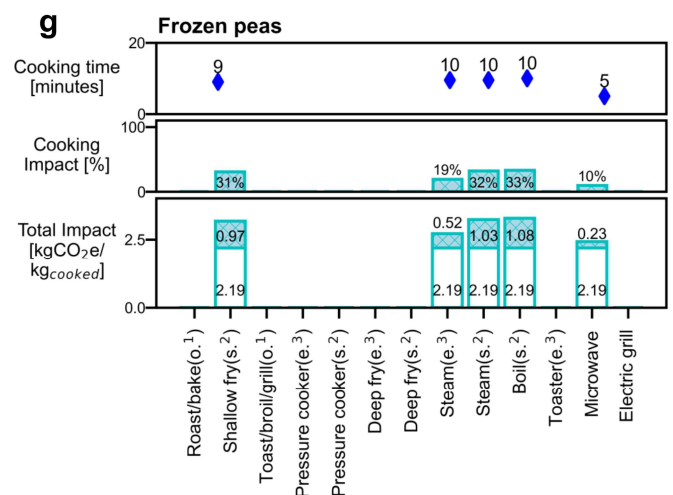
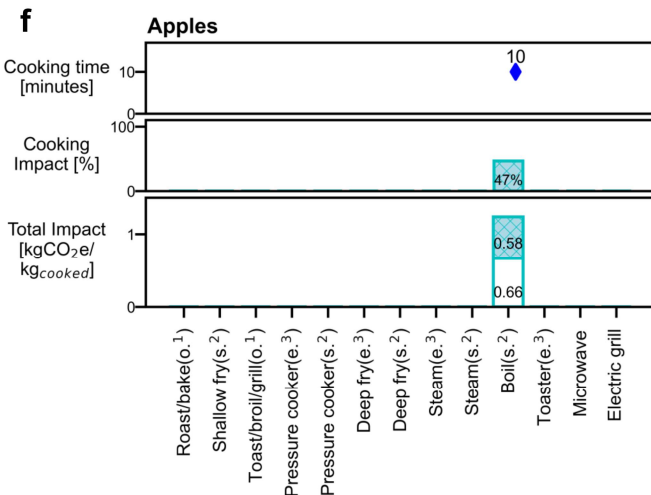
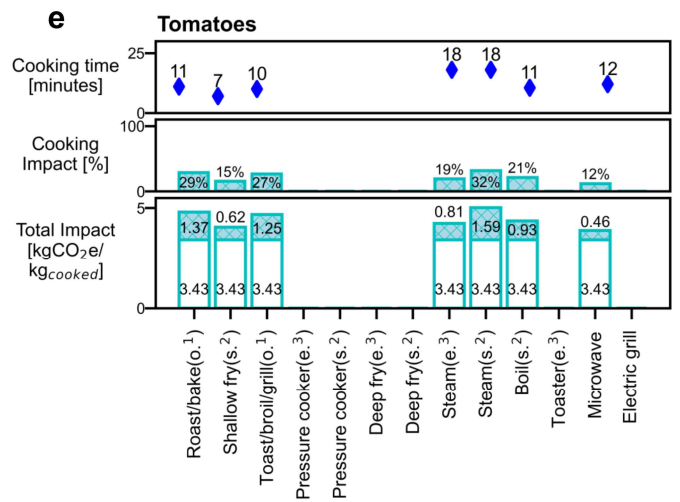
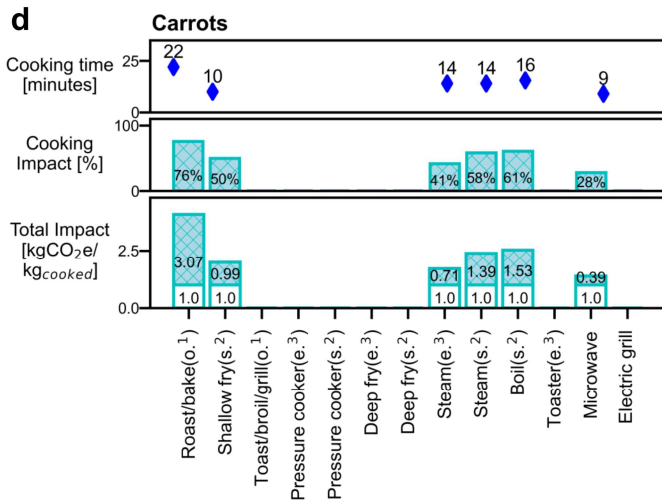
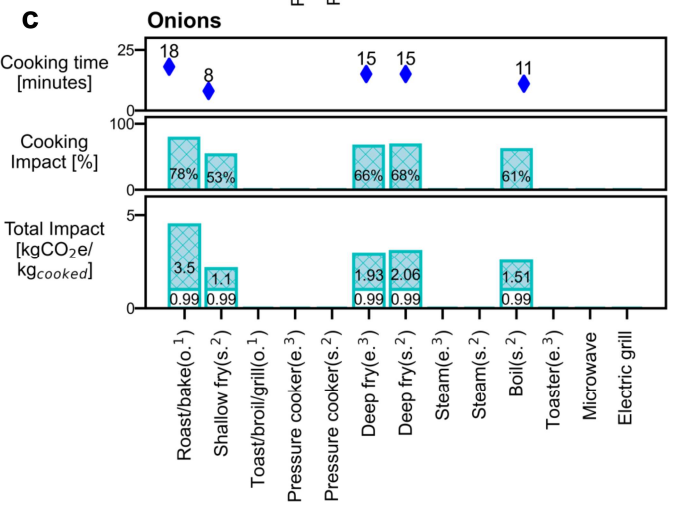
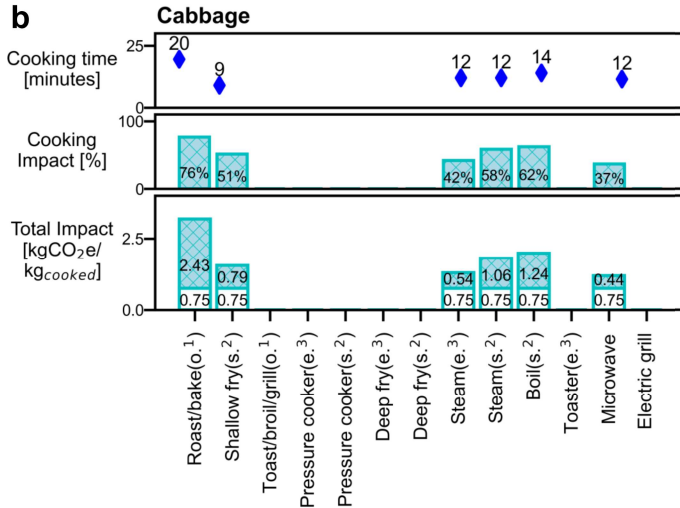
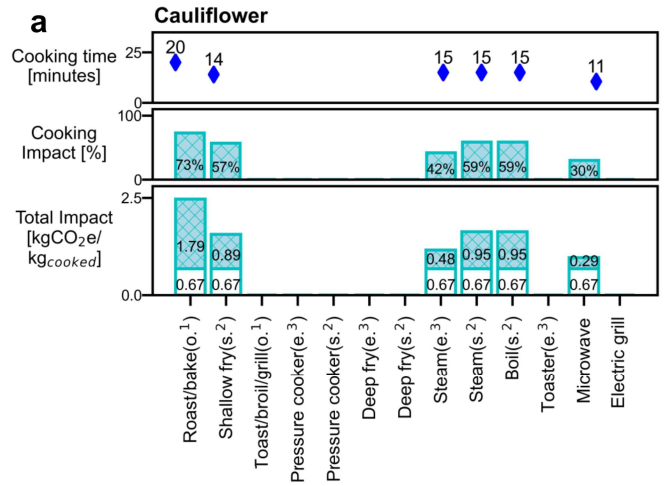
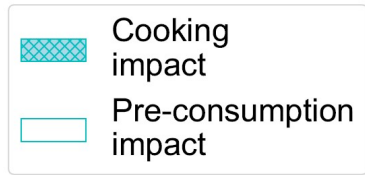

Supplementary figure 1: Greenhouse gas emissions of various cooking methods for different foods in relation to their cooking times by kg of cooked food? (continued)

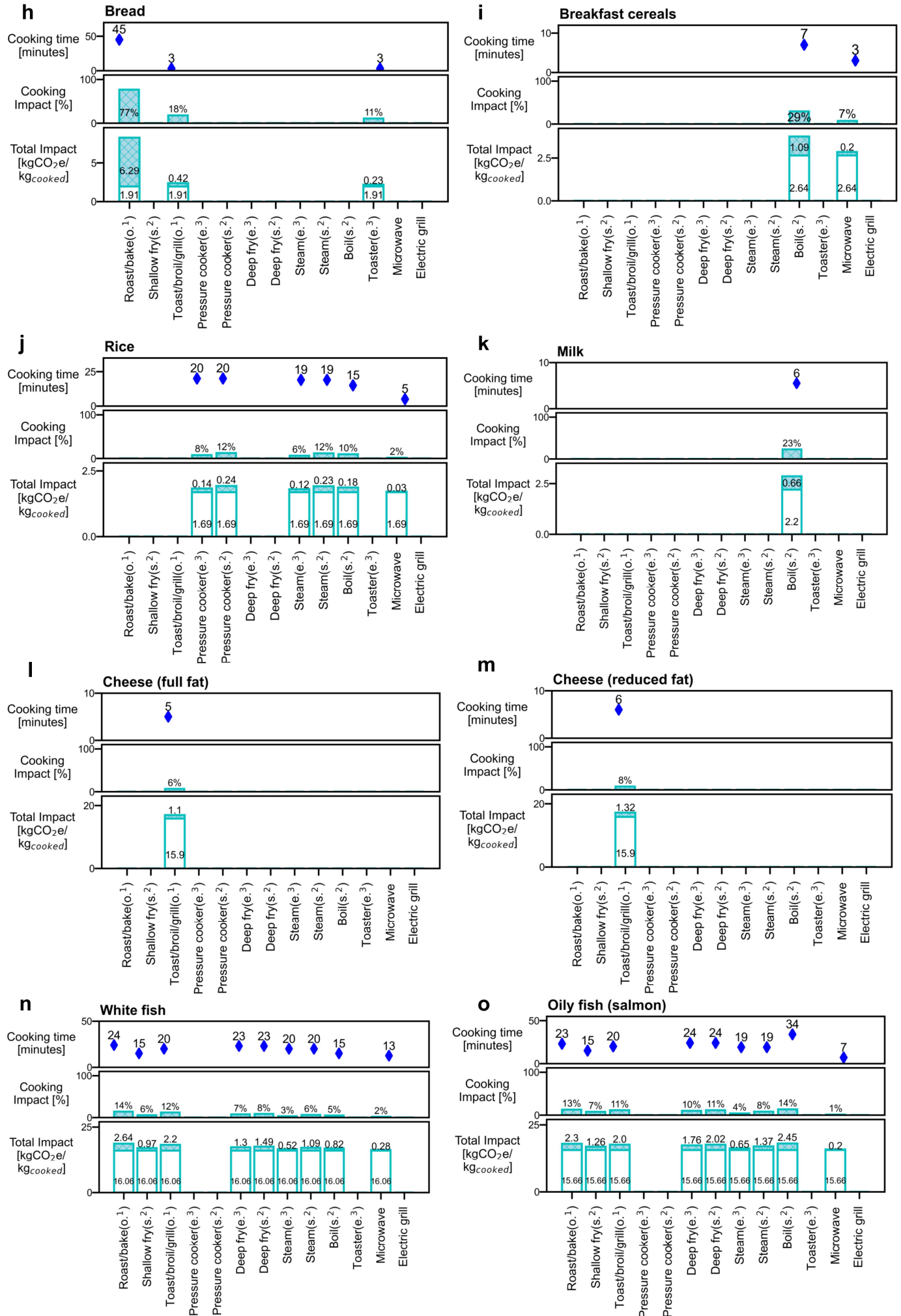

Supplementary figure 1: Greenhouse gas emissions of various cooking methods for different foods in relation to their cooking times by kg of cooked food? (continued)

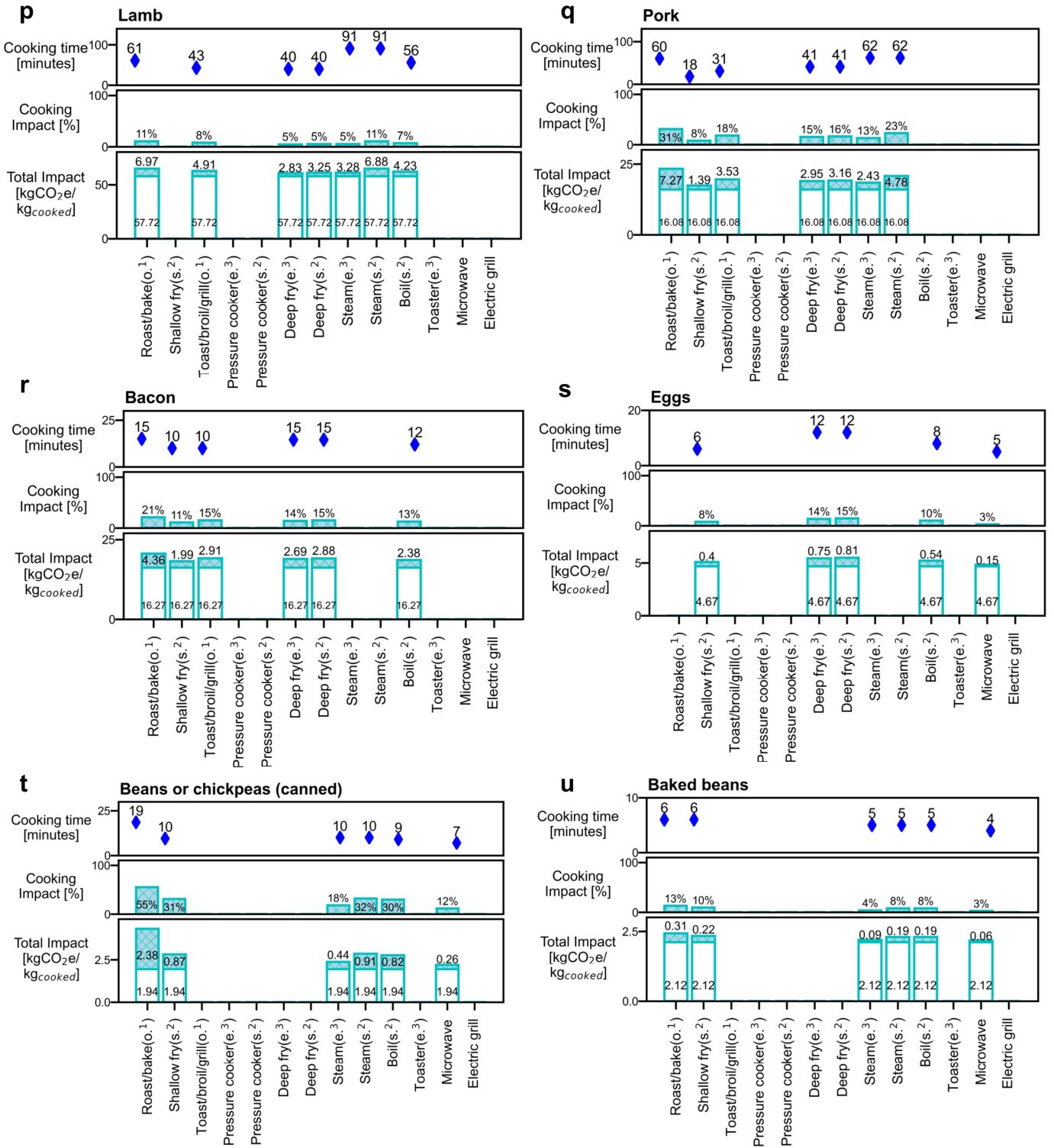

Supplementary figure 2a and b: Total greenhouse gas emissions of various food items including the share of cooking contribution to the total impact by protein (g) (Supplementary figure 2A)) and calorie (kcal) (Supplementary figure 2B)) content in cooked food.

Note: Conversion factors are applied to pasta (2.43), rice (2.63), potatoes, meats (0.62-0.79) and fish (0.77-1.19) to account for weight losses or gains of the raw products during cooking based on reference 13. For the remaining foods it is assumed that the conversion is negligible.

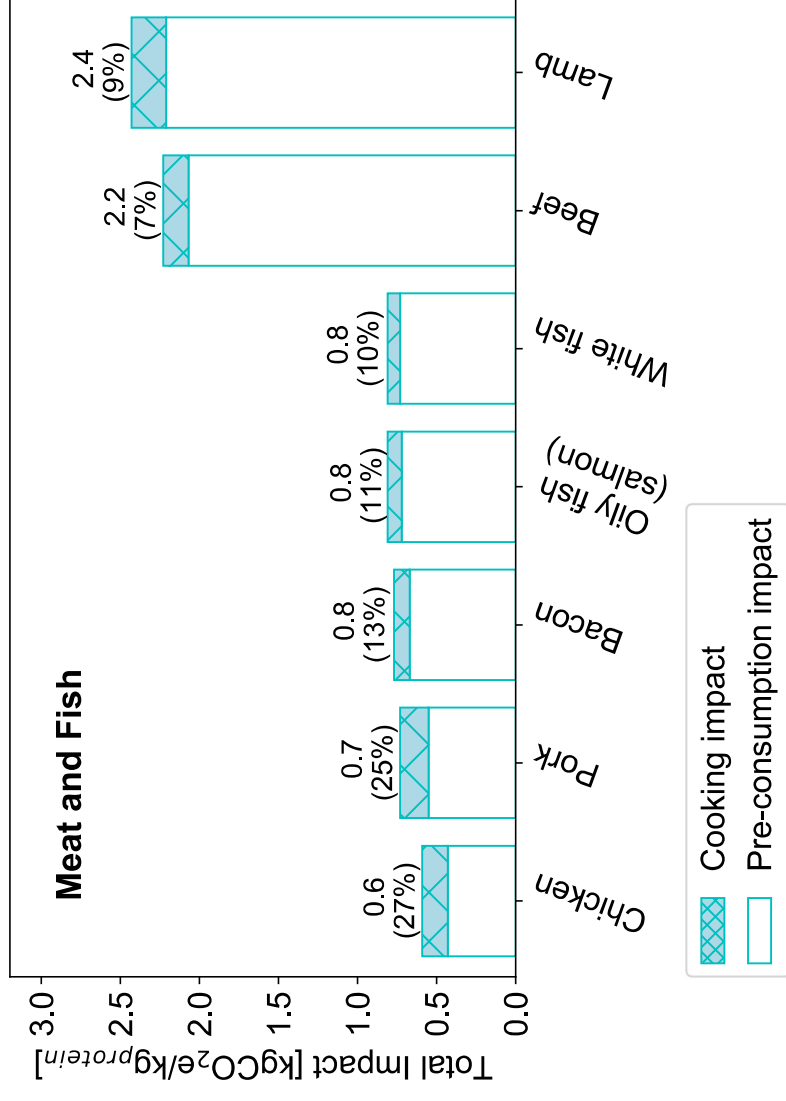
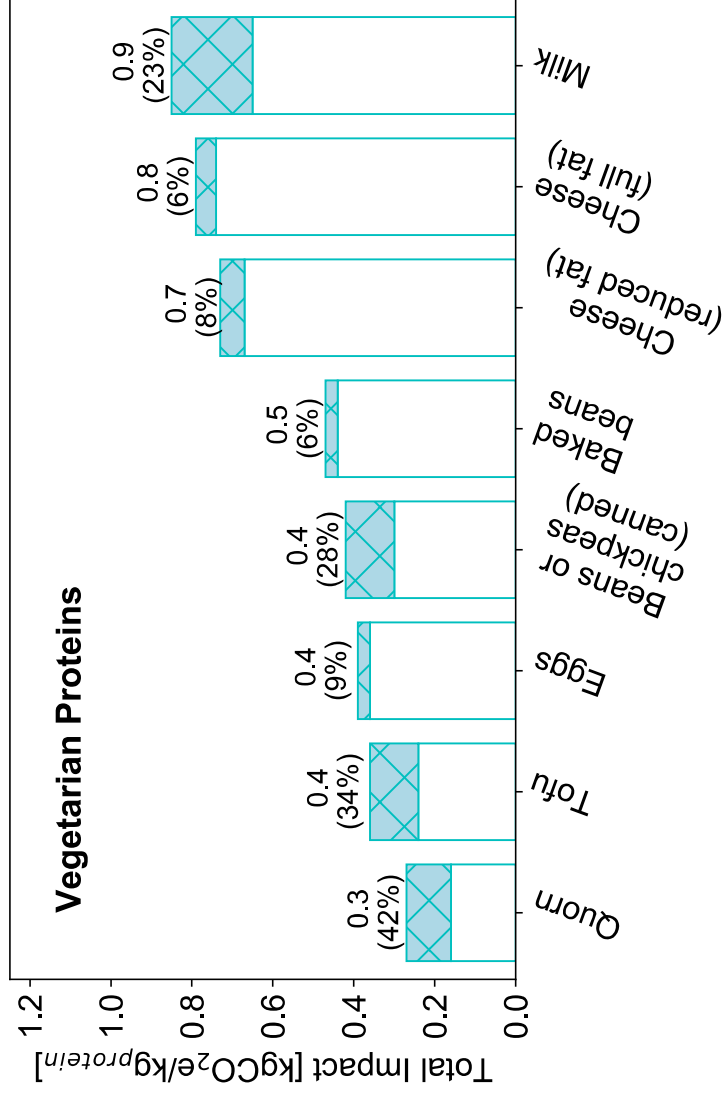
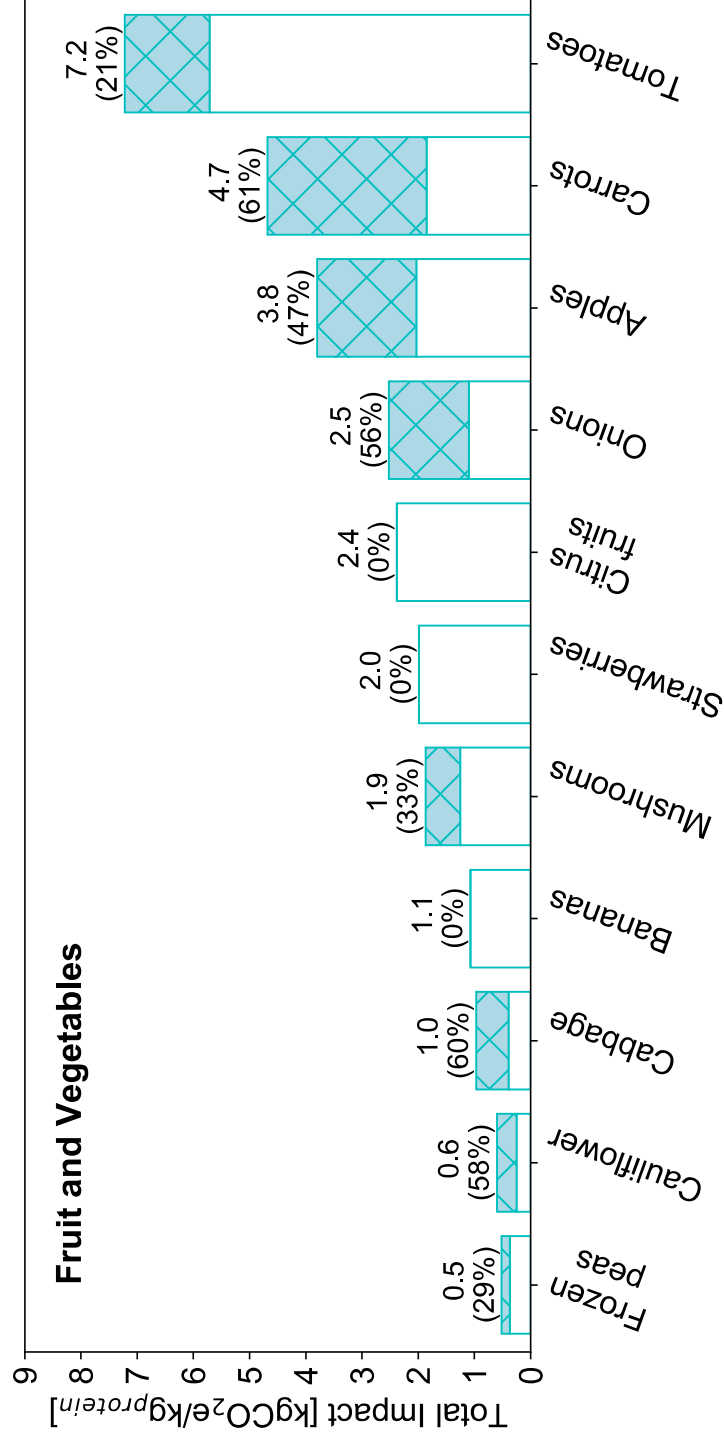
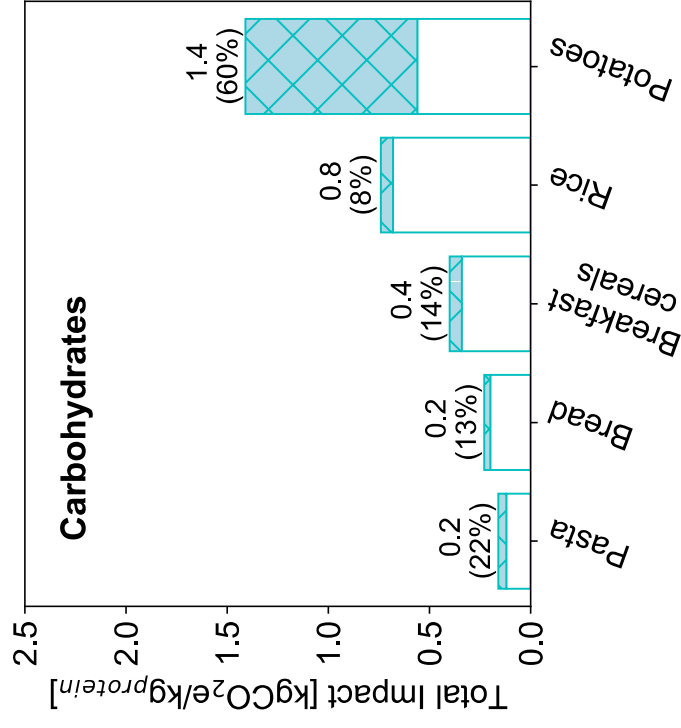

Supplementary figure 2B: Total greenhouse gas emissions of various food items including the share of cooking contribution to the total impact by protein (g) content in cooked food.

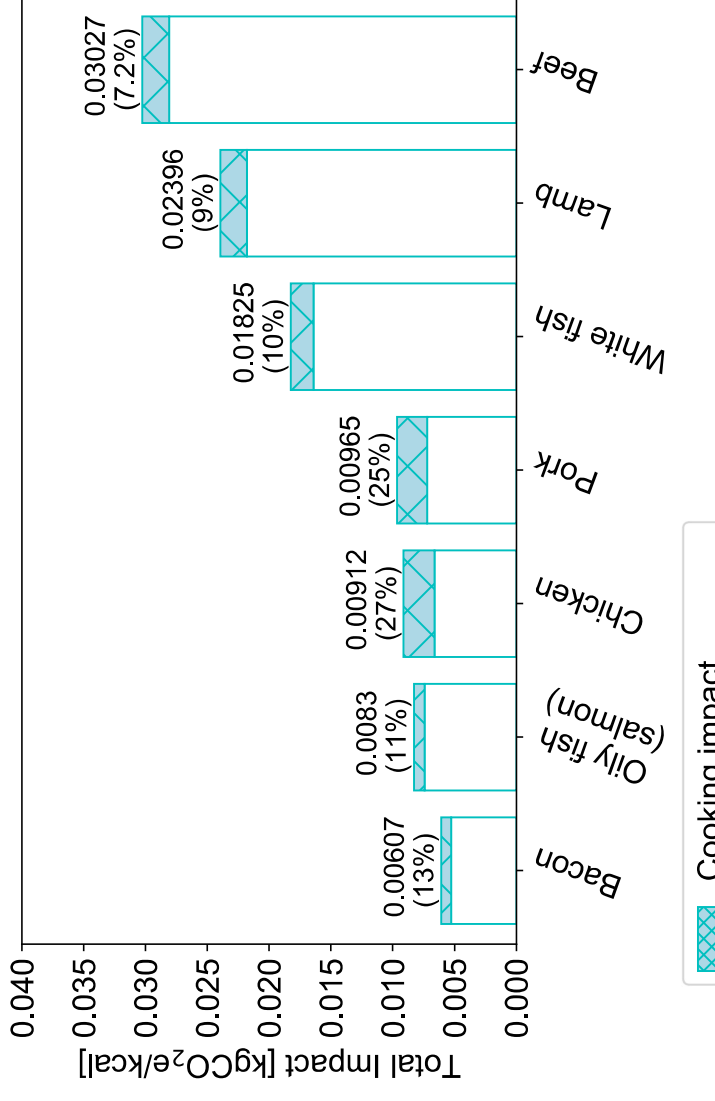
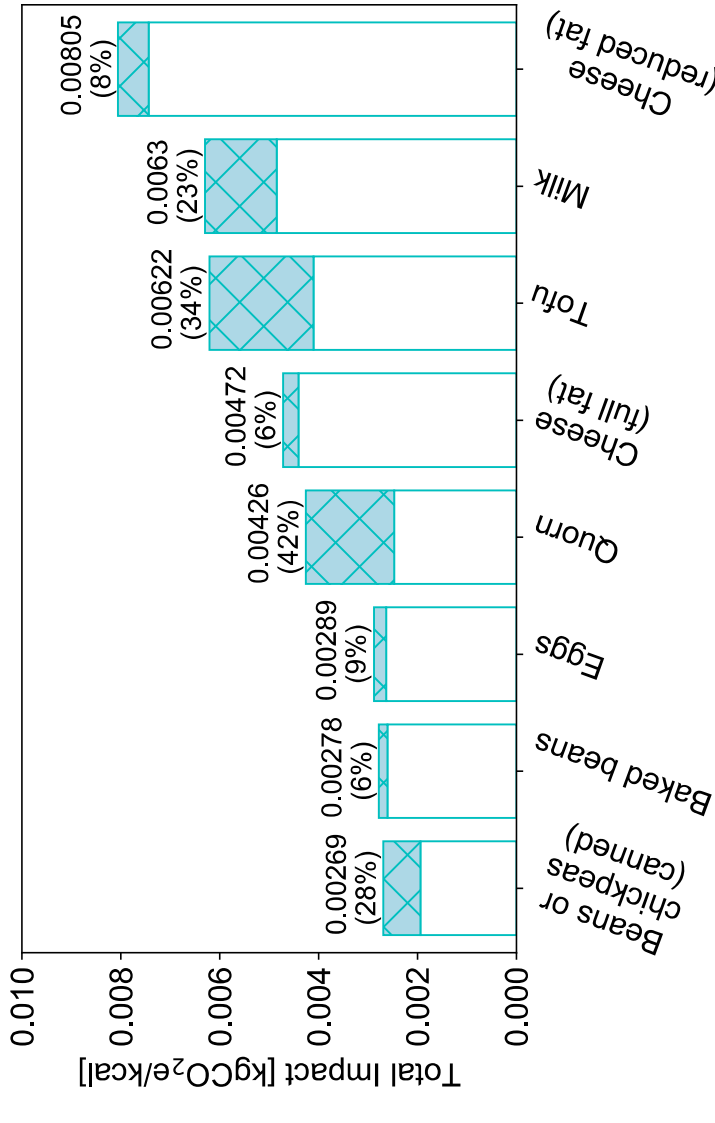
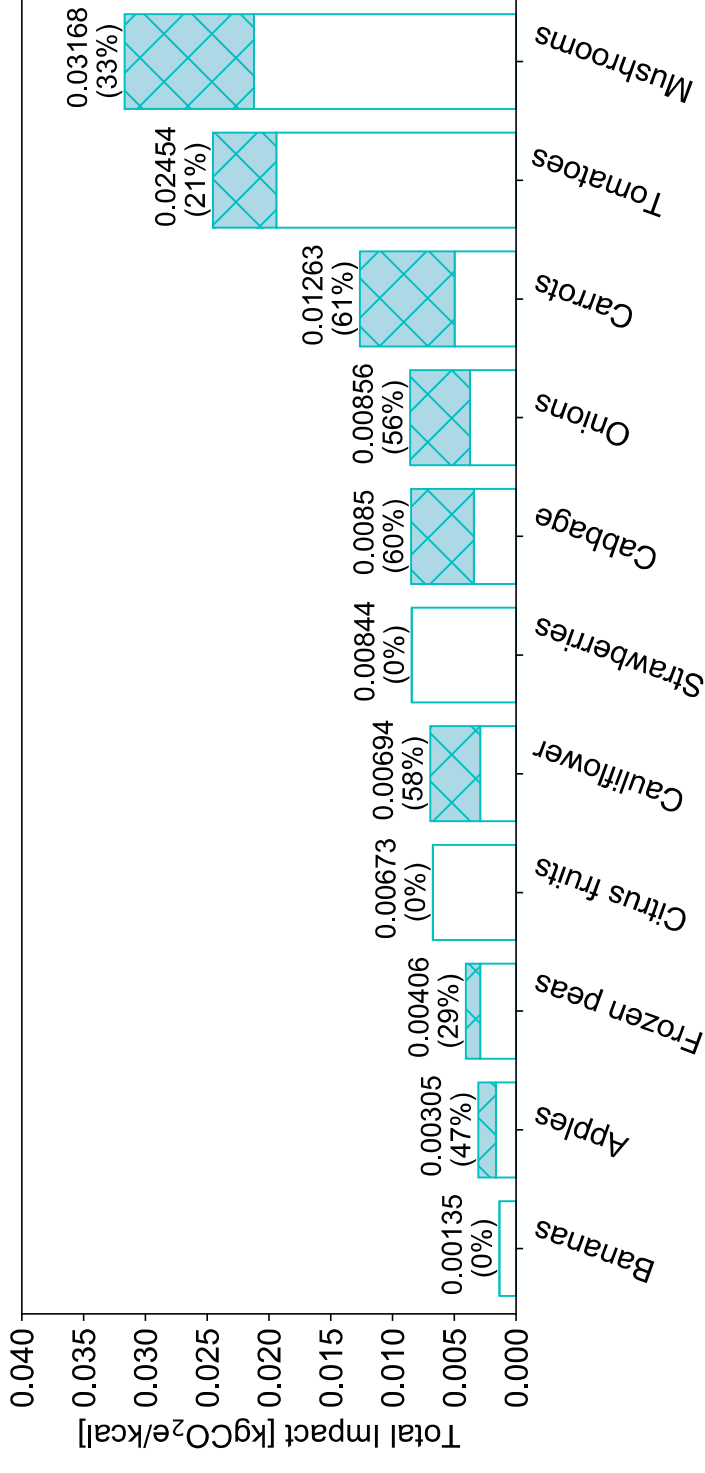
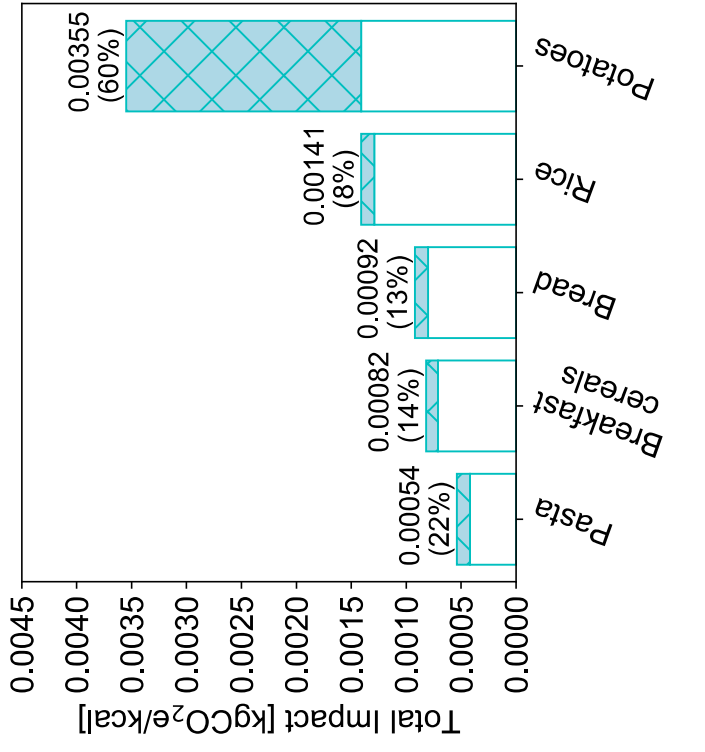

Supplementary figure 2B: Total greenhouse gas emissions of various food items including the share of cooking contribution to the total impact by calorie (kcal) content in cooked food.

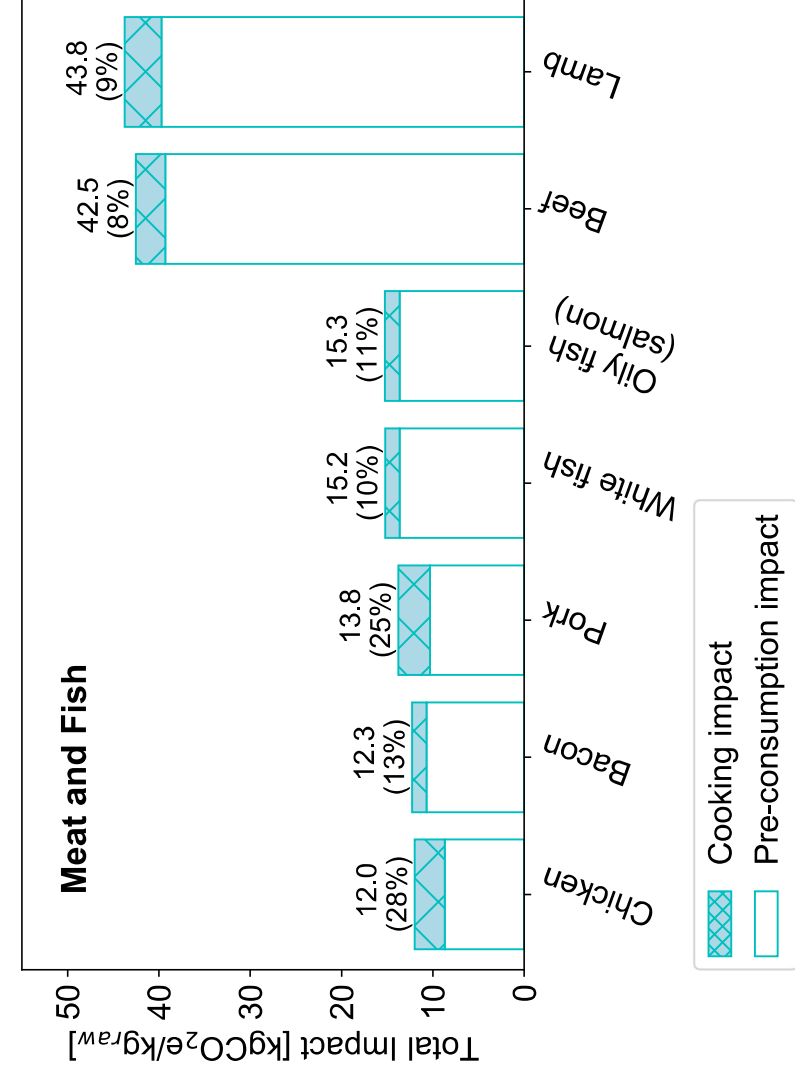
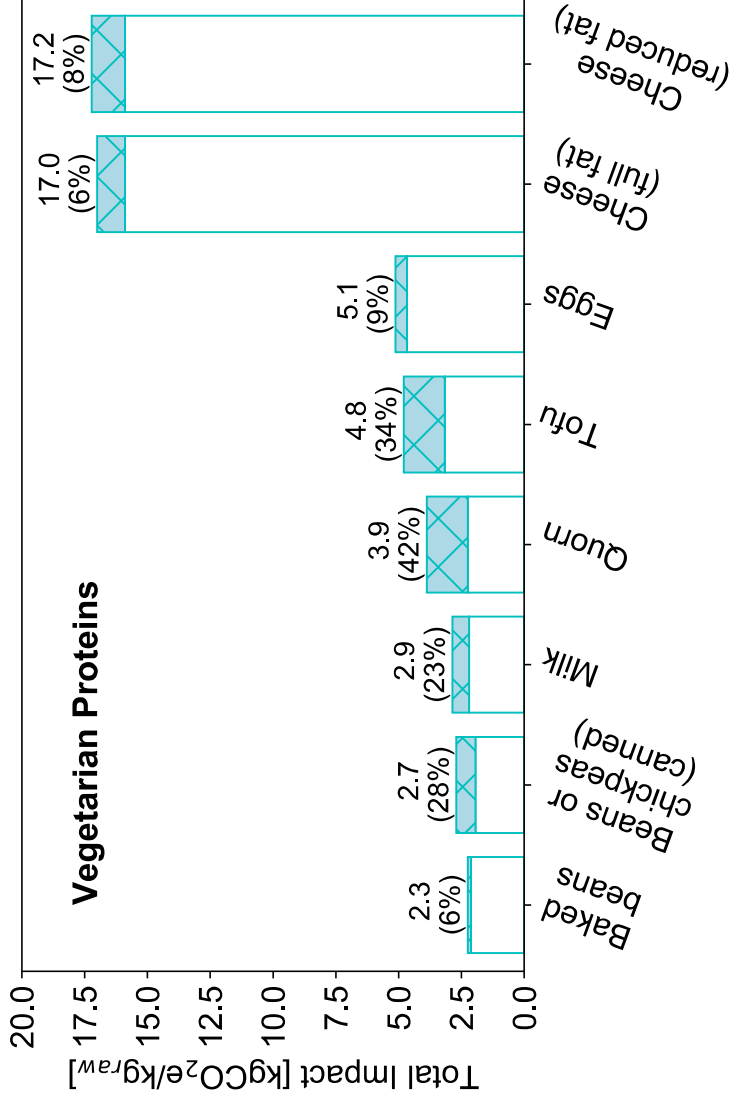
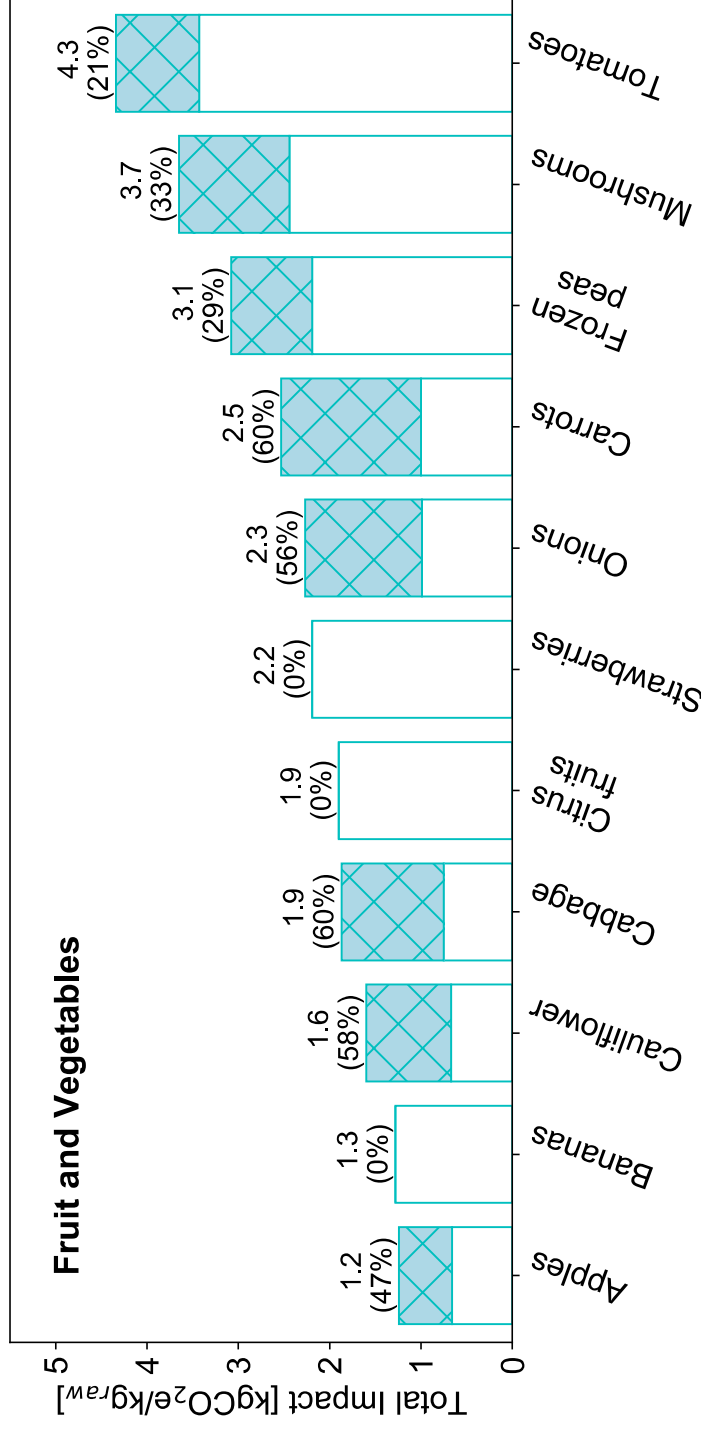
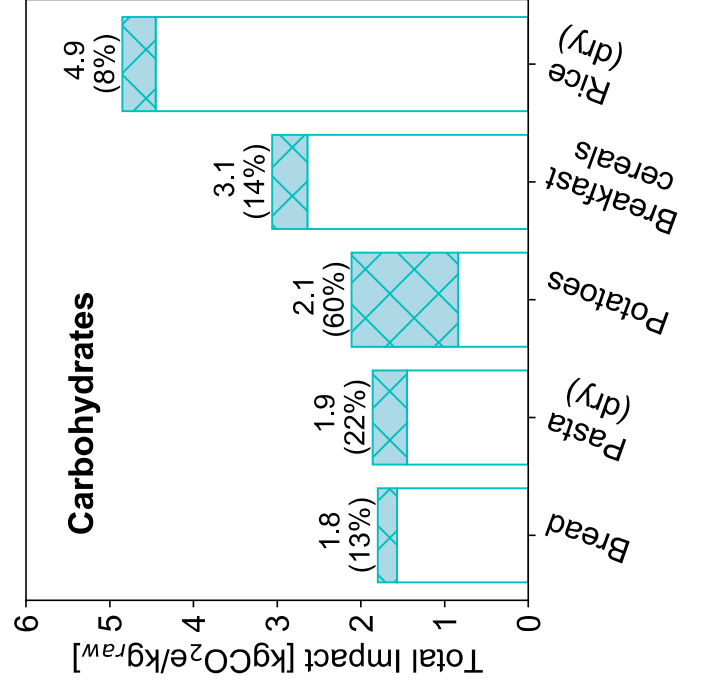

Supplementary figure 3: Results presented as "raw" (uncooked).

Supplementary figure 4: Percentage of respondents reporting typical cooking method

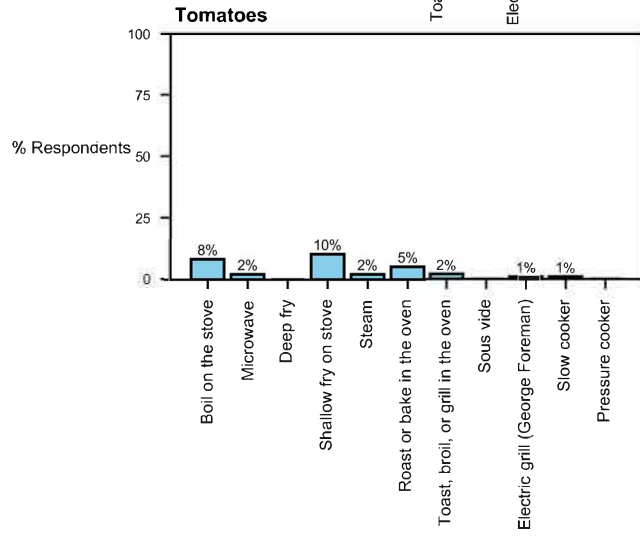
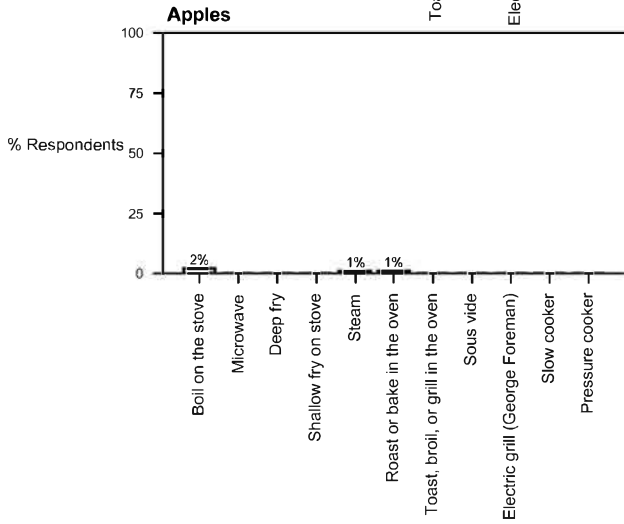
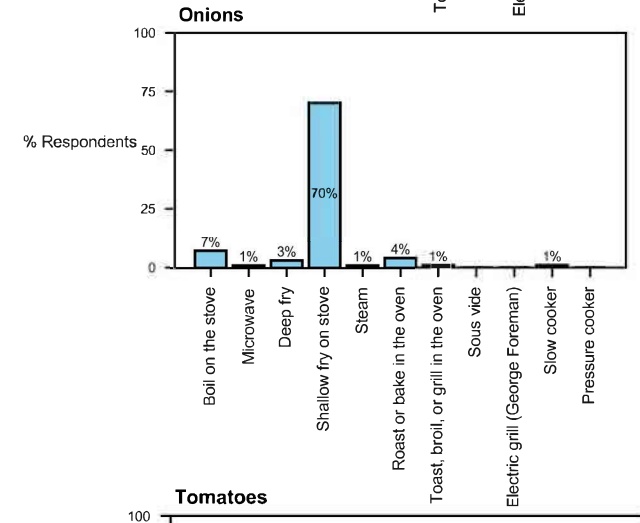
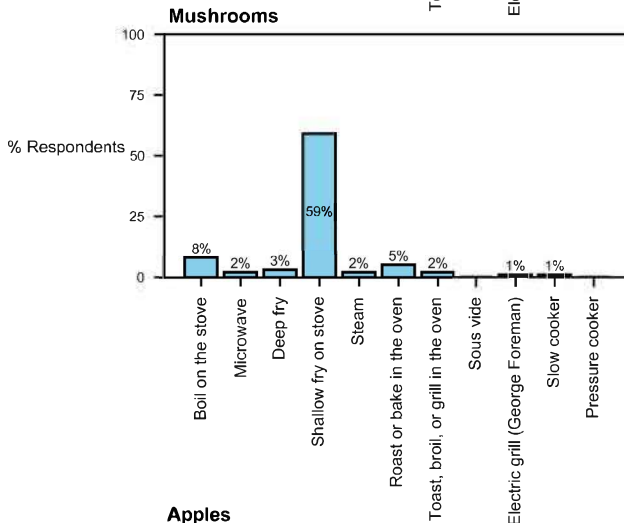
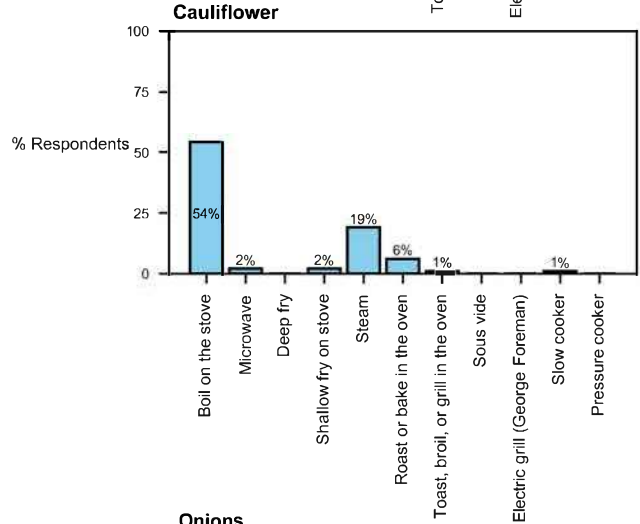
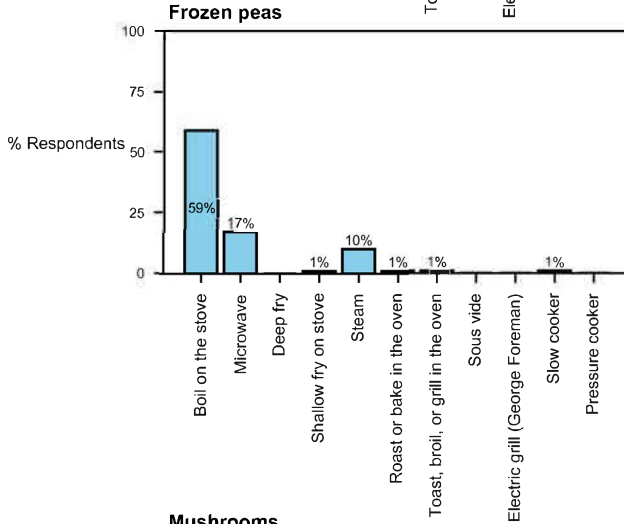
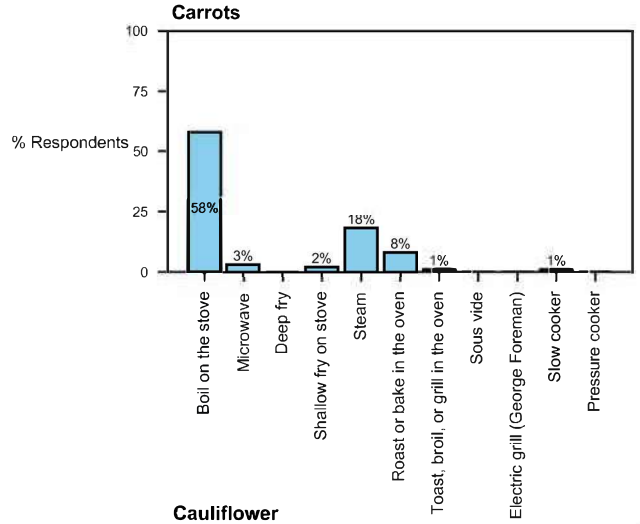
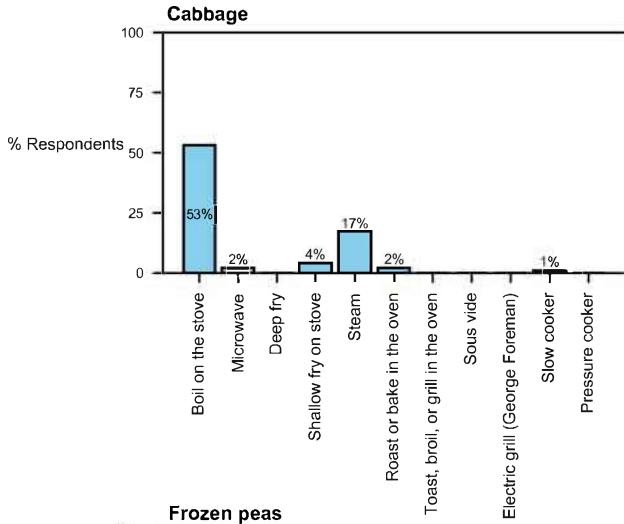

Supplementary figure 4: Percentage of respondents reporting typical cooking method (continued)

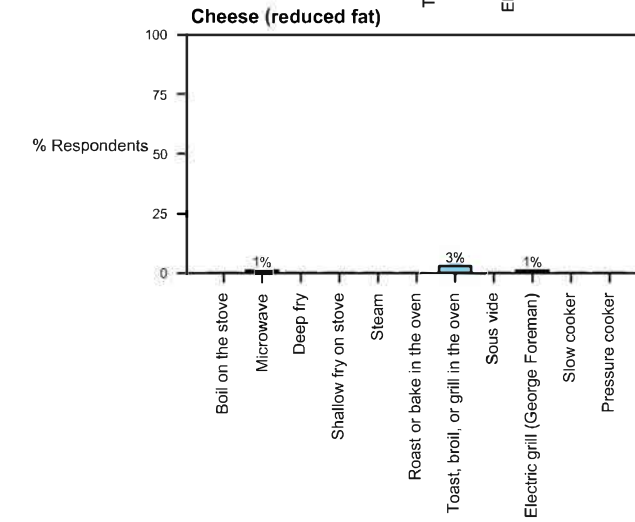
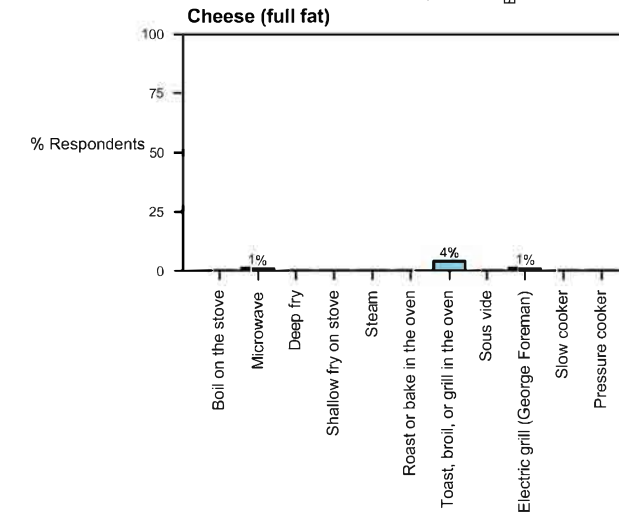
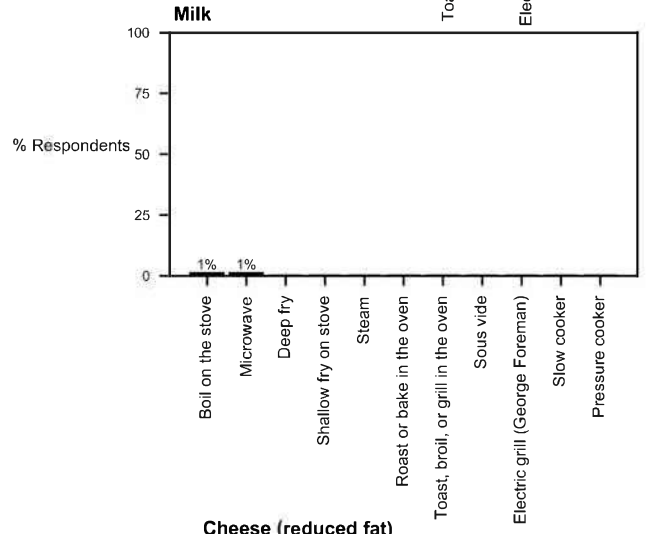
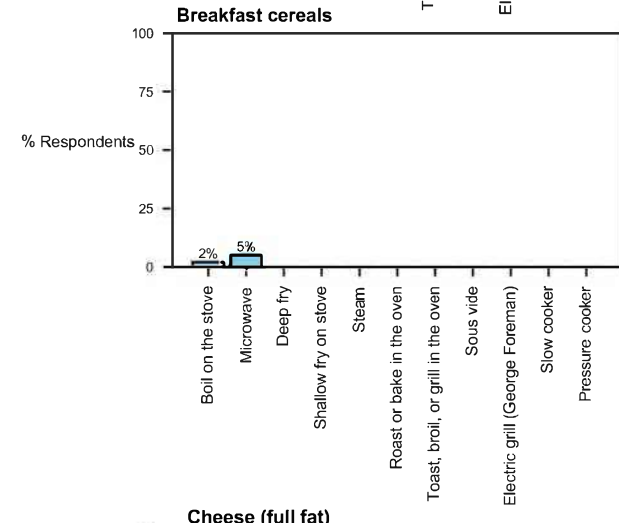
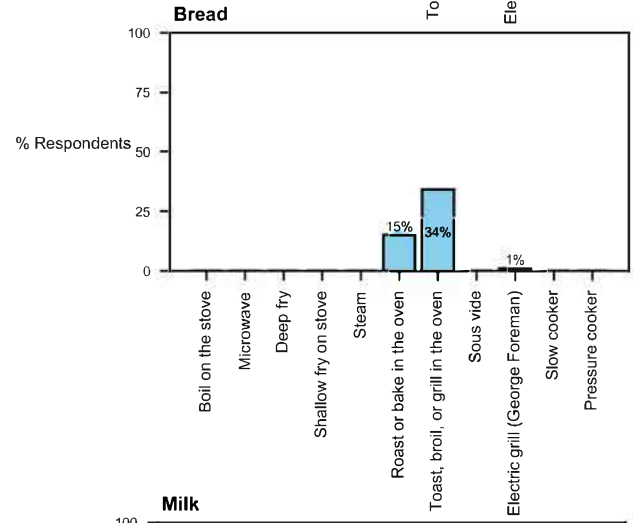
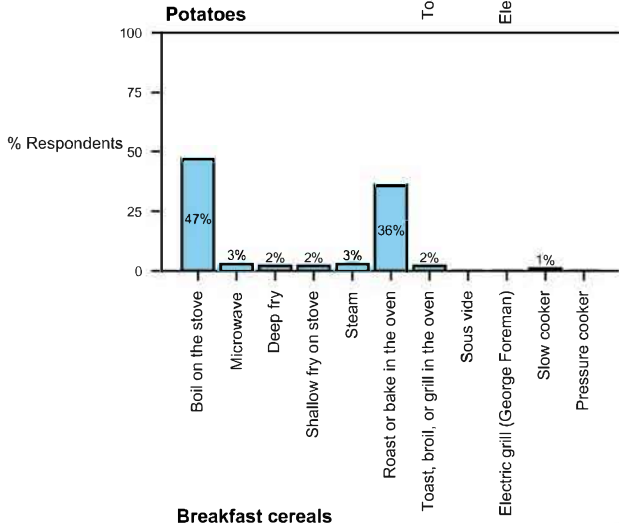
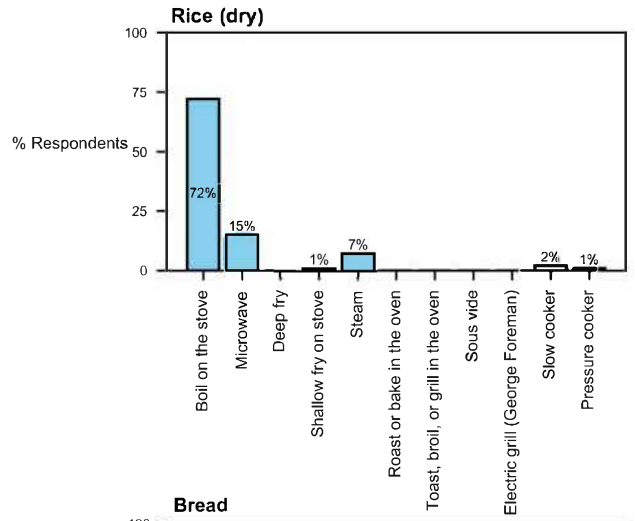
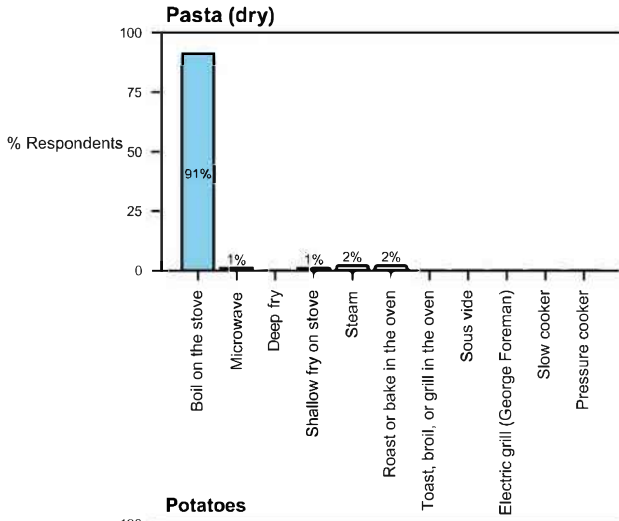

Supplementary figure 4: Percentage of respondents reporting typical cooking method (continued)

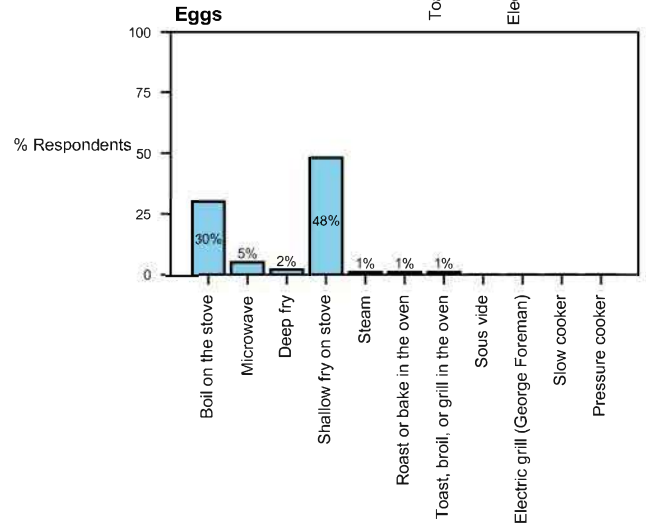
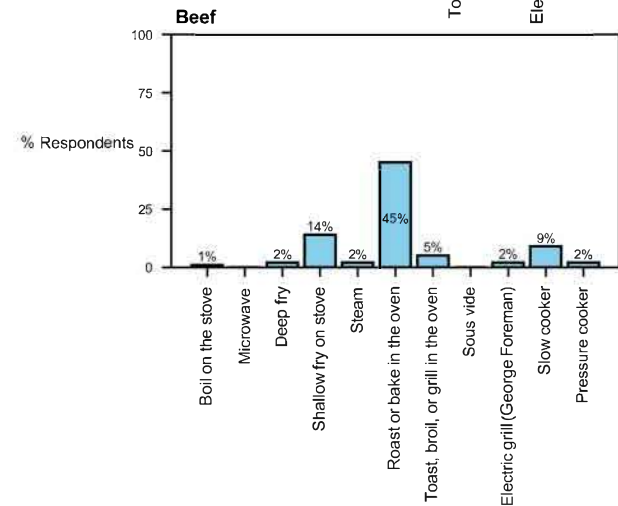
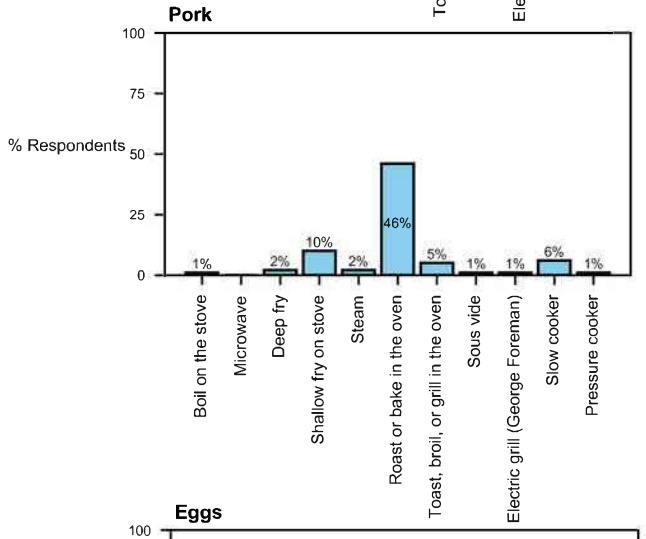
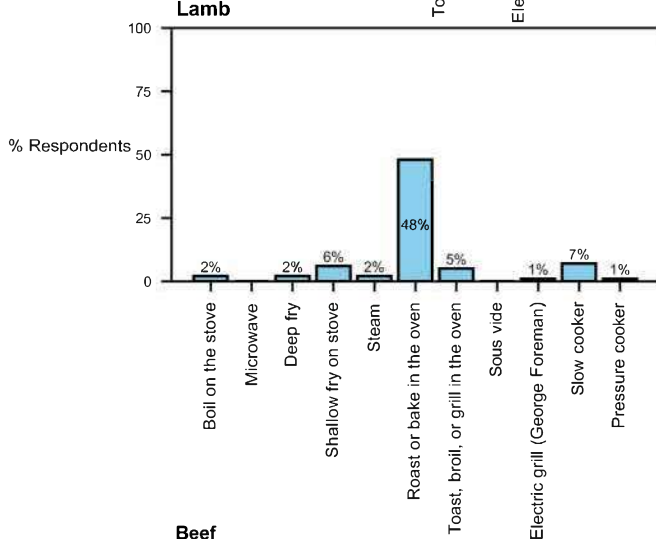
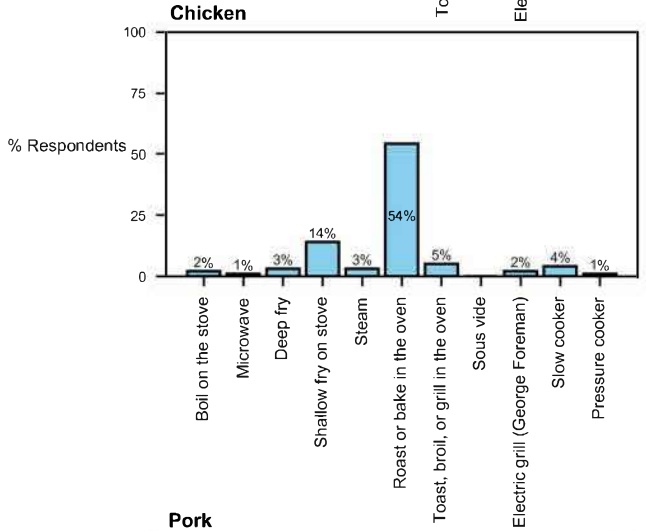
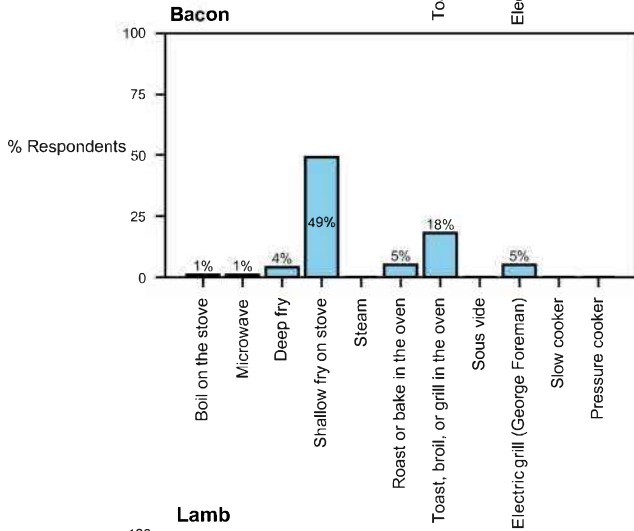
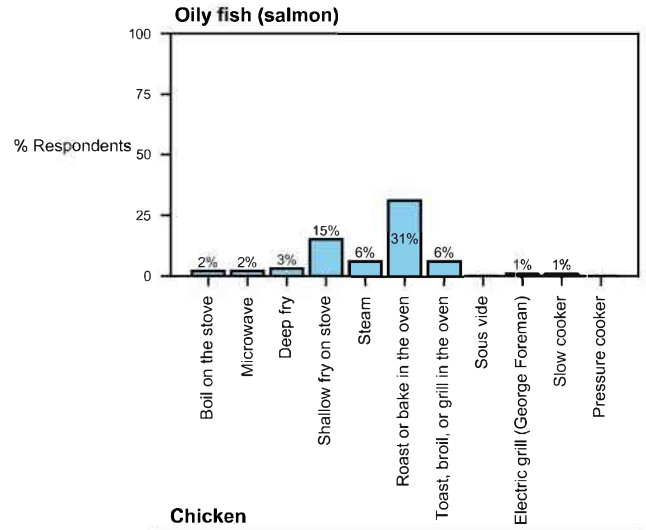
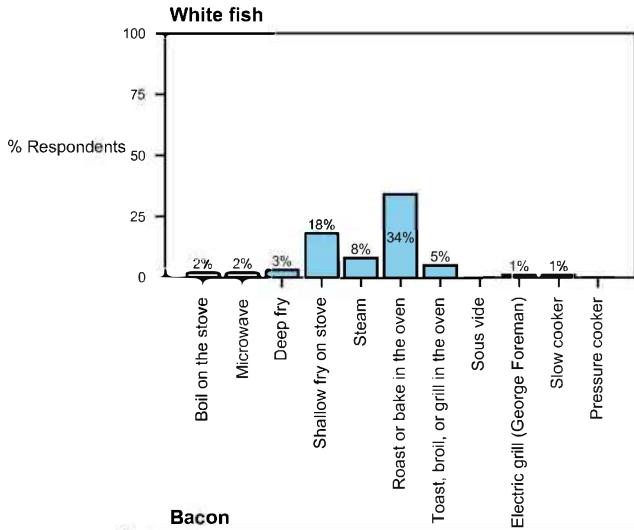

Supplementary figure 4: Percentage of respondents reporting typical cooking method (continued)

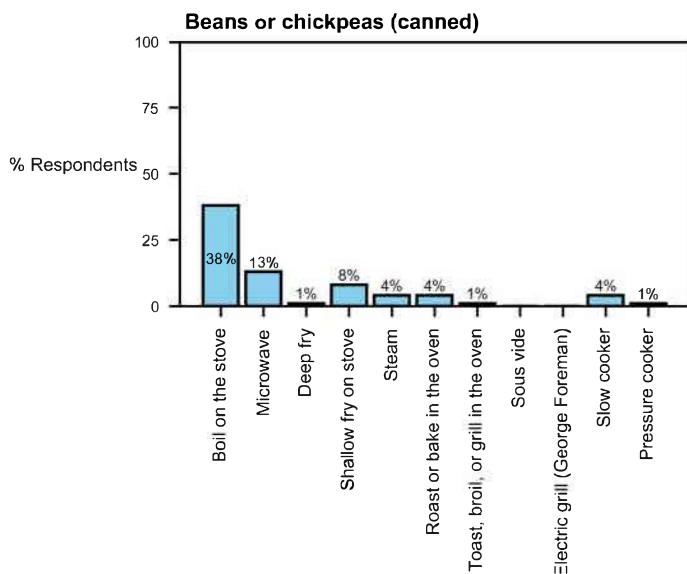
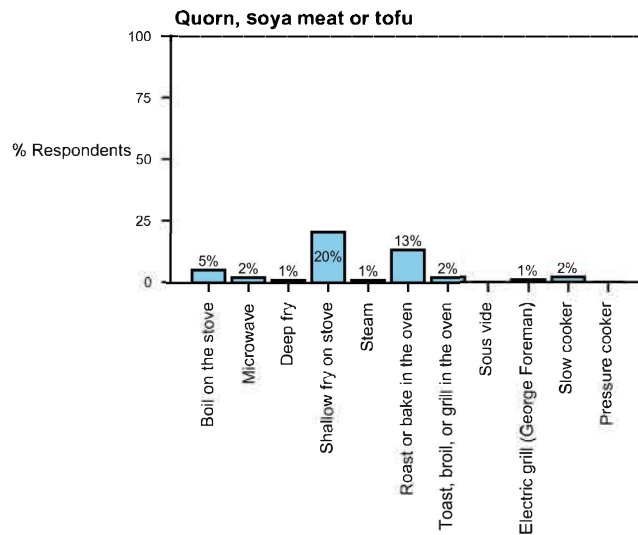
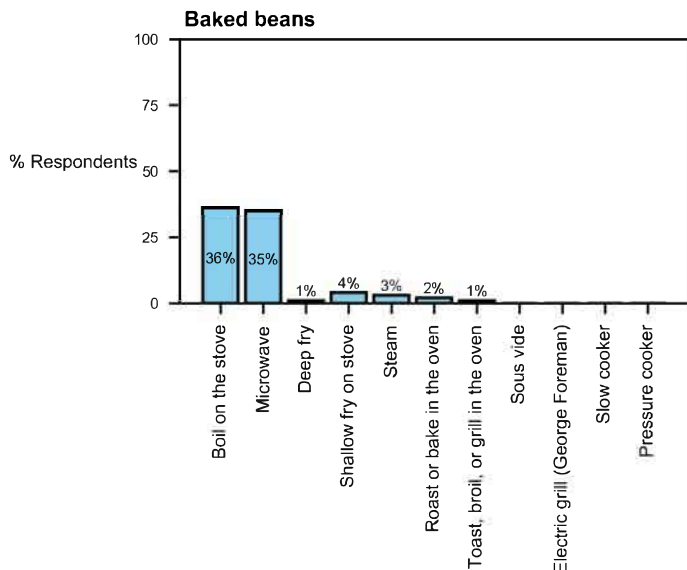

Supplementary table 1: Average energy consumption of cooking appliances based on manufacturer information

Table S1: Cooking appliances information based on manufacturer information

Energy consumption of cooking appliances ^a	Power ^b [W]				Sample size	GHG e ^c [kg CO ₂ e/kWh]
	Max	Min	Mean	SD		
Gas stove (boiling, steaming, shallow and deep frying)	5000	1000	2185	1186	108	0.446
Efficiency [%]	63%	54%	58%	2%	16.00	
Electric stove (boiling, steaming, shallow and deep frying)	7400	700	2162	949	122	0.553
Efficiency [kW/kg]	192	166	181	6	40	
Oven (roasting, baking, broiling, grilling, toasting)	3800	1200	3033	489	65	0.775
Microwave	1000	700	823	85	34	0.210
Electric grill	2400	760	1566	469	26	0.400
Toaster	2400	250	1470	507	124	0.376
Slow cooker (electric)	1200	110	231	188	55	0.059
Steam cooker (electric)	1900	400	970	443	21	0.248
Deep fryer (electric)	3000	900	1779	524	22	0.455
Pressure cooker (electric)	1460	900	1121	178	20	0.287
Sous vide (electric)	1500	750	1020	195	25	0.261

^a Appliances selection based on dedicated consumer facing websites such as Which? and best selling item lists from sellers like amazon

^b Information from appliances manuals and official manufacturer websites

^c Gas: 0.20428 kgCO₂e/kWh ; electricity: 0.2556 kg CO₂ e/kWh

Supplementary Table 3: Survey and literature data continued

Food item	Pre-consumption stage (CO2e/kg)	Reference	Portion size (g)	Conversion factor	Median cooking time (minutes)	I typically eat this food without cooking	I do not eat this food	Boil on the stove	Microwave	Deep fry	Shallow fry on stove	Steam	Roast or bake in the oven	Toast, broil, or grill in the oven	Electric grill F	Slow cooker	Pressure cooker
Strawberries	2.2	10 G	105.0	1	0	92%	7%	0%	0%	0%	0%	0%	0%	0%	0%	0%	0%
Milk	2.2	3 H	68.0	1	5.5	88%	9%	100%	0%	0%	0%	0%	0%	0%	0%	0%	0%
Cheese (full fat)	15.9	3 H	52.0	1	5.0	82%	11%	0%	0%	0%	0%	0%	0%	100%	0%	0%	0%
Cheese (reduced fat)	15.9	3 H	52.0	1	6.0	73%	21%	0%	0%	0%	0%	0%	0%	100%	0%	0%	0%
Eggs	4.7	3 A	121.0	1	6.8	4%	8%	36%	6%	3%	56%	0%	0%	0%	0%	0%	0%
Bacon	10.7	11	61.0	fried: 0.67; oven: 0.65	10.6	1%	15%	2%	0%	4%	59%	0%	6%	23%	5%	0%	0%
Beef	39.3	3 H	157.3	fried: 0.73; oven: 0.67	58.5	2%	17%	2%	0%	2%	16%	2%	57%	6%	2%	11%	2%
Lamb	39.7	3 A	157.3	0.7	63.0	2%	24%	2%	0%	3%	0%	3%	74%	7%	0%	11%	0%
Pork	10.3	3 H	157.3	fried: 0.67; oven: 0.654	53.1	1%	22%	0%	0%	3%	12%	2%	65%	8%	0%	9%	0%
Chicken	8.7	3 H	157.3	fried: 0.79; oven: 0.75	46.7	1%	11%	2%	0%	3%	15%	3%	64%	6%	2%	4%	0%
White fish	13.6	3	134.0	fried: 1; oven: 0.83	20.3	1%	24%	4%	3%	4%	25%	11%	47%	7%	0%	0%	0%
Oily fish (salmon)	13.6	3 A	134.0	fried: 0.77; oven: 0.91	20.4	5%	28%	3%	3%	5%	23%	8%	49%	9%	0%	0%	0%
Beans or chickpeas (canned)	1.9	5 C	95.0	1	10.0	8%	19%	53%	12%	0%	18%	5%	5%	0%	0%	6%	0%
Baked beans	2.1	5 C	233.0	1	4.6	8%	9%	45%	44%	0%	5%	3%	2%	0%	0%	0%	0%
Tofu	3.2	3 A	105.0	1	18.0	3%	48%	12%	6%	4%	47%	0%	30%	5%	0%	4%	0%
Quorn	2.3	12	105.0	1	18.0	3%	48%	12%	6%	4%	47%	0%	30%	5%	0%	4%	0%

A Global average; B Weighted average of UK production and imports of fresh produce (excl. household stage); C Weighted average of UK production and imports of fresh and processed produce; D excl. household; E Weighted average of UK production and imports of fresh and frozen produce; F European average; G George Foreman.

References

1. Recchia, L., Cappelli, A., Cini, E., Pegna, F. G. & Boncinelli, P. Environmental sustainability of pasta production chains: An integrated approach for comparing local and global chains. *Resources* **8**, (2019).
2. Cimini, A. & Moresi, M. Energy efficiency and carbon footprint of home pasta cooking appliances. *J. Food Eng.* **204**, 8–17 (2017).
3. Poore, J. & Nemecek, T. Reducing food's environmental impacts through producers and consumers. *Science (80-.)*. **360**, 987–992 (2018).
4. Jeswani, H., Burkinshaw, R. & Azapagic, A. Environmental sustainability issues in the food-energy-water nexus: Breakfast cereals and snacks. *Sustain. Prod. Consum.* 1–12 (2015). doi:10.1016/j.spc.2015.08.001
5. Frankowska, A., Jeswani, H. K. & Azapagic, A. Environmental impacts of vegetables consumption in the UK. *Sci. Total Environ.* **682**, 80–105 (2019).
6. Robinson, B., Winans, K., Kendall, A., Dlott, J. & Dlott, F. A life cycle assessment of *Agaricus bisporus* mushroom production in the USA. *Int. J. Life Cycle Assess.* **24**, 456–467 (2019).
7. Usubharatana, P. & Phungrassami, H. Life cycle assessment of the straw mushroom production. *Appl. Ecol. Environ. Res.* **14**, 367–382 (2016).
8. Gunady, M. G. A., Biswas, W., Solah, V. A. & James, A. P. Evaluating the global warming potential of the fresh produce supply chain for strawberries, romaine/cos lettuces (*Lactuca sativa*), and button mushrooms (*Agaricus bisporus*) in Western Australia using life cycle assessment (LCA). *J. Clean. Prod.* **28**, 81–87 (2012).
9. Blonk, H., Kool, A., Luske, B., Ponsioen, T. & Scholten, J. Methodology for assessing carbon footprints of horticultural products horticultural products. (2010).
10. Frankowska, A., Jeswani, H. K. & Azapagic, A. Life cycle environmental impacts of fruits consumption in the UK. *J. Environ. Manage.* **248**, 109111 (2019).
11. Noya, I. *et al.* Carbon and water footprint of pork supply chain in Catalonia: From feed to final products. *J. Environ. Manage.* **171**, 133–143 (2016).
12. Quorn. Carbon footprinting emissions report. (2019)
13. Finglas, P. M. *et al.* *McCance and Widdowson's The Composition of Foods*. (2015).

Supplementary text 2: Questionnaire from Survey

Ethics

There is detailed information about foods available to the nutritionists, however, we do not know, (and cannot measure easily) what normal people understand or perceive to know about food. This survey measured what people know about 30 common food items.

Please take time to read the following information carefully before you decide whether or not you wish to take part.

What is the study about?

This pilot will use the Qualtrics platform to ask citizens to provide their perceptions about images of specific food serving sizes. For each image, one of a range of questions will be asked including perceptions of greenhouse gas emissions and energy (calorie content), cooking and preparation time, food safety and animal welfare.

Why have I been invited?

You have been selected via a panel provider as you fit within the selection criteria.

What will I be asked to do if I take part?

If you decided to take part, this would involve your participation in a survey.

What are the possible benefits from taking part?

There are no direct benefit to you, however, you have our thanks for taking part in the survey.

Do I have to take part?

No. It's completely up to you to decide whether or not you take part. Your participation is voluntary.

What if I change my mind?

All data will be anonymised and coded. If you change your mind, you are free to withdraw at any time during your participation in this study. If you want to withdraw, please let the researchers know, and we will extract any data you contributed to the study and destroy them. However, it is difficult and often impossible to take out data from one specific participant when this has already been anonymised or pooled together with other people data. Therefore, you can only withdraw up to 6 weeks after taking part in the stu

What are the possible disadvantages and risks of taking part?

It is unlikely that there will be any major disadvantages to taking part. Taking part will mean investing up to 20 minutes for a survey.

Will my data be identifiable?

Only the researchers conducting this study will have access to the ideas and information you share you share with us. We are not collecting any personal identifiable information other than your age, weight, height and postcode.

How will we use the information you have shared with us and what will happen to the results of the research study?

We will use the information you have shared with me only in the following ways: We will use it for research purposes only. This will include academic and professional articles, policy

and best practice guidelines. We may also present the results of my study at academic and practitioner conferences.

How my data will be stored

Your data will be stored in encrypted files (that is no-one other than me, the researcher will be able to access them) and on password-protected computers. We will store hard copies of any data securely in locked cabinets in my office. We will keep data that can identify you separately from non-personal information (e.g. your views on a specific food). In accordance with University guidelines, we will keep the data securely for a minimum of ten years. We will keep data that can identify you separately from non-personal information (e.g. your views on a specific topic).

Who has reviewed the project?

The University of Sheffield Research Ethics Committee (Reference Number#019076)

What if I have a question or concern?

If you have any queries or if you are unhappy with anything that happens concerning your participation in the study, please contact Lead Researcher for the University of Sheffield: Christian Reynolds (c.reynolds@sheffield.ac.uk)

If you are happy with this information please give your consent to participate on the next page.

By clicking the 'Next' (arrow button) below I consent to the following

I confirm that I have read and understand the information sheet for the above study. I have had the opportunity to consider the information, ask questions and have had these answered satisfactorily.

I understand that my participation is voluntary and that I am free to withdraw at any time during my participation in this study and within 6 weeks after I took part in the study, without giving any reason. If I withdraw within 6 weeks of taking part in the study my data will be removed.

I understand that any information given by me may be used in future reports, academic articles, publications or presentations by the researcher/s, but my personal information will not be included and I will not be identifiable.

I understand that my name/my organisation's name will not appear in any reports, articles or presentation without my consent.

I understand that data will be kept according to University guidelines for a minimum of 10 years after the end of the study.

I agree to take part in the above study.

Country

In which country do you currently reside?

Demographics

Please enter your age (in years).

	0	10	20	30	40	50	60	70	80	90	100	
Age (years)												<input type="text"/>

Please select your preferred system of measuring your height and weight

- Metric system (CM, Kg)
- Imperial system (Inches, Pounds)

Please enter your height (in cm), and weight (in kg)

	0	20	40	60	80	100	120	140	160	180	200	
Height (cm)												<input type="text"/>
Weight (kg)												<input type="text"/>

Please enter your height (in inches), and weight (in pounds)

	0	30	60	90	120	150	180	210	240	270	300	
Height (Inches)												<input type="text"/>
Weight (pounds)												<input type="text"/>

What is your gender?

- Male
- Female
- Other
- Prefer not say

Please enter your Postcode.

How would you describe your diet

- Omnivore, I am not very interested in even trying vegetarian food except occasionally
- Omnivore, I am happy to try some vegetarian dishes as well
- Omnivore, I also often eat vegetarian dishes or have vegetarian dishes as well
- Pescetarian, I eat fish, dairy and eggs in addition to products derived from plants
- Ovo-lacto vegetarian, I eat dairy and eggs in addition to products derived from plants
- Lacto-vegetarian, I eat dairy in addition to products derived from plants
- Vegan, I only eat products derived from pla
- Other dietary requirements or choices

Do you limit your meat intake for any of the following reasons? (you may select more than one response)

- I do not limit my intake
- I limit my meat intake due to environmental concerns
- I limit due to Animal Welfare concerns
- I limit my meat intake because I do not enjoy the taste
- I limit my meat intake due to concerns for my health
- I limit my meat intake because it is expensive
- Other (please describe)

What is the size of your household?

- One person household
- More than one person in household

What is the size of your household?

	0	1	2	3	4	5	6	7	8	9	10	
Number of adults aged 16 and over in household												<input type="text"/>
Number of Children aged between 18 months to 16 years old												<input type="text"/>
Number of Children aged between 0 and 18 months												<input type="text"/>

How is food usually prepared in your household?

- From scratch
 With the use of semi-finished products
 With the use of processed foods

How often do you cook or prepare food for others?

- Every day or nearly every day
 Several times a week
 Once or twice a week
 Less frequently

How often do you cook or prepare food for yourself?

- Every day or nearly every day
 Several times a week
 Once or twice a week
 Less frequently

Please indicate which of these equipment you have in your kitchen

- a refrigerator
 a freezer (excluding freezer compartment at top of fridge)
 a microwave oven

- electric hob (ring)
- a gas hob (ring)
- an electric grill (such as George Foreman)
- an oven
- a kettle
- a sous vide machine
- a toaster
- a slow cooker
- a pressure cooker
- a food processor
- None of these

On average, how often do you eat in fast-food or takeaway restaurants

- Rarely Or Never
- Several Times Per Month
- Several Times Per Week
- Once a Day or Most Days
- Most meals

Preparation

According to your best guess, please estimate how long (in minutes) it takes you to actively prepare the foods listed below for you to eat (i.e. chop, washing, mixing, weighing) .

Note: Preparation time does not include cooking time.

If the food takes longer than 60 minutes (1 hour) of active preparation, please select "60". If the food is eaten with no preparation please select "0".

We will ask many people the same question about these foods , so don't worry if you aren't absolutely sure. Just give us your best guess.

		Minutes of preparation							
		0	10	20	30	40	50	60	
	Pasta								<input type="text"/>
	Rice								<input type="text"/>
	Bread								<input type="text"/>
	Breakfast cereal								<input type="text"/>

Minutes of preparation

	0	10	20	30	40	50	60	
Potatoes								<input type="text"/>
Carrots								<input type="text"/>
Tomatoes								<input type="text"/>
Frozen Peas								<input type="text"/>
Cabbages								<input type="text"/>
Cauliflowers								<input type="text"/>
Mushrooms								<input type="text"/>
Onions								<input type="text"/>
Apples								<input type="text"/>
Citrus fruit								<input type="text"/>
Bananas								<input type="text"/>
Strawberries								<input type="text"/>
Milk								<input type="text"/>
Cheese (full fat)								<input type="text"/>
Cheese (reduced fat)								<input type="text"/>
Eggs								<input type="text"/>
Bacon								<input type="text"/>
Beef								<input type="text"/>
Lamb								<input type="text"/>

Minutes of preparation

	0	10	20	30	40	50	60	
Pork								<input type="text"/>
Chicken								<input type="text"/>
White fish								<input type="text"/>
Oily fish (Salmon)								<input type="text"/>
Beans eg kidney beans or chickpeas (canned)								<input type="text"/>
Baked beans								<input type="text"/>
Soya meat or Quorn								<input type="text"/>

Cooking

According to your best guess, please provide the typical method you used to cook the foods listed below when you eat them.

	Shallow fry on stove	Deep fry	Roast or bake in the oven	Steam	Boil on the stove	Microwave	Toa broil, or grill in the oven	Sous vide	In a slow cooker	In a pressure cooker	Use an electric grill (such as George Foreman)	I typically eat this food as purchased without further cooking	I do not eat this food
Pasta	<input type="radio"/>	<input type="radio"/>	<input type="radio"/>	<input type="radio"/>	<input type="radio"/>	<input type="radio"/>	<input type="radio"/>	<input type="radio"/>	<input type="radio"/>	<input type="radio"/>	<input type="radio"/>	<input type="radio"/>	<input type="radio"/>
Rice	<input type="radio"/>	<input type="radio"/>	<input type="radio"/>	<input type="radio"/>	<input type="radio"/>	<input type="radio"/>	<input type="radio"/>	<input type="radio"/>	<input type="radio"/>	<input type="radio"/>	<input type="radio"/>	<input type="radio"/>	<input type="radio"/>
Bre	<input type="radio"/>	<input type="radio"/>	<input type="radio"/>	<input type="radio"/>	<input type="radio"/>	<input type="radio"/>	<input type="radio"/>	<input type="radio"/>	<input type="radio"/>	<input type="radio"/>	<input type="radio"/>	<input type="radio"/>	<input type="radio"/>
Breakfast cereal	<input type="radio"/>	<input type="radio"/>	<input type="radio"/>	<input type="radio"/>	<input type="radio"/>	<input type="radio"/>	<input type="radio"/>	<input type="radio"/>	<input type="radio"/>	<input type="radio"/>	<input type="radio"/>	<input type="radio"/>	<input type="radio"/>
Potatoes	<input type="radio"/>	<input type="radio"/>	<input type="radio"/>	<input type="radio"/>	<input type="radio"/>	<input type="radio"/>	<input type="radio"/>	<input type="radio"/>	<input type="radio"/>	<input type="radio"/>	<input type="radio"/>	<input type="radio"/>	<input type="radio"/>
Carrots	<input type="radio"/>	<input type="radio"/>	<input type="radio"/>	<input type="radio"/>	<input type="radio"/>	<input type="radio"/>	<input type="radio"/>	<input type="radio"/>	<input type="radio"/>	<input type="radio"/>	<input type="radio"/>	<input type="radio"/>	<input type="radio"/>
Tomatoes	<input type="radio"/>	<input type="radio"/>	<input type="radio"/>	<input type="radio"/>	<input type="radio"/>	<input type="radio"/>	<input type="radio"/>	<input type="radio"/>	<input type="radio"/>	<input type="radio"/>	<input type="radio"/>	<input type="radio"/>	<input type="radio"/>
Frozen Peas	<input type="radio"/>	<input type="radio"/>	<input type="radio"/>	<input type="radio"/>	<input type="radio"/>	<input type="radio"/>	<input type="radio"/>	<input type="radio"/>	<input type="radio"/>	<input type="radio"/>	<input type="radio"/>	<input type="radio"/>	<input type="radio"/>
Cabbages	<input type="radio"/>	<input type="radio"/>	<input type="radio"/>	<input type="radio"/>	<input type="radio"/>	<input type="radio"/>	<input type="radio"/>	<input type="radio"/>	<input type="radio"/>	<input type="radio"/>	<input type="radio"/>	<input type="radio"/>	<input type="radio"/>
Cauliflowers	<input type="radio"/>	<input type="radio"/>	<input type="radio"/>	<input type="radio"/>	<input type="radio"/>	<input type="radio"/>	<input type="radio"/>	<input type="radio"/>	<input type="radio"/>	<input type="radio"/>	<input type="radio"/>	<input type="radio"/>	<input type="radio"/>
Mushrooms	<input type="radio"/>	<input type="radio"/>	<input type="radio"/>	<input type="radio"/>	<input type="radio"/>	<input type="radio"/>	<input type="radio"/>	<input type="radio"/>	<input type="radio"/>	<input type="radio"/>	<input type="radio"/>	<input type="radio"/>	<input type="radio"/>
Onions	<input type="radio"/>	<input type="radio"/>	<input type="radio"/>	<input type="radio"/>	<input type="radio"/>	<input type="radio"/>	<input type="radio"/>	<input type="radio"/>	<input type="radio"/>	<input type="radio"/>	<input type="radio"/>	<input type="radio"/>	<input type="radio"/>
Apples	<input type="radio"/>	<input type="radio"/>	<input type="radio"/>	<input type="radio"/>	<input type="radio"/>	<input type="radio"/>	<input type="radio"/>	<input type="radio"/>	<input type="radio"/>	<input type="radio"/>	<input type="radio"/>	<input type="radio"/>	<input type="radio"/>
Citrus fruit	<input type="radio"/>	<input type="radio"/>	<input type="radio"/>	<input type="radio"/>	<input type="radio"/>	<input type="radio"/>	<input type="radio"/>	<input type="radio"/>	<input type="radio"/>	<input type="radio"/>	<input type="radio"/>	<input type="radio"/>	<input type="radio"/>
Bananas	<input type="radio"/>	<input type="radio"/>	<input type="radio"/>	<input type="radio"/>	<input type="radio"/>	<input type="radio"/>	<input type="radio"/>	<input type="radio"/>	<input type="radio"/>	<input type="radio"/>	<input type="radio"/>	<input type="radio"/>	<input type="radio"/>
Strawberries	<input type="radio"/>	<input type="radio"/>	<input type="radio"/>	<input type="radio"/>	<input type="radio"/>	<input type="radio"/>	<input type="radio"/>	<input type="radio"/>	<input type="radio"/>	<input type="radio"/>	<input type="radio"/>	<input type="radio"/>	<input type="radio"/>

	Shallow fry on stove	Deep fry	Roast or bake in the oven	Steam	Boil on the stove	Microwave	Toast, broil, or grill in the oven	Sous vide	In a slow cooker	In a pressure cooker	Use an electric grill (such as George Foreman)	I typically eat this food as purchased without further cooking	I do not eat this food
Milk	<input type="radio"/>	<input type="radio"/>	<input type="radio"/>	<input type="radio"/>	<input type="radio"/>	<input type="radio"/>	<input type="radio"/>	<input type="radio"/>	<input type="radio"/>	<input type="radio"/>	<input type="radio"/>	<input type="radio"/>	<input type="radio"/>
Cheese (full fat)	<input type="radio"/>	<input type="radio"/>	<input type="radio"/>	<input type="radio"/>	<input type="radio"/>	<input type="radio"/>	<input type="radio"/>	<input type="radio"/>	<input type="radio"/>	<input type="radio"/>	<input type="radio"/>	<input type="radio"/>	<input type="radio"/>
Cheese (reduced fat)	<input type="radio"/>	<input type="radio"/>	<input type="radio"/>	<input type="radio"/>	<input type="radio"/>	<input type="radio"/>	<input type="radio"/>	<input type="radio"/>	<input type="radio"/>	<input type="radio"/>	<input type="radio"/>	<input type="radio"/>	<input type="radio"/>
Eggs	<input type="radio"/>	<input type="radio"/>	<input type="radio"/>	<input type="radio"/>	<input type="radio"/>	<input type="radio"/>	<input type="radio"/>	<input type="radio"/>	<input type="radio"/>	<input type="radio"/>	<input type="radio"/>	<input type="radio"/>	<input type="radio"/>
Bacon	<input type="radio"/>	<input type="radio"/>	<input type="radio"/>	<input type="radio"/>	<input type="radio"/>	<input type="radio"/>	<input type="radio"/>	<input type="radio"/>	<input type="radio"/>	<input type="radio"/>	<input type="radio"/>	<input type="radio"/>	<input type="radio"/>
Beef	<input type="radio"/>	<input type="radio"/>	<input type="radio"/>	<input type="radio"/>	<input type="radio"/>	<input type="radio"/>	<input type="radio"/>	<input type="radio"/>	<input type="radio"/>	<input type="radio"/>	<input type="radio"/>	<input type="radio"/>	<input type="radio"/>
Lamb	<input type="radio"/>	<input type="radio"/>	<input type="radio"/>	<input type="radio"/>	<input type="radio"/>	<input type="radio"/>	<input type="radio"/>	<input type="radio"/>	<input type="radio"/>	<input type="radio"/>	<input type="radio"/>	<input type="radio"/>	<input type="radio"/>
Pork	<input type="radio"/>	<input type="radio"/>	<input type="radio"/>	<input type="radio"/>	<input type="radio"/>	<input type="radio"/>	<input type="radio"/>	<input type="radio"/>	<input type="radio"/>	<input type="radio"/>	<input type="radio"/>	<input type="radio"/>	<input type="radio"/>
Chicken	<input type="radio"/>	<input type="radio"/>	<input type="radio"/>	<input type="radio"/>	<input type="radio"/>	<input type="radio"/>	<input type="radio"/>	<input type="radio"/>	<input type="radio"/>	<input type="radio"/>	<input type="radio"/>	<input type="radio"/>	<input type="radio"/>
White fish	<input type="radio"/>	<input type="radio"/>	<input type="radio"/>	<input type="radio"/>	<input type="radio"/>	<input type="radio"/>	<input type="radio"/>	<input type="radio"/>	<input type="radio"/>	<input type="radio"/>	<input type="radio"/>	<input type="radio"/>	<input type="radio"/>
Oily fish (Salmon)	<input type="radio"/>	<input type="radio"/>	<input type="radio"/>	<input type="radio"/>	<input type="radio"/>	<input type="radio"/>	<input type="radio"/>	<input type="radio"/>	<input type="radio"/>	<input type="radio"/>	<input type="radio"/>	<input type="radio"/>	<input type="radio"/>
Beans or chickpeas (canned)	<input type="radio"/>	<input type="radio"/>	<input type="radio"/>	<input type="radio"/>	<input type="radio"/>	<input type="radio"/>	<input type="radio"/>	<input type="radio"/>	<input type="radio"/>	<input type="radio"/>	<input type="radio"/>	<input type="radio"/>	<input type="radio"/>
Baked beans	<input type="radio"/>	<input type="radio"/>	<input type="radio"/>	<input type="radio"/>	<input type="radio"/>	<input type="radio"/>	<input type="radio"/>	<input type="radio"/>	<input type="radio"/>	<input type="radio"/>	<input type="radio"/>	<input type="radio"/>	<input type="radio"/>
Soya meat or Quorn	<input type="radio"/>	<input type="radio"/>	<input type="radio"/>	<input type="radio"/>	<input type="radio"/>	<input type="radio"/>	<input type="radio"/>	<input type="radio"/>	<input type="radio"/>	<input type="radio"/>	<input type="radio"/>	<input type="radio"/>	<input type="radio"/>

According to your best guess, Please estimate how long (in minutes) it takes you to typically cook the foods listed below using your typical cooking method. If eaten raw please select "0".

Note: Cooking time does not include preparation. If the food takes longer than 120 minutes (2 hours) of cooking, please select "120". If the food is typically eaten with no cooking (i.e. raw) please select "0".

We will ask many people the same question about these foods , so don't worry if you aren't absolutely sure. Just give us your best guess.

	Minutes of cooking											
	0	12	24	36	48	60	72	84	96	108	120	
Pasta												<input type="text"/>
Rice												<input type="text"/>
Bread												<input type="text"/>
Breakfast cereal												<input type="text"/>
Potatoes												<input type="text"/>

Minutes of cooking

	0	12	24	36	48	60	72	84	96	108	
Carrots											<input type="text"/>
Tomatoes											<input type="text"/>
Frozen Peas											<input type="text"/>
Cabbages											<input type="text"/>
Cauliflowers											<input type="text"/>
Mushrooms											<input type="text"/>
Onions											<input type="text"/>
Apples											<input type="text"/>
Citrus fruit											<input type="text"/>
Bananas											<input type="text"/>
Strawberries											<input type="text"/>
Milk											<input type="text"/>
Cheese (full fat)											<input type="text"/>
Cheese (reduced fat)											<input type="text"/>
Eggs											<input type="text"/>
Bacon											<input type="text"/>
Beef											<input type="text"/>
Lamb											<input type="text"/>
Pork											<input type="text"/>

Minutes of cooking

	0	12	24	36	48	60	72	84	96	108	120	
Chicken												<input type="text"/>
White fish												<input type="text"/>
Oily fish (Salmon)												<input type="text"/>
Beans or chickpeas (canned)												<input type="text"/>
Baked beans												<input type="text"/>
Soya meat or Quorn												<input type="text"/>

Risk

According to your best guess, please rate how safe to eat the foods listed below are? i.e. how likely is it that eating them will damage your health due to risks such as contamination, food poisoning, improper handling, food fraud, mislabeling etc.

We will ask many people the same question about these foods , so don't worry if you aren't absolutely sure. Just give us your best guess.

	Low Risk						High Risk					
	0	1	2	3	4	5	6	7	8	9	10	
Pasta												<input type="text"/>
Rice												<input type="text"/>
Bread												<input type="text"/>
Breakfast cereal												<input type="text"/>
Potatoes												<input type="text"/>
Carrots												<input type="text"/>
Tomatoes												<input type="text"/>

	Low Risk						High Risk					
	0	1	2	3	4	5	6	7	8	9	1	
Frozen Peas												<input type="text"/>
Cabbages												<input type="text"/>
Cauliflowers												<input type="text"/>
Mushrooms												<input type="text"/>
Onions												<input type="text"/>
Apples												<input type="text"/>
Citrus fruit												<input type="text"/>
Bananas												<input type="text"/>
Strawberries												<input type="text"/>
Milk												<input type="text"/>
Cheese (full fat)												<input type="text"/>
Cheese (reduced fat)												<input type="text"/>
Eggs												<input type="text"/>
Bacon												<input type="text"/>
Beef												<input type="text"/>
Lamb												<input type="text"/>
Pork												<input type="text"/>
Chicken												<input type="text"/>
White fish												<input type="text"/>

	Low Risk						High Risk					
	0	1	2	3	4	5	6	7	8	9	10	
Oily fish (Salmon)												<input type="text"/>
Beans or chickpeas (canned)												<input type="text"/>
Baked beans												<input type="text"/>
Soya meat or Quorn												<input type="text"/>

Animal Welfare

According to your best guess, please rate how well animals are treated, and the quality in which they are kept to produce the foods listed below ? i.e. the quality of the conditions in which they are kept and how humanely they are slaughtered.

Please only select food categories related to animal welfare.

We will ask many people the same question about these foods , so don't worry if you aren't absolutely sure. Just give us your best guess.

	0 (not humane treatment, poor quality of living conditions)					10 (humane treatment, high quality of living conditions)						
	0	1	2	3	4	5	6	7	8	9	10	
Pasta												<input type="text"/>
Rice												<input type="text"/>
Bread												<input type="text"/>
Breakfast cereal												<input type="text"/>
Potatoes												<input type="text"/>
Carrots												<input type="text"/>
Tomatoes												<input type="text"/>
Frozen Peas												<input type="text"/>

0 (not humane treatment, poor quality of living conditions) 10 (humane treatment, high quality of living conditions)

	0	1	2	3	4	5	6	7	8	9	10	
Cabbages												<input type="text"/>
Cauliflowers												<input type="text"/>
Mushrooms												<input type="text"/>
Onions												<input type="text"/>
Apples												<input type="text"/>
Citrus fruit												<input type="text"/>
Bananas												<input type="text"/>
Strawberries												<input type="text"/>
Milk												<input type="text"/>
Cheese (full fat)												<input type="text"/>
Cheese (reduced fat)												<input type="text"/>
Eggs												<input type="text"/>
Bacon												<input type="text"/>
Beef												<input type="text"/>
Lamb												<input type="text"/>
Pork												<input type="text"/>
Chicken												<input type="text"/>
White fish												<input type="text"/>

0 (not humane treatment, poor quality of living conditions) 10 (humane treatment, high quality of living conditions)

	0	1	2	3	4	5	6	7	8	9	10	
Oily fish (Salmon)												<input type="text"/>
Beans eg kidney beans or chickpeas (canned)												<input type="text"/>
Baked beans												<input type="text"/>
Soya meat or Quorn												<input type="text"/>

Calories

According to your best guess, please estimate the Calories (kcal) contained in the food portions listed bel

For an image of the food portion, please click on the name of each food below.

A calorie is a unit that is used to measure energy. The Calorie you see on a food package is actually a “kilocalorie”, or 1,000 calories. A Calorie (kcal) is the amount of energy needed to raise the temperature of 1 kilogram of water 1 degree Celsius. The higher the number of Calories the greater the amount of energy in the food.

A portion of parsnips (~60g) contains 12.2 Calories (kcal)worth of energy. A chocolate bar (~50g) contains 240 Calories (kcal) worth of energy. A slice of ham (~23g) contains 240 Calories (kcal) worth of energy.

We will ask many people the same question about these foods , so don't worry if you aren' absolutely sure. Just give us your best guess.

	Low Calorie (kcal)						High Calorie (kcal)					
	0	100	200	300	400	500	600	700	800	900	1000	
Pasta (238g)												<input type="text"/>
Rice (258g)												<input type="text"/>
Bread (100g)												<input type="text"/>
Breakfast cereal (52g)												<input type="text"/>
Potatoes (213g)												<input type="text"/>

	Low Calorie (kcal)							High Calorie (kcal)				
	0	100	200	300	400	500	600	700	800	900	10	
Carrots (82g)												<input type="text"/>
Tomatoes (92g)												<input type="text"/>
Frozen Peas (75g)												<input type="text"/>
Cabbages (92g)												<input type="text"/>
Cauliflowers (128g)												<input type="text"/>
Mushrooms (62g)												<input type="text"/>
Onions (59g)												<input type="text"/>
Apples (141g)												<input type="text"/>
Orange (263g)												<input type="text"/>
Bananas (137g)												<input type="text"/>
Strawberries (105g)												<input type="text"/>
Milk (68g)												<input type="text"/>
Cheese (full fat, 52g)												<input type="text"/>
Cheese (reduced fat, 52g)												<input type="text"/>
Eggs (121g)												<input type="text"/>
Bacon (61g)												<input type="text"/>
Beef (140g)												<input type="text"/>
Lamb (139g)												<input type="text"/>

	Low Calorie (kcal)							High Calorie (kcal)				
	0	100	200	300	400	500	600	700	800	900	1000	
Pork (238g)												<input type="text"/>
Chicken (112g)												<input type="text"/>
White fish (134g)												<input type="text"/>
Oily fish (Salmon, 134g)												<input type="text"/>
Beans or chickpeas (canned,95g)												<input type="text"/>
Baked beans (233g)												<input type="text"/>
Soya meat or Quorn (105g)												<input type="text"/>

Carbon Footprint

According to your best guess, please estimate the carbon footprint (grams of CO2) embodied in the food portions listed below.

For an image of the food portion, please click on the name of each food below

Food’s carbon footprint, or foodprint, is the greenhouse gas emissions per gramme of product produced by growing, rearing, farming, processing, transporting, storing, cooking and disposing of the food you eat. We are measuring greenhouse gas emissions in grams of carbon dioxide (CO2) per grams of product. The higher the carbon footprint the more environmental damage.

A portion of parsnips (~60g) has a carbon footprint of ~200g of CO2. A chocolate bar (~50g) has a carbon footprint of ~900g of CO2. A slice of ham (~23g) has a carbon footprint of ~1500g of CO2.

We will ask many people the same question about these foods , so don't worry if you aren' absolutely sure. Just give us your best guess.

	Low carbon footprint (g of CO2)					High carbon footprint (g of CO2)						
	0	818	1636	2454	3272	4090	4908	5726	6544	7362		8180
Pasta (238g)												<input type="text"/>

Low carbon footprint (g of CO2)

High carbon footprint (g of CO2)

0 818 1636 2454 3272 4090 4908 5726 6544 7362 8180

	0	818	1636	2454	3272	4090	4908	5726	6544	7362	8180	
Rice (258g)												<input type="text"/>
Bread (100g)												<input type="text"/>
Breakfast cereal (52g)												<input type="text"/>
Potatoes (213g)												<input type="text"/>
Carrots (82g)												<input type="text"/>
Tomatoes (92g)												<input type="text"/>
Frozen Peas (75g)												<input type="text"/>
Cabbages (92g)												<input type="text"/>
Cauliflowers (128g)												<input type="text"/>
Mushrooms (62g)												<input type="text"/>
Onions (59g)												<input type="text"/>
Apples (141g)												<input type="text"/>
Orange (263g)												<input type="text"/>
Bananas (137g)												<input type="text"/>
Strawberries (105g)												<input type="text"/>
Milk (68g)												<input type="text"/>
Cheese (full fat, 52g)												<input type="text"/>
Cheese (reduced fat, 52g)												<input type="text"/>

	Low carbon footprint (g of CO2)					High carbon footprint (g of CO2)						
	0	818	1636	2454	3272	4090	4908	5726	6544	7362		8180
Eggs (121g)												<input type="text"/>
Bacon (61g)												<input type="text"/>
Beef (140g)												<input type="text"/>
Lamb (139g)												<input type="text"/>
Pork (238g)												<input type="text"/>
Chicken (112g)												<input type="text"/>
White fish (134g)												<input type="text"/>
Oily fish (Salmon, 134g)												<input type="text"/>
Beans or chickpeas (canned, 95g)												<input type="text"/>
Baked beans (233g)												<input type="text"/>
Soya meat or Quorn (105g)												<input type="text"/>

Block 10

Prolific ID:

End

Thank you for participating in the survey.

If you have any queries please contact Lead Researcher for the University of Sheffield: Christian Reynolds (c.reynolds@sheffield.ac.uk)

You should automatically be redirected back to Prolific. If this does not happen use the completion code: 4E0F43DA

