



# The utilisation of useful ambient energy in residential dwellings to improve thermal comfort and reduce energy consumption

Magdi Rashad, Navid Khordehghah, Alina Żabnieńska-Góra, Lujean Ahmad, Hussam Jouhara\*

Heat Pipe and Thermal Management Research Group, College of Engineering, Design and Physical Sciences, Brunel University London, UB8 3PH, UK

## ARTICLE INFO

### Article History:

Received 7 October 2020

Revised 11 November 2020

Accepted 25 November 2020

Available online 9 December 2020

### Keywords:

Free ambient energy

Residential buildings

Comfort conditions

HVAC

Heat pipes

Indirect evaporative cooling, Solar PV/T

## ABSTRACT

Energy consumption in the housing sector, is significantly high and continues to escalate. Urbanisation due to population growth and migration from rural areas to cities are two main reasons for this rising demand. With the uncertainty in the energy market and the increasing awareness of the impact of fossil fuels on the environment, research work in efficient building design has gained momentum. Energy conservation guidelines in many countries have become mandatory. However, more emphasis has been given to commercial, institutional, governmental and industrial buildings, which commonly employ more efficient HVAC systems than those deployed in houses. Thus, the push towards energy conservation in the residential sector is less noticeable. This is further compounded with the absence of will power to enforce the same energy conservation rules as the case with other sectors. In this paper five passive cooling and heating strategies have been reviewed (passive building design, night ventilation, nocturnal cooling, PCM (Phase Change Material) and IEC (Indirect Evaporative Cooling), solar thermal energy). The aim is to evaluate how to implement them better in a cost-effective way in existing and new houses. The literature review confirmed the need for further investigation of energy efficient HVAC systems with passives strategies solutions for contemporary residential dwellings is required to make a meaningful impact on the energy map of this sector. Also, the viability of an easy to deploy and configure HVAC system for retrofit and new applications for more benefits of these passive strategies either individually or in a hybrid configuration needs to be explored.

© 2020 The Author(s). Published by Elsevier Ltd. This is an open access article under the CC BY license (<http://creativecommons.org/licenses/by/4.0/>)

## Acronym

- BOE: Barrel of Oil Equivalent
- COP: Coefficient of Performance
- FCS: Free Cooling System
- GCC: Gulf Cooperation Council
- HVAC: Heating Ventilation and Air Conditioning
- IEC: Indirect Evaporative Cooling
- KWc: Kilowatt Cooling
- KWe: Kilowatt Electric
- MWc: Megawatt Cooling
- MWe: Megawatt Electric
- MWh: Megawatt Hour
- PV: Photovoltaic
- PV/T: Photovoltaic/Thermal
- RH: Relative Humidity

## 1. Introduction

The ever-growing demand for electricity and gas for air conditioning (cooling and heating) in residential buildings, the uncertainty in the energy market over the last 30 years and the growing awareness of the impact fossils fuels have on the environment are the driving force behind the increasing research interest in finding ways to reduce residential buildings footprint. This drive is gaining traction in both developed and developing nations, including those who rely heavily on oil exports as the only or main source of revenue. Dermot Gately et al. reported that the domestic oil consumption in 2012 in KSA (Kingdom of Saudi Arabia) reached nearly 3 million barrels per day with an estimated annual growth rate of 5.7% [1,2]. The figure is around 4 million barrels today as reported by CEICDATA [3]. This number is likely to double over the next 10 years if the current rate of increase in electricity demand continues, the estimated annual increase being 5 % to 7% [2], with approximately 40% of this oil used to generate electricity [4]. The estimated electricity consumption in the residential sector in Kuwait is 60% of the total national power generated, particularly during peak summer months because of air conditioning [5]. This is a repeated scenario in the GCC (Gulf Cooperation Council) where temperatures can reach 50 °C or above in

\* Corresponding author.

E-mail address: [hussam.jouhara@brunel.ac.uk](mailto:hussam.jouhara@brunel.ac.uk) (H. Jouhara).

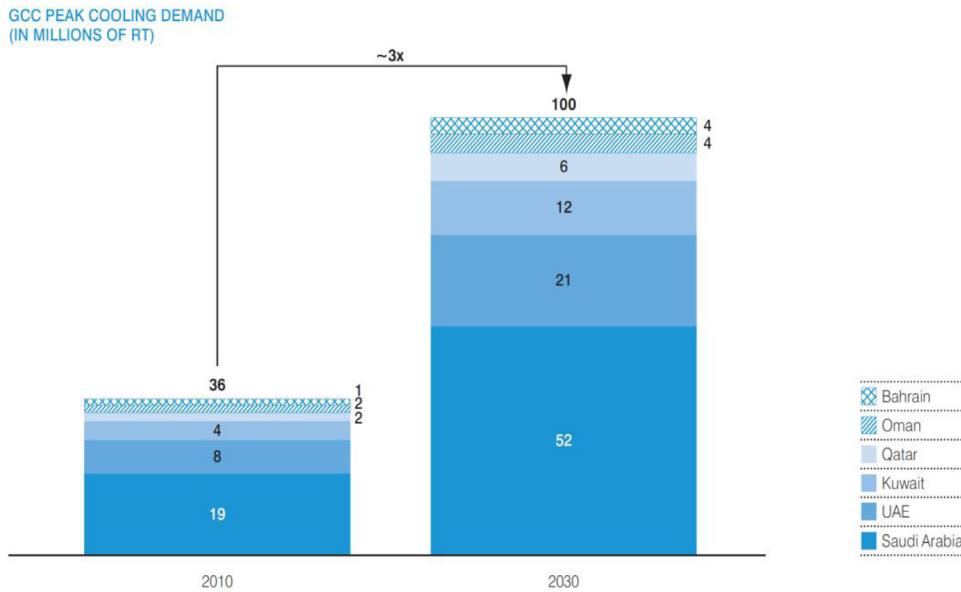

Fig. 1. GCC PEAK COOLING DEMAND in Millions of Refrigeration Ton [9].

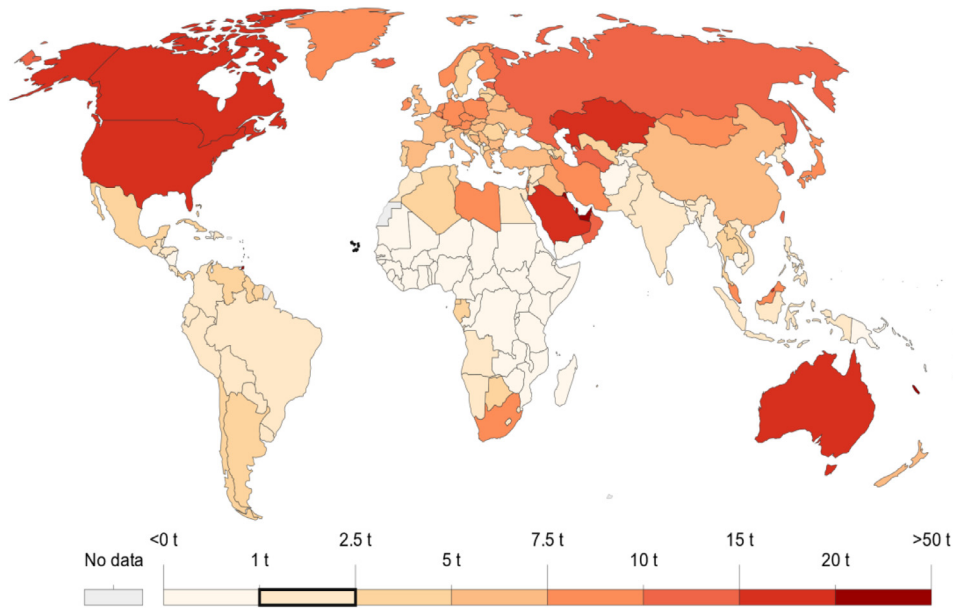

Fig. 2. Average carbon dioxide (CO<sub>2</sub>) emissions per capita measured in tonnes per year. 2018 [12].

summer. In Kuwait on 16<sup>th</sup> July 2016 a record peak day time temperature of 53.9 °C was recorded [6], while temperatures of 50 °C plus are a common occurrence in other cities such as Riyadh and Baghdad. While the cost of building power plants and transmission lines is in the region of £1.5 million per MWe [7], the cost of air conditioning is in the range of £50,000 to £100,000 per MWh [8] depending on the type of system i.e. central or unitary. Mechanical cooling (using refrigeration) is an expensive necessity in the GCC. Fig. 1 shows the demand for cooling in millions of RT (RT = Refrigeration Ton = 3.515 kWc) in 2010 and how it is expected to be in 2030 [9].

It is estimated that one MWh (Megawatt hour) of electricity requires 1.71 BOE (Barrel of Oil Equivalent) to burn [10] and each BOE results in the formation and emission of 390 kg of CO<sub>2</sub> approximately [11]. The GCC along with many other countries where air conditioning is a necessity are among the highest contributors of GHG (Green House Gases). Fig. 2 shows the CO<sub>2</sub> emission per capita in 2011 [12]. Table 1 illustrates the average annual energy consumption, estimated Barrel of Oil Equivalent and CO<sub>2</sub> emissions in a few

countries [13]. Most of these countries are in the 53% glocable emissions red zone according to “http://OurWorldinData.org/co2-emissions”

Temperatures are less extreme in tropical regions, but humidity tends to be higher and the warm season is longer or all year round. High humidity requires dehumidification, this is typically done either

Table 1  
Annual average electricity consumption & CO<sub>2</sub> emission in some countries [13].

| Country  | Population  | Average Electricity Consumption (MWh/Year/Country) | Average BOE/Year | CO <sub>2</sub> Emission Ton/Year |
|----------|-------------|--|------------------|-----------------------------------|
| Egypt    | 94,666,993  | 142,947,159  | 228,715,454      | 68,614,636                        |
| Pakistan | 211,995,540 | 85,858,194   | 137,373,110      | 41,211,933                        |
| Greece   | 10,773,253  | 52,993,632   | 84,789,811       | 25,436,943                        |
| Jordan   | 8,185,384   | 15,994,240   | 25,590,784       | 7,677,235                         |
| Lebanon  | 6,237,738   | 15,999,798   | 25,599,676       | 7,679,903                         |

by subcooling the room air to saturation conditions as it passes through the cooling coils in the air handling or fan coil units and then by re-heating back to the normal supply air temperature, or by desiccant dehumidification, which requires regeneration, to remove excessive moisture. Both solutions lead to more energy expenditure.

In winter, space heating is essential in many countries. In Kuwait and the northern parts of Pakistan, for example, the yearly range (the difference between the highest and lowest temperatures) is 35–45 degrees Celsius [6], also, it is quite common to see temperatures tumble down to near zero at night and during the early hours of the morning. The Northern Region of Saudi Arabia and parts of Jordan, Syria and Lebanon have frequently experienced heavy snowfall during winter in recent years.

Passive cooling building design is gaining momentum through the necessity of improving the thermal performance of buildings and reducing their carbon footprint by increasing reliance on renewable energies. However, commercial buildings (6 floors and above), shopping malls, institutional and government buildings have received the lionshare of these studies and the attention of public and private sectors, particularly those recently constructed. Existing commercial buildings have benefited from the vast experience gained and accumulated knowledge in sustainability as well as the viability of conducting and implementing the findings of energy audits. While commercial buildings, which are normally equipped with relatively more efficient HVAC systems and benefit from a wider diversity of cooling and heating loads (as high as 60% in the case of cooling) due to size and occupancy patterns, receive more attention, residential buildings (below 6 floors) and housing units (detached, semidetached villas and town houses) do not receive enough attention or practical incentives to improve their energy ratings as commonly seen in UK and Europe. In addition, most of these residential constructions are equipped with the least efficient cooling equipment such as window type air conditioners, mini-split, VRF (Variable Refrigerant Flow), package/split DX (Direct Expansion) and air-cooled chillers [14]. In contrast, commercial buildings are normally equipped with far more efficient cooling equipment such as water-cooled chillers or receive chilled water as a utility from town scale district cooling schemes. The problem is further compounded with the electricity consumption characteristic which tends to be more residential than commercial. In Kuwait, for example, up to 60% of the electricity consumption is in the residential sector [15–18]. Similar electricity consumption characteristics can be found in the rest of the GCC and the MENA Region. In Saudi Arabia, the existing low-rise building stock is around 1.5 Million units with a shortage of nearly 500 thousand; similar order of magnitude numbers can be found in other countries such as Pakistan and Egypt.

Considerable research work has been carried out using a variety of passive energy saving strategies, either individually or in a hybrid configuration of more than one strategy. This research review paper looks at the state of the art of some of these strategies which have exhibited some degree of success with the intention of finding research gaps for further work. The aim is to evaluate how to implement them better in a cost-effective way in existing and new buildings.

Passive energy strategies considered:

- Passive building design.
- Night ventilation: the use of night-time ambient air when its temperature drops below a certain threshold by inducing it into buildings.
- Nocturnal cooling: night sky radiation exchange with building surfaces as well as cooling media such as water.
- PCM (Phase Change Material) and IEC (Indirect Evaporative Cooling): use of phase change material to increase the sensible cooling efficiency of evaporative coolers and use of water as a cooling medium whereby air is induced into the evaporative cooler

through a controlled spray of water to lower its DBT (Dry Bulb Temperature) when ambient air conditions permit.

- Solar thermal energy.

## 2. Passive building design

The concept of a “house” evolved in the history of mankind through a process of trial and error motivated mainly by having to shelter from the climate adversity and for safety and security. From the humble beginnings of a temporary or permanent shelter (tree, cave, overhang, etc.) houses evolved to today’s complex mechanized buildings, not only protecting from the weather but also creating specific indoor conditions to meet specific needs all year round. Even the concept of indoor comfort itself changed with time from the basic need to keep dry, warm or cold to being accustomed to precise temperature, humidity and air quality conditions. People have become sensitive to the slightest variation in temperature and humidity, while the natural ability to climatize between the different weather patterns diminished, i.e. at the beginning of summer there is a tendency to feel warmer at lower temperatures while at the beginning of winter the tendency is to feel colder at higher temperatures. Also, social as well as clothing habits have added to the higher demand for better controlled indoor thermal conditions. All this led to the relentless rise in domestic energy demand compounded further with population increase and the need to house more people.

The growing awareness of the energy efficiency features of the historical vernacular architecture led to many researchers look closely how they work and how they can adopt them to help improve the prospective energy requirements of contemporary architecture with the use of modern construction materials. Abdulkareem [19] correctly stated that “Dwellings are built to serve a variety of functions, but one of the most important is to create living conditions that are acceptable to their occupiers particularly in relation to the prevailing climates”.

One of the outstanding examples of a successful historical traditional built form is the courtyard house. Many examples can be seen across the globe from China to the Indian Subcontinent, the Middle East, North Africa, southern Europe and Latin America. This was a successful example of how man learned to couple his complex needs for a shelter by building for and in harmony with the environment. As referred to by the same author in his paper [19], “The creation of shelter is our response to the environment and the context of our existence, which consists of a complex set of components.” This form of house topography can be seen in its basic form as a simple house with a few rooms surrounding an open space (courtyard) as well as in much more complex and sophisticated forms of palaces, forts, temples, churches and mosques. While the best way to save energy is not to use it at all, which obviously is an impractical proposition, the courtyard house tends to score high on the scale of free ambient energy utilisation. It has many built-in passive energy measures, one of which is its fundamental principle of the open space right in the core of the house (the courtyard) and its ability to efficiently exchange energy with the night sky in what is known as nocturnal radiation exchange. The night sky absorbs the radiant energy emitted from the house walls, roof and courtyard surfaces, which was received the previous day. This results in these construction surfaces cooling down, the air in the courtyard also, and in addition some of the cooler denser air from the roof of the house sinks and collects in the courtyard. The cold air seeps into the living accommodation surrounding the courtyard during the early hours of the morning keeping it relatively cooler than outside the house a little longer during the day, before the cycle repeats itself. Fig. 3 shows the actual temperature measurements taken in a courtyard house in Baghdad in the early 1970’s. Other fundamental principles of the courtyard house are the minimal fenestrations on external walls, which reduce solar

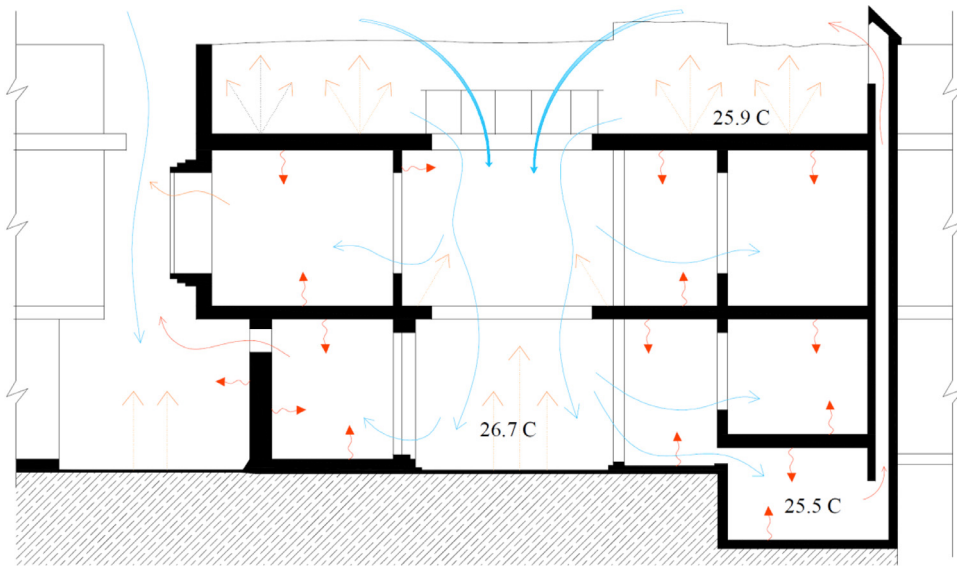

Fig. 3. Thermal performance of a courtyard house during the night in Baghdad [19].

Note: the measurements are effective temperatures that were recorded in a Baghdadi courtyard house in August 1972.

gains as well as the infiltration of warm ambient air, the high thermal mass of external walls, which increases the lag time between the maximum external and internal dry bulb temperatures, controlled ventilation openings at roof level (known as Badgir), which allow the cooler night air to be transported directly into the living accommodation through masonry channels in the thick walls.

Further enhancement to the indoor thermal comfort of the house was achieved by installing a fountain or ornamental water pools in the courtyard as well as vegetation. Obviously, the social movements shown in Fig. 4 and dress habits helped, for example, the Clo factor (clothes thermal insulation) of the traditional Arab garment known as dishdashaha or Jalabiya is less than half as much as for a typical light suit or shirt and trousers. Also what helped was the tendency of occupants to accept indoor thermal conditions which may be perceived in our time as outside the typical comfort range of 16°C to 28°C [20].

Other examples of passive design elements of traditional vernacular architecture, which help reduce heat gains and/or losses:

Construction materials: natural stone, mud bricks and wood. These basic natural materials, characterised by high thermal resistance, which delays heat transfer through the building envelope, were extensively used in the pre-cement era.

Mashrabiya in the Middle East: allows day light to cascade through the living accommodation as well as natural ventilation air but prevents glare and excessive direct sunshine, see Figs. 5 and 6. Sometimes porous clay pots filled with water are placed by the Mashrabiya to promote additional cooling through evaporation of the water that oozes out through the porous skin of the pot, keeping the outside surface wet and at the same time cooling down the rest of the water inside the pot for consumption [21].

Wind catchers (Badgir): induce ambient air naturally into the living space. This is done through a masonry shaft constructed from high thermal mass materials. The shaft traverses the full height of the building and rises above the roof level by several metres. As the relatively cooler air is induced into the building the warmer is purged out. It used to be quite popular in warm climates, particularly the Middle East [22].

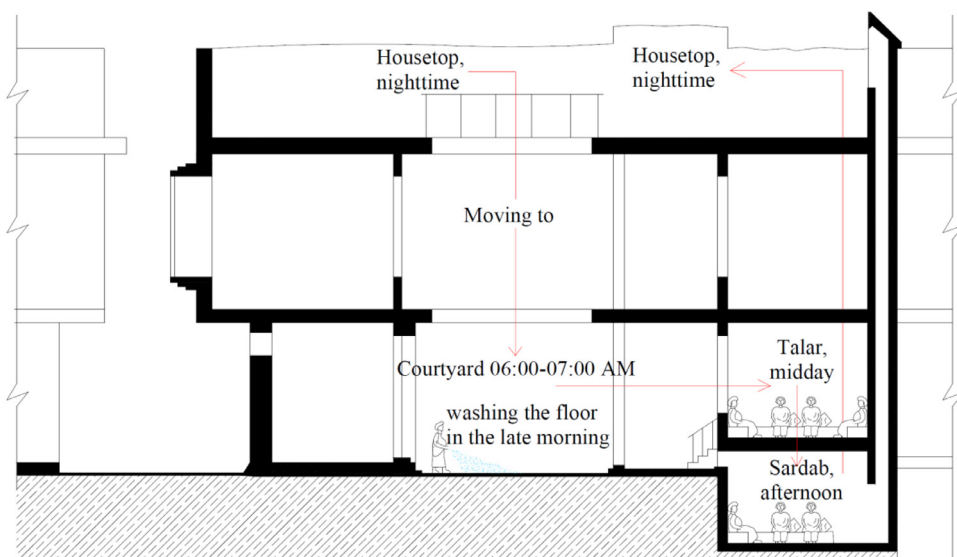

Fig. 4. Section of courtyard house, illustrating daily movement in the summer period [19].



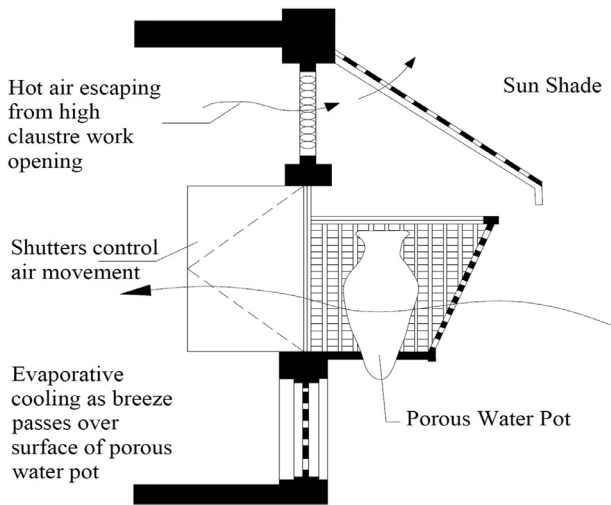

Fig. 5. Section illustrates integrating window with porous water Haval [19].

Zamani et al. [23] highlighted the sustainability aspects of the courtyard and how it can passively improve the thermal and micro-climatic conditions, particularly in hot arid climates, and the need to accurately identify the influential factors which determine its thermal performance. The researchers looked at how the courtyard configuration and components in terms of geometry, construction material, proportion, orientation, shading elements, vegetation and water features can be utilized to improve the thermal performance of the courtyard in the context of solar gain, humidity and natural air movement.

However, it is important to point out that, with the climate changes experienced in our time and the commonly unclear night skies due to pollution, the very fundamental principles by which the courtyard as well as exposed surfaces such as roofs cool down at night, through the exchange of longwave radiation with the night sky, has been inhibited (the night sky acts as a black body). The research highlights the importance of shading elements to reduce solar gains, a valid argument but only during day time as the same elements will inhibit the ability of the courtyard to effectively exchange radiation with the night sky. Therefore, it is important to study the use of shading elements that can be deployed during the day and retracted during the night. The researchers highlighted the importance of natural ventilation and how it can be affected by the geometrical configuration of the courtyard, i.e. ratio of height to floor

area and shape, and how it affects the thermal performance of the courtyard. While natural air movement may be desirable during mild/cool seasons, during the warmer season, it is best if it is encouraged at night, when the air temperature is lower, as the day time air temperature in hot arid climates can be excessively high.

Chen et al. [14], Song [15] and Gong et al. [16] highlight that typical passive design features, which would significantly impact building energy consumption, include layout, building fabric thermophysics and the extent to which buildings are airtight to minimise infiltration and/or exfiltration. In addition, building geometry plays a very important role in reducing envelope gains; for example, a circular building will have the least envelope area when compared with other building shapes with the same floor area, but circular buildings are not usually functionally practical. Also, the following are important: the ratio of window areas to wall areas, external wall and roof colours (lighter colours reduce thermal heat absorption), architectural shading elements, particularly on the south elevation in the northern hemisphere, as well as vegetation around buildings. Chen et al. [14] conclude that considering as many passive design measures as possible early in the design stage will help in energy optimization.

Dan et al. [25] stated that a passively designed house can generate improved indoor comfort with low energy consumption. A study was conducted on an energy efficient house in which passive energy measures were applied, such as extensive thermal insulation (polystyrene panel thermal insulation of thickness 300 mm in walls and 425 mm in the roof were used), advantageous orientation, heat recovery, and an air-tight envelope. The house was monitored for an extended period of time (2 years) and its design parameters and the results from monitoring were compared with those of a conventional house designed in accordance with the Romanian energy efficiency requirements. The measures applied to the passively designed house have resulted in a significant reduction in the energy consumption. It achieved a target of 15 kWh/m<sup>2</sup> year cooling/heating demand and a total primary energy requirement of less than 120 kWh/m<sup>2</sup> year.

Zune et al. [26] highlighted in a study of vernacular architectural houses in Myanmar from a thermal performance perspective, that traditional passive design is not enough to achieve indoor thermal comfort due to the noticeable changes in the climate as a result of global warming. Further studies are needed to focus on exploring new ideas which will help mitigate the additional challenges brought about by climate change.

Zaki et al. [27] simulated two hypothetical terraced houses, a conventional traditional Malaysian terraced house and another in which passive architectural strategies were implemented. The aim was to explore ways of improving the thermal performance by adapting

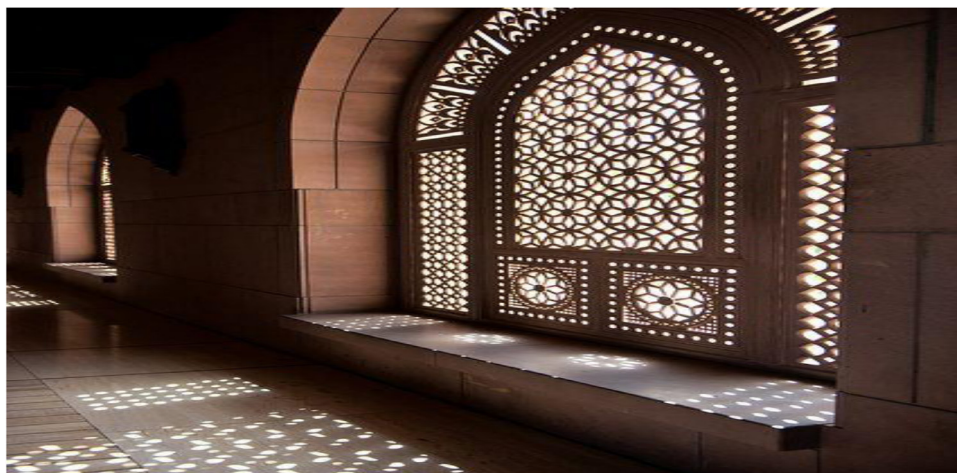

Fig. 6. Mashrabiya façade as seen from inside the living space.

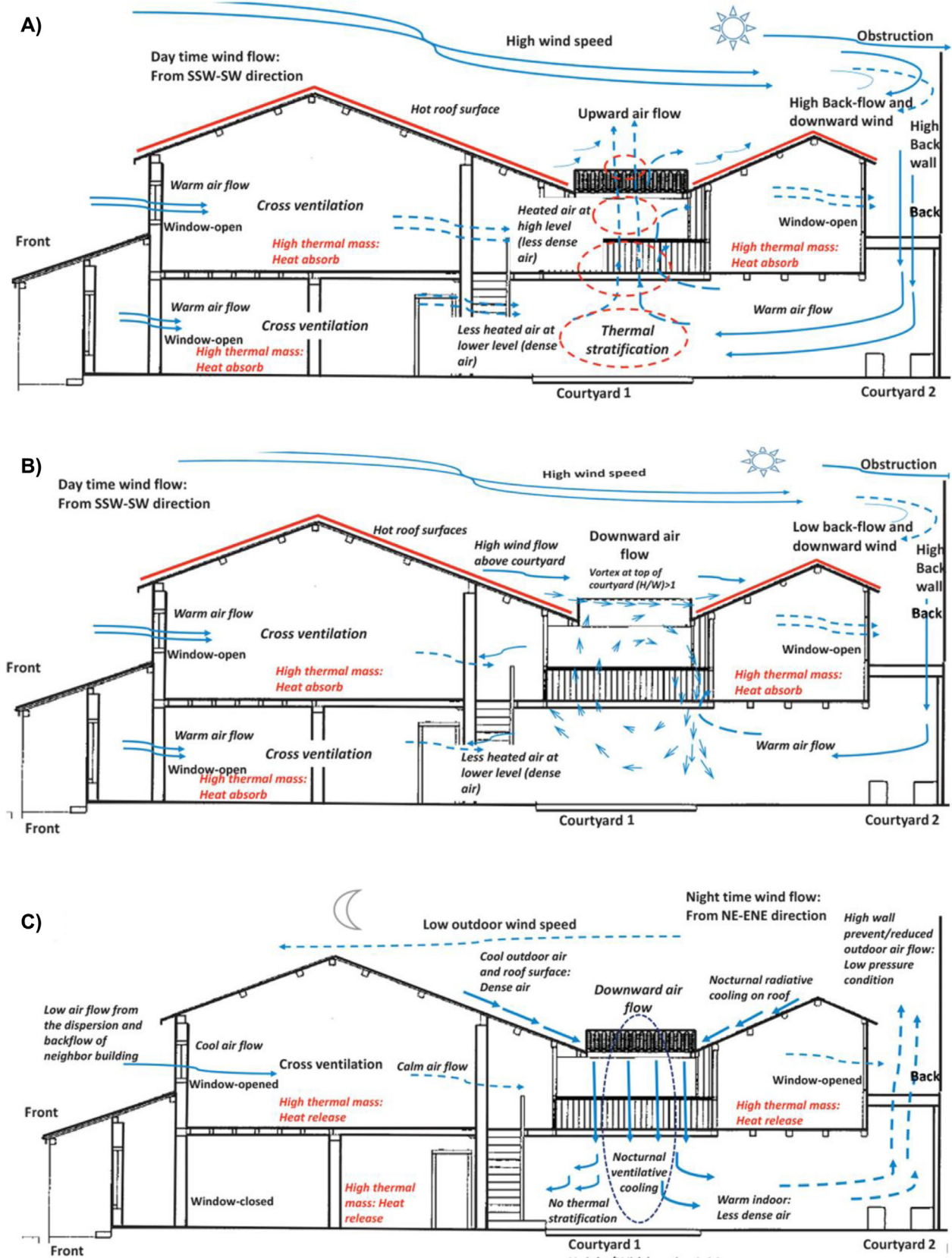

Fig. 7. The schematic air flow patterns of traditional house in Malaysia [23,24].

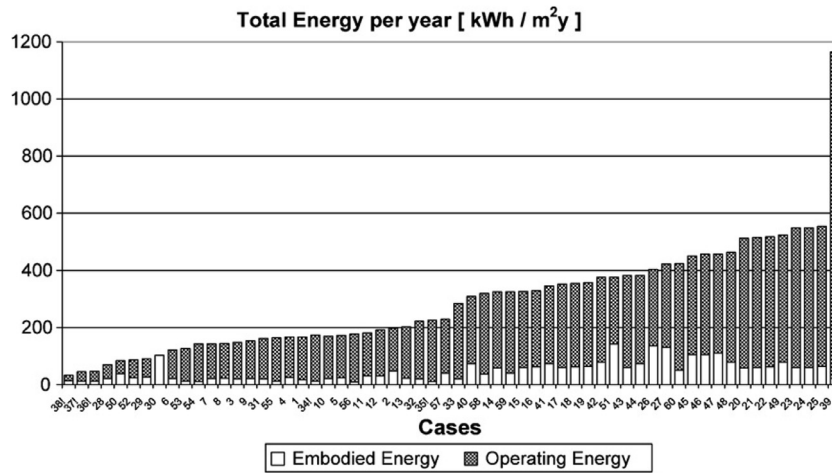

Fig. 8. Normalized total energy for the 60 cases [28].

passive measures such as more appropriate orientation, thermal insulation, particularly in the roof, larger windows and adequate shading devices. The simulation work revealed that significant improvements in the indoor thermal comfort can be achieved.

Sartori et al. [28] conducted a literature survey on the life cycle energy use of 60 buildings from 9 different countries. Two interesting findings emerged: a passively designed house outperformed an equivalent self-sufficient solar house in terms of energy efficiency and reduced the life cycle energy demand by a factor of 3 as well. The study also highlighted that operation represents the greater proportion of the total life-cycle energy consumption in conventional buildings, up to 90% to 95%, while the remainder represents the energy expended (embodied energy) in the manufacturing of construction materials, see Fig. 8.

Wang et al. [29] in their simulation of a number of passive heating and cooling strategies, such as energy recovery ventilation (heating and cooling), pre-heating/cooling fresh air, pre-ventilation and night ventilation, in different weather conditions in passive buildings, found that it is quite possible to combine energy efficiency and acceptable indoor conditions.

Roslan et al. [30] suggest that it is possible to maintain indoor thermal comfort all day long by minimizing the heat transfer through the building envelope, particularly the roof, as well as by removing internal hot air in hot humid regions. Taking into consideration the building orientation and local weather conditions, a reflective cool roof with an optimised pitch along with the ventilated roof can be introduced as design guidelines to help in improving the thermal performance of passively designed modern houses, Fig. 9.

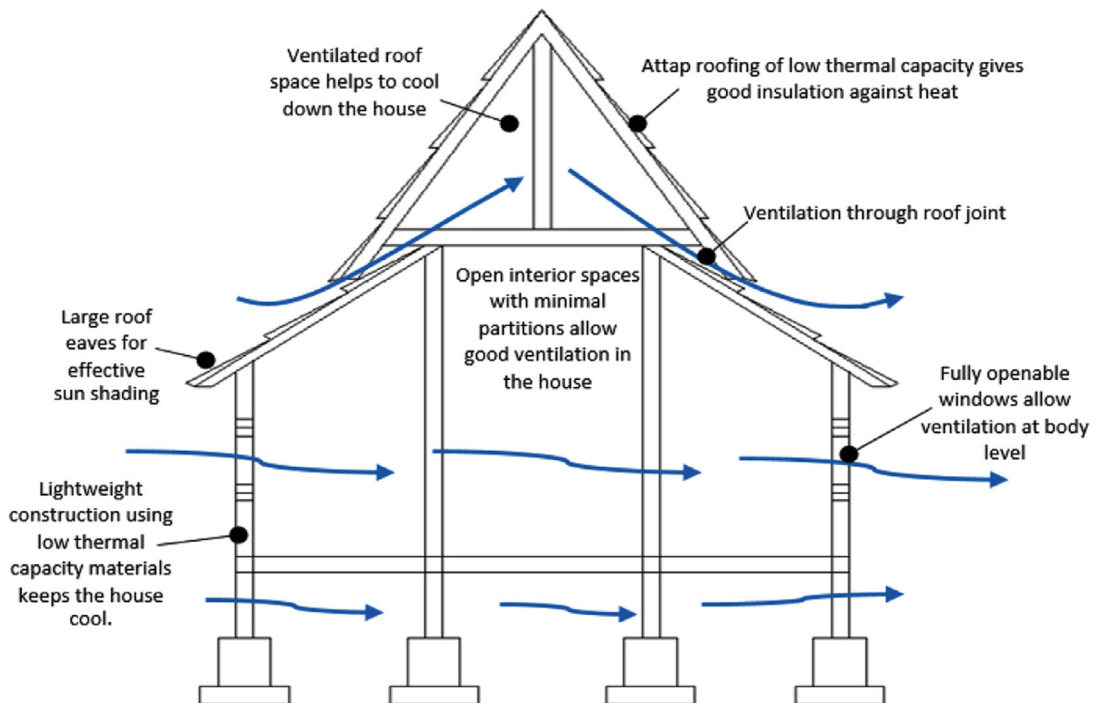

Fig. 9. Air movement for traditional Malay house. Source: The traditional Malay house, rediscovering Malaysia's indigenous shelter system [30].



### 3. Night ventilation (NV)

Night ventilation is the utilization of the nocturnal cooler air to drive down the temperatures of the building's internal air and surfaces (walls, floor, ceiling) to aid in cooling indoor spaces during the day in summer.

Ebrahim Solgi et al. [31] defines night ventilation as "... an effective passive cooling technique whereby the daytime heat gain of a building is released during the night through the intake of the cooler outdoor air." Air is induced into the building either naturally or mechanically through apertures in the building envelope, windows and/or dedicated ventilation openings. Depending on the thermal mass of the building, orientation, façade design, shading elements, particularly on the south elevation in the northern hemisphere and the adjacent external landscape, the effect of the nocturnal cooling will help increase the time lag between maximum external and indoor temperatures. According to the same source the longer the time lag, the lesser the number of hours needed to run the air conditioning, or to have to run the air conditioning at full load, particularly during peak summer hours, to maintain indoor comfort. Also, it is concluded that there is enough evidence to suggest that night ventilation strategies can be applied to most climate types but there is a need for optimization as well as integrating this passive energy solution with other passive strategies for more effective results, for example, indirect evaporative cooling and nocturnal radiation exchange. With climate change and the apparent evidence of globe warming [32], the fundamental parameters which govern the effectiveness of night ventilation, that is the diurnal range (maximum difference between the peak day time and minimum night time temperatures) and the duration of the lower night time temperatures, are not as common as before. Narrower diurnal ranges and shorter durations of lower night-time temperatures are more frequently experienced in regions expected to make full use of night time ventilation. It is quite evident that night ventilation on its own as a passive strategy may not necessarily yield the expected results and further research work needs to be conducted to optimise the use of this very important passive energy strategy.

As reported by Michael et al. [33] in a study on natural ventilation for cooling in a vernacular architectural building with high thermal mass in Cyprus, the maximum benefit can be achieved from cross ventilation at night. However, as the duration of the field measurement was limited to 27 days (7<sup>th</sup> July to 2<sup>nd</sup> August 2105), field measurements spanning a longer period, particularly during peak months, are recommended for more substantiated findings. This would allow more accurate measurements as well, by giving more time for the building to stabilise thermally between the various ventilation regimes adopted in the study i.e. (1) No Ventilation, (2) 24-hour ventilation, (3) Night Time Ventilation (21:00 to 07:00) and (4) Day Time Ventilation (07:00 to 21:00).

According to Giovanni [34], indoor thermal conditions can improve in an external temperature range of 28 °C to 32 °C with an indoor air movement of 1.5 m/s to 2 m/s. According to the same source, maximum benefits can be realised from night time ventilation when the nocturnal air temperature is around 20 °C and the diurnal day fluctuation is more than 10 °C. More studies are needed particularly on contemporary passively designed buildings with common construction materials, which would make up for the desired high thermal mass found in vernacular buildings, e.g. composite external wall and roof structures with thermal insulation, high emissivity light colours to reflect solar heat and double glazing.

Aste et al. [35] studied how well thermally insulated buildings will perform under the influence of the thermal inertia of external walls. The U value (Overall Heat Transfer Coefficient) should be in accordance with the international and local recognized energy conservation codes, e.g. in England – Wall 0.16 W/m<sup>2</sup>K, Floor 0.11 W/m<sup>2</sup>K and Roof 0.11 W/m<sup>2</sup>K [36,37].

Kubpta et al. [38] and Jamaludin et al. [39] investigated different ventilation strategies and their impact on indoor conditions in residential buildings. Both concluded that night time ventilation performed better than day time or full day ventilation.

Kololotrone et al. [40] concludes that night ventilation would be considered successful if the peak and average indoor temperatures are reduced the following day.

Taleb [41] refers to the Wind Catchers in Dubai encouraging natural cross ventilation, particularly at night, a common vernacular architecture in many areas in the Gulf Region and Iran long before mechanical cooling had become readily available. Wind Catchers may have offered some thermal relief to occupants at a time when the perception about indoor comfort was totally different to that today. Careful consideration must be given particularly with the noticeable changes in the climate where higher day time temperatures and a narrower diurnal range are quite common. In addition, the increased dust storms, which demand effective filtration of external air prior to induction into the living spaces, would significantly inhibit natural ventilation. There is not enough evidence in the article to support the benefits of wind catchers. The researcher describes the UAE climate, particularly in Dubai, as predominantly arid with sufficiently low night time air temperatures to make night time ventilation effective with the help of Wind Catchers. Dubai is a coastal city at the northern part of the UAE with a seafront to the West/North West of the City. The prevailing wind direction in the Gulf Region is mostly North-Westerly coming from the Saudi Arabian/Iraq desert. During the warm season, the wind heats as it passes over the desert, increasing the capacity of the air to pick up moisture from the Gulf as it traverses the coastal cities on the eastern part of the Arabian Peninsula. This is one of the main reasons why most of the Western Gulf Coast Cities south of Kuwait i.e. Jubail, Dharan / Khober, Doha, Manama, Abu Dhabi and Dubai, tend to be hotter and more humid than arid. Dubai itself receives the lion's share of this humid air as it faces the Gulf from the North and North West as well as the Arabian Sea from East and South East, making it even more prone to humidity when the wind changes direction at the end of the warm season. The researcher suggests a 23.6% saving in energy if the passive strategies considered in the research paper are applied [42]. The basis on which this saving was calculated is not clear. Also, there is no evidence that the thermal performance of the experimental house was recorded before any of the various passive strategies discussed in the article were applied, including the Wind Catcher.

Blondeau et al. [43] conclude that night ventilation has significant potential on its own to improve indoor thermal conditions and not necessarily the same potential can be realised by coupling night ventilation with other ventilation modes i.e. all day and day time. They also highlighted that further research work needs to be carried out to understand how night ventilation would affect the whole building and not just the restricted experimental space within the building which was under investigation. While night ventilation as a passive strategy has great potential, it may on its own improve indoor thermal conditions only under certain meteorological conditions

Givoni [44] concludes in his experiment to study the effect of ventilation on buildings with different thermal masses that night ventilation out-performed other modes of ventilation by lowering the indoor maximum temperature in high mass buildings in comparison with low mass buildings.

Chyee et al. Toe et al. [45] demonstrate that high thermal mass houses with roof insulation and small internal courtyards would maximise the benefit of night ventilation in the Malaysian tropical climate, while Shaviv et al. [46] studied the influence of thermal mass when using night ventilation on the maximum indoor temperature in different locations in Israel. The results were turned into a design tool to help predict at the early stages of the design process the conditions most favourable for maximum benefit from night ventilation and thermal mass.



Landsman et al. [47] suggested that the most influential parameters that affect the thermal performance of night ventilation is the ventilation system set point; the higher the set point the higher the efficiency, as well as the number of hours of operation of the ventilation system; the longer the hours the more benefits can be achieved. Equally important is the outdoor night time temperature, the lower the temperature, the greater the potential of night ventilation. The results of the study also showed that night ventilation in mild climates can maintain the indoor temperature within 80% of the acceptable comfort limit (indoor comfort range 17 C to 27 C and 50% + or – 10% Relative Humidity).

Chenari et al. [48] highlighted the importance of improving the efficiency of ventilation systems to reduce the impact of local and international guidelines pertaining to the requirements of outdoor air to maintain indoor air quality. They also highlighted the significant importance of hybrid mechanical and natural ventilation systems with control strategies to enable switching between the active and passive systems (that is, mechanical and natural), which will lead to accumulating savings in energy while maintaining indoor air quality.

Omrani et al. [49] highlighted the importance of natural ventilation as a passive cooling strategy to reduce energy demand in regions where cooling is necessary. They proposed a process model that would help in evaluating as well as adopting the design of natural ventilation in multi-story buildings. Various evaluation methods were considered with the aim of developing a more cost-effective inexpensive method of evaluating the potential natural ventilation during the design stages of the building projects with more accurate methods to be used as the design develops further and during construction. TAS (an industry-leading building modelling and simulation tool) simulations were conducted during a number of thermal discomfort hours in a typical year. It was concluded that full day natural ventilation can improve the thermal comfort in the hot-humid climate of Singapore. This, coupled with a number of passive design measures, such as horizontal shading devices, increased window to wall ratios (0.24) and, surprisingly, no insulation in walls, can lead to better results (this requires further investigation). In addition, careful design of facades would help in gaining more benefits from natural ventilation [50].

Santamouris et al. [51], analysed the energy data from 214 air-conditioned residential buildings using night ventilation to help reduce demand for energy. They reported that the potential contribution of night ventilation increased within buildings with higher cooling demands under specific boundary conditions and that an increased air flow rate is another potential contributing factor.

#### 4. Nocturnal radiation exchange (NRE)

Nocturnal Radiation Exchange (NRE), also, known as Nocturnal Sky Radiation Cooling (NSRC), Passive Radiative Cooling (PRC) and Night Sky Cooling (NSC) is the cooling of building by rejecting heat to the night sky which acts as a heat sink. Flat surfaces such as building roofs absorb most of the solar radiation during the day. The surface temperature of sun-exposed surfaces in warm climatic regions can reach well above 70 °C and a record high black bulb temperature of 85°C has been reached. Provided the right meteorological conditions exist, i.e. a clear sky, a low moisture content in the air, the absence of dust or low dust levels, minimal pollution and a reasonable diurnal-nocturnal temperature range, the night sky acts as a heat sink which absorbs longwave radiation from building surfaces, particularly those exposed to the sky, i.e. roofs of buildings, walls not obstructed by nearby buildings, hills, trees, etc. It is an old technique [52] which human beings gradually, through a process of trial and error that spanned centuries, learned how to adopt and make use of in their localities to reduce the impact of the adversity of the climate throughout the seasons. Being a passive strategy, it has gained a lot

of interest by researchers over the last past 40 years and more so recently with the perceived changes in the climate due to pollution and the uncertainty of the energy market. The night sky plays the role of a heat sink exchanging radiation with hot surfaces on earth. This results in heat losses from building surfaces exposed to the night sky. The greater the exposure is, the higher the rate of heat rejection and the lower the surface temperature will drop. This phenomenon, if deployed on its own or in a hybrid HVAC system as a passive strategy, can help cool down buildings at night to near comfort range in some regions. The main challenge with nocturnal cooling is how to store the coolness at night for utilization as long as possible during the day and not just when the conditions are favourable for nocturnal radiation exchange at night.

A hybrid NSRC system, which included a number of active components such as a heat pump and several pumps to move the cooling medium (water) across the various components of the system as shown in Fig. 11, was used in a research study by Amir et al. [53], in which it was concluded that a hybrid system employing more than one strategy (passive and active) will offer the maximum benefits and performance.

Man et al. [54] used nocturnal cooling radiation in a novel nocturnal cooling radiator to aid the heat rejector of a conventional active cooling system, when meteorological conditions permitted, to improve its energy performance. The simulation results in a humid tropical climate proved that it is feasible to use nocturnal cooling to supplement as a heat sink the heat rejection capability of an active cooling system.

Zhao et al. [55] experimented with a conventional PV panel modified to be operated as diurnal PV panel and a Nocturnal Panel. The PV-RC system schematic and the actual modified PV Panel can be seen in Figs. 12a and 12b. The PV panel face was covered by a transparent low-density polyethylene sheet while all other 4 sides and the bottom were well insulated with polystyrene thermal insulation to ensure no heat transfer or gain which might reduce the performance of the panel. The panel was installed on the roof a building and was only protected with the low-density polyethylene cover during the nocturnal cycle.

He concluded that the PV panel thermal emission within the infrared wavelength band makes it a potential candidate for doubling up as nocturnal radiative cooling panel during the night hours. An average of 12.4% PV conversion and an average equilibrium temperature difference ( $\Delta T_{ap}$ ) of 12.7°C for nocturnal RC process were achieved, which supported the idea of PV panel dual function (PV conversion during day time and nocturnal cooling during night time). He also demonstrated that the performance is significantly affected by water moisture in the air, which proved that low humidity regions allow for better performance. Also, a clear night sky is equally important to release the full potential of the nocturnal cooling strategy. With polluted skies due to burning of fossil fuels, nocturnal cooling on its own may not be the most rewarding solution. A hybrid system along with the deployment of other passive strategies would offer the best chance to achieve better results.

et al. Zhang et al. [56] demonstrated the potential of using a hybrid system combining Microencapsulated Phase Change Material (MPCM slurry storage) with nocturnal radiative cooling. Encouraging though limited results were produced showing a potential annual energy saving when this strategy is applied in low rise buildings. The savings ranged from 12% to 77% across five cities in China as can be seen in Fig. 10. Shuo et al recommended the use of this strategy in northern and central China where the metrological conditions are more favourable for nocturnal radiative cooling, being dry with low ambient temperatures at night.

Bokor et al. [57] used a corrugated perforated metal plate as a radiant surface, as can be seen in Fig. 13, to study the potential of nocturnal cooling in four European Cities. He concluded that nocturnal cooling performs better in locations with drier climates due to the

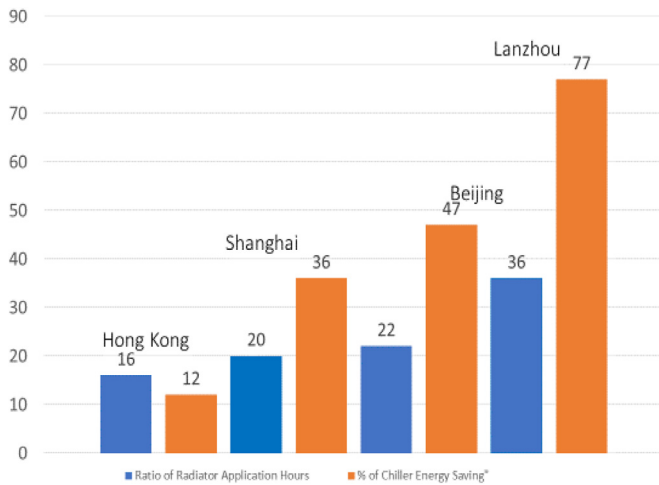

Fig. 10. % of chiller energy saving and the utilization ratio of nocturnal radiator [51].

absence of water moisture in the air, which impedes the radiation exchange with the night sky. In this paper the use of TSC (Transpired Solar Collector) is being suggested as means of doubling the benefit of a solar collector by using it for cooling the air through longwave radiation exchange with the night sky (i.e. Nocturnal Cooling) in the warmer months as well as a solar heater in winter. Encouraging results were produced but further research work needs to be carried out to test this approach and determine its feasibility as a strategy to aid active HVAC systems and in turn reduce their energy footprint. It may be worth investigating applying the same strategy with the use of purpose-built solar air heaters which permit the living space air to circulate through them (for winter heating), a technology evolved out of the Antarctic expeditions to heat tents in the harsh frozen conditions of the south pole. The same device can be used in reverse in summer to cool down the air at night and allow air circulation in the living space.

Nwaji et al. [58] investigated a hybrid flat plate water heating solar collector that can double up as a nocturnal radiator to demonstrate the worth of investigating this passive strategy further. The finite element analysis of the dynamic performance of the solar collector in five Nigerian city temperatures produced impressive results. The difference between the maximum achieved during the diurnal period and that achieved during the nocturnal period was 73.55 °C, i.e. 93.67 °C in the case of diurnal heating and 20.12 °C in the case of nocturnal cooling. Further investigation is required.

Wang et al. [59] developed a new numerical algorithm based on a solution of the energy balance equations in an attempt to characterize the complex thermodynamics of nocturnal cooling when applied to intensively urbanized cities. The complex urban development

landscape surface and surrounding atmosphere with its multitude of interwoven parameters such as tall buildings, short buildings, masonry and glazed facades, flat and sloping roofs, asphalted streets, parks, etc., which lead to what is known as Urban Heat Islands (UHI), are but a few of the challenges met. Further work needs to be carried out to understand nocturnal cooling better and to attempt to quantify its benefits in the context of UHI.

Lu et al. [60] reviewed the potential of different PRC (Passive Radiative Cooling) systems to assess their performance by simulations. It was concluded that the diurnal performance is limited when compared to nocturnal performance even under the most suitable meteorological conditions. It was also concluded that the commercialization of this passive strategy is heavily dependent on the discovery, reliability and availability of the coating materials, which themselves are subject to extensive research and development work.

Hua et al. [61] looked at diurnal solar heating and nocturnal radiative cooling using a Solar Heating/Radiative Cooling Collector as illustrated in Fig. 14. A mathematical model to establish the performance of the collector in both modes was established. The thermal performance of the collector was investigated using parameters with different specifications and conditions, e.g. insulation thicknesses, wind velocities, ambient and inlet temperatures, water flow rates, precipitable water vapor amounts and solar irradiance. It was concluded that the multi functionality of the solar collector through its increased utilization was one of the main advantages when compared to traditional single mode solar thermal collectors. The heating and cooling gains varied across the four Chinese cities in which the collector was investigated. Parameters such thermal insulation, ambient temperature and wind speed impacted directly on the performance of the collector in both modes. Further research work is required to establish the practicality and cost effectiveness of such multifunction collectors under various meteorological conditions.

## 5. PCM and IEC

The application of thermal energy storage (TES) in a building significantly reduces energy consumption. It allows an improvement in the efficiency of systems by postponing the use of accumulated energy for use during the period of the highest demand [62]. One of the TES approaches are phase change materials (PCMs). These materials can be used in the construction of walls [63,64], ceilings [65], roofs [66], floors [67], as well as PCM-to-air heat exchangers for building envelope applications [68]. The incorporation of PCM allows a reduction in the temperature variation in the room, thus significantly improving the thermal comfort of users and increasing the building's thermal inertia [69]. As a result of phase change, depending on the properties of the PCM, a large amount

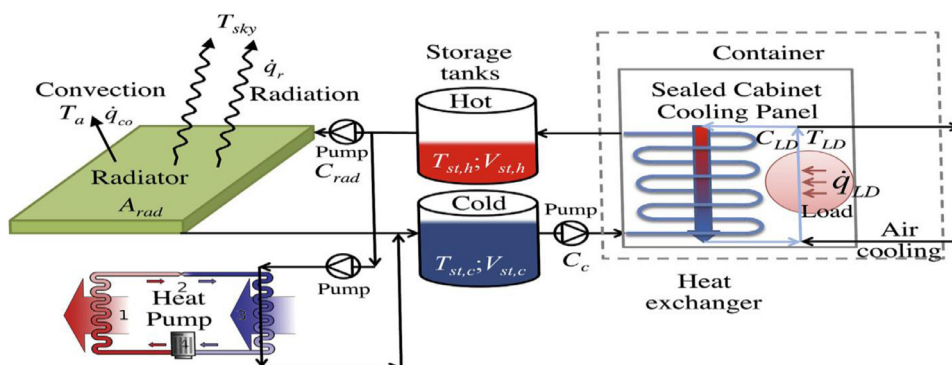

Fig. 11. Schematic layout of the hybrid nocturnal sky radiation cooling system [48].

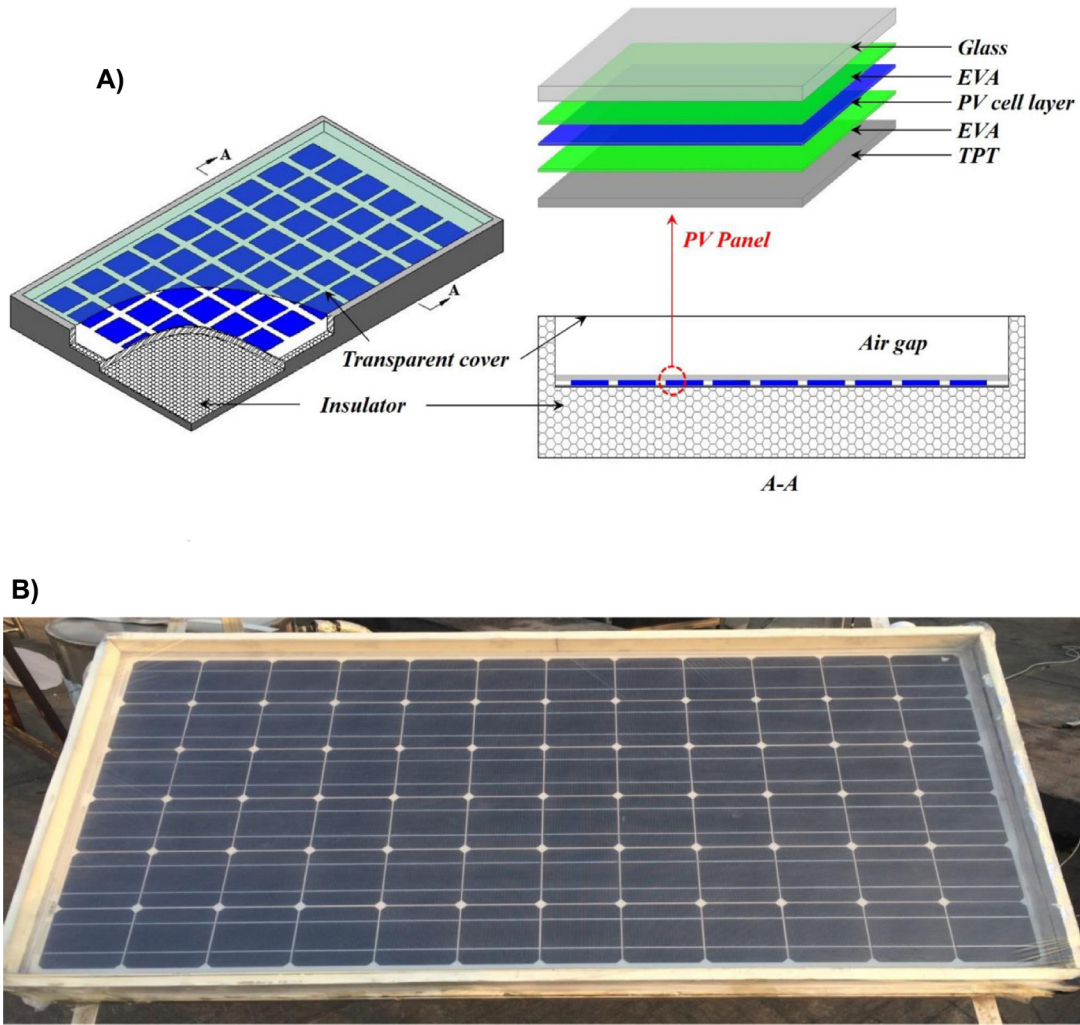

Fig. 12. A) Configuration of the PV-RC hybrid system – Schematic. B) Configuration of the PV-RC hybrid system. Actual panel [55].

of heat or cold can be stored as latent heat. Depending on whether additional air handling equipment is needed or not, passive or active cooling can be specified [70].

The PCM can be applied with natural ventilation as a free cooling system (FCS) to store the cold from the outside air during the night and release it during the day when the room temperature rises. At

night the PCM is charged (solidification of PCM - when the outside air with a lower temperature than the inside air flows through the PCM storage) and during the day the PCM is discharged (melting of the PCM as a consequence of absorbing heat from the internal air and simultaneously lowering its temperature). The concept of free cooling is presented in Fig. 15.

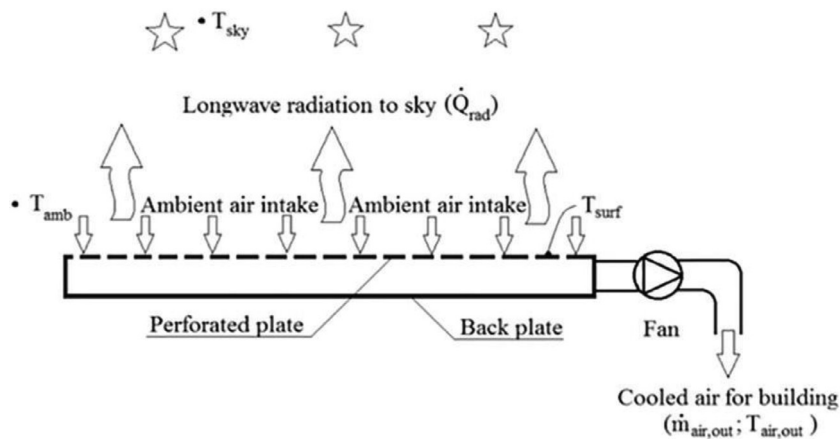

Fig. 13. Scheme of the Transpired Solar Collector setup for nocturnal radiation air cooling [52].



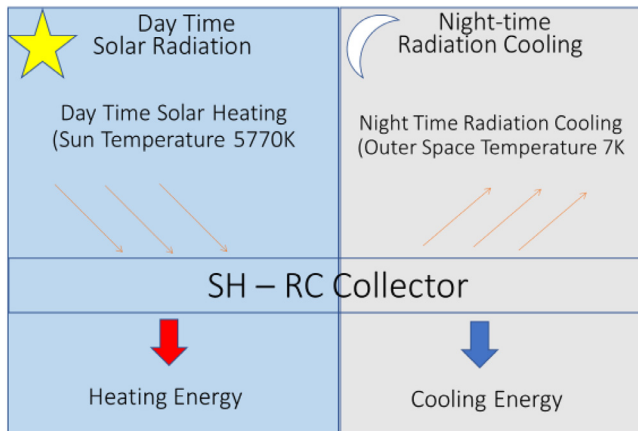

Fig. 14. Graphic representation of Diurnal Heating and Nocturnal Cooling [61].

The three main parameters affecting the performance of PCM-based free cooling are [70]:

- local climatic condition,
- thermophysical properties of the PCM and its phase change temperature range
- inlet velocity and temperature of the heat transfer fluid as well as its thermo-physical properties.

In a review article, Thambidurai et al. [71] have prepared a list of PCMs which could be used in free cooling, taking into account melting point, heat of fusion and density. The authors have compiled in tables eutectic, inorganic and organic PCMs and commercial PCMs applicable in free cooling. One of the main conclusions of the article was that free cooling works best in climate zones with low humidity and a large daily temperature range. In humid and warm climatic conditions additional air dehumidification is required, however, the authors do not indicate what additional design conditions for heat exchangers should be met. P. Rathore et al. [64] presented methods of applying macro-encapsulated PCM in building envelopes and in systems including free cooling. In one of the cases analysed, it was found that, in hot and dry climatic conditions, a lower flow rate through the air gaps under consideration within the PCM is required in order to maintain long-term thermal comfort, although a higher flow rate accelerates the PCM charging process. It was observed that the size of the air gap does not affect the thermal comfort. However, the range of thermal comfort parameters was not specified.

Nada et al. [72], analysed the impact of outside temperatures and air flow rate on system performance and charging and discharging

processes of SP-24E PCM with the melting temperature of 25 °C applied in a free cooling system in a laboratory experiment. The conclusions show that energy savings in the examined air conditioning system depend not only on the outside air temperature and fresh air flow rate but also on the amount of PCM plates needed. The same authors in [73] investigated the fresh air free cooling system for which the difference between the PCM (type SP24E) melting temperature and the air temperature is 2–4 °C (for three different air flow rates). They indicated that PCM solidification cannot be ensured overnight without additional requirements. At the same time, the results have proved that PCMs including SP24E are mixtures of compounds. Both articles have shown that in the airflow direction the temperature of PCMs plates goes down and the air flow rate needed at night decreases as the outside temperature drops.

Panchabikesan et al. [70] proposed increasing the thermal performance of a free cooling system based on PCM by combining it with direct evaporative cooling (DEC) unit, Fig. 16. They conducted an experiment under Indian climatic conditions in real time in relation to PCM solidification, charging time, total and temporary heat transfer including different heat transfer fluid (HTF) inlet air velocities. It has been concluded that in the proposed system, the increase in HTF velocity has a negligible impact as opposed to a typical free cooling system. In addition, a significant reduction in charging time (28.7% and 34.8%) was observed regardless of the HTF velocities applied (2 and 1.5 m/s). In the continuation of the work, the authors propose to focus on the parametric analysis of the system, however, they omit the issue of other climate conditions.

In article [74], the authors compared the FCS with the system coupled with the DEC unit under tropical Indian climate conditions throughout the year. They have estimated the monthly average cooling potential of the systems analysed and compared the results with those of the pilot-scale experiments in three cities with temperate, hot-dry and warm-humid climates. It was found that, regardless of local ambient conditions in hot and warm humid climates, the application of FCS with DEC reduces the duration of the complete PCM solidification process and doubles the possibility of using free cooling from May to August in a building. Furthermore, the authors do not recommend using PCM with a phase change temperature below 27 °C in tropical climates. Fig. 17 presents the principle of FCS and FCS with DEC during the PCM charging process. It is worth noting that the authors state that in warm and humid climates there are small temperature fluctuations during the day, and then the temperature difference between the night-time outside air and the PCM is lower than 3 °C and the system will not work properly.

Evaporative cooling requires much less electricity compared to a mechanical compression system [75] and has a very small impact on global warming [76]. The second method of evaporative cooling is

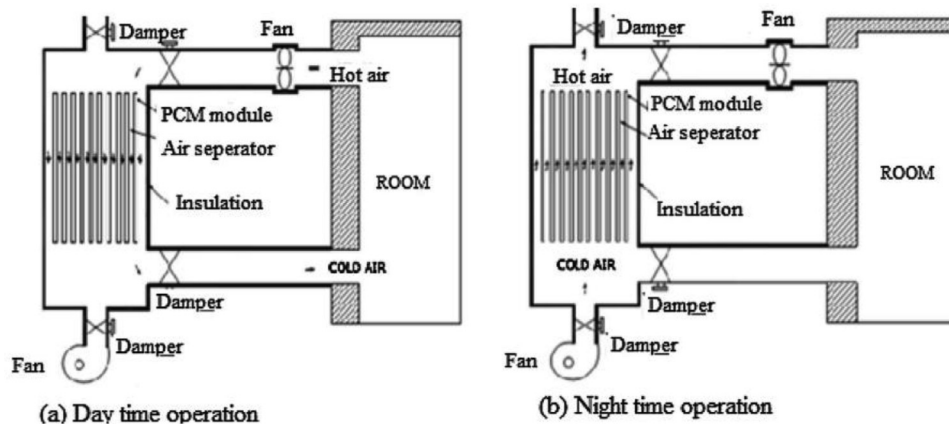

Fig. 15. The concept of free cooling [71].



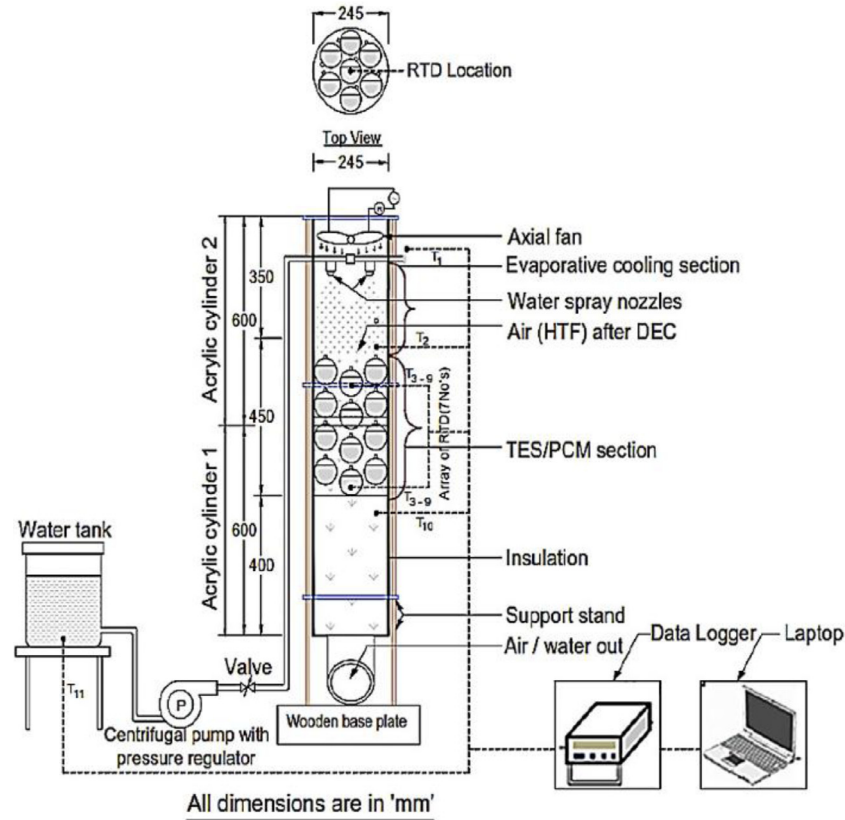

Fig. 16. Modified free cooling system integrated with DEC unit (reproduced from [70]).

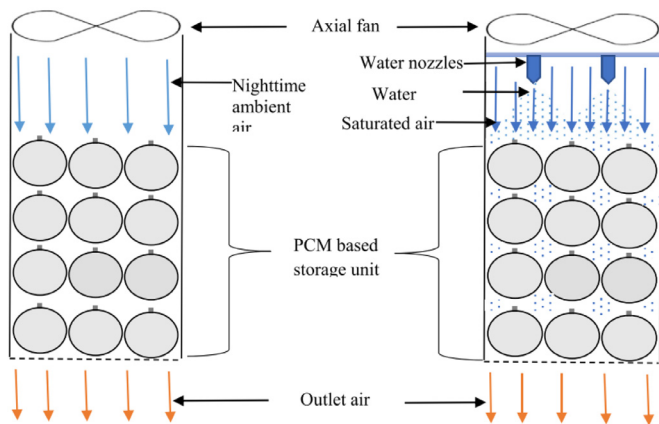

Fig. 17. PCM solidification - FCS (left) and FCS with DEC (right) operating principle [74].

indirect evaporative cooling (IEC). In the case of direct cooling, the warm dry air was transformed into moist and cool air. The IEC consists of transferring heat and mass between two airflows, which are separated by a heat transfer surface. This process is based on heat absorption by evaporation of water to decrease the air temperature with no moisture added. Furthermore, it prevents contaminated water droplets from entering rooms, increasing health safety [77]. The difference between the two methods of cooling is shown in Fig. 18. Such an evaporative cooler consists of fans, heat and mass exchanger, a water distributor/a water basin and a water pump.

In many publications, the authors focused on the analysis of the IEC system and on improving its performance. Xu et al. [77] analysed 6 samples of cloth fabrics and one sample of Kraft paper to examine

their ability to wet areas, wick moisture, evaporation rates and diffusion rates.

Huang et al. [75] analysed experimentally two types of heat exchanger (horizontal and vertical as shown in Fig. 19). Analyses have been carried out in five regions of China and it was found that in humid regions the use of a horizontal exchanger is not recommended due to an uneven distribution of the water layer in the exhaust air ducts. The specific energy saving parameter ( $\delta$ ) defined in the article does not take into account the air supply parameters (air supply temperature, which may be too high) and assesses only the energy savings of the equipment. Thus, when IEC is used in the hot and wet area, it may necessitate additional processes for the supplied air.

Zheng B. et al. [78] analysed a model for a cross-flow IEC unit (Fig. 20) for a warm and humid climate to determine its performance. It was found that at a relative humidity of fresh air below 50% (especially at 30%-40%) condensation will not occur. Full condensation will appear when the relative humidity reaches over 80%. The total amount of heat transferred continues to increase due to the increase in the amount of latent heat transferred even though the amount of sensible heat is decreasing. It is possible to reduce primary air humidity in hot and humid climates by up to 36%. In their calculations, the authors do not specify to what range the values are different for each parameter under examination.

Chen Q. et al. [79] considered the fact that, in hot climates, not only cooling but also fresh water is needed, and they proposed integrating the humidification-dehumidification desalination cycle (HDH) with indirect evaporative cooling according to Fig. 21. The results of the analysis showed that, under the same operating conditions, the connection to IDC increases the gain-output ratio (GOR) for HDH compared to standalone HDH operation. Because of the marginal power consumption in the IEC cycle, the total COP of the coupled IEC-HDH cycle is close to the GOR of the HDH system. These

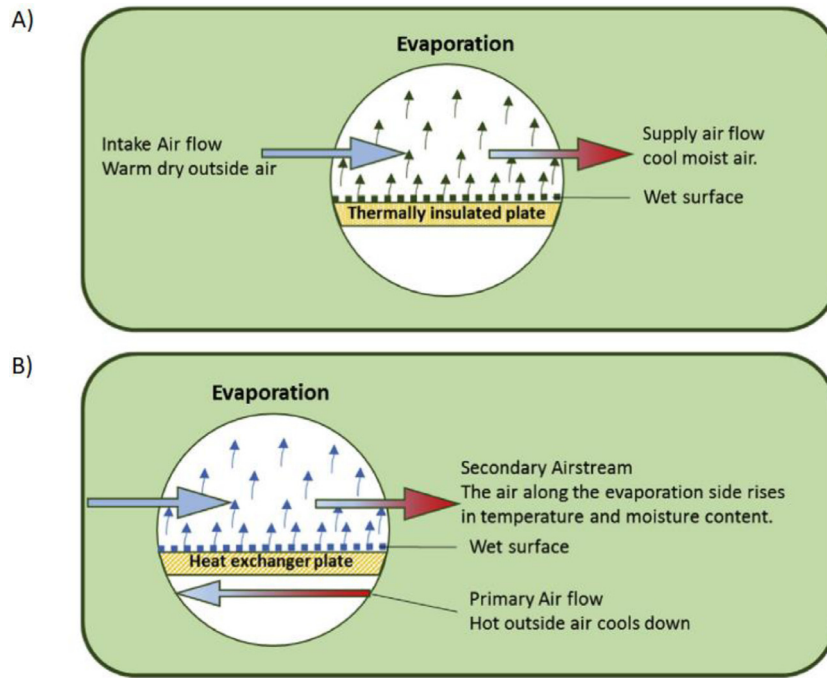

Fig. 18. Evaporative cooling: A) direct, B) indirect [77].

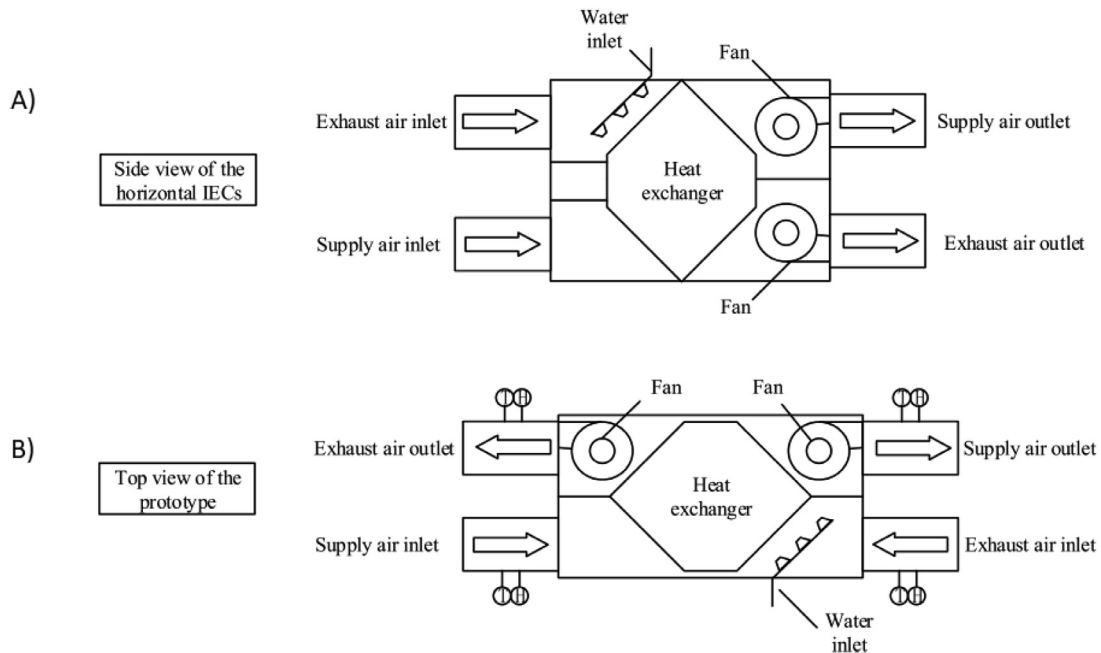

Fig. 19. Schematic of: A) side view of vertical IEC B) top view of horizontal IEC [75].

results are based on the assumption that the outside air has low humidity in IDC. Otherwise, it is necessary to use a dehumidifier to maintain the efficiency of the IEC device.

Rampazzo M. et al. [76] proposed coupling FC with an IDC system, Fig. 22. In order to analyse the work of the main element (evaporative heat exchanger) they built a First-Principle Data-Driven model in Matlab software. The simulations indicate a correct imitation of some basic thermal aspects of the IEC process.

Al Horr et al. [80] proposed methods leading to energy savings, which can be implemented in the logic of automatic control of indirect evaporative cooling systems. The authors in their work answer

the question which operating mode, water spraying, mist injection or a combination of them or dry mode will be best suited for the selected assessment environment conditions. Their analysis concerned an indirect/direct evaporative cooling unit in Qatar as presented in Fig. 23 but only for three air parameters: 26°C/55%RH, 38°C/55%RH, and 42°C/25%RH. In their studies, they have shown that, depending on the operating mode, the variation in cooling performance can differ by up to 41% and when IEC operates in hot climates, it can enable a decrease in the cooling load. Wet modes have been found to save up to 43% of the cooling demand compared to dry modes.

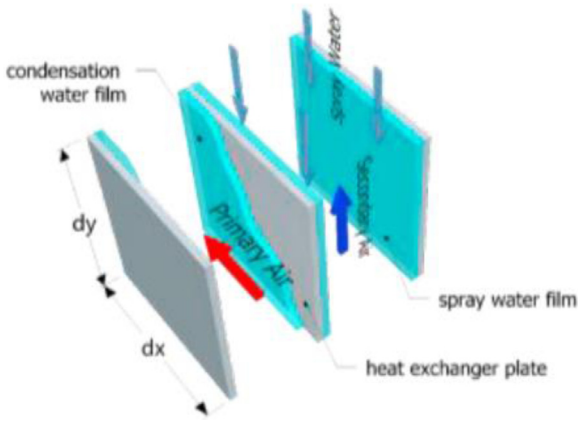

Fig. 20. Cross-flow IEC with condensation – model [78].

**6. Solar thermal energy**

Solar-energy can be harnessed as a green source of energy to provide electricity and heat and can improve the energy efficiency of buildings. This is primarily done by using conventional photovoltaic and thermal collectors or a combination of the two technologies, namely, as PV/T, on the envelope or roof of a building [81]. Extensive research has been conducted into improving the utilisation efficiency of harvesting solar energy and it indicates that the highest possible production of heat and electricity can be obtained using the PV/T technology. This is found to be mainly due to the fact that the heat absorbed from the photovoltaics cells by the thermal panel can actually increase the electricity generation, improving the overall energy output from the system and, as a result, delivering more energy to the building [82]. It is found that, generally, the efficiency of photovoltaics panels can drop by approximately  $0.5\%/^{\circ}\text{C}$  increase in the cell temperature, which in results in a reduction of the electrical generation efficiency of the panel, which is, in any case, only in the range of 10-20% [82]. This has therefore led to much innovative research to discover new methods of developing state-of-the-art photovoltaic-thermal technologies for use in buildings.

For instance, and as can be seen from Fig. 24, Yu et al. [83] discovered that, by placing solar panels on the Trombe wall envelope of a

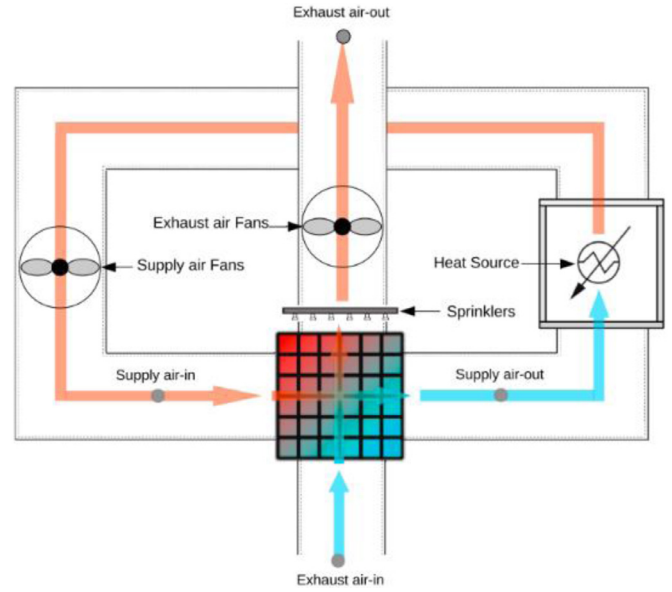

Fig. 22. IEC-FC system layout with the counter-flow configuration [76].

building, electricity can effectively be generated with the highest conversion efficiency throughout different seasons of the year. The configuration can also be used to provide space heating with efficiencies of almost 12% and 37% in winter and summer subsequently, while degrading gaseous formaldehyde by circulating the air through the system. The PV cells are cooled using diverted flowing air or water, depending on the energy demand and output requirement of the building.

Similar configurations of cooling techniques can also be used separately from the building envelope to absorb the thermal energy from the PV panels and deliver it to the internal environment. The above-mentioned techniques can include a fan, for instance, to improve the electrical efficiency from the PV panels, while increasing the thermal energy output from the system. As an example, Elminshawy et al. [84] connected a fan to a buried heat exchanger (BHE) to force ambient air underneath a photovoltaic panel. This configuration, as can be seen from Fig. 25, allowed the generation of pre-cooled

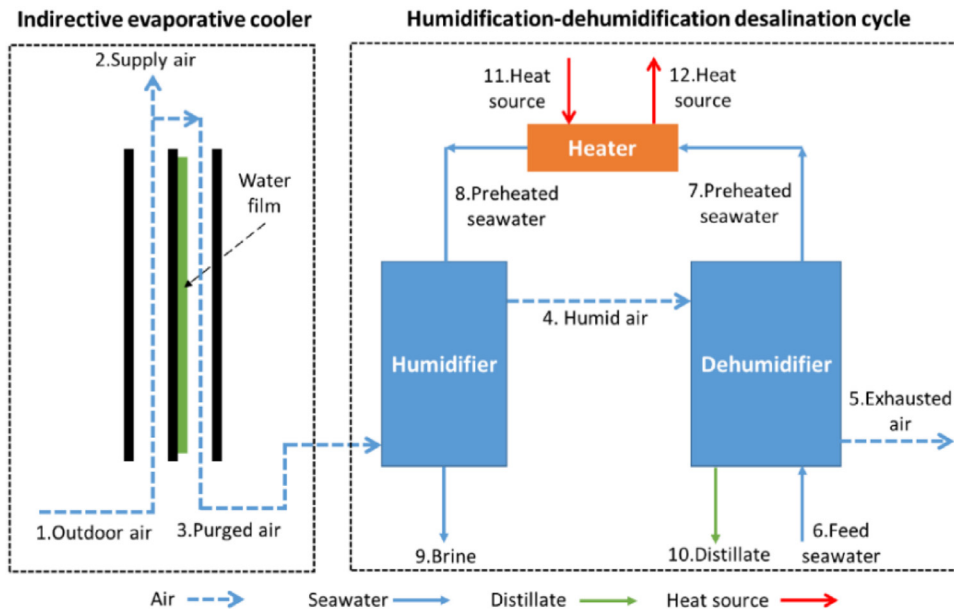

Fig. 21. Coupled IEC-HDH cycle- schematic [79].

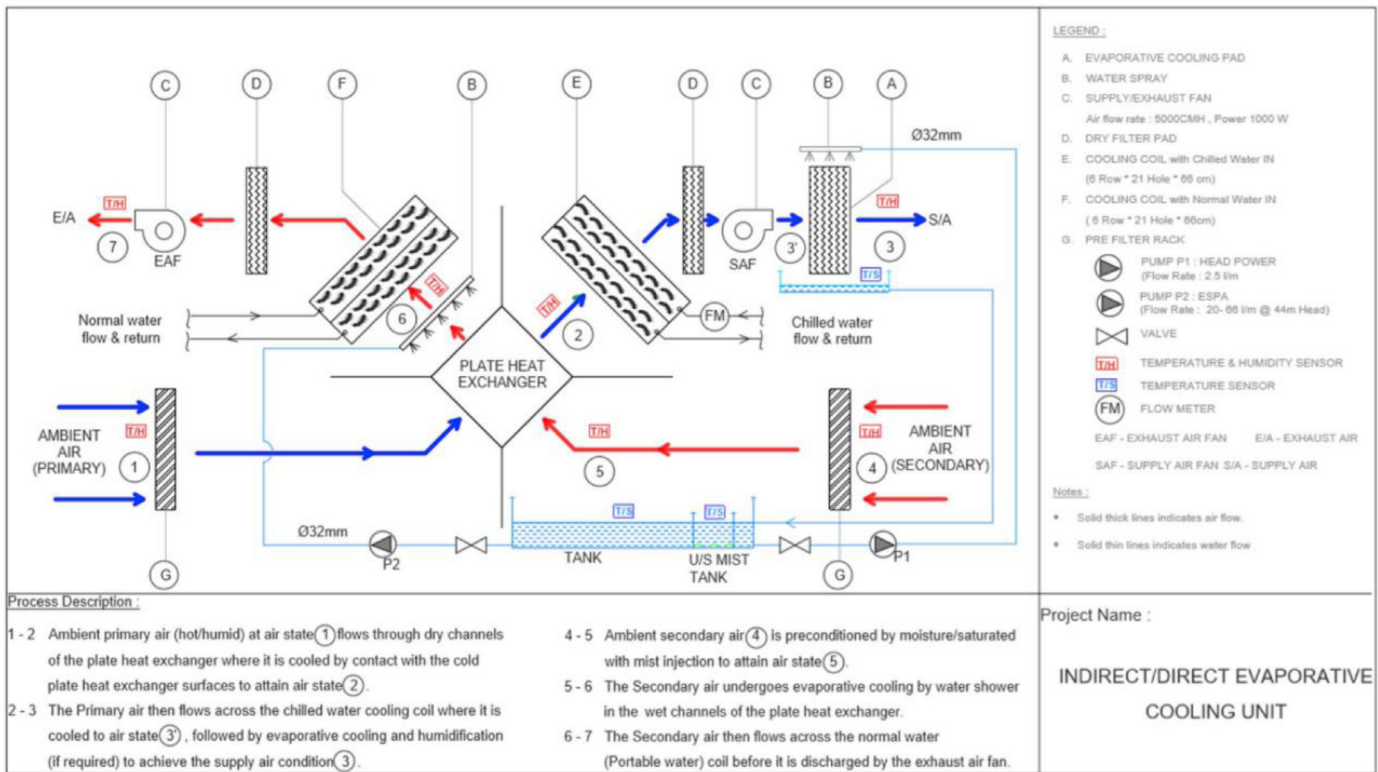

Fig. 23. Indirect/direct evaporative cooling unit [80].

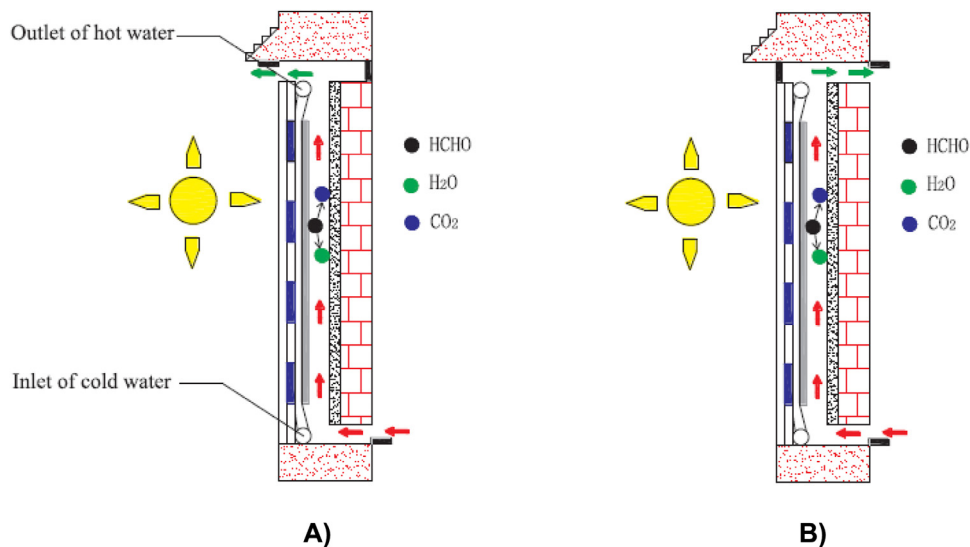

Fig. 24. Different arrangements of PV/T with Trombe wall for A) summer and B) winter [83].

air from the ground heat exchanger, which, in return, was supplied to the back of the PV cells to provide a temperature drop for the panel. The experiment was conducted at various ambient temperatures and the results indicated that the cooling technique can lead approximately to a maximum electrical efficiency improvement of up to 30%. The thermal efficiency delivered from the system was discovered to have increased to nearly 45%. It is important to note that the BHE's thermal performance depends on the type of soil and its moisture.

The method of thermal management employed for photovoltaic panels also depends on the location at which they are being used. For example, as Kabeel et al. [85] found, in a hot climate water cooling of PV yield the highest efficiency gain. However, in their research they

do not give the temperature of the PVT panel cooling water but only the 12l/min flow rate. Nizetic et al. [86] used a manifold to spray water over the top and bottom surfaces of a PV panel and discovered that a maximum improvement in the power output efficiency of about 16% can be achieved using this method at peak solar irradiation. The test indicated that the temperature of the solar panel can be brought down to nearly 30°C from almost 54°C.

The above studies do not take into account the fact that in hot climates water is very often lacking. The process of cooling water operation, especially in a closed system, will generate additional costs.

Other techniques, such as the use of Phase Change Materials or PCMs for cooling, have also shown promising results in terms of



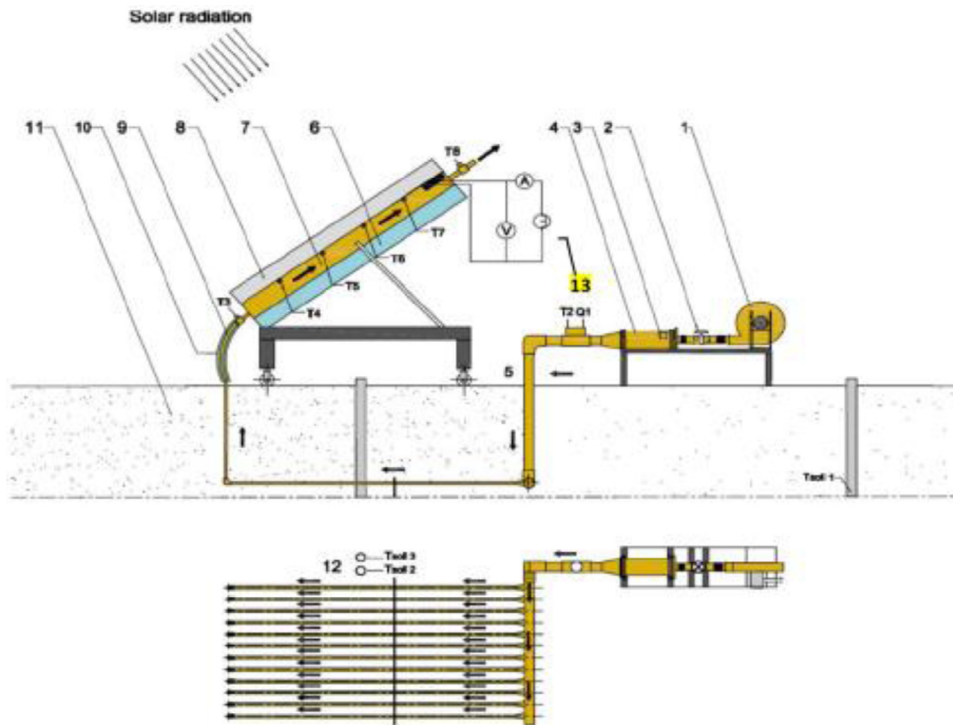

Fig. 25. PV panel with buried heat exchanger cooling arrangement [84].

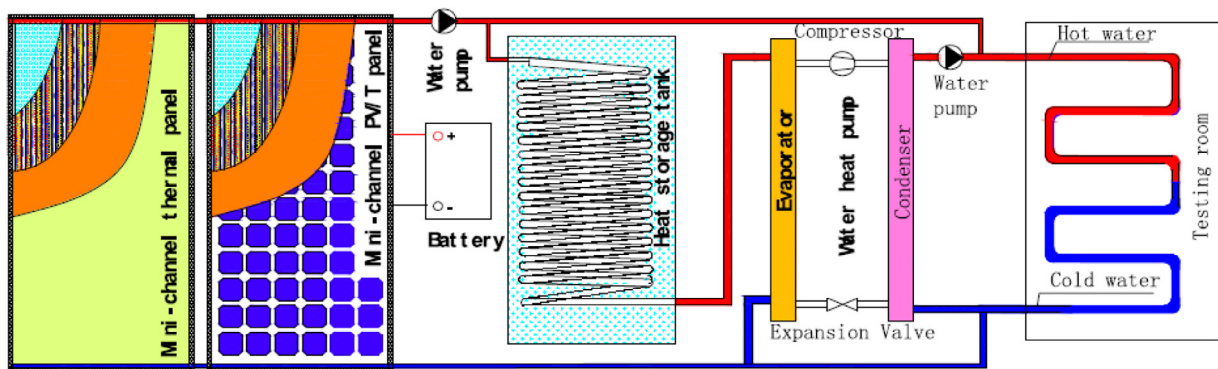

Fig. 26. Schematic arrangement of PV/T coupled with Heat pump [88].

efficiency improvement where there is stable solar radiation. For instance, Hasan et al. [87] conducted an investigation into using different PCM materials, namely, salt hydrates and eutectic mixtures, for cooling PV cells in a cold and hot climate. The research led to the discovery that both PCMs can help to manage the temperature of the panel better in a hot climate. The salt-hydrate PCM achieved about a 4% higher temperature drop and improved the power output by almost 3%. However, in warm climates there is a problem with the removal of stored heat in PCMs. Because of the high temperature at night, the PCM does not solidify completely and, as the authors note, "coolant flow into the PCM to maximise heat extraction may be required".

Thanks to the useful production of both electrical and thermal energy by PV/T panels, these systems can also be combined with other technologies such as heat pumps to generate and deliver energy in a more sustainable and efficient manner in areas with lower solar irradiation. For instance, Zhou et al. [88] coupled a heat pump with a PV/T system and discovered that space heating for buildings can be effectively generated in regions with low solar irradiation. For this system and, as can be seen from the Fig. 26, the panel

is connected in a parallel configuration to a heat pump that is used as an auxiliary heating unit. The heat pump employs a compressor, an evaporator and a condenser to utilise and increase the temperature of the water in a storage tank that is connected to the thermal panel. The heat stored in the storage tank can then be used as useful thermal energy in a building envelope.

In an experiment and using the developed system, it was found that the electrical, thermal and overall efficiencies of the heat pump incorporated PV/T system can reach almost 16%, 33% and nearly 50%, respectively, while keeping the room temperature at above the comfort level of 18°C. The COP of the heat pump was indicated to be 4.7 with the system fully functioning.

The heat pump combined system can also be used for efficiency output management of the photovoltaic cells. For instance, Lazzarin and Noro [89] managed to employ a glazed PV/T system in combination with a ground source heat pump and discovered that, with this configuration, the thermal and electrical output efficiencies from the panel can be kept at an optimal level. The experimental set up included a refurbished building that comprised a dual source heat pump and used the ground as a heat sink and source, depending on

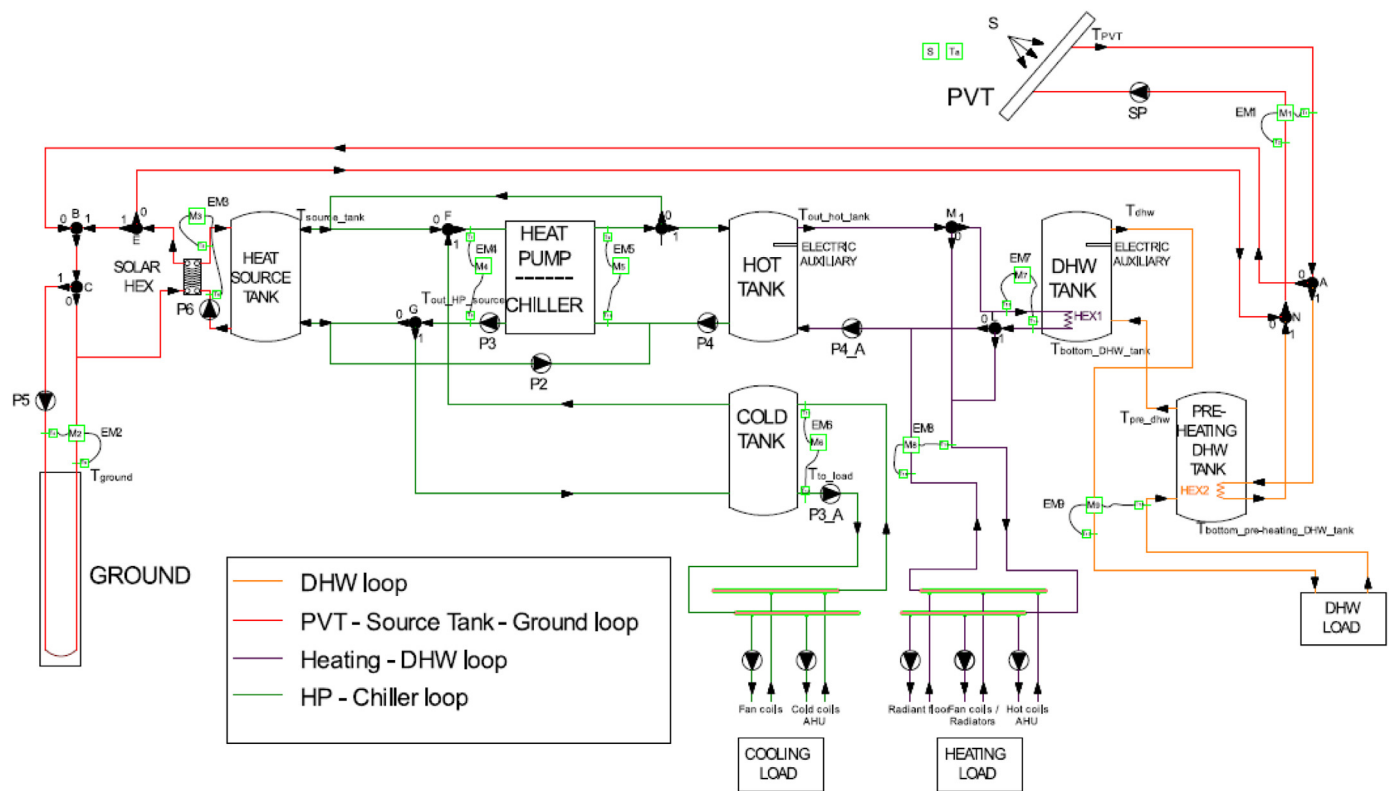

Fig. 27. Piping and instrumentation diagram of dual PV/T integrated heat pump system [89].

the season of the year, to thermally manage the temperature of the photovoltaic cells. The results from the experiment suggested excellent system performance, while the energy output was obtained with highest indicated efficiencies. Fig. 27 shows the piping and instrumentation diagram (P&ID) for the configuration of the system.

Having reviewed the above investigations, it is noted that the use of heat pipe-based cooling techniques have also shown promising results in terms of both effective thermal energy delivery and efficiency improvement for PV panels. Yu et al. [90], for example, as can be seen from Fig. 28, used a micro-channel loop heat pipe as heat absorber and a tubular heat exchanger with water as heat sink to decrease the surface temperature of a PV panel. In this experiment, the heat pipes were filled with the refrigerant R134a as the working fluid and were placed under the solar panel to absorb and deliver heat to a cooling manifold where the heat exchanger was located. The working fluid in the heat pipes offers a rather low boiling point. Since the heat pipes are placed under the surface of the PV panel, a slight increase in temperature evaporates the working fluid within the heat pipe, which travels passively to the cooler section of the system where the water manifold is located. The working fluid then delivers its latent heat to the heat exchanger, condenses and returns to evaporate at the surface of the panel. This delivers the heat absorbed by the PV cells effectively and efficiently to the water flow [91]. The water flow can then be diverted to a thermal storage tank where it can be used as hot water for a household [92]. The results from the experiment showed that a peak solar thermal efficiency of almost 70% can be achieved through the use of micro-channel heat pipes, while the electrical efficiency maximised to nearly 18%.

Jouhara et al. [93,94] took advantage of the benefits offered by heat pipes in an experiment and manufactured a building integrated PV/T solar roof, which improved both the electrical and thermal performances of the solar panel when compared to other state-of-the-art technologies [82]. In this experiment and as can be seen from Fig. 29, PV panels were attached to the surface of a flat heat pipe, namely as a heat mat, and cooled through water which passed

through a cooling manifold, transferring the absorbed heat from the cells.

As shown in the Fig. 30, the manufactured heat mat panels were then placed on the roof of a demonstration building representing a small dwelling and the results obtained demonstrated that the overall system conversion efficiency is increased to around 50% while the PV electrical output efficiency is improved by about 15%.

## 7. Conclusion

In this research paper the following passive energy strategies were reviewed in the context of their application in residential buildings, a power-hungry sector, where a significant portion of the energy is spent on controlling the indoor temperature and humidity for the comfort of occupants:

- NV (Night Ventilation): the use of night-time ambient air when its temperature drops below a certain threshold, by inducing it into buildings.
- NRE (Nocturnal Radiation Exchange): night sky radiation exchange with building surfaces as well as cooling media such as water
- PCM (Phase Change Material) and IEC (Indirect Evaporative Cooling): use of phase change material to increase the sensible cooling efficiency of evaporative coolers and the use of water as a cooling medium whereby air is induced into the evaporative cooler through a controlled spray of water to lower its DBT (Dry Bulb Temperature) when ambient air conditions permit.
- Solar Thermal Energy.
- Passive Building Design.

The review has revealed that extensive research work has been carried out in attempts to quantify achievable energy savings that will help in reducing dependence on gas and electricity in tropical and subtropical regions where indoor climate control, particularly

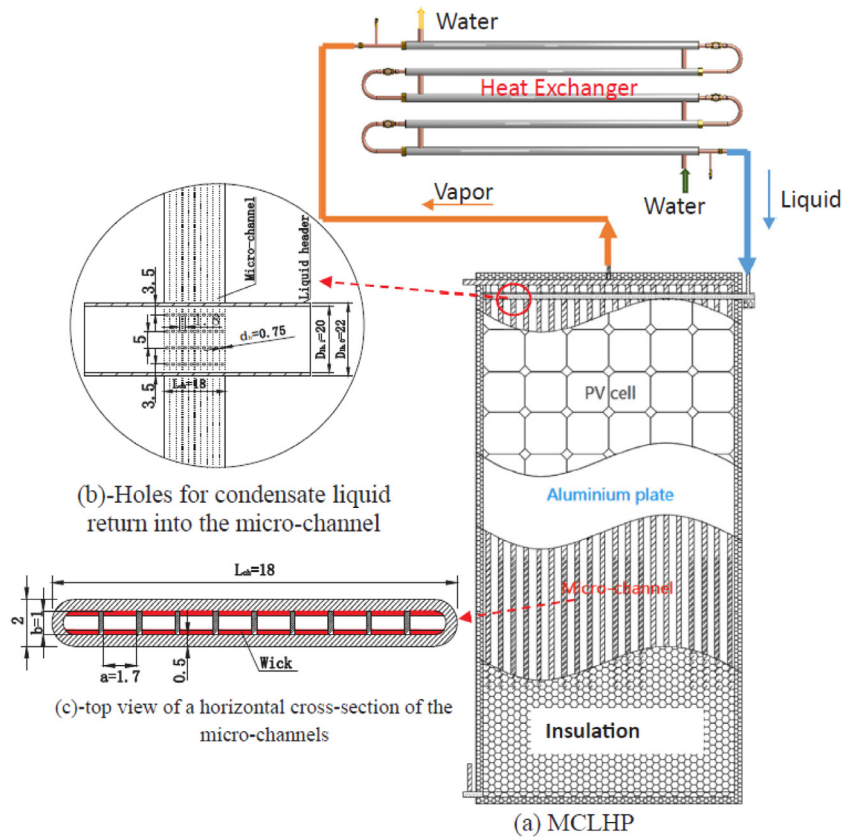

Fig. 28. Design layout of the micro-channel loop heat pipe PV/T system [90].

during the warm seasons, is an expensive necessity. Also, the means of improving the performance of these strategies in a cost-effective way, when deployed either individually or in a hybrid configuration of more than one strategy, have been identified for existing houses as well as houses under design.

It is revealed that there is a need for a real case study coupled with extensive field data gathering over at least 12 months to cover all seasons of a contemporary passively designed houses in locations where meteorological conditions would permit the utilization of free ambient energy to help generate comfort (or near comfort) conditions, thus further improving the thermal performance of residential houses. Also, it is quite evident from the literature review that there is limited research work on an integrated approach of studying the deployment of the selected strategies in this review paper with the objective of maximizing the benefit of free ambient energy

throughout the year. In addition, there is an essential need for the use of an energy efficient HHVAC (Hybrid Heating, Ventilation and Air Conditioning) system, flexible enough to permit integration of the passive strategies discussed in this review paper, as well as being able to optimise the operation of these strategies either individually or collectively for an extended validation period. The HHVAC system design should take into consideration the predominant characteristics of the meteorological conditions for the region being studied. Also, how practical and cost effective it is to implement such strategies in existing houses should be considered and how the findings can enhance current design guidelines for new. Not only comfort conditions should be the objective but as much as possible near comfort conditions, as well as full or partial relief to occupants during peak days in summer and cold winter nights. This will help in understanding better the complexities of how passively designed houses

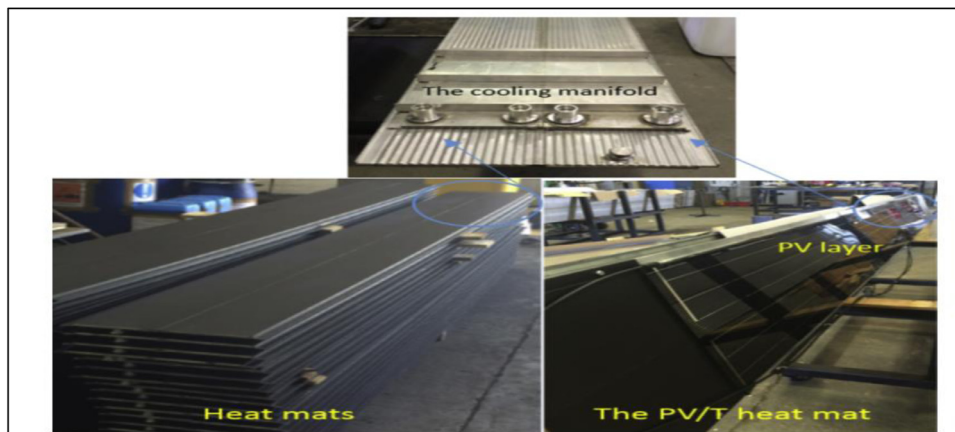

Fig. 29. Heat mat heat pipe technology [93].





Fig. 30. Heat Pipe Based PV/T System [94].

thermal behaviour will improve by the implementation of the reviewed strategies.

#### Declaration of Competing Interest

None.

#### Acknowledgement

This work was funded by the Innovation and Networks Executive Agency (INEA), European Commission for project PVadapt under Grant Agreement number 818342.

#### References

- [1] D Gately, NA Al-Yousef, HMH Al-Sheikh, The rapid growth of domestic oil consumption in Saudi Arabia and the opportunity cost of oil exports foregone, *Energy Policy* (2012) <https://doi.org/10.1016/j.enpol.2012.04.011>.
- [2] A Al-Saggaf, M Taha, T Hegazy, H Ahmed, Towards sustainable building design: the impact of architectural design features on cooling energy consumption and cost in Saudi Arabia, *Procedia Manuf.* (2020) <https://doi.org/10.1016/j.promfg.2020.02.215>.
- [3] CEIC, Saudi Arabia oil consumption, Saudi Arab Oil Consum. (2018) <https://www.ceicdata.com/en/indicator/saudi-arabia/oil-consumption%0Ahttp://www.country-studies.com/saudi-arabia/oil-industry.html%0Ahttps://www.ceicdata.com/en/indicator/saudi-arabia/oil-consumption%0Ahttp://www.country-studies.com/saudi-arabia/oil-indus>.
- [4] M Krarti, M Aldubyan, E Williams, Residential building stock model for evaluating energy retrofit programs in Saudi Arabia, *Energy* (2020) <https://doi.org/10.1016/j.energy.2020.116980>.
- [5] B Jaffar, T Oreszczyn, R Raslan, A Summerfield, Understanding energy demand in Kuwaiti villas: findings from a quantitative household survey, *Energy Build.* (2018) <https://doi.org/10.1016/j.enbuild.2018.01.055>.
- [6] ASU World Meteorological Organization. Global Weather & Climate Extremes Maps n.d. <https://wmo.asu.edu/maps/wmoViewer.html>.
- [7] I. Partridge, Cost comparisons for wind and thermal power generation, *Energy Policy* (2018) <https://doi.org/10.1016/j.enpol.2017.10.006>.
- [8] Bazeeth Ahamed KM. Initial and operational cost of different air conditioning systems in GCC: A supporting case for VRF Systems n.d.
- [9] Sarraf G, Fayad W, El Sayed T, Monette S-P. Unlocking the potential of district cooling the need for GCC governments to take action. Abu Dhabi: 2012.
- [10] Campbell Alison, Hanania Jordan, Jenden James, DJ Stenhouse Kailyn, Barrels of oil equivalent, *Energy Educ.* 1 (2018) [https://energyeducation.ca/encyclopedia/Barrels\\_of\\_oil\\_equivalent#cite\\_note-EIA-3](https://energyeducation.ca/encyclopedia/Barrels_of_oil_equivalent#cite_note-EIA-3).
- [11] NA Azzolina, WD Peck, JA Hamling, CD Gorecki, SC Ayash, TE Doll, et al., How green is my oil? A detailed look at greenhouse gas accounting for CO<sub>2</sub>-enhanced oil recovery (CO<sub>2</sub>-EOR) sites, *Int. J. Greenh. Gas Control* (2016) <https://doi.org/10.1016/j.ijggc.2016.06.008>.
- [12] H Ritchie, M. Roser, CO<sub>2</sub> and greenhouse gas emissions, *Our World In Data* (2017) Retrieved from: <https://ourworldindata.org/co2-and-other-greenhouse-gas-emissions>. [Online Resource].
- [13] S Soimakallio, L. Saikku, CO<sub>2</sub> emissions attributed to annual average electricity consumption in OECD (the organisation for economic co-operation and development) countries, *Energy* (2012) <https://doi.org/10.1016/j.energy.2011.12.048>.
- [14] X Chen, H Yang, W Zhang, A comprehensive sensitivity study of major passive design parameters for the public rental housing development in Hong Kong, *Energy* (2015) <https://doi.org/10.1016/j.energy.2015.10.061>.
- [15] Y Song, J Li, J Wang, S Hao, N Zhu, Z Lin, Multi-criteria approach to passive space design in buildings: Impact of courtyard spaces on public buildings in cold climates, *Build. Environ.* (2015) <https://doi.org/10.1016/j.buildenv.2015.02.025>.
- [16] X Gong, Y Akashi, D Sumiyoshi, Optimization of passive design measures for residential buildings in different Chinese areas, *Build. Environ.* (2012) <https://doi.org/10.1016/j.buildenv.2012.06.014>.
- [17] Ministry of electricity & water Kuwait, MEW R6 Energy Conservation Code, Ministry of Electricity & Water, Kuwait, 2016.
- [18] H Ali, M. Alsabbagh, Residential electricity consumption in the state of Kuwait, *Environ. Pollut. Clim. Chang.* (2018) <https://doi.org/10.4172/2573-458x.1000153>.
- [19] HA. Abdulkareem, Thermal comfort through the microclimates of the courtyard. A critical review of the middle-eastern courtyard house as a climatic response, *Proc. - Soc. Behav. Sci.* (2016) <https://doi.org/10.1016/j.sbspro.2015.12.054>.
- [20] DG Leo Samuel, K Dharmasastha, SM Shiva Nagendra, MP Maiya, Thermal comfort in traditional buildings composed of local and modern construction materials, *Int. J. Sustain. Built. Environ.* (2017) <https://doi.org/10.1016/j.ijse.2017.08.001>.
- [21] AA Bagasi, JK. Calautit, Experimental field study of the integration of passive and evaporative cooling techniques with Mashrabiya in hot climates, *Energy Build.* (2020) <https://doi.org/10.1016/j.enbuild.2020.110325>.
- [22] A Zaki, P Richards, R Sharma, Analysis of airflow inside a two-sided wind catcher building, *J. Wind Eng. Ind. Aerodyn.* (2019) <https://doi.org/10.1016/j.jweia.2019.04.007>.
- [23] Z Zamani, S Heidari, P Hanachi, Reviewing the thermal and microclimatic function of courtyards, *Renew. Sustain. Energy Rev.* (2018) <https://doi.org/10.1016/j.rser.2018.05.055>.
- [24] MA Zakaria, T Kubota, DHC Toe, The effects of courtyards on indoor thermal conditions of Chinese shophouse in Malacca, *Procedia Eng.* (2015) <https://doi.org/10.1016/j.proeng.2015.08.1094>.
- [25] D Dan, C Tanasa, V Stoian, S Brata, D Stoian, T Nagy Gyorgy, et al., Passive house design-An efficient solution for residential buildings in Romania, *Energy Sustain. Dev.* (2016) <https://doi.org/10.1016/j.esd.2016.03.007>.
- [26] M Zune, L Rodrigues, M Gillott, Vernacular passive design in Myanmar housing for thermal comfort, *Sustain. Cities Soc.* (2020) <https://doi.org/10.1016/j.scs.2019.101992>.
- [27] WRM Zaki, AH Nawawi, S Sh. Ahmad, Environmental prospective of passive architecture design strategies in terrace houses, *Procedia - Soc. Behav. Sci.* (2012) <https://doi.org/10.1016/j.sbspro.2012.04.194>.
- [28] I Sartori, AG. Hestnes, Energy use in the life cycle of conventional and low-energy buildings: A review article, *Energy Build.* (2007) <https://doi.org/10.1016/j.enbuild.2006.07.001>.
- [29] Y Wang, J Kuckelkorn, FY Zhao, H Spliethoff, W Lang, A state of art of review on interactions between energy performance and indoor environment quality in Passive House buildings, *Renew. Sustain. Energy Rev.* (2017) <https://doi.org/10.1016/j.rser.2016.10.039>.
- [30] Q Roslan, SH Ibrahim, R Affandi, MN Mohd Nawi, A Baharun, A literature review on the improvement strategies of passive design for the roofing system of the modern house in a hot and humid climate region, *Front. Archit. Res.* (2016) <https://doi.org/10.1016/j.foar.2015.10.002>.
- [31] E Solgi, Z Hamedani, R Fernando, H Skates, NE Orji, A literature review of night ventilation strategies in buildings, *Energy Build.* 173 (2018) 337–352 <https://doi.org/10.1016/j.enbuild.2018.05.052>.
- [32] S Peng, J Huang, JE Sheehy, RC Laza, RM Visperas, X Zhong, et al., Rice yields decline with higher night temperature from global warming, *Proc. Natl. Acad. Sci. U. S. A.* (2004) <https://doi.org/10.1073/pnas.0403720101>.



- [33] Aimilios Michael, MP Despina Demosthenous, Natural ventilation for cooling in mediterranean climate: A case study in vernacular architecture of Cyprus, *Energy Build.* (2017).
- [34] B. Givoni, *Climate considerations in building and urban design*, Building (1998).
- [35] N Aste, A Angelotti, M Buzzetti, The influence of the external walls thermal inertia on the energy performance of well insulated buildings, *Energy Build.* (2009) <https://doi.org/10.1016/j.enbuild.2009.06.005>.
- [36] DL Loveday, AH Taki, Outside surface resistance: proposed new value for building design, *Build. Serv. Eng. Res. Technol.* (1998) <https://doi.org/10.1177/014362449801900104>.
- [37] JB Siviour, AE Mould, Thermal bridging: significance in U-value calculation, *Build. Serv. Eng. Res. Technol.* (1988) <https://doi.org/10.1177/014362448800900307>.
- [38] T Kubota, DTH Chyee, S Ahmad, The effects of night ventilation technique on indoor thermal environment for residential buildings in hot-humid climate of Malaysia, *Energy Build.* (2009) <https://doi.org/10.1016/j.enbuild.2009.03.008>.
- [39] AA Jamaludin, H Hussein, AR Mohd Ariffin, N Keumala, A study on different natural ventilation approaches at a residential college building with the internal courtyard arrangement, *Energy Build.* (2014) <https://doi.org/10.1016/j.enbuild.2013.12.050>.
- [40] M Kolokotroni, A. Aronis, Cooling-energy reduction in air-conditioned offices by using night ventilation, *Appl. Energy* (1999) [https://doi.org/10.1016/S0306-2619\(99\)00031-8](https://doi.org/10.1016/S0306-2619(99)00031-8).
- [41] HM. Taleb, Using passive cooling strategies to improve thermal performance and reduce energy consumption of residential buildings in U.A.E. buildings, *Front. Archit. Res.* 3 (2014) 154–165 <https://doi.org/10.1016/j.foar.2014.01.002>.
- [42] *Klimaten to travel, Dubai climate: average weather, temperature, precipitation, best time, Klimaten to Travel* (2018).
- [43] P Blondeau, M Spérando, F Allard, Night ventilation for building cooling in summer, *Sol. Energy* (1997) [https://doi.org/10.1016/S0038-092X\(97\)00076-5](https://doi.org/10.1016/S0038-092X(97)00076-5).
- [44] B. Givoni, Effectiveness of mass and night ventilation in lowering the indoor daytime temperatures. Part I: 1993 experimental periods, *Energy Build.* (1998) [https://doi.org/10.1016/S0378-7788\(97\)00056-X](https://doi.org/10.1016/S0378-7788(97)00056-X).
- [45] DHC Toe, T. Kubota, Comparative assessment of vernacular passive cooling techniques for improving indoor thermal comfort of modern terraced houses in hot-humid climate of Malaysia, *Sol. Energy* (2015) <https://doi.org/10.1016/j.solener.2015.01.035>.
- [46] E Shaviv, A Yezioro, IG Capeluto, Thermal mass and night ventilation as passive cooling design strategy, *Renew. Energy* (2001) [https://doi.org/10.1016/S0960-1481\(01\)00027-1](https://doi.org/10.1016/S0960-1481(01)00027-1).
- [47] J Landsman, G Brager, M Doctor-Pingel, Performance, prediction, optimization, and user behavior of night ventilation, *Energy Build.* (2018) <https://doi.org/10.1016/j.enbuild.2018.01.026>.
- [48] B Chenari, J Dias Carrilho, M Gameiro Da Silva, Towards sustainable, energy-efficient and healthy ventilation strategies in buildings: a review, *Renew. Sustain. Energy Rev.* (2016) <https://doi.org/10.1016/j.rser.2016.01.074>.
- [49] S Omrani, V Garcia-Hansen, B Capra, R Drogemuller, Natural ventilation in multi-storey buildings: design process and review of evaluation tools, *Build. Environ.* (2017) <https://doi.org/10.1016/j.buildenv.2017.02.012>.
- [50] W Liping, WN. Hien, The impacts of ventilation strategies and facade on indoor thermal environment for naturally ventilated residential buildings in Singapore, *Build. Environ.* (2007) <https://doi.org/10.1016/j.buildenv.2006.06.027>.
- [51] M Santamouris, A Sfakianaki, K Pavlou, On the efficiency of night ventilation techniques applied to residential buildings, *Energy Build.* (2010) <https://doi.org/10.1016/j.enbuild.2010.02.024>.
- [52] PC. Agrawal, A review of passive systems for natural heating and cooling of buildings, *Sol. Wind Technol.* (1989) [https://doi.org/10.1016/0741-983X\(89\)90091-X](https://doi.org/10.1016/0741-983X(89)90091-X).
- [53] A Amir, R van Hout, A transient model for optimizing a hybrid nocturnal sky radiation cooling system, *Renew. Energy* (2019) <https://doi.org/10.1016/j.renene.2018.07.114>.
- [54] Y Man, H Yang, Y Qu, Z Fang, A novel nocturnal cooling radiator used for supplemental heat sink of active cooling system, *Procedia Eng.* (2015) <https://doi.org/10.1016/j.proeng.2015.08.1072>.
- [55] B Zhao, M Hu, X Ao, X Huang, X Ren, G Pei, Conventional photovoltaic panel for nocturnal radiative cooling and preliminary performance analysis, *Energy* (2019) <https://doi.org/10.1016/j.energy.2019.03.106>.
- [56] S Zhang, J. Niu, Cooling performance of nocturnal radiative cooling combined with microencapsulated phase change material (MPCM) slurry storage, *Energy Build.* (2012) <https://doi.org/10.1016/j.enbuild.2012.07.041>.
- [57] B Bokor, L Kajtár, D Eryener, Nocturnal radiation: new opportunity in building cooling, *Energy Procedia* (2017) <https://doi.org/10.1016/j.egypro.2017.03.1072>.
- [58] GN Nwaji, CA Okoronkwo, NV Ogueke, EE Anyanwu, Investigation of a hybrid solar collector/nocturnal radiator for water heating/cooling in selected Nigerian cities, *Renew. Energy* (2020) <https://doi.org/10.1016/j.renene.2019.07.144>.
- [59] ZH Wang, Q. Li, Thermodynamic characterisation of urban nocturnal cooling, *Heliyon* (2017) <https://doi.org/10.1016/j.heliyon.2017.e00290>.
- [60] X Lu, P Xu, H Wang, T Yang, J Hou, Cooling potential and applications prospects of passive radiative cooling in buildings: The current state-of-the-art, *Renew. Sustain. Energy Rev.* (2016) <https://doi.org/10.1016/j.rser.2016.07.058>.
- [61] M Hu, B Zhao, X Ao, Y Su, G Pei, Numerical study and experimental validation of a combined diurnal solar heating and nocturnal radiative cooling collector, *Appl. Therm. Eng.* (2018) <https://doi.org/10.1016/j.applthermaleng.2018.08.097>.
- [62] N Khordehgh, Latent thermal energy storage technologies and applications: a review, *Int. J. Thermofluids* 6 (2020) 100039 <https://doi.org/10.1016/j.ijft.2020.100039>.
- [63] RJ Khan, MZH Bhuayan, DH Ahmed, Investigation of heat transfer of a building wall in the presence of phase change material (PCM), *Energy Build. Environ.* 1 (2020) 199–206 <https://doi.org/10.1016/j.enbenv.2020.01.002>.
- [64] PKS Rathore, SK. Shukla, Potential of macroencapsulated PCM for thermal energy storage in buildings: a comprehensive review, *Constr. Build. Mater.* 225 (2019) 723–744 <https://doi.org/10.1016/j.conbuildmat.2019.07.221>.
- [65] S Rucevskis, P Akishin, A Korjakins, Parametric analysis and design optimisation of PCM thermal energy storage system for space cooling of buildings, *Energy Build.* 224 (2020) <https://doi.org/10.1016/j.enbuild.2020.110288>.
- [66] DK Bhamare, MK Rathod, J Banerjee, Numerical model for evaluating thermal performance of residential building roof integrated with inclined phase change material (PCM) layer, *J. Build. Eng.* 28 (2020) 101018 <https://doi.org/10.1016/j.jobe.2019.101018>.
- [67] YP Zhang, KP Lin, R Yang, HF Di, Y Jiang, Preparation, thermal performance and application of shape-stabilized PCM in energy efficient buildings, *Energy Build.* 38 (2006) 1262–1269 <https://doi.org/10.1016/j.enbuild.2006.02.009>.
- [68] M Dardir, L Roccamena, M El Mankibi, F Haghghat, Performance analysis of an improved PCM-to-air heat exchanger for building envelope applications – an experimental study, *Sol. Energy* 199 (2020) 704–720 <https://doi.org/10.1016/j.solener.2020.02.072>.
- [69] H Akeiber, P Nejat, MZA Majid, MA Wahid, F Jomehzadeh, I Zeynali Famileh, et al., A review on phase change material (PCM) for sustainable passive cooling in building envelopes, *Renew. Sustain. Energy Rev.* 60 (2016) 1470–1497 <https://doi.org/10.1016/j.rser.2016.03.036>.
- [70] K Panchabikesan, AAR Vincent, Y Ding, V Ramalingam, Enhancement in free cooling potential through PCM based storage system integrated with direct evaporative cooling (DEC) unit, *Energy* 144 (2018) 443–455 <https://doi.org/10.1016/j.energy.2017.11.117>.
- [71] M Thambidurai, K Panchabikesan, N Krishna Mohan, V Ramalingam, Review on phase change material based free cooling of buildings-The way toward sustainability, *J. Energy Storage* 4 (2015) 74–88 <https://doi.org/10.1016/j.est.2015.09.003>.
- [72] SA Nada, WG Alshaer, RM Saleh, Experimental investigation of PCM transient performance in free cooling of the fresh air of air conditioning systems, *J. Build. Eng.* 29 (2020) 101153 <https://doi.org/10.1016/j.jobe.2019.101153>.
- [73] SA Nada, WG Alshaer, RM Saleh, Thermal characteristics and energy saving of charging/discharging processes of PCM in air free cooling with minimal temperature differences, *Alexandria Eng. J.* 58 (2019) 1175–1190 <https://doi.org/10.1016/j.aej.2019.10.002>.
- [74] K Panchabikesan, MM Joybari, F Haghghat, V Ramalingam, Y Ding, Feasibility study on the year-round operation of PCM based free cooling systems in tropical climatic conditions, *Energy* 192 (2020) 116695 <https://doi.org/10.1016/j.energy.2019.116695>.
- [75] S Huang, W Li, J Lu, Y Li, Experimental study on two type of indirect evaporative cooling heat recovery ventilator, *Procedia Eng.* 205 (2017) 4105–4110 <https://doi.org/10.1016/j.proeng.2017.09.910>.
- [76] M Rampazzo, M Lionello, A Beghi, E Sisti, L Cecchinato, A static moving boundary modelling approach for simulation of indirect evaporative free cooling systems, *Appl. Energy* 250 (2019) 1719–1728 <https://doi.org/10.1016/j.apenergy.2019.04.087>.
- [77] P Xu, X Ma, X Zhao, KS Fancey, Experimental investigation on performance of fabrics for indirect evaporative cooling applications, *Build. Environ.* 110 (2016) 104–114 <https://doi.org/10.1016/j.buildenv.2016.10.003>.
- [78] B Zheng, C Guo, Q Shi, J Lv, Y You, An analytical model for cross-flow indirect evaporative cooling considering condensation under various fresh air conditions, *Energy Procedia* 158 (2019) 5747–5752 <https://doi.org/10.1016/j.egypro.2019.01.557>.
- [79] Q Chen, M Burhan, MW Shahzad, D Ybyraiymkul, FH Akhtar, KC Ng, Simultaneous production of cooling and freshwater by an integrated indirect evaporative cooling and humidification-dehumidification desalination cycle, *Energy Convers. Manag.* 221 (2020) 113169 <https://doi.org/10.1016/j.enconman.2020.113169>.
- [80] Y Al Horr, B Tashstoush, N Chilengwe, M Musthafa, Operational mode optimization of indirect evaporative cooling in hot climates, *Case Stud. Therm. Eng.* 18 (2020) 100574 <https://doi.org/10.1016/j.csite.2019.100574>.
- [81] I Ahmad, N Khordehgh, J Malinauskaitė, H Jouhara, Recent advances and applications of solar photovoltaics and thermal technologies, *Energy* (2020) <https://doi.org/10.1016/j.energy.2020.118254>.
- [82] N Khordehgh, V Guichet, SP Lester, H Jouhara, Computational study and experimental validation of a solar photovoltaics and thermal technology, *Renew. Energy* (2019) <https://doi.org/10.1016/j.renene.2019.05.108>.
- [83] B Yu, X Liu, N Li, SS Liu, J Ji, The performance analysis of a purified PV/T-Trombe wall based on thermal catalytic oxidation process in winter, *Energy Convers. Manag.* (2020) <https://doi.org/10.1016/j.enconman.2019.112262>.
- [84] NAS Elminshawy, M El Ghandour, HM Gad, DG El-Damhogi, K El-Nahas, MF Addas, The performance of a buried heat exchanger system for PV panel cooling under elevated air temperatures, *Geothermics* (2019) <https://doi.org/10.1016/j.geothermics.2019.05.012>.
- [85] AE Kabeel, M Abdelgaied, R Sathyamurthy, A comprehensive investigation of the optimization cooling technique for improving the performance of PV module with reflectors under Egyptian conditions, *Sol. Energy* (2019) <https://doi.org/10.1016/j.solener.2019.05.019>.
- [86] S Nizetić, D Čoko, A Yadav, F Grubišić-Čabo, Water spray cooling technique applied on a photovoltaic panel: The performance response, *Energy Convers. Manag.* (2016) <https://doi.org/10.1016/j.enconman.2015.10.079>.
- [87] A Hasan, SJ McCormack, MJ Huang, J Sarwar, B Norton, Increased photovoltaic performance through temperature regulation by phase change materials: Materials comparison in different climates, *Sol. Energy* (2015) <https://doi.org/10.1016/j.solener.2015.02.003>.

- [88] J Zhou, X Zhao, Y Yuan, J Li, M Yu, Y Fan, Operational performance of a novel heat pump coupled with mini-channel PV/T and thermal panel in low solar radiation, *Energy Built. Environ.* (2020) <https://doi.org/10.1016/j.enbenv.2019.08.001>.
- [89] R Lazzarin, M. Noro, Photovoltaic/Thermal (PV/T)/ground dual source heat pump: optimum energy and economic sizing based on performance analysis, *Energy Build.* (2020) <https://doi.org/10.1016/j.enbuild.2020.109800>.
- [90] M Yu, F Chen, S Zheng, J Zhou, X Zhao, Z Wang, et al., Experimental investigation of a novel solar micro-channel loop-heat-pipe photovoltaic/thermal (MC-LHP-PV/T) system for heat and power generation, *Appl. Energy* (2019) <https://doi.org/10.1016/j.apenergy.2019.113929>.
- [91] V Guichet, N Khordehgah, H Jouhara, Experimental investigation and analytical prediction of a multi-channel flat heat pipe thermal performance, *Int. J. Thermofluids* (2020) <https://doi.org/10.1016/j.ijft.2020.100038>.
- [92] N Khordehgah, A. Żabnieńska-Góra, H. Jouhara, Energy performance analysis of a PV/T system coupled with domestic hot water system, *Chem. Eng.* 4 (2020) 22.
- [93] H Jouhara, J Milko, J Danielewicz, MA Sayegh, M Szulgowska-Zgrzywa, JB Ramos, et al., The performance of a novel flat heat pipe based thermal and PV/T (photovoltaic and thermal systems) solar collector that can be used as an energy-active building envelope material, *Energy* (2016) <https://doi.org/10.1016/j.energy.2015.07.063>.
- [94] H Jouhara, M Szulgowska-Zgrzywa, MA Sayegh, J Milko, J Danielewicz, TK Nannou, et al., The performance of a heat pipe based solar PV/T roof collector and its potential contribution in district heating applications, *Energy* (2017) <https://doi.org/10.1016/j.energy.2016.04.070>.