

Design of Broadband Microstrip Quasi-Yagi Antenna with double branch structure

Yuchao Feng

Department of Electronic and Electrical Engineering
Brunel University London
Kingston Lane, Uxbridge
Middlesex, UK
yuchao.feng@brunel.ac.uk

Haoming Xiang

Department of Electronic and Electrical Engineering
Brunel University London
Kingston Lane, Uxbridge
Middlesex, UK
Haoming.xiang@brunel.ac.uk

Shaoqing Hu

Department of Electronic and Electrical Engineering
Brunel University London
Kingston Lane, Uxbridge
Middlesex, UK
Shaoqing.hu@brunel.ac.uk

Rajagopal Nilavalan

Department of Electronic and Electrical Engineering
Brunel University London
Kingston Lane, Uxbridge
Middlesex, UK
Rajagopal.Nilavalan@brunel.ac.uk

Abstract—In this paper, a Broadband quasi-Yagi antenna is proposed for sub-6G and WLAN applications. It consists of a quasi-Yagi antenna with a double branch structure. Simulation results indicate that the antenna exhibits an impedance bandwidth ranging from 2.35 GHz to 4.47 GHz (61.9%) and a peak gain of 3.23 dBi at 4.3 GHz.

Keywords—quasi-yagi antenna, broadband antenna, sub-6G, WLAN

I. INTRODUCTION

In recent years, the rapid advancements in WLAN and sub-6G technology have created a significant demand for broadband or multi-frequency antennas with superior performance. Among these, the microstrip quasi-Yagi antenna has garnered considerable attention due to its notable advantages, including high gain, a simple structure, and easy integration. However, it is important to address one of its limitations, which is its narrow bandwidth.

To overcome this challenge, researchers have explored various approaches to broaden the antenna's bandwidth. Some have focused on modifying the antenna's deficit structure, such as incorporating a broadband balun to enhance the antenna's bandwidth [1]. Others have investigated changes in the driver and reflector structure to expand the antenna's bandwidth [2]. Additionally, the inclusion of new branches to enable the antenna to operate at multiple frequencies has also been explored [3]. These innovative techniques aim to overcome the narrow bandwidth drawback and enhance the overall performance of the microstrip quasi-Yagi antenna.

In this paper, a microstrip quasi-Yagi antenna is presented. The antenna employs two pairs of dipole antennas with a CPW feed structure to enable dual-frequency operation, thereby expanding the antenna's bandwidth.

II. DESIGN OF ANTENNA

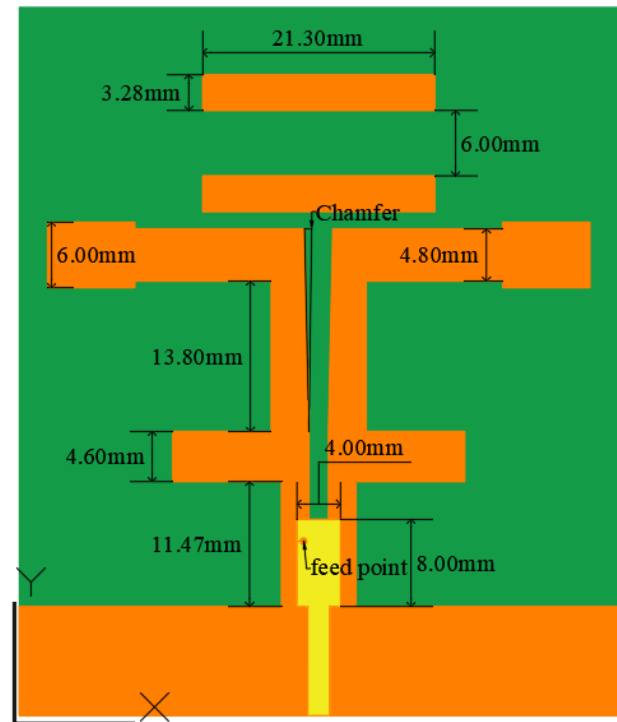

Figure 1. Layout of the proposed antenna

The quasi-Yagi antenna structure is illustrated in Figure 1. The antenna is fabricated on an FR4 substrate measuring $65\text{mm} \times 55\text{mm} \times 1.15\text{mm}$. Rectangular reflectors are positioned at the bottom of the antenna to enhance radiation performance. The driver section of the antenna utilizes two pairs of dipoles with different lengths and widths to achieve multi-frequency resonance. Chamfer is used on the part connecting the two pairs of drivers, improving impedance matching in the required frequency band. Two directors above the dipoles are used to enhance radiation performance and increase gain. The integrated balun was used to match the input impedance.

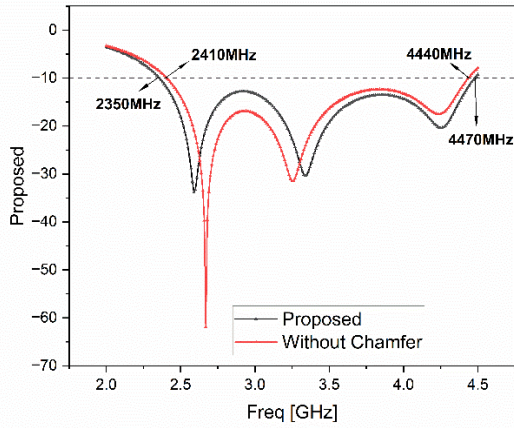
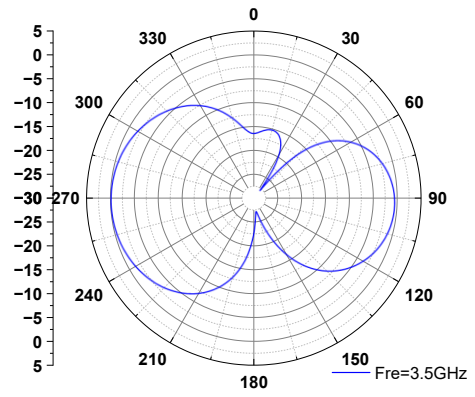
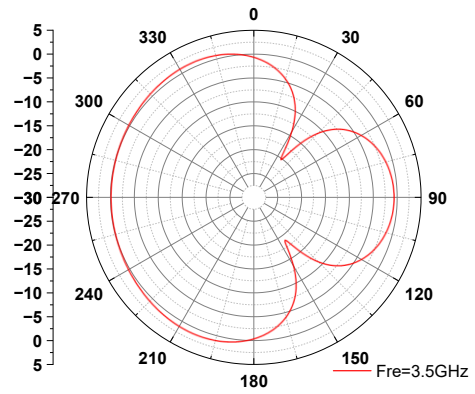

Figure 2. Simulated reflection coefficient

Figure 2 depicts the reflection coefficients exhibited by the antenna, both with and without the Chamfer. When the antenna is not chamfered, its operational frequency spans from 2410MHz to 4440MHz, rendering it incompatible with WLAN applications (2400MHz to 2484MHz). However, by incorporating chamfering into the antenna design, the enhanced impedance matching extends the bandwidth to encompass the range of 2350MHz to 4470MHz.



(c)



(d)

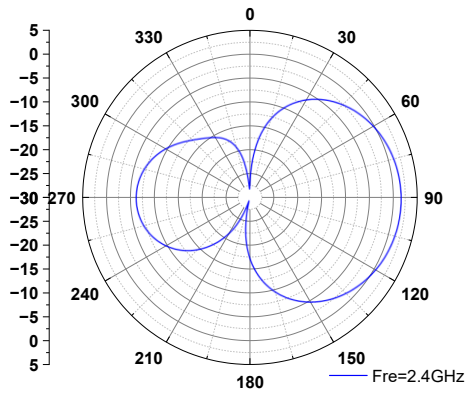

(a)

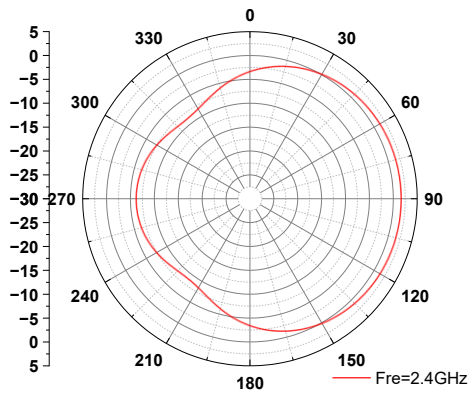

(b)

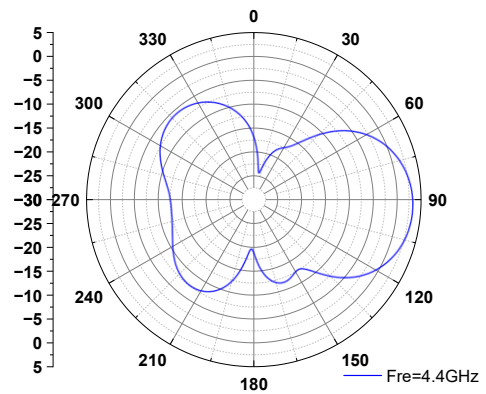

(e)

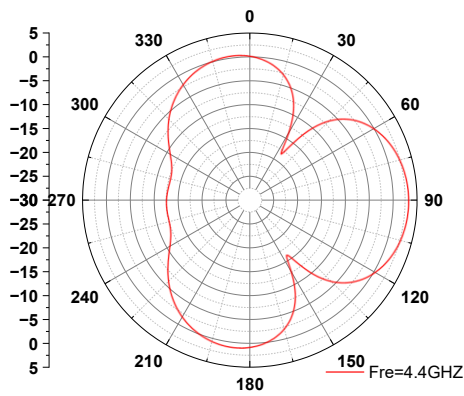

(f)

Figure 3. Radiation patterns of the proposed antenna. (a)XOY (b)YOZ (c)XOY (d)YOZ (e)XOY (f)YOZ

Figure 3 showcases the simulated radiation patterns of the proposed antenna in the XOY plane and YOZ plane at 2.4 GHz, 3.5 GHz and 4.4GHz. The results indicate that the antenna exhibits a consistently high and stable endfire pattern. Furthermore, the antenna achieves a maximum gain of 3.23 dBi.

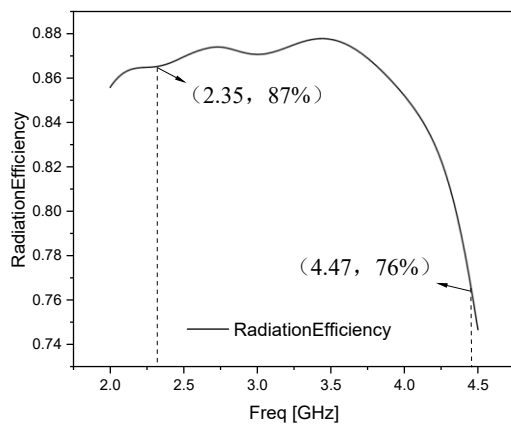

Figure 4. Simulated radiation efficiency

Figure 4 showcases the radiation efficiency of the proposed antenna, in the operating frequency range, the radiation efficiency remains consistently above 76%.

III. CONCLUSION

This paper presents a broadband quasi-Yagi antenna structure with two branches. Stable radiation performance and reflection coefficient were attained through simulation. The proposed antenna exhibits suitability for WLAN (2.4 -2.484 GHz), n77(3.3 GHz-4.2 GHz) and n78(3.3 GHz-3.8 GHz) applications.

REFERENCES

- [1] X. Peng, W. Guangming, and L. Haipeng, 'A novel design of broadband Quasi-Yagi antenna loaded with split-ring resonators', in *2016 IEEE International Conference on Ubiquitous Wireless Broadband (ICUWB)*, Oct. 2016, pp. 1–4. doi: 10.1109/ICUWB.2016.7790476.
- [2] R. Ullah, S. Ullah, B. Kamal, and R. Ullah, 'A Four-Port Multiple Input Multiple Output (MIMO) Antenna for Future 5G Smartphone Applications', in *2019 International Conference on Electrical, Communication, and Computer Engineering (ICECCE)*, Jul. 2019, pp. 1–5. doi: 10.1109/ICECCE47252.2019.8940779.
- [3] Y. Zhang and S. Wu, 'A Wideband Quasi-Yagi Antenna Using Four-Step Slotline with Metasurface for Sub-6G Applications', in *2021 IEEE 4th International Conference on Electronic Information and Communication Technology (ICEICT)*, Aug. 2021, pp. 156–158. doi: 10.1109/ICEICT53123.2021.9531246.